

TM 55-1945-205-24-1-2

TECHNICAL MANUAL

UNIT, DIRECT SUPPORT AND GENERAL SUPPORT
MAINTENANCE MANUAL

FOR

**MODULAR CAUSEWAY SYSTEM (MCS)
CAUSEWAY FERRY (CF) ENGINE
8V92TA
NSN PENDING**

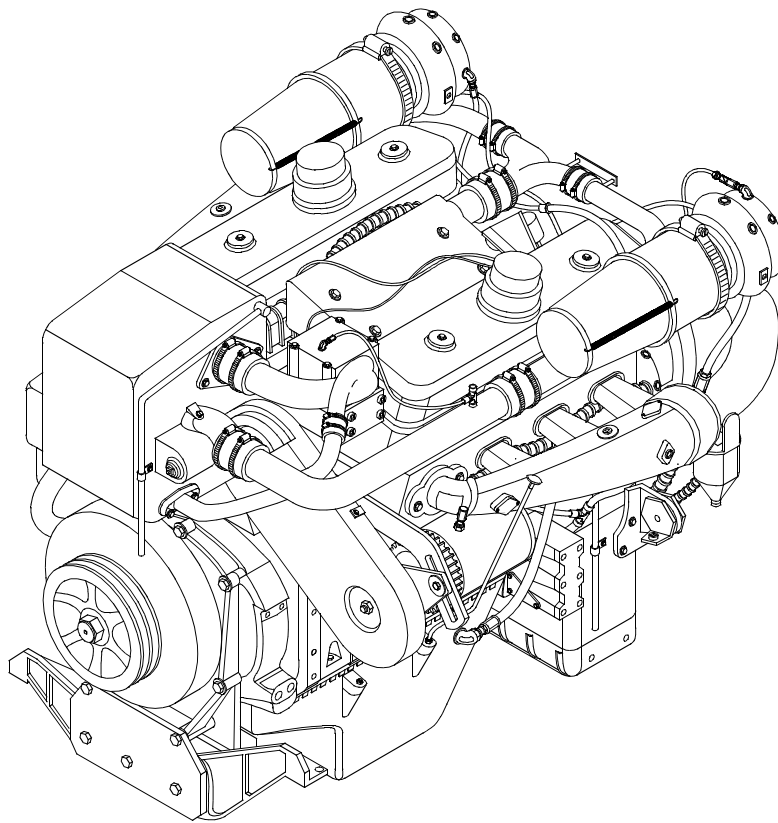

This manual supersedes TM 55-1945-205-24-2 dated 29 August 1997 including all changes.

DISTRIBUTION STATEMENT A - Approved for public release, distribution is unlimited.

**HEADQUARTERS, DEPARTMENT OF THE ARMY
OCTOBER 2003**

WARNING SUMMARY

NO SMOKING

Smoking is prohibited aboard this vessel.

JEWELRY

Remove rings, bracelets, wristwatches, and neck chains before working around or on a unit.

HEAVY OBJECTS

Handling heavily weighted objects can cause bodily injury. Do not lift materials or equipment over 50 lb without using appropriate material handling equipment.

BATTERIES

Do not smoke around batteries. Personnel must wear goggles and chemical resistant gloves when adding electrolyte and cleaning up spills.

HAZARD REPORTING

Report all hazards. It is your responsibility to report hazards through your chain-of-command.

HIGH VOLTAGE

Use extreme caution when checking energized circuits. Always place power off warning tags on power supply switches so that no one will apply power while performing maintenance.

HAZARDOUS FUMES IN CONFINED SPACES

The lazaret, engine, fuel and storage compartments are confined spaces and may contain hazardous fumes. Refer to FM 55-502 before entering a confined space. Never enter a confined space before checking the confined space with a gas free meter. Operate the exhaust plenum ventilation fan to remove fumes.

TORQUE VALUES

For torque not specified in an individual work package, refer to the Torque Limits Work Package located in the General Maintenance Section of this manual. Failure to tighten fasteners to specified torque may result in damage to equipment and death or injury to personnel.

NUCLEAR, BIOLOGICAL OR CHEMICAL

In the event equipment has been exposed to Nuclear, Biological or Chemical warfare, the equipment shall be handled with extreme caution and decontaminated in accordance with FM 3-5, instructions for Immediate, Operational and Through decon procedures adapted for the marine environment. Unprotected personnel can experience injury or death if residual toxic agents or radioactive material are present. If equipment is exposed to radioactive, biological or chemical agents, personnel must wear protective mask, hood, protective overgarments, chemical gloves and chemical boots in accordance with MOPP - level prescribed by the OIC or NCOIC.

FUELS

Personnel must wear chemical resistant gloves when handling fuels. Promptly wash exposed skin and change fuel-soaked clothing.

COOLANTS

Before opening coolant system, allow time to cool and wear effective hand, eye and skin protection.

ICE BUILDUP

Cold weather operations could create ice buildup on exposed surfaces producing hazardous footing conditions. Use extreme care when operating under icing conditions; death or serious injury to personnel could occur.

SAFETY WARNING ICONS



EAR PROTECTION

EAR PROTECTION - Headphones over ears shows that noise level will harm ears.



ELECTRICAL

ELECTRICAL - Electrical wire to hand with electricity symbol running through hand shows that shock hazard is present.



EYE PROTECTION

EYE PROTECTION - Person with goggles shows that the material will injure the eyes.

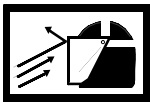

FLYING PARTICLES

FLYING PARTICLES 2 - Arrows bouncing off face with face shield shows that particles flying through the air will harm face.



HEAVY OBJECTS

HEAVY OBJECTS - Human figure stooping over heavy object shows physical injury potential from improper lifting technique.



HEAVY PARTS

HEAVY PARTS - Foot with heavy object on top shows that heavy parts can crush and harm.



HEAVY PARTS

HEAVY PARTS 3 - Heavy object on human figure shows that heavy parts present a danger to life or limb.

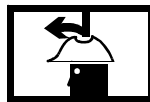

HELMET PROTECTION

HELMET - Arrow bouncing off head with helmet shows that falling parts present a danger.



HOT AREA

HOT AREA - Hand over object radiating heat shows that part is hot and can burn.

SAFETY WARNING ICONS - CONTINUED

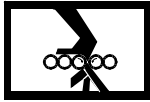

MOVING PARTS

MOVING PARTS - Hand with fingers caught between rollers shows that the moving parts of the equipment present a danger to life or limb.



MOVING PARTS

MOVING PARTS 2 - Hand with fingers caught between gears shows that the moving parts of the equipment present a danger to life or limb.



SLICK FLOOR

SLICK FLOOR - Wavy line on floor with legs prone shows that slick floor presents a danger for falling.

HAZARDOUS MATERIAL WARNING ICONS

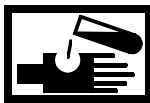

CHEMICAL

CHEMICALS - Drops of liquid on hand shows that the material will cause burns or irritation to human skin or tissue.



EXPLOSION

EXPLOSION - Rapidly expanding symbol shows that the material may explode if subjected to high temperatures, sources of ignition or high pressure.



FIRE

FIRE - Flame shows that a material may ignite and cause burns.



POISON

POISON - Skull and crossbones shows that a material is poisonous or is a danger to life.



VAPOR

VAPOR - Human figure in a cloud shows that material vapors present a danger to life or health.

LIST OF EFFECTIVE PAGES / WORK PACKAGES

Dates of issue for original and changed pages / work packages are:

Original 1 October 2003

TOTAL NUMBER OF PAGES FOR FRONT AND REAR MATTER IS 54 AND TOTAL NUMBER OF WORK PACKAGES IS 188 CONSISTING OF THE FOLLOWING:

Page / WP No.	*Change No.	Page / WP No.	*Change No.
Title	0	WP 0037 00 (2 pgs)	0
Warning	0	WP 0038 00 (6 pgs)	0
List	0	WP 0039 00 (2 pgs)	0
i-iii	0	WP 0040 00 (6 pgs)	0
Chp 1 title page	0	WP 0041 00 (2 pgs)	0
WP 0001 00 (4 pgs)	0	WP 0042 00 (40 pgs)	0
WP 0002 00 (2 pgs)	0	WP 0043 00 (4 pgs)	0
WP 0003 00 (6 pgs)	0	WP 0044 00 (4 pgs)	0
WP 0004 00 (2 pgs)	0	WP 0045 00 (4 pgs)	0
WP 0005 00 (18 pgs)	0	WP 0046 00 (8 pgs)	0
Chp 2 title page	0	WP 0047 00 (4 pgs)	0
WP 0006 00 (2 pgs)	0	WP 0048 00 (6 pgs)	0
WP 0007 00 (4 pgs)	0	WP 0049 00 (4 pgs)	0
WP 0008 00 (4 pgs)	0	WP 0050 00 (4 pgs)	0
WP 0009 00 (2 pgs)	0	WP 0051 00 (10 pgs)	0
WP 0010 00 (4 pgs)	0	WP 0052 00 (4 pgs)	0
WP 0011 00 (2 pgs)	0	WP 0053 00 (2 pgs)	0
WP 0012 00 (4 pgs)	0	WP 0054 00 (4 pgs)	0
WP 0013 00 (4 pgs)	0	WP 0055 00 (4 pgs)	0
WP 0014 00 (4 pgs)	0	WP 0056 00 (6 pgs)	0
WP 0015 00 (4 pgs)	0	WP 0057 00 (2 pgs)	0
WP 0016 00 (4 pgs)	0	WP 0058 00 (6 pgs)	0
WP 0017 00 (2 pgs)	0	WP 0059 00 (4 pgs)	0
WP 0018 00 (2 pgs)	0	WP 0060 00 (14 pgs)	0
WP 0019 00 (4 pgs)	0	WP 0061 00 (4 pgs)	0
WP 0020 00 (2 pgs)	0	WP 0062 00 (16 pgs)	0
WP 0021 00 (2 pgs)	0	WP 0063 00 (4 pgs)	0
WP 0022 00 (2 pgs)	0	WP 0064 00 (6 pgs)	0
WP 0023 00 (4 pgs)	0	WP 0065 00 (2 pgs)	0
WP 0024 00 (2 pgs)	0	WP 0066 00 (4 pgs)	0
Chp 3 title page	0	WP 0067 00 (4 pgs)	0
WP 0025 00 (2 pgs)	0	WP 0068 00 (8 pgs)	0
WP 0026 00 (4 pgs)	0	WP 0069 00 (4 pgs)	0
WP 0027 00 (4 pgs)	0	WP 0070 00 (4 pgs)	0
WP 0028 00 (2 pgs)	0	WP 0071 00 (20 pgs)	0
WP 0029 00 (2 pgs)	0	WP 0072 00 (8 pgs)	0
WP 0030 00 (4 pgs)	0	WP 0073 00 (16 pgs)	0
WP 0031 00 (18 pgs)	0	WP 0074 00 (4 pgs)	0
WP 0032 00 (2 pgs)	0	WP 0075 00 (4 pgs)	0
WP 0033 00 (4 pgs)	0	WP 0076 00 (4 pgs)	0
WP 0034 00 (4 pgs)	0	WP 0077 00 (4 pgs)	0
WP 0035 00 (4 pgs)	0	WP 0078 00 (10 pgs)	0
WP 0036 00 (4 pgs)	0	WP 0079 00 (4 pgs)	0

Page / WP No.	*Change No.	Page / WP No.	*Change No.
WP 0080 00 (4 pgs)	0	WP 0132 00 (4 pgs)	0
WP 0081 00 (6 pgs)	0	WP 0133 00 (4 pgs)	0
WP 0082 00 (2 pgs)	0	WP 0134 00 (10 pgs)	0
WP 0083 00 (6 pgs)	0	WP 0135 00 (2 pgs)	0
WP 0084 00 (2 pgs)	0	WP 0136 00 (2 pgs)	0
WP 0085 00 (6 pgs)	0	WP 0137 00 (4 pgs)	0
WP 0086 00 (2 pgs)	0	WP 0138 00 (8 pgs)	0
WP 0087 00 (4 pgs)	0	WP 0139 00 (2 pgs)	0
WP 0088 00 (4 pgs)	0	WP 0140 00 (2 pgs)	0
WP 0089 00 (2 pgs)	0	WP 0141 00 (4 pgs)	0
WP 0090 00 (4 pgs)	0	WP 0142 00 (4 pgs)	0
WP 0091 00 (6 pgs)	0	WP 0143 00 (8 pgs)	0
WP 0092 00 (4 pgs)	0	WP 0144 00 (4 pgs)	0
WP 0093 00 (10 pgs)	0	WP 0145 00 (4 pgs)	0
WP 0094 00 (4 pgs)	0	WP 0146 00 (2 pgs)	0
WP 0095 00 (12 pgs)	0	WP 0147 00 (4 pgs)	0
WP 0096 00 (4 pgs)	0	WP 0148 00 (2 pgs)	0
WP 0097 00 (2 pgs)	0	WP 0149 00 (4 pgs)	0
WP 0098 00 (4 pgs)	0	WP 0150 00 (4 pgs)	0
WP 0099 00 (6 pgs)	0	WP 0151 00 (4 pgs)	0
WP 0100 00 (2 pgs)	0	WP 0152 00 (4 pgs)	0
WP 0101 00 (4 pgs)	0	WP 0153 00 (4 pgs)	0
WP 0102 00 (4 pgs)	0	WP 0154 00 (10 pgs)	0
WP 0103 00 (6 pgs)	0	WP 0155 00 (4 pgs)	0
WP 0104 00 (2 pgs)	0	WP 0156 00 (2 pgs)	0
WP 0105 00 (4 pgs)	0	WP 0157 00 (2 pgs)	0
WP 0106 00 (2 pgs)	0	WP 0158 00 (2 pgs)	0
WP 0107 00 (4 pgs)	0	WP 0159 00 (2 pgs)	0
WP 0108 00 (2 pgs)	0	WP 0160 00 (4 pgs)	0
WP 0109 00 (6 pgs)	0	WP 0161 00 (6 pgs)	0
WP 0110 00 (6 pgs)	0	WP 0162 00 (2 pgs)	0
WP 0111 00 (18 pgs)	0	WP 0163 00 (4 pgs)	0
WP 0112 00 (4 pgs)	0	WP 0164 00 (2 pgs)	0
WP 0113 00 (4 pgs)	0	WP 0165 00 (2 pgs)	0
WP 0114 00 (8 pgs)	0	WP 0166 00 (2 pgs)	0
WP 0115 00 (4 pgs)	0	WP 0167 00 (2 pgs)	0
WP 0116 00 (2 pgs)	0	WP 0168 00 (2 pgs)	0
WP 0117 00 (4 pgs)	0	WP 0169 00 (2 pgs)	0
WP 0118 00 (2 pgs)	0	WP 0170 00 (2 pgs)	0
WP 0119 00 (6 pgs)	0	WP 0171 00 (4 pgs)	0
WP 0120 00 (6 pgs)	0	WP 0172 00 (2 pgs)	0
WP 0121 00 (4 pgs)	0	WP 0173 00 (2 pgs)	0
WP 0122 00 (4 pgs)	0	WP 0174 00 (2 pgs)	0
WP 0123 00 (2 pgs)	0	WP 0175 00 (6 pgs)	0
WP 0124 00 (4 pgs)	0	WP 0176 00 (4 pgs)	0
WP 0125 00 (2 pgs)	0	WP 0177 00 (2 pgs)	0
WP 0126 00 (4 pgs)	0	WP 0178 00 (2 pgs)	0
WP 0127 00 (6 pgs)	0	WP 0179 00 (4 pgs)	0
WP 0128 00 (10 pgs)	0	WP 0180 00 (8 pgs)	0
WP 0129 00 (4 pgs)	0	WP 0181 00 (2 pgs)	0
WP 0130 00 (2 pgs)	0	WP 0182 00 (6 pgs)	0
WP 0131 00 (2 pgs)	0	WP 0183 00 (132 pgs)	0

Page / WP No.	*Change No.
Chp 4 title page	0
WP 0184 00 (2 pgs)	0
WP 0185 00 (4 pgs)	0
WP 0186 00 (74 pgs)	0
WP 0187 00 (4 pgs)	0
WP 0188 00 (8 pgs)	0

* Zero in this column indicates an original page.

TECHNICAL MANUAL

**UNIT, DIRECT SUPPORT AND GENERAL SUPPORT MAINTENANCE MANUAL
FOR**

**MODULAR CAUSEWAY SYSTEM (MCS)
CAUSEWAY FERRY (CF) ENGINE
8V92TA
NSN PENDING**

This manual supersedes TM 55-1945-205-24-2 dated 29 August 1997 including all changes.

REPORTING ERRORS AND RECOMMENDING IMPROVEMENTS

You can help improve this publication. If you find any mistakes or if you know of a way to improve the procedures, please let us know. Submit your DA Form 2028-2 (Recommended Changes to Equipment Technical Publications), through the Internet, on the Army Electronic Product Support (AEPS) website. The Internet address is <http://aeprs.ria.army.mil>. If you need a password, scroll down and click on "ACCESS REQUEST FORM". The DA Form 2028 is located in the ONLINE FORMS PROCESSING section of the AEPS website. Fill out the form and click on "SUBMIT". Using this form on the AEPS website will enable us to respond quicker to your comments and better manage the DA Form 2028 program. You may also mail, E-mail or fax your letter, DA Form 2028, or DA Form 2028-2 directly to: Commander, U.S. Army Tank-Automotive and Armaments Command, ATTN: AMSTA-LC-CIP-WT, Rock Island, IL 61299-7630. The E-mail address is TACOM-TECH-PUBS@ria.army.mil. The fax number is DSN 793-0726 or Commercial (309) 782-0726.

TABLE OF CONTENTS

WP Sequence No.

WARNING SUMMARY

HOW TO USE THIS MANUAL

CHAPTER 1 - DESCRIPTION AND THEORY OF OPERATION

General Information	0001 00
Description and Data, Equipment Characteristics, Capabilities and Features	0002 00
Description and Data, Location and Description of Major Components	0003 00
Description and Data, Equipment Data	0004 00
Theory of Operation	0005 00

CHAPTER 2 - UNIT, DIRECT SUPPORT AND GENERAL SUPPORT TROUBLESHOOTING PROCEDURES

Troubleshooting Procedures Index	0006 00
Engine Will Not Turn Over	0007 00
Engine Turns Over But Will Not Start	0008 00
Engine Does Not Start In Cold Temperatures	0009 00
Engine Starts With Difficulty and Run Rough	0010 00
Sudden Loss of Power	0011 00
Engine Lacks Power	0012 00
Not Receiving Fuel From Tank	0013 00
High Oil Consumption	0014 00
Low Reading On Oil Pressure Gage	0015 00
Excessive Reading On Oil Pressure Gage	0016 00
Above Normal Reading On Engine Coolant Temperature Gage	0017 00
Below Normal Reading On Engine Coolant Temperature Gage	0018 00
Engine Fails To Stop When Emergency Stop Is Activated	0019 00
Noisy Operation or Vibration In Turbocharger	0020 00
Electrical Generating System Shows Low Battery and Low or No Charging Rate	0021 00
Electrical Generating System Shows Fully Charged Battery and High Charging Rate	0022 00
Electronic Governor Actuator Stays At Minimum Position When Power Is Applied	0023 00
Electronic Governor Goes To Full Stroke When DC Power Is Applied and Engine Is Not Operating	0024 00

CHAPTER 3 - UNIT, DIRECT SUPPORT AND GENERAL SUPPORT MAINTENANCE INSTRUCTIONS

Service Upon Receipt	0025 00
Preventive Maintenance Checks and Services (PMCS) Procedures Introduction	0026 00
Preventive Maintenance Checks and Services (PMCS) and Lubrication Procedures	0027 00
Tune-Up	0028 00
Mounts, Inspection	0029 00
Testing	0030 00
Removal and Installation	0031 00
Maintenance Stand, Installation and Removal	0032 00
Alignment	0033 00
Air Box, Testing	0034 00
Air Box Covers, Removal and Installation	0035 00
Air Box Drains, Removal, Cleaning, Inspection and Installation	0036 00

TABLE OF CONTENTS (CONT'D)

WP Sequence No.

CHAPTER 3 - UNIT, DIRECT SUPPORT AND GENERAL SUPPORT MAINTENANCE

INSTRUCTIONS (CONT'D)

Air Box Drain Hose, Replacement	0037 00
Rear Cylinder Block Plate, Removal and Installation	0038 00
Rear Cylinder Block Plate, Repair	0039 00
Front Cylinder Block Plate, Removal and Installation	0040 00
Front Cylinder Block Plate, Repair	0041 00
Engine Block, Repair	0042 00
Cylinder Head Poppet Valve Rocker Arm Covers, Replacement	0043 00
Cylinder Head Crankcase Breather, Cleaning	0044 00
Cylinder Head Exhaust Valves, Adjustment	0045 00
Cylinder Head, Removal and Installation	0046 00
Rear Lifting Brackets, Replacement	0047 00
Cylinder Head Poppet Valve Rocker Arm, Removal, Cleaning, Inspection and Installation	0048 00
Cylinder Head Poppet Valve Rocker Arm, Repair	0049 00
Cylinder Head Fuel Manifold, Removal, Cleaning, Inspection and Installation	0050 00
Cylinder Head, Repair	0051 00
Cylinder Head Cam Follower, Replacement	0052 00
Cylinder Head Push Rod, Replacement	0053 00
Cylinder Head Exhaust Valve, Removal and Installation	0054 00
Cylinder Head Exhaust Valve, Repair	0055 00
Cylinder Head Exhaust Valve Seat Inserts, Replacement	0056 00
Cylinder Head Valve Guide Bridge, Replacement	0057 00
Cylinder Head Valve Guides and Seals, Replacement	0058 00
Cylinder Head Exhaust Valve Guides, Cleaning and Inspection	0059 00
Crankshaft and Stabilizer, Removal, Cleaning, Inspection, Repair and Installation	0060 00
Crankshaft Rear Oil Seal, Replacement	0061 00
Camshaft and Bearings, Replacement	0062 00
Camshaft Vibration Damper, Replacement	0063 00
Camshaft Gears, Replacement	0064 00
Camshaft Balance Weight, Replacement	0065 00
Camshaft Accessory Drive Pulley, Replacement	0066 00
Camshaft Idler Gears, Removal and Installation	0067 00
Camshaft Idler Gear, Repair	0068 00
Flywheel, Removal and Installation	0069 00
Flywheel, Repair	0070 00
Flywheel Housing, Replacement	0071 00
Piston and Liner Assembly, Removal and Replacement	0072 00
Piston and Cylinder Liner, Rebuild	0073 00
Vibration Damper, Replacement	0074 00
Front Balance Weight Cover, Repair	0075 00
Front Balance Weight Cover, Removal and Installation	0076 00
Fuel System, Priming	0077 00
Fuel System, Testing	0078 00
Fuel Filter Cartridge, Replacement	0079 00
Fuel Hoses and Tubes, Replacement	0080 00
Fuel Cooler, Replacement	0081 00

TABLE OF CONTENTS (CONT'D)

WP Sequence No.

CHAPTER 3 - UNIT, DIRECT SUPPORT AND GENERAL SUPPORT MAINTENANCE

INSTRUCTIONS (CONT'D)

Fuel Cooler Mounting Bracket, Replacement	0082 00
Fuel Filter Adaptor, Replacement	0083 00
Fuel Filter Mounting Bracket, Replacement	0084 00
Fuel Adaptor (Block), Replacement	0085 00
Fuel Injector Control Tube and Lever Assembly, Removal and Installation	0086 00
Fuel Injector Control Tube and Lever Assembly, Repair	0087 00
Fuel Ignition Modulator Assembly, Removal and Installation	0088 00
Fuel Ignition Modulator Assembly, Repair	0089 00
Fuel Ignition Modulator Assembly, Adjustment	0090 00
Fuel Injector Assembly, Removal, Cleaning, Inspection and Installation	0091 00
Fuel Injector Timing, Adjustment	0092 00
Fuel Injector Rack Control Lever, Adjustment	0093 00
Fuel Pump, Removal and Installation	0094 00
Fuel Pump, Repair	0095 00
Fuel Priming Pump, Replacement	0096 00
Electronic Governor Rod Assembly, Replacement	0097 00
Electronic Governor Actuator, Replacement	0098 00
Electronic Governor Controller, Replacement and Adjustment	0099 00
Electronic Governor Magnetic Pick-Up, Replacement	0100 00
Electronic Governor Drive Assembly, Removal and Installation	0101 00
Electronic Governor Drive Assembly, Repair	0102 00
Air Intake Housing, Removal, Cleaning, Inspection, Repair and Installation	0103 00
Air Inlet Collector Assembly, Removal and Installation	0104 00
Air Inlet Collector Assembly, Repair	0105 00
Crankcase Breather Limiter Assembly, Replacement	0106 00
Crankcase Ventilation Breather Pipe, Replacement	0107 00
Blower Bypass Valve, Replacement	0108 00
Blower Drive Shaft and Spring Assembly, Replacement	0109 00
Blower, Removal and Installation	0110 00
Blower Assembly, Repair	0111 00
Blower Drive Assembly, Removal and Installation	0112 00
Blower Drive Assembly, Repair	0113 00
Turbocharger, Replacement	0114 00
Lube Oil System Crankcase, Servicing	0115 00
Lube Oil System Crankcase, Pressure Testing	0116 00
Lube Oil System Turbocharger Flanged Oil Tube To Engine Oil Hose, Replacement	0117 00
Lube Oil System Hoses, Replacement	0118 00
Lube Oil Pump, Removal and Installation	0119 00
Lube Oil Pump, Repair	0120 00
Lube Oil Pump, Inlet Screen, Removal, Cleaning, Inspection and Installation	0121 00
Lube Oil System Distribution Components, Removal, Cleaning, Inspection and Installation	0122 00
Lube Oil Pressure Regulator Valve, Removal and Installation	0123 00
Lube Oil Pressure Regulator Valve, Repair	0124 00
Lube Oil Pressure Relief Valve, Removal and Installation	0125 00
Lube Oil Pressure Relief Valve, Repair	0126 00
Lube Oil Pan, Replacement	0127 00

TABLE OF CONTENTS (CONT'D)

WP Sequence No.

CHAPTER 3 - UNIT, DIRECT SUPPORT AND GENERAL SUPPORT MAINTENANCE

INSTRUCTIONS (CONT'D)

Lube Oil Cooler, Removal, Cleaning, Inspection and Installation	0128 00
Lube Oil Cooler Bypass Valve, Removal, Cleaning, Inspection and Installation	0129 00
Lube Oil Level Dipstick Tube Assembly, Replacement	0130 00
Lube Oil Pressure Sending Unit, Replacement	0131 00
Lube Oil Temperature Switch, Replacement	0132 00
Fresh Water Cooling System, Servicing	0133 00
Fresh Water Cooling System, Flush	0134 00
Fresh Water Heat Exchanger, Cleaning	0135 00
Fresh Water Cooling System, Pressure Testing	0136 00
Fresh Water Cooling System Heat Exchanger, Removal, Cleaning, Inspection and Installation.....	0137 00
Fresh Water Cooling System Heat Exchanger, Removal and Installation	0138 00
Forward Lifting Bracket, Replacement	0139 00
Fresh Water Cooling System Filter Element, Replacement	0140 00
Fresh Water Cooling System Filter Head Cover, Replacement	0141 00
Fresh Water Cooling System Filter Head Cover Mounting Bracket, Replacement	0142 00
Fresh Water Cooling System Thermostat, Replacement	0143 00
Fresh Water Cooling System Starboard Thermostat Housing, Replacement	0144 00
Fresh Water Cooling System Port Thermostat Housing, Replacement	0145 00
Fresh Water Cooling System Thermostat, Testing	0146 00
Fresh Water Temperature Sending Unit, Replacement	0147 00
Fresh Water Cooling System Bypass Hoses, Replacement	0148 00
Fresh Water Cooling System Coolant Hoses, Replacement	0149 00
Fresh Water Cooling System Port Water Outlet Manifold, Replacement	0150 00
Fresh Water Cooling System Starboard Water Outlet Manifold, Replacement	0151 00
Fresh Water Cooling System Pump, Removal and Installation	0152 00
Fresh Water Cooling System Pump Drive Gear, Replacement	0153 00
Fresh Water Cooling System Pump, Repair	0154 00
Aftercooler, Replacement	0155 00
Fuel Cooler Zinc Anode Plug, Replacement	0156 00
Marine Gear Cooler Zinc Anode Plug, Replacement	0157 00
Heat Exchanger Zinc Anode Plug, Replacement	0158 00
Raw Water Pump Zinc Anode Plug, Replacement	0159 00
Raw Water Pump, Removal and Installation	0160 00
Raw Water Pump, Repair	0161 00
Raw Water Pump Seal, Replacement	0162 00
Exhaust Manifold, Replacement	0163 00
Marine Gear Oil Cooler Mounting Bracket, Replacement	0164 00
Electrical System Normal Stop Push Button, Replacement	0165 00
Electrical System Normal Stop Push Button Mounting Bracket, Replacement	0166 00
Electrical System Hour Meter, Replacement	0167 00
Electrical System Hour Meter Mounting Bracket, Replacement	0168 00
Starter Relay, Replacement	0169 00
Starting Motor, Replacement	0170 00
Cold Pac Starting Aid, Replacement	0171 00
Cold Start Temperature Switch, Replacement	0172 00
Tachometer Sending Unit, Replacement	0173 00

TABLE OF CONTENTS (CONT'D)

WP Sequence No.

CHAPTER 3 - UNIT, DIRECT SUPPORT AND GENERAL SUPPORT MAINTENANCE

INSTRUCTIONS (CONT'D)

Tachometer Drive, Replacement0174 00
Overspeed Governor, Replacement and Adjustment0175 00
Auto Shutdown System Emergency Stop Solenoid, Replacement0176 00
Auto Shutdown System High Water Temperature Switch, Replacement0177 00
Auto Shutdown System Low Oil Pressure Switch, Replacement0178 00
Auto Shutdown System Fuel Oil Pressure Switch, Replacement0179 00
Pipe Nipples, Elbows, Tees, Adaptors and Plugs, Replacement0180 00
Electrical Wiring, Repair0181 00
Torque Limits Work Package0182 00
Wiring Diagrams0183 00

CHAPTER 4 - UNIT, DIRECT SUPPORT AND GENERAL SUPPORT SUPPORTING

INFORMATION

References0184 00
Maintenance Allocation Chart (MAC), Introduction0185 00
Maintenance Allocation Chart (MAC)0186 00
Expendable and Durable Items List (EDIL)0187 00
Tool Identification List (TIL)0188 00

INDEX

Alphabetical	INDEX-1
Wire Diagram Fold Outs	FO-1

HOW TO USE THIS MANUAL

This manual contains certain features to improve the convenience of using this manual and increase the user's efficiency. These features include:

a. Accessing Information

Information is accessed by referring to the Table of Contents, located in the front of this manual, or by looking in the Alphabetical Index, located in the back of this manual.

b. Illustrations

Various methods are used to locate and repair components. Locator illustrations in Controls and Indicator tables, PMCS tables, exploded views and cut-away diagrams make the information in the manual easier to understand and follow.

c. Using This Manual

When using this manual, read and understand the entire maintenance action before performing the task. Also, read and understand all warnings, cautions and notes as well as general safety precautions that apply to the task to be performed. The warning summary will inform personnel of hazards associated with the equipment to be worked on. However, the summary is not all inclusive and personnel should be aware at all times of hazardous conditions that may arise.

Prior to starting the procedures in this manual, the initial setup requirements are located directly above each procedure. The information is given to ensure all materials, expendables, tools and any other equipment necessary are readily available for use. The initial setup will be accomplished prior to starting the actual steps of each maintenance procedure.

Locating Major Components

Obtain the manual for the system to be worked on. Open to the Table of Contents located in the front of this manual. Find Chapter 1, *Description and Theory of Operation*. Under the chapter title you will find the work package titled *Location and Description of Major Components*. Turn to the work package indicated. This work package will give a brief description of the major components, and show an illustration of what the component looks like and its location.

The Alphabetical Index, located in the back of this manual, contains an alphabetical list of all sections of this manual. *Location and Description of Major Components* is found in section L. The work package is found on the right side of the title where the *Location and Description of Major Components* is located. Turn to the work package indicated to find the description and location of each component.

Troubleshooting Procedures

The Table of Contents or Alphabetical Index may be used to locate sections within this manual. To locate a particular troubleshooting procedure, open the manual to the Table of Contents located in the front of this manual. Find Chapter 2, *Troubleshooting Procedures*. Under this section, find a work package titled *Troubleshooting Index*. Turn to the work package indicated, which lists all of the troubleshooting procedures. Look down the list until you find the appropriate work package for the problem you are trying to solve. To the right side of the procedure will be a work package number. Turn to the work package indicated and follow the steps to complete the troubleshooting procedure. The procedures list the malfunction, symptom and the corrective action. The corrective action will indicate which maintenance procedure to go to for the repair of the symptom or what level of maintenance is capable of repair of the problem. Follow the procedures indicated to complete the task. At the top of the task you will have a section called INITIAL SETUP. There are five basic headings listed under INITIAL SETUP.

Test Equipment: Lists all test equipment (standard or special) required to troubleshoot, test and inspect the equipment covered in this manual. The test equipment is identified with an item number and work package number from the *Tool Identification List* located in Chapter 4, *Supporting Information*.

Tools: Lists all tools (standard or special) required to perform the task. Tools are identified with an item number and work package number from the *Tool Identification List* located in Chapter 4, *Supporting Information*.

Personnel Required: Lists all personnel necessary to perform the task.

Equipment Condition: Notes the conditions that must exist before starting the task. The equipment condition will also include any prerequisite maintenance tasks to be performed with reference to the work package number or to the TM number.

References: Includes any other manuals necessary to complete the task. When there are no references listed, all steps necessary to complete the task are contained within this manual. A listing of reference materials is contained in the work package *References* in Chapter 4, *Supporting Information*.

Maintenance Instructions

To locate a maintenance procedure, open the manual to the Table of Contents located in the front of this manual. Find Chapter 3, *Maintenance Instructions*. Look down the list and find the maintenance procedure to be accomplished. On the right side of the maintenance procedure will be a work package number. Turn to the work package indicated. Before beginning the maintenance task, look through the procedure to familiarize yourself with the entire maintenance procedure. At the top of the task you will have a section called INITIAL SETUP. There are five basic headings listed under INITIAL SETUP.

Tools: Lists all tools (standard or special) required to perform the task. Tools are identified with an item number and work package number from the *Tool Identification List* located in Chapter 4, *Supporting Information*.

Materials/Parts: Lists all parts or materials necessary to perform the task. Expendable and durables are identified with an item number from the applicable work package located in Chapter 4, *Supporting Information*.

Personnel Required: Lists all personnel necessary to perform the task.

References: Includes any other manuals necessary to complete the task. When there are no references listed, all steps necessary to complete the task are contained within this manual. A listing of reference materials is contained in the work package *References* in Chapter 4, *Supporting Information*.

Equipment Condition: Notes the conditions that must exist before starting the task. The equipment condition will also include any prerequisite maintenance tasks to be performed with reference to the work package number or to the TM number.

Test Equipment: Lists all test equipment (standard or special) required to troubleshoot, test and inspect the equipment covered in this manual. The test equipment is identified with an item number and work package number from the *Tool Identification List* located in Chapter 4, *Supporting Information*.

Repair Parts and Special Tools List

Refer to TM 55-1945-205-24P-1 when requisitioning parts, special tools and equipment.

Identify the mandatory repair parts required to perform this task listed at the top of the work package in the INITIAL SET-UP. Using the part number provided, refer to the part number index work package in TM 55-1945-205-24P-1. Look up the part number in the part number column and identify the figure and item number where the part is located. Turn to the figure and locate the item number listed. Verify that the item is correct.

CHAPTER 1

DESCRIPTION AND THEORY OF OPERATION
FOR
MODULAR CAUSEWAY SYSTEM (MCS)
CAUSEWAY FERRY (CF) ENGINE

**UNIT, DIRECT SUPPORT AND GENERAL SUPPORT MAINTENANCE
CAUSEWAY FERRY
ENGINE
GENERAL INFORMATION**

SCOPE

This manual contains descriptions and maintenance instructions for the causeway ferry (CF) engine.

Type of Manual: Unit, Direct Support and General Support Maintenance Manual.

Purpose of Equipment: The CF engine is a Detroit Diesel 8V92TA and is the source of power for propulsion and maneuverability of the CF. The CF engine is the first component of the CF drive train which consists of a marine gear, transfer case and pump-jet, which is connected by driveshafts.

MAINTENANCE FORMS, RECORDS AND REPORTS

Department of the Army forms and procedures used for equipment maintenance will be those prescribed by DA PAM 738-750, Functional Users Manual for The Army Maintenance Management System (TAMMS) and AR 700-138, Army Logistics Readiness and Sustainability.

REPORTING EQUIPMENT IMPROVEMENT RECOMMENDATIONS (EIR)

If any component in your system needs improvement, let us know. Send us an EIR. You, the user, are the only one who can tell us what you don't like about your equipment. Let us know why you don't like the design or performance. Put it on an SF 368, Product Quality Deficiency Report. Mail it to the address specified in DA PAM 738-750, or as specified by the contracting activity. We will send you a reply.

CORROSION PREVENTION AND CONTROL (CPC)

CPC of Army materiel is a continuing concern. It is important that any corrosion problems with this item be reported so that the problem can be corrected and improvements can be made to prevent the problem in future items.

While corrosion is typically associated with rusting of metals, it can also include deterioration of other materials, such as rubber and plastic. Unusual cracking, softening, swelling or breaking of the materials may be a corrosion problem. If a corrosion problem is identified, it can be reported using SF 368, Product Quality Deficiency Report. Use of key words, such as "corrosion", "rust", "deterioration" or "cracking", will ensure that the information is identified as a CPC problem. The form should be submitted to the address specified in DA PAM 738-750, Functional Users Manual for The Army Maintenance Management System (TAMMS).

OZONE DEPLETING SUBSTANCES (ODS)

The continued use of ODS has been prohibited by Executive Order 12856 of 3 August 1993.

DESTRUCTION OF ARMY MATERIEL TO PREVENT ENEMY USE

The procedures for destruction of Army materiel to prevent enemy use are contained in TM 750-244-6.

LIST OF ABBREVIATIONS/ACRONYMS

Abbreviation/Acronym	Name
A	Annually
AC	Alternating Current
AL	Adaptor Length
AR	Army Regulation
AT	Applied Torque
AOAP	Army Oil Analysis Program
attn	Attention
BII	Basic Issue Items
BOT	Bottle
C	Centigrade
CAGEC	Commercial and Government Entity Code
CCW	Counterclockwise
CF	Causeway Ferry
CFR	Code of Federal Regulations
cm	Centimeters
CO2	Carbon Dioxide
CPC	Corrosion Prevention Control
CTA	Common Table of Allowances
cu in.	Cubic Inches
cw	Clockwise
DA FORM	Department of the Army Form
DA PAM	Department of the Army Pamphlet
DC	Direct Current
deg	Degrees
dia	Diameter
DS	Direct Support
DSN	Digital Service Network
DT	Desired Torque
ea	Each
e.g.	For Example
E-Mail	Electronic Mail
F	Fahrenheit
FGC	Functional Group Code
fig.	Figure
FLOCS	Fast Lube Oil Change System
ft	Foot
ft lbs	Foot Pounds
GAA	Grease, Automotive and Artillery
gal	Gallon
GBR	Grease, Ball and Roller
GS	General Support
H	Hours Operated
Hg	Mercury
hp	Horse Power
IAW	In Accordance With
ID	Identification
i.e.	That Is
in.	Inches
in.Hg	Inches of Mercury
kg	Kilograms
in. lbs	Inch Pounds

LIST OF ABBREVIATIONS/ACRONYMS (CONTINUED)

Abbreviation/Acronym	Name
kPa	Kilopascals
L	Liter
lb	Pounds
LT	Length of Torque Wrench
M	Monthly
mA	Milliampere
MAC	Maintenance Allocation Chart
MCS	Modular Causeway System
ML	Milliliters
mm	Millimeters
NHA	Next Higher Assembly
N-m	Newton-Meters
no.	Number
NSN	National Stock Number
ODS	Ozone Depleting Substance
oz.	Ounces
pkg	Package
PMCS	Preventive Maintenance Checks and Services
PN	Part Number
PPM	Parts Per Million
PSI	Pounds Per Square Inch
pwr	Power
Q	Quarterly
qt	Quart
qty	Quantity
RPM	Revolutions Per Minute
RPSTL	Repair Parts and Special Tools List
S	Semi-Annually
SAE	Society of Automotive Engineers
SC	Supply Catalog
SCA	Supplemental Coolant Additive
SF	Standard Form
SINCGARS	Single Channel Ground and Airborne Radio
SMR	Source Maintenance Recoverability Code
SQDR	Square Drive
SRA	Specialized Repair Activity
stbd	Starboard
TACOM	(USA) Tank And Automotive Command
TAMMS	The Army Maintenance Management System
TB	Technical Bulletin
TIR	Total Indicator Reading
TM	Technical Manuals
TMDE	Test, Measurement and Diagnostic Equipment
UM	Unit of Measure
UUT	Unit Under Test
VAC	Voltage, Alternating Current
VDC	Voltage, Direct Current
W	Width
WP	Work Package

**UNIT, DIRECT SUPPORT AND GENERAL SUPPORT MAINTENANCE
CAUSEWAY FERRY
ENGINE
DESCRIPTION AND DATA**

EQUIPMENT CHARACTERISTICS, CAPABILITIES AND FEATURES

DIESEL ENGINE

The diesel engine is an eight cylinder, water-cooled, turbocharged, aftercooled, two cycle marine engine delivering 600 hp at 2100 RPM. The engine provides power to the drive train which consists of an engine, marine gear, transfer case and pump-jet connected by driveshafts. Operator control of the engine is accomplished from the operators cab, with the exception of below deck emergency stop push buttons and emergency stop actuation control of the fire suppression system.

UNIT, DIRECT SUPPORT AND GENERAL SUPPORT MAINTENANCE
CAUSEWAY FERRY
ENGINE
DESCRIPTION AND DATA

LOCATION AND DESCRIPTION OF MAJOR COMPONENTS

The diesel engine is an eight cylinder, water-cooled, turbo charged, after cooled, two cycle marine engine delivering 600 hp at 2100 RPM. The engine is located in the machinery compartment of the CF propulsion module. The engine contains the cooling system, fuel system, electrical system, governing system, air system and exhaust components which includes a water cooled muffler just aft of the engine.

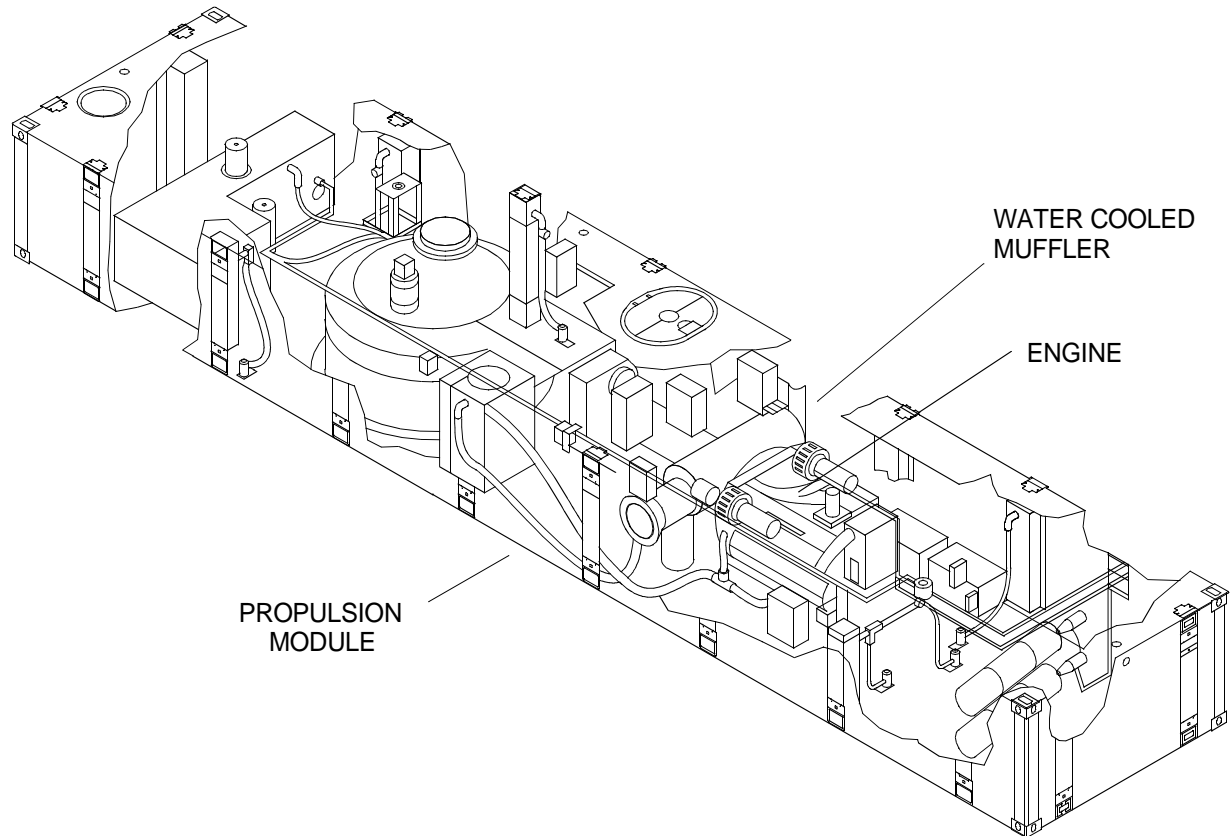

The engine provides power to the drive train, which consists of a marine gear, transfer case and pump-jet connected to each other by driveshafts. Control of the engine is accomplished from the operators cab, with the exception of below deck emergency stop push buttons and emergency stop actuation control of the fire suppression system.

EXTERNAL COMPONENTS

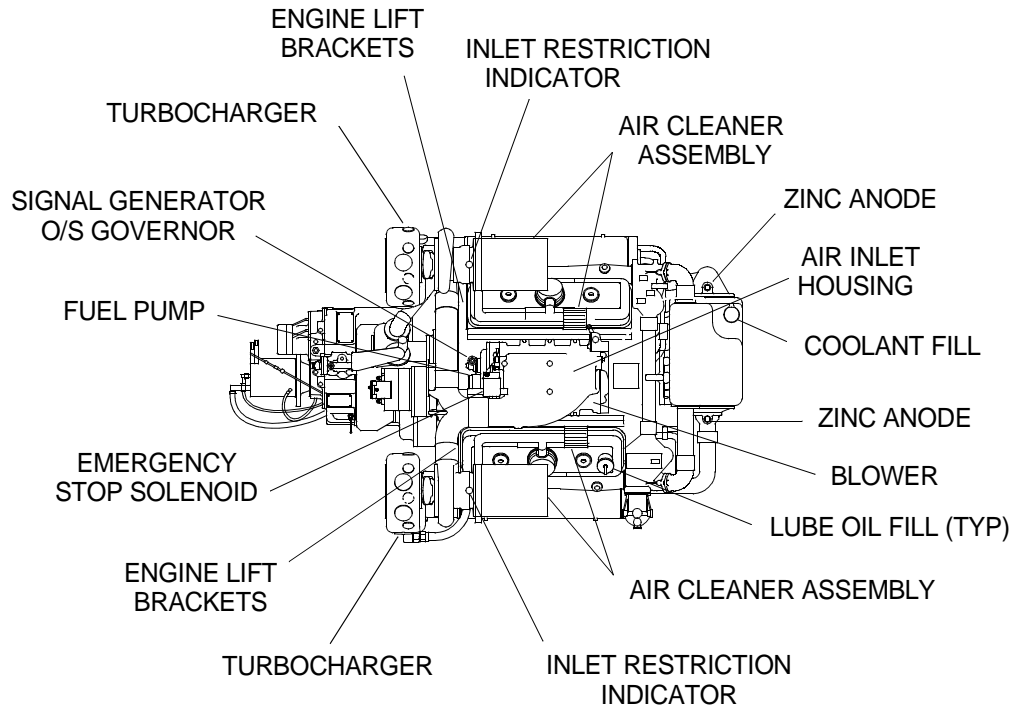

DIESEL ENGINE COMPONENTS, TOP VIEW

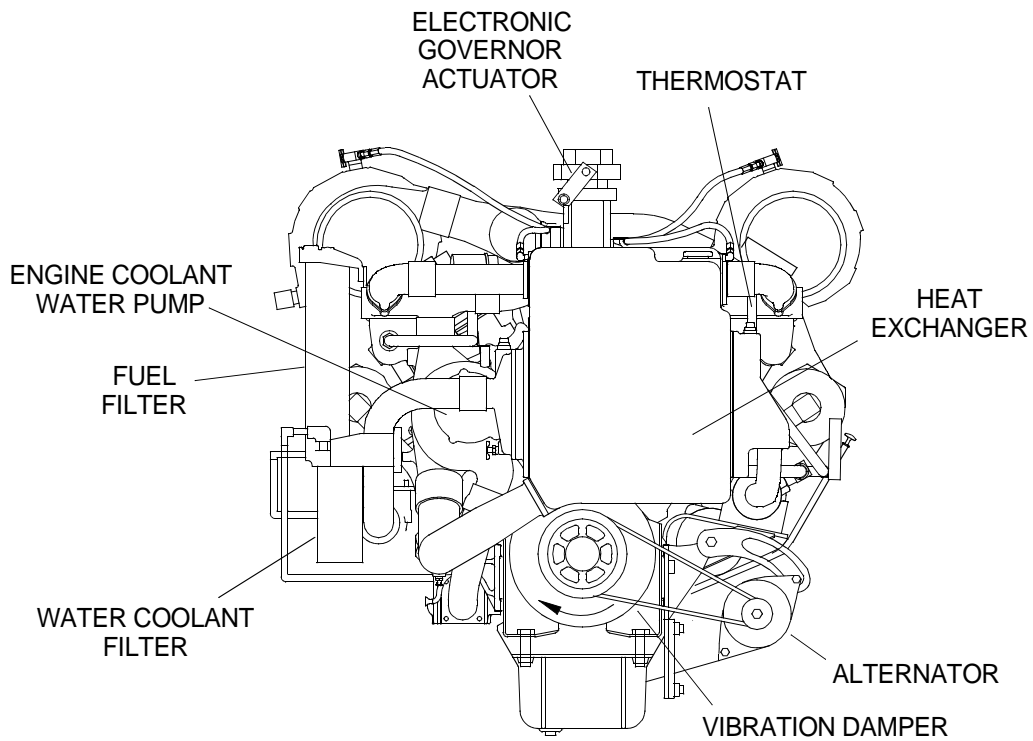

DIESEL ENGINE COMPONENTS, FORWARD VIEW

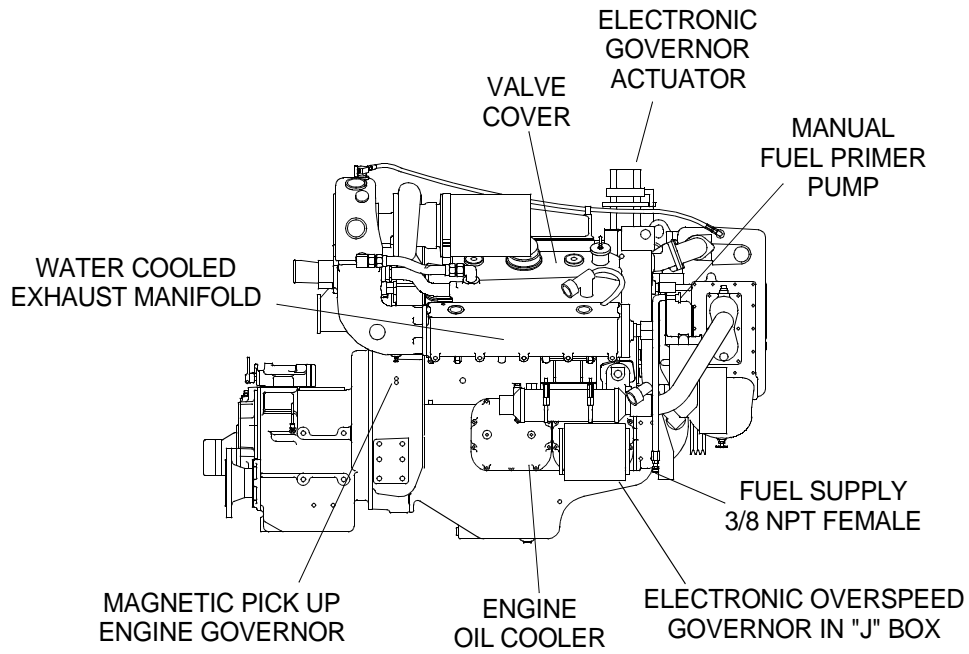

DIESEL ENGINE COMPONENTS, STARBOARD SIDE VIEW

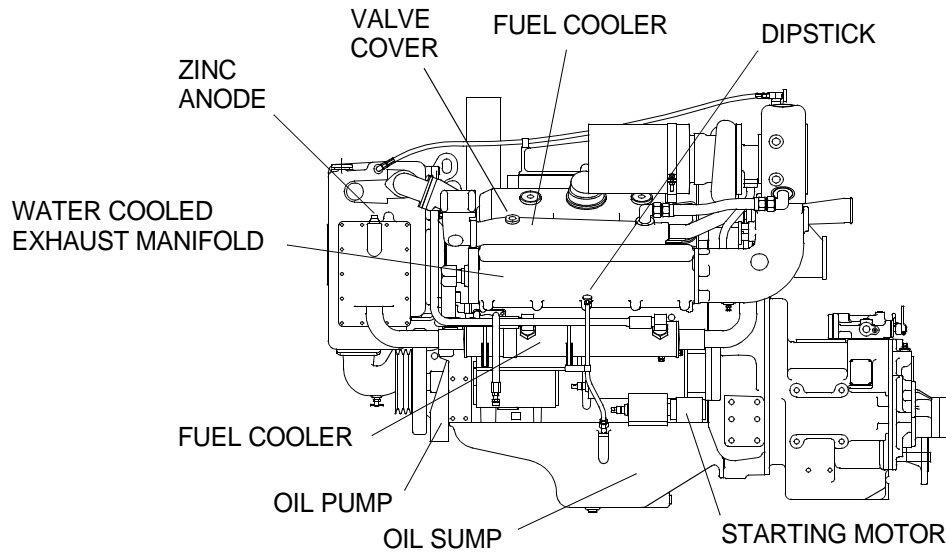

DIESEL ENGINE COMPONENTS, PORT SIDE VIEW

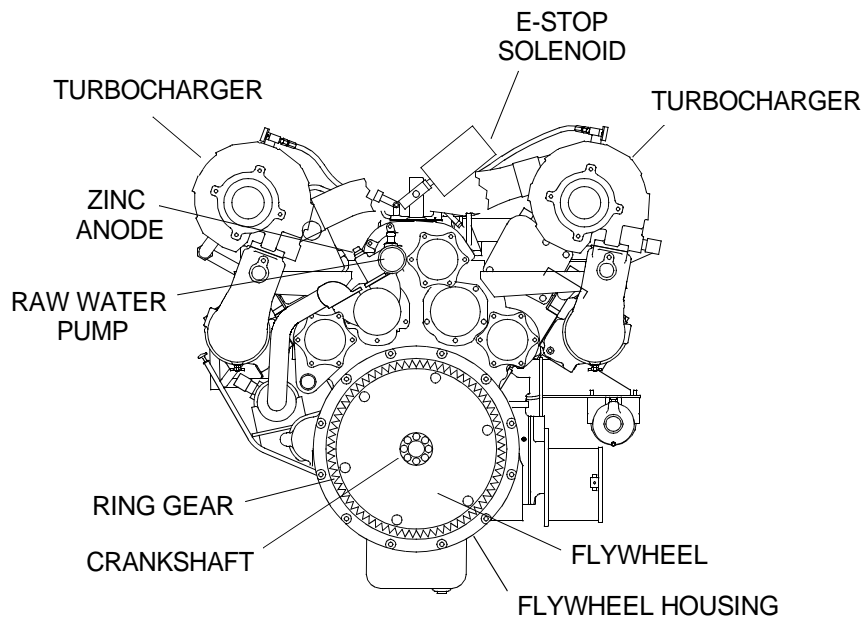

DIESEL ENGINE COMPONENTS, AFT VIEW

Cooling System

Coolant is circulated through the engine by a centrifugal-type water pump, which is located on the forward end of the engine. Heat is removed from the coolant, which circulates in a closed system, by the heat exchanger also on the forward end of the engine. Control of the engine temperature is accomplished by thermostats located on the forward end of the engine, which regulate the flow of the coolant within the cooling system. The closed cooling system filter is located on the forward starboard corner of the engine, which cleans the coolant of dirt, sediment and oxidation. The coolant level is checked and filled through a cap located on the top of the heat exchanger.

The engine raw water cooling system consists of a sea chest, a butterfly valve and a duplex strainer which are all discussed in TM 55-1945-205-24-1-1. The engine raw water pump is located on the aft end of the engine, which circulates raw water through the entire raw water system. The fuel cooler is located on the port side of the engine. The marine gear oil cooler is located on the starboard side of the engine.

Fuel System

The fuel system is an integrated part of the diesel engine. The fuel is pumped by a gear type fuel pump located on the aft end of the engine blower. The fuel is cleaned by a fuel filter located on the starboard side of the engine. Fuel injectors, located in the cylinder heads, properly meter the fuel to the engine. Fuel manifolds, located in the cylinder head casting, supply an ample amount of fuel for the injectors to draw from. The excess fuel is then pumped through the fuel cooler located on the port side of the engine where it is cooled prior to being sent back to the fuel in storage.

Lubrication System

Full pressure lubrication is supplied to all main, connecting rod and camshaft bearings and to other moving parts within the engine. A gear-type pump located on the front end of the engine behind the vibration damper, draws oil from the oil sump located on the bottom of the engine through an intake screen. It is then pumped through the oil filter located remotely on the starboard bulkhead and then to the oil cooler located on the starboard side of the engine. From the oil cooler, the oil flows through passages that connect with the oil galleries in the cylinder block and cylinder heads for distribution to the bearings, rocker arm mechanism and other functional internal parts. The oil level is checked through a dipstick on the port side of the engine and is filled through oil filler cap on the starboard valve cover. The oil pressure is regulated by an oil pressure regulator located on the bottom side of the engine inside the oil sump. The engine is protected from excessive oil pressure by an oil pressure relief valve also located on the bottom side of the engine in the oil sump.

Electrical System

Engine starting is provided by an electric starting system. The electric starting motor, located on the port side of the engine, is energized by a storage battery. A battery-charging alternator, located port side forward corner of the engine, serves to keep the storage battery charged. The battery charging alternator is driven by a pulley mounted on the vibration damper, which is located on the forward end of the engine on the end of the crankshaft. An emergency stop solenoid, located on the aft end of the air inlet housing, activates a flapper in the air inlet housing when the air supply to the engine needs to be shut down.

Engine Governing System

Engine speed is controlled by a governor system. The governor system consists of a speed controller located in the engine junction box A4 aft of the engine, a governor actuator located on the top of the engine and a magnetic pick-up located on the aft end of the engine on the flywheel housing.

The engine is protected from over speed by an over speed governor. The over speed governor consists of an electronic speed switch located on the lower starboard side of the engine, a dual function signal generator which is located aft of the blower. The dual function signal generator transmits engine RPM's to both the over speed governor and the tachometer gauge.

Air Induction System

The air induction system begins with two paper type air filters located on top of the of the engine in front of the turbochargers and two air limiters located inboard of each valve cover on top of the engine. Two large volume water cooled turbochargers are located on the aft end both port and starboard sides of the engine. The air inlet housing mounted top center of the engine can shut off all air to the engine, shutting it down in an emergency situation. The engine blower located top center beneath the air intake housing maintains a constant pressure in the air box to maintain an efficient scavenging process. Located directly beneath the blower is an after cooler, which is a small radiator designed to cool and condense the air prior to entering the air box.

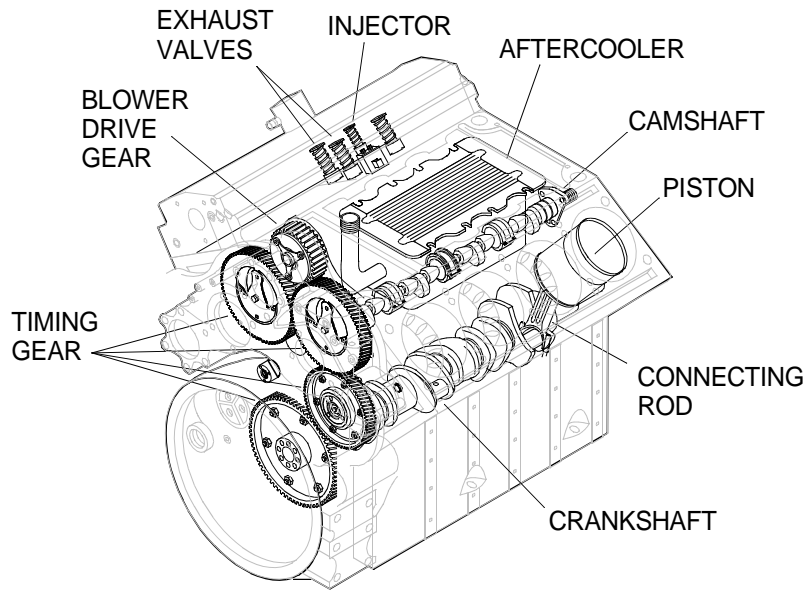
INTERNAL ENGINE COMPONENTS**Crankshaft Group**

The crankshaft is located on the lower center line of the engine and is used to convert the linear motion of the pistons to rotational torque which may be used by the rest of the drive train. The cross head pistons are located, four per side, in both the port and starboard banks of the engine block. The pistons connect to the crankshaft with a connecting rod.

Camshaft Group

The port and starboard camshafts are located just outboard of the after cooler, running parallel to the crankshaft, providing synchronous operation of the exhaust valves and the injectors, which are located on both port and starboard cylinder heads. The camshaft is driven by a timed set of gears located on the aft end of the engine which also drives the blower drive gear.

**UNIT, DIRECT SUPPORT AND GENERAL SUPPORT MAINTENANCE
CAUSEWAY FERRY
ENGINE
DESCRIPTION AND DATA**

EQUIPMENT DATA

The following tables provides data applicable to major component levels.

Table 1. CF Equipment Data.

ITEM CHARACTERISTIC	DESCRIPTION
ENGINE (2 PER SECTION)	
Model	Detroit Diesel 8V92TA
Rated Horse Power (Each)	600 HP at 2100 RPM at output shaft
Starting System	Electric (24 volt)
Number Of Cylinders	Qty 8
Electrical System	24 volt 65 amps
Firing Order	1L-3R-3L-4R-4L-2R-2L-1R
Total Displacement	736 cu in. (12.07 L)
Bore	4.84 (123 mm)
Stroke	5.0 in. (127 mm)
Number Of Main Bearings	Qty 5
Compression Ratio	17.0 to 1
Maximum Torque	1250 ft lbs (1695 N-m)
ENGINE SPEED RATINGS	
Maximum Governor Speed, Full Load	2100 ± 50 RPM
Minimum Idle Speed	600 ± 50 RPM
No-load Governed Speed	2250 ± 50 RPM
INTAKE	
Turbocharger	TV8101 with after cooler
Blower	Large bearing, gear driven, helical rotor blower
Air Cleaner	Dry element type
PISTONS AND CONNECTING RODS	
Piston Type	Cross-head piston with crown and skirt
Number Of Compression Rings	Qty 2
Number Of Fire Rings	Qty 1

Table 1. CF Equipment Data. (Continued)

ITEM CHARACTERISTIC	DESCRIPTION
Number Of Oil Rings	Qty 2
Type Piston Pin	Solid core type bushing
Type Bearing	Solid core type bushing
Type Cylinder Liner	Replaceable wet type, alloy cast iron
ENGINE LUBRICATING SYSTEM	
Crankcase Capacity	28 qt (26.5 L)
With Filter Change	30 qt (28.4 L)
Oil Pressure	50 to 70 PSI (344.7 to 482.6 kPa, 1.800 RPM)
Type System	Pressure and spray circulation
Oil Pump	Gear type
Oil Filter	Full flow, bolt on type with bypass valve
Oil Cooler	Plate type, with bypass valve
FUEL SYSTEM	
Fuel Pump	Positive displacement, gear-type
Limiting Speed Governor	Variable speed, single-weight mechanical type
Fuel Injectors	Model No. 9A90, needle valve type, valve opening pressure: 2200 to 3300 PSI (15 169 to 22 753.5 kPa)
Fuel Water Separator	Fuel strainer, density-type element
Secondary Fuel Filter	Fuel filter, paper-type element
COOLING SYSTEM	
Heat Exchanger Working Pressure	15 to 20 PSI (103 to 138 kPa)
Operating Temperature	160°F to 180°F

UNIT, DIRECT SUPPORT AND GENERAL SUPPORT MAINTENANCE
CAUSEWAY FERRY
ENGINE
THEORY OF OPERATION

THE DIESEL ENGINE

The diesel engine is an internal compression combustion power unit where the heat of the fuel and air is compressed and burned, thereby converting it into work in the cylinders of the engine.

In the diesel engine, air is compressed creating heat in the cylinder. The fuel is then injected into the compressed air igniting the diesel fuel which starts the power stroke or work.

THE TWO-CYCLE PRINCIPLE

The two-cycle engine has two strokes, the motion of the piston in one direction, or one rotation of the crankshaft for each cycle of the engine. In contrast, the four cycle engine has four strokes or two rotations of the crankshaft for each cycle of the engine.

How the Two-Cycle Principle Works

The diesel engine is provided with a blower to force air into the cylinders to provide fresh air for combustion and to expel exhaust gases. The cylinder liner contains a row of ports which are above the piston when it is at the bottom of its stroke. These ports allow air to enter from the blower as soon as the rim of the piston begins to uncover the ports. At the same time, the exhaust valves are open and a unidirectional flow of air from the liner ports to the exhaust valves accomplishes two vital processes. First, the exhaust gases are expelled from the cylinder and second, the cylinder is filled with fresh air for combustion.

The piston travels upward, covering and sealing the liner ports. As the piston continues upward it then compresses the air therefore creating heat. Just before the piston reaches the top of the stroke, fuel is then injected into the heated compressed air in the cylinder. The intense heat of the compressed air immediately ignites the fuel. The resulting combustion will continue until all of the fuel and air are depleted.

The resulting pressure forces the piston downward starting the power stroke. The resulting energy is converted from linear motion to rotating motion by the crankshaft. As the piston travels downward it will again uncover the liner ports and the exhaust valves will open allowing the incoming air to push the exhaust gases out starting the process over again. This entire process is completed in all eight cylinders once every rotation of the crankshaft.

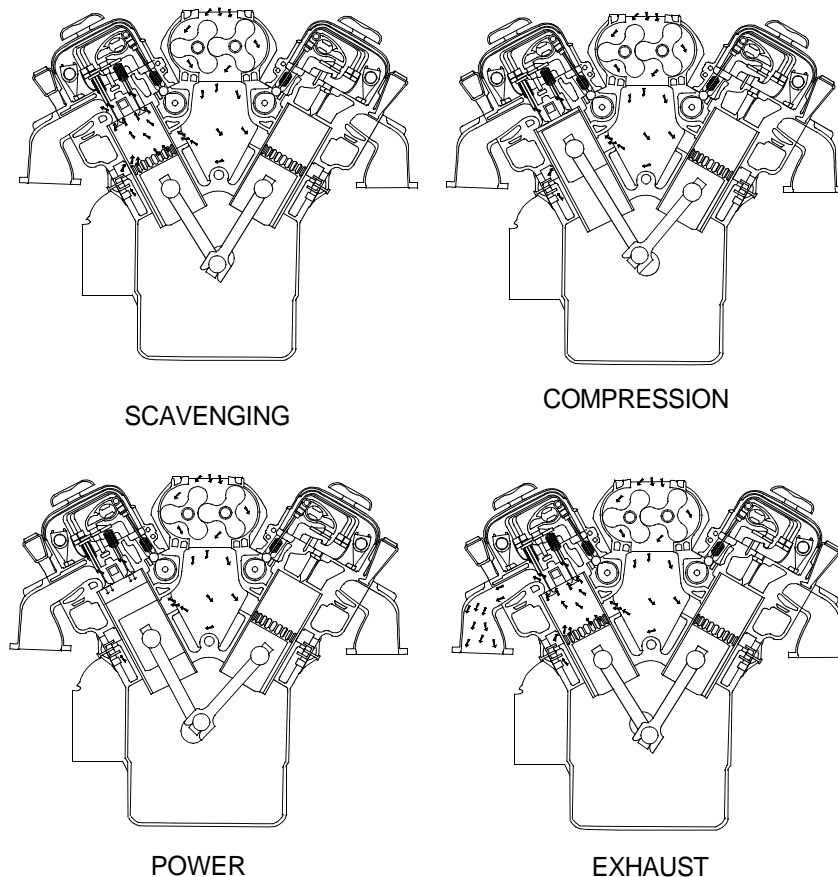

THE AIR INDUCTION SYSTEM

In the scavenging process employed by the 8V92TA engine, a charge of air is forced into the cylinders by the blower and thoroughly sweeps out all of the burned gases through the exhaust valve ports. This air also helps to cool the internal engine parts, particularly the exhaust valves, at the beginning of the compression stroke. Therefore, each cylinder is filled with fresh, clean air which provides for efficient combustion. The air, entering the blower from the air cleaner, is picked up by the blower rotor lobes and carried to the discharge side of the blower, as indicated by the arrows. The continuous discharge of fresh air from the blower enters the air chamber of the cylinder block and sweeps through the intake ports of the cylinder liners. The angle of the ports in the cylinder liners creates a uniform swirling motion to the intake air as it enters the cylinders. This motion persists throughout the compression stroke and facilitates scavenging and combustion.

The Air Filter

There are two dry type cone shaped air filters mounted to the air inlet side of each turbocharger. The dry type air cleaners are designed to provide highly efficient air filtration under all operating conditions. The air cleaners have a replaceable impregnated paper filter element that can be cleaned.

The Turbochargers

The T18A40 model turbocharger is designed to increase the over all efficiency of the engine. Power to drive the turbocharger is extracted from the waste energy in the engine exhaust gas. The turbocharger consists of a radial inward flow turbine wheel and shaft, a centrifugal compressor wheel and a center housing which serves to support the rotating assembly, bearings, seals, turbine housing and compressor housing. The center housing has connections for oil inlet and oil outlet fittings.

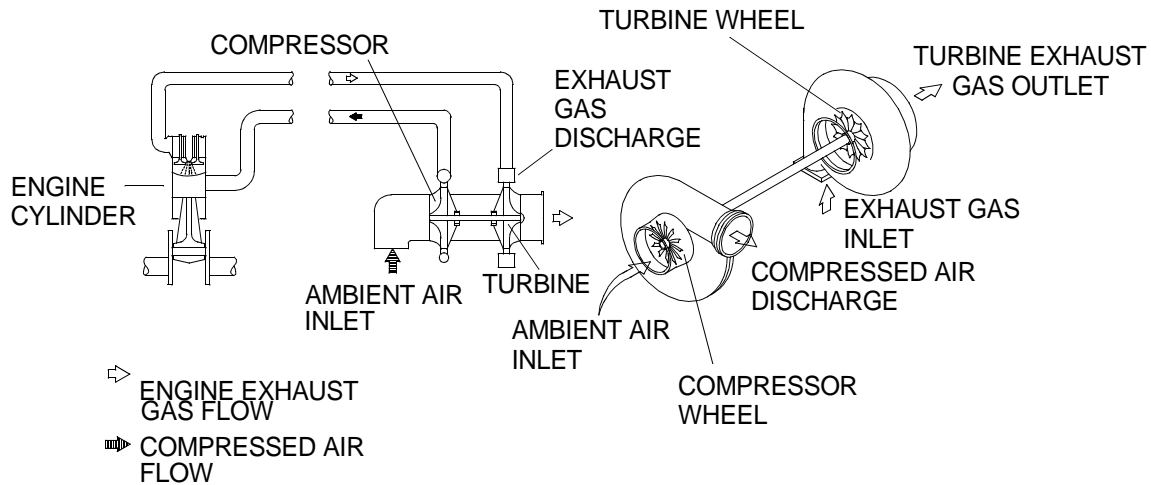

The turbocharger is mounted on the exhaust outlet flange of the engine exhaust manifold. After the engine is started, the exhaust gases flowing from the engine and through the turbine housing cause the turbine wheel and shaft to rotate. The gases are discharged into the atmosphere after passing through the turbine housing. The compressor wheel, which is mounted on the opposite end of the turbine wheel shaft, rotates with the turbine wheel. The compressor wheel draws in fresh air, compresses it and delivers high pressure air through the engine blower to the engine cylinders. During operation, the turbocharger responds to the engine load demands by reacting to the flow of the engine exhaust gases. As the engine power output increases or decreases, the turbocharger responds to the engine's demand to deliver the required amount of air under all conditions. An after cooler is used to cool the air going into the engine after it passes through both the turbocharger and engine blower.

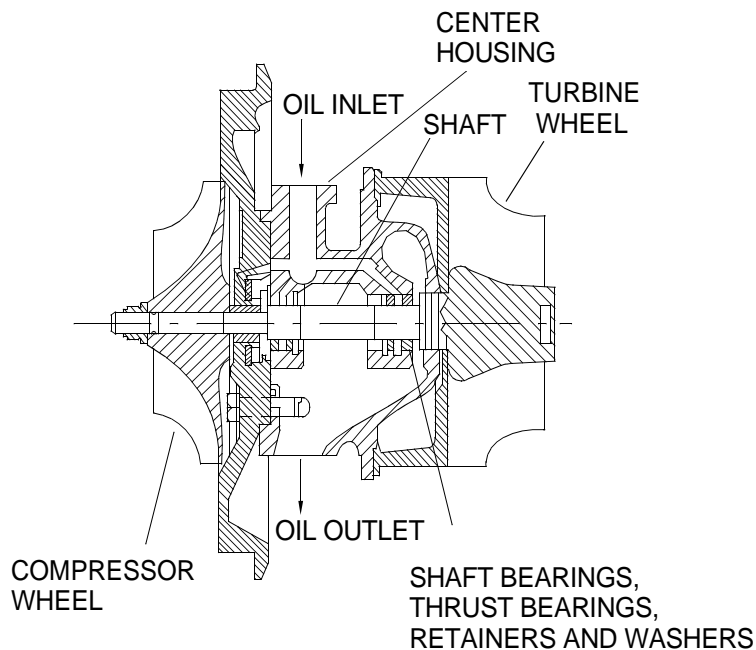

Lubricating oil for the turbocharger is supplied under pressure through an external oil line extending from the engine cylinder block to the top of the center housing. From the oil inlet in the center housing, the oil flows through the drilled oil passages in the housing to the shaft bearings and thrust bearings. The oil returns by gravity to the engine oil pan through an external oil line extending from the bottom of the turbocharger center housing to the cylinder block.

The Air Intake Housing

The air intake housing is mounted on the blower. A valve mounted inside of the housing may be closed to shut off the air supply and stop the engine when abnormal operating conditions require an emergency shut down.

The Blower

The large bearing blower, designed especially for efficient diesel operation, supplies the fresh air needed for combustion and scavenging. Its operation is similar to that of a gear-type oil pump. Two hollow three-lobe rotors revolve with very close clearances in a housing bolted to the top deck of the cylinder block, between the two banks of cylinders. To provide continuous and uniform displacement of air, the rotor lobes are made with a helical (spiral) form.

The three-piece seals were replaced by double lip teflon oil seals in 1986. Each rotor is supported in the doweled end plates of the blower housing by a roller bearing at the front end and a double-row radial and thrust ball bearing at the gear end. The right-hand helix rotor of the blower is driven by the blower drive shaft. The blower drive shaft is splined at one end to a drive hub attached to the blower drive gear and at the other end to a drive hub attached to the right-hand helix blower timing gear. The mating left-hand helix timing gear drives the left-hand helix rotor. Two timing gears, located on the drive end of the rotor shafts, space the rotor lobes with a close tolerance. Therefore, as the lobes of the two rotors do not touch at any time, no lubrication is required. This timing must be correct, otherwise the required clearance between the rotor lobes will not be maintained. A change in rotor timing is obtained by the use of shims between the gears and the bearings.

The blower bearings, timing gears, governor drive and fuel pump drive are pressure lubricated by oil passages in the top deck of the cylinder block which lead from the main oil galleries to an oil passage in each blower end plate. A cup shaped oil strainer has been incorporated in the vertical oil passage at the bottom side of each blower end plate to remove any foreign material in the lubricating oil. The oil flows upward in the end plate and leaves through a small orifice just above the center line of the end plate. The oil is ejected from this orifice against the timing gears at the rear and the governor weights at the front of the blower and is then carried by splash to the bearings. Oil, which collects at the bottom of each end plate, overflows into two drain passages which lead back to the crankcase via oil passages in the cylinder block. The blower drive support bearings receive oil under pressure from a tube which connects the oil passage in the rear end plate to passages in the blower drive support. Excess oil drains back to the crankcase by way of the gear train.

The Aftercooler

The aftercooler mounts in the cylinder block opening between the cylinders, beneath the blower assembly. The after cooler cools the air going into the engine after it passes through both the turbocharger and the blower. The air flows downward through the after cooler and the coolant flows from rear to front through the after cooler and returns through the left bank thermostat housing. The top deck of the cylinder block has been revised to accept the after cooler. A water inlet adaptor plug or cup plug replaces the rear 2 ½ in. core plug in the bottom of the cylinder block opening to supply water to the after cooler.

THE FUEL SYSTEM

The fuel system includes the fuel injectors, fuel pipes (inlet and outlet), fuel manifolds (integral with the cylinder head), fuel pump, fuel strainer, fuel filter and fuel lines.

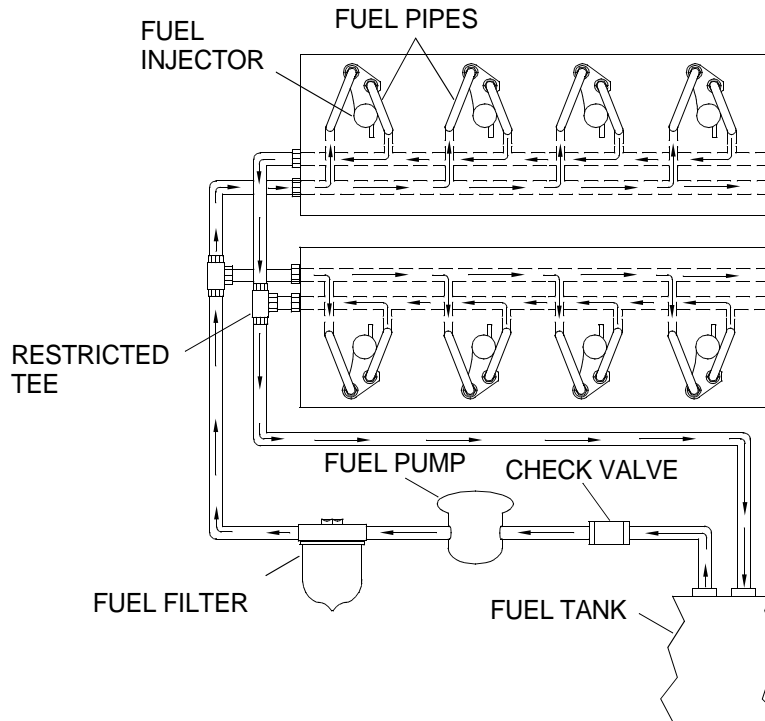

Fuel is drawn from the supply tank through the fuel strainer and enters the fuel pump at the inlet side. Leaving the pump under pressure, the fuel is forced through the fuel filter and into the inlet fuel manifold, then through fuel pipes into the inlet side of each fuel injector.

The fuel manifolds are identified by the words IN (top passage) and OUT (bottom passage) which are cast or stamped in several places on the side of the cylinder head. This aids installation of the fuel lines. Surplus fuel returns from the outlet side of the injectors to the fuel return manifold and then back to the supply tank.

All engines are equipped with a restrictive fitting in the fuel outlet manifold in one of the cylinder heads on the engines to maintain the fuel system pressure. A check valve may be installed in the supply line between the fuel tank and the fuel strainer to prevent fuel from draining back when the engine is shut down.

The Fuel Injectors

The fuel injector is a lightweight compact unit which enables quick, easy starting directly on diesel fuel and permits the use of a simple open type combustion chamber. The simplicity of design and operation provides for simplified controls and easy adjustment. No high pressure fuel lines or complicated air-fuel mixing or vaporizing devices are required. The fuel injector performs four functions (Times, Atomizes, Meters, and Pressurizes):

- Accurately times the moment of fuel injection.
- Atomizes the fuel for vaporization and mixing with the air in the combustion chamber.
- Meters and injects the correct amount of fuel required to maintain engine speed and to handle the load.
- Creates the high pressure required for proper fuel injection.

Combustion required for satisfactory engine operation is obtained by injecting, under pressure, a small quantity of accurately timed, metered and finely atomized fuel oil into the combustion chamber. Metering and timing during fuel injection is accomplished by an upper and lower helix machined in the lower end of the injector plunger. The continuous fuel flow through the injector serves, in addition to preventing air pockets in the fuel system, as a coolant for those injector parts subjected to high combustion temperatures.

To vary the power output of the engine, injectors having different fuel output capacities are used. The fuel output of the various injectors is governed by the effective stroke of the plunger and the flow rate of the spray tip. Since the helix angle and the plunger design determines the operating characteristics of a particular injector. It is imperative that the specified injectors are used for each engine. If injectors of different types are mixed in an engine, erratic operation will result and may cause serious damage to the engine or to the equipment which it powers.

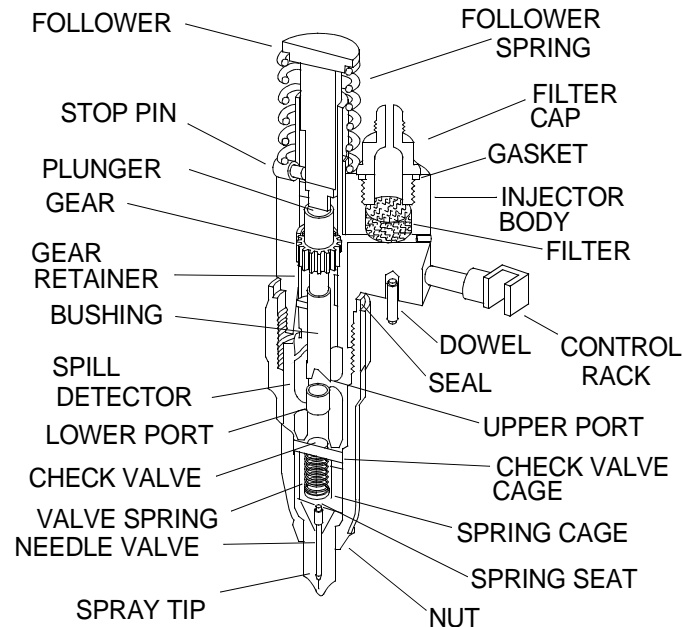

Each fuel injector has a circular disc pressed into a recess at the front side of the injector body for identification purposes. Each injector control rack is actuated by a lever on the injector control tube which, in turn, is connected to the governor by means of a fuel rod. These levers can be adjusted independently on the control tube, thus permitting a uniform setting or fine tuning of all injector racks. The fuel injector combines in a single unit all of the parts necessary to provide complete and independent fuel injection at each cylinder.

Fuel, under low pressure, enters the injector at the inlet side through a filter cap and filter positioned over the racks. From the filter, the fuel passes through a drilled passage into the supply chamber, that area between the plunger bushing and the spill deflector, in addition to that area under the injector plunger within the bushing. The plunger operates up and down in the bushing, and is supplied fuel through the two tunnel-shaped ports in the bushing wall. The motion of the injector rocker arm is transmitted to the plunger by the follower which bears against the follower spring. In addition to the reciprocating motion, the plunger can be rotated around its axis by the gear which meshes with the control rack. To accomplish fuel metering, an upper helix and a lower helix are machined in the lower part of the plunger. The helix relationship to the ports changes with the rotation of the plunger.

As the plunger moves downward, under pressure of the injector rocker arm, some of the fuel under the plunger moves into the supply chamber through the lower port until the port is covered by the lower end of the plunger. The fuel below the plunger continues to move up through a central passage in the plunger into the fuel metering recess and into the supply chamber through the upper port until that port is covered by the upper helix of the plunger. With the upper and lower ports both covered, the remaining fuel trapped under the plunger is subjected to increased pressure by the continued downward movement of the plunger.

When sufficient pressure is built up, it opens the flat check valve. The fuel in the check valve cage, spring cage, tip passages and tip fuel cavity is compressed until the pressure force acting upward on the needle valve is sufficient to open the valve against the downward force of the valve spring. As soon as the needle valve lifts off of its seat, the fuel is forced through the small orifices in the spray tip and atomized into the combustion chamber. When the lower land of the plunger uncovers the lower port in the bushing, the fuel pressure below the plunger is relieved and the valve spring closes the needle valve, ending injection.

A pressure relief passage has been provided in the spring cage to permit bleed-off of fuel leaking past the needle pilot in the tip assembly.

A check valve, directly below the bushing, prevents leakage from the combustion chamber into the fuel injector in case the valve is accidentally held open by a small particle of dirt. The injector plunger is then returned to its original position by the injector follower spring.

On the return upward movement of the plunger, the high pressure cylinder within the bushing is again filled with fuel oil through the ports. The constant circulation of fresh cool fuel through the injector renews the fuel supply in the chamber, helps cool the injector and also effectively removes all traces of air which might otherwise accumulate in the system and interfere with accurate metering of the fuel. The fuel injector outlet opening, through which the excess fuel oil returns to the fuel return manifold and then back to the fuel tank, is directly adjacent to the inlet opening.

Changing the position of the helices, by rotating the plunger, retards or advances the closing of the ports and the beginning and ending of the injection period. At the same time, it increases or decreases the amount of fuel injected into the cylinder. With the control rack pulled out all the way (no injection), the upper port is not closed by the helix until after the lower port is uncovered. Consequently, with the rack in this position, all of the fuel is forced back into the supply chamber and no injection of fuel takes place. With the control rack pushed all the way in (full injection), the upper port is closed shortly after the lower port has been covered, thus producing a maximum effective stroke and maximum injection. From this no injection position to full injection position (full rack movement), the contour of the upper helix advances the closing of the ports and the beginning of injection.

The Fuel Pump

The positive displacement gear-type fuel pump transfers fuel from the supply tank to the fuel injectors. The pump circulates an excess supply of fuel through the injectors, which purges the air from the system and cools the injectors. The unused portion of fuel returns to the fuel tank by means of a fuel return manifold and fuel return line.

The fuel pump cover and body are positioned by means of two dowels. The dowels aid in maintaining gear shaft alignment. The mating surface of the pump body and cover are perfectly flat ground surfaces. No gasket is used between the cover and body since the pump clearances are set up on the basis of metal-to-metal contact. A very thin coat of sealant provides a seal against any minute irregularities in the mating surfaces. Cavities in the pump cover accommodate the ends of the drive and driven shafts.

The fuel pump body is recessed to provide running space for the pump gears. Recesses are also provided at the inlet and outlet positions of the gears. A small hole permits the fuel oil in the inlet side of the pump to lubricate the relief valve at its outer end and to eliminate the possibility of a hydrostatic lock which would render the relief valve inoperative. Pressurized fuel contacts the relief valve and provides for relief of excess discharge pressures. Fuel re-enters the inlet side of the pump when the discharge pressure is great enough to move the relief valve back from its seat. A cavity provides escape for the fuel oil, which is squeezed out of the gear teeth as they mesh together on the discharge side of the pump. Otherwise, fuel trapped at the root of the teeth would tend to force the gears apart, resulting in undue wear on the gears, shafts, body and cover.

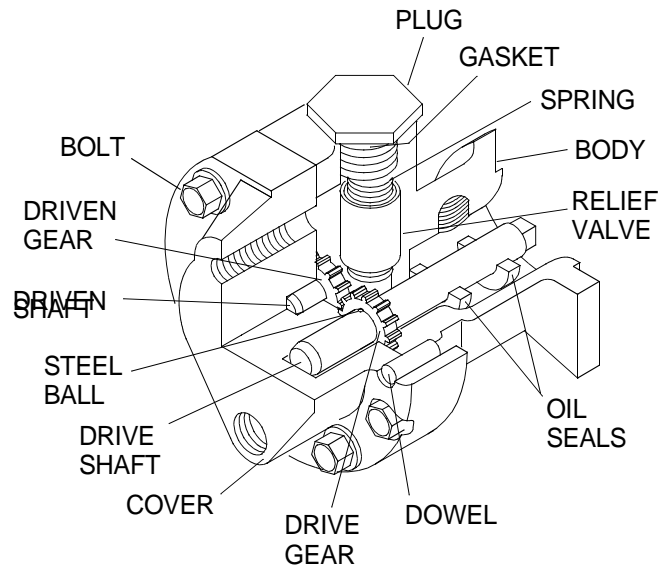

During operation, fuel enters the pump on the suction side and fills the space between the gear teeth, which are exposed at that instant. The gear teeth then carry the fuel oil to the discharge side of the pump and, as the gear teeth mesh in the center of the pump, the fuel oil is forced out into the outlet cavity. Since this is a continuous cycle and fuel is continually being forced into the outlet cavity, the fuel flows from the outlet cavity into the fuel lines and through the engine fuel system under pressure. The pressure relief valve relieves the discharge pressure by bypassing the fuel from the outlet side of the pump to the inlet side when the discharge pressure reaches approximately 65-75 PSI (448-517 kPa). The fuel pump should maintain the fuel pressure at the fuel inlet manifold.

The Fuel Filter

A spin-on type fuel filter is used. The spin-on filter cartridge consists of a shell, element and gasket combined into a unitized replacement assembly. No separate springs or seats are required to support the filter.

The filter cover incorporates a threaded sleeve to accept the spin-on filter cartridges. A fuel/water separator is installed to drain water residue. Water may also be drained removing and inverting the filter. Refill the filter with clean fuel oil before reinstalling it.

The Electronic Governor

The electronic governor system provides engine speed control in the place of mechanical linkages.

The actuator is a simple, proportional, electric solenoid having a sliding armature whose magnetic force is proportional to the input coil current. The armature glides on anti-friction bearings and is balanced between the force of the return spring and the magnetic force, thus providing a delay-free linear movement. The linear motion is converted to an output shaft rotation by a crank arm that is connected to the injector control rack linkage, thus controlling the fuel rate the engine is provided.

THE COOLING SYSTEM

To effectively dissipate the heat generated by the engine, a heat exchanger and raw water pump are used. The system is provided with a centrifugal type water pump that circulates the engine coolant. The system incorporates thermostats to maintain a normal engine operating temperature.

Upon starting a cold engine or when the coolant is below operating temperature, the coolant flow to the heat exchanger is blocked or restricted by the thermostats in the thermostat housings. A bypass provides coolant circulation within the engine during the warm-up period.

In the heat exchanger cooling system, the coolant is drawn by the engine water pump from the heat exchanger and is forced through the engine oil cooler, cylinder block, cylinder heads and exhaust manifolds to the thermostat housings. A bypass from the thermostat housings to the inlet side of the water pump permits circulation of coolant through the engine when the thermostats are closed. When the thermostats are open, the coolant flows through the heat exchanger where it is cooled. An engine driven raw water pump circulates raw water (sea water) through the heat exchanger to lower the temperature of the engine coolant.

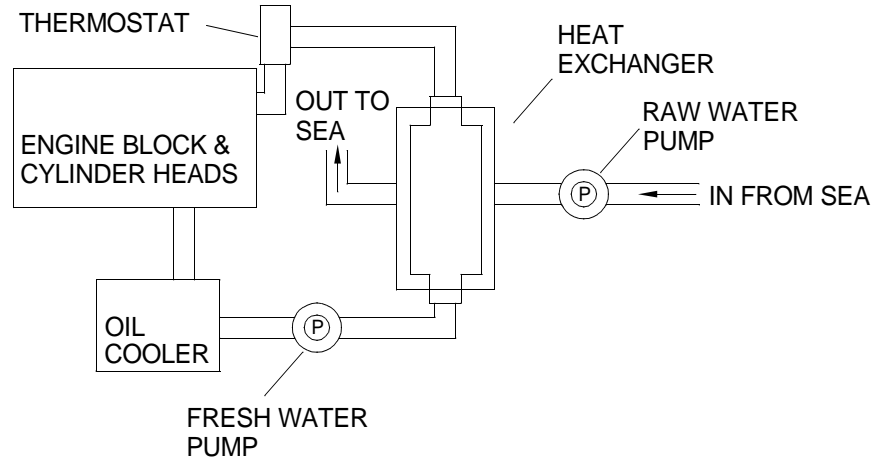

The Water Pump

The centrifugal-type water pump circulates the engine coolant through the cylinder block, cylinder heads, or heat exchanger and the oil cooler. The pump is mounted on the engine front cover and is driven by the 66 tooth front camshaft gear (water pump drive). The water pump gear has 42 teeth and meshes with the water pump drive gear. A bronze impeller is secured to one end of a stainless steel shaft by a lock nut. The water pump gear is pressed on the opposite end of the shaft. Two ball bearings are used to carry the shaft. The larger bearing is used at the drive gear end of the shaft to accommodate the thrust load. An oil seal is located in front of the smaller bearing and a spring-loaded face type water seal is used behind the impeller. The pump ball bearings are lubricated with oil splashed by the camshaft gear and the water pump gear.

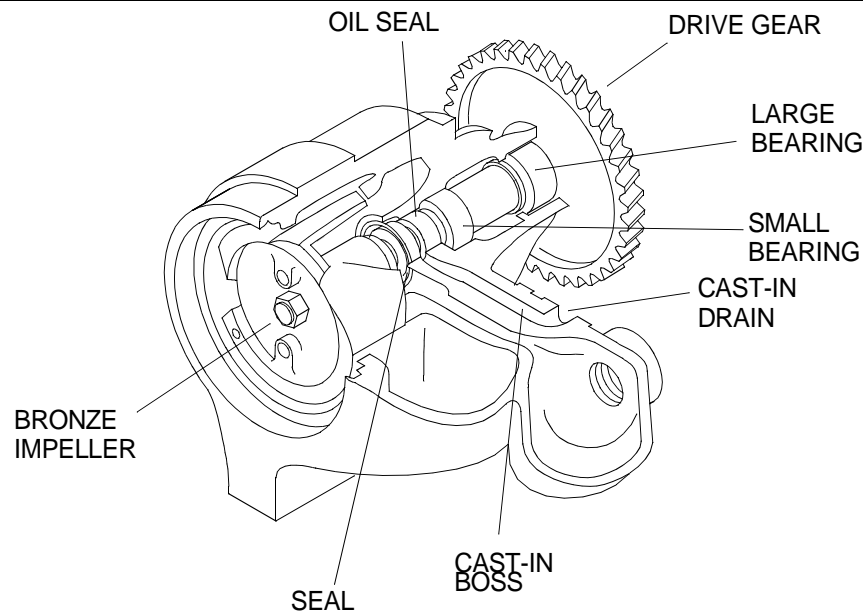

The Thermostat

The temperature of the engine coolant is automatically controlled by a thermostat located in a housing attached to the water outlet end of each cylinder head. Blocking type thermostats are used when a standard cooling system is employed. Two thermostats are employed by the 8V engines. At coolant temperatures below 160°-180°F (71°-82°C), depending upon the thermostat used, the valves remain closed and block the flow of coolant to the heat exchanger. During this period, all of the coolant in the standard system is circulated through the engine and is directed back to the suction side of the water pump via the bypass tube. As the coolant temperature rises above 160°-180°F (71°-82°C), the thermostat valves start to open, restricting the bypass system, and permit a portion of the coolant to circulate through the heat exchanger. When the coolant temperature reaches approximately 185°-197°F (85°-92°C) the thermostat valves are fully open, the bypass system is completely blocked off and all of the coolant is directed through the heat exchanger. A defective thermostat, which remains closed or only partially open, will restrict the flow of coolant and cause the engine to overheat. A thermostat which is stuck in a full open position may not permit the engine to reach its normal operating temperature. The incomplete combustion of fuel due to cold engine operation will result in excessive carbon deposits on the pistons, rings and valves. Properly operating thermostats are essential for efficient operation of the engine. If the engine operating temperature deviates from the normal range of 160°-197°F (71° -92°C), the thermostats should be removed and checked.

The Heat Exchanger

The heat exchanger core consists of a series of cells with a header at one end and a circular water outlet at the opposite end. The core is mounted inside of the expansion tank with the header or inlet end bolted to the tank and the opposite or outlet end is sealed inside a retainer. A gasket between the expansion tank and the flange of the core, another gasket between the flange of the core and the cover at the inlet side, and seals surrounding the circular outlet at the opposite end prevent the coolant from mixing with the raw cooling water on its horizontal course between the cells of the element. In this system of engine cooling, the hot coolant leaving the thermostat housing passes through the expansion tank, then through the cells of the cooling core. After leaving the heat exchanger, the engine coolant is picked up by the fresh water pump and circulated through the cylinder block and cylinder heads. The raw water is forced horizontally between the cells of the core and serves to lower the temperature of the coolant as it passes through the cells. To protect the heat exchanger core from electrolytic action of the raw water, a zinc electrode is located in both the heat exchanger inlet elbow and the raw water pump inlet elbow and extends into the raw water passage. The expansion tank provides a means of filling the engine cooling system, as well as space for expansion of

the coolant as its temperature rises. An overflow pipe, near the top of the tank, provides a vent to the atmosphere. The length of time a heat exchanger will function satisfactorily before cleaning will be governed largely by the kind of coolant used in the engine and the kind of raw water used. Soft water, plus a good commercial rust inhibitor or antifreeze should be used as the engine coolant to prevent lime deposits in the heat exchanger core as well as in the engine. Enough coolant should be maintained in the engine to fill the cylinder block and head and to partially fill the water tank. Allow air space above the coolant in the tank for the increase in volume as the temperature of the coolant rises. Whenever the heat exchanger fails to cool the engine properly, and the raw water pump is circulating a normal amount of cooling water around the heat exchanger core, the core should be examined for foreign deposits.

Raw Water Pump

Raw water for lowering the temperature of the engine coolant is circulated through the heat exchanger by a positive displacement pump. The pump is attached to an adaptor which, in turn, is bolted to the flywheel housing and is driven through a coupling attached to the left-hand camshaft gear. The pump drive shaft is supported by a pre-lubricated, shielded double-row ball bearing. An oil seal prevents oil leakage from the bearing compartment and a rotary type seal prevents water leakage along the shaft. An impeller, splined to the end of the drive shaft, is self-lubricated by the water pumped and should not be run dry for longer than normally required for the pump to prime itself. A wear plate in the impeller compartment prevents wear of the pump housing and can be reversed if wear on the plate becomes excessive. A slot machined in the outer periphery of the wear plate mates with a dowel in the pump housing, thus preventing it from rotating with the shaft. The pump can be operated in a clockwise or counterclockwise direction. Raw water is drawn into the pump through an inlet opening and discharged through the outlet opening, both openings are located at the top of the pump housing.

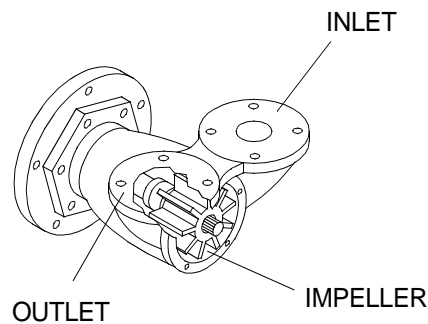

The Coolant Filter and Conditioner

The engine cooling system filter and conditioner is a compact bypass type unit with a replaceable a spin-on type element. A correctly installed and properly maintained coolant filter and conditioner provides a cleaner engine cooling system, greater heat dissipation and increased engine efficiency through improved heat conductivity and contributes to longer life of engine parts. The filter provides mechanical filtration by means of a closely packed element through which the coolant passes. Any impurities such as sand and rust particles suspended in the cooling system will be removed by the straining action of the element. The removal of these impurities will contribute to longer water pump life and proper operation of the thermostat. The filter also serves to condition the coolant by softening the water to minimize scale deposits, maintain an acid-free condition and act as a rust preventative. Corrosion inhibitors are placed in the element and dissolve into the coolant, forming a protective rustproof film on all of the metal surfaces of the cooling system. The other components of the element perform the function of cleaning and preparing the cooling passages while the corrosion inhibitors protect them.

THE LUBRICATION SYSTEM

The schematic illustrates the flow of oil through the 8V92TA engine lubrication system including the various components such as the oil pump, full-flow oil filter, oil cooler, pressure regulator and bypass valve.

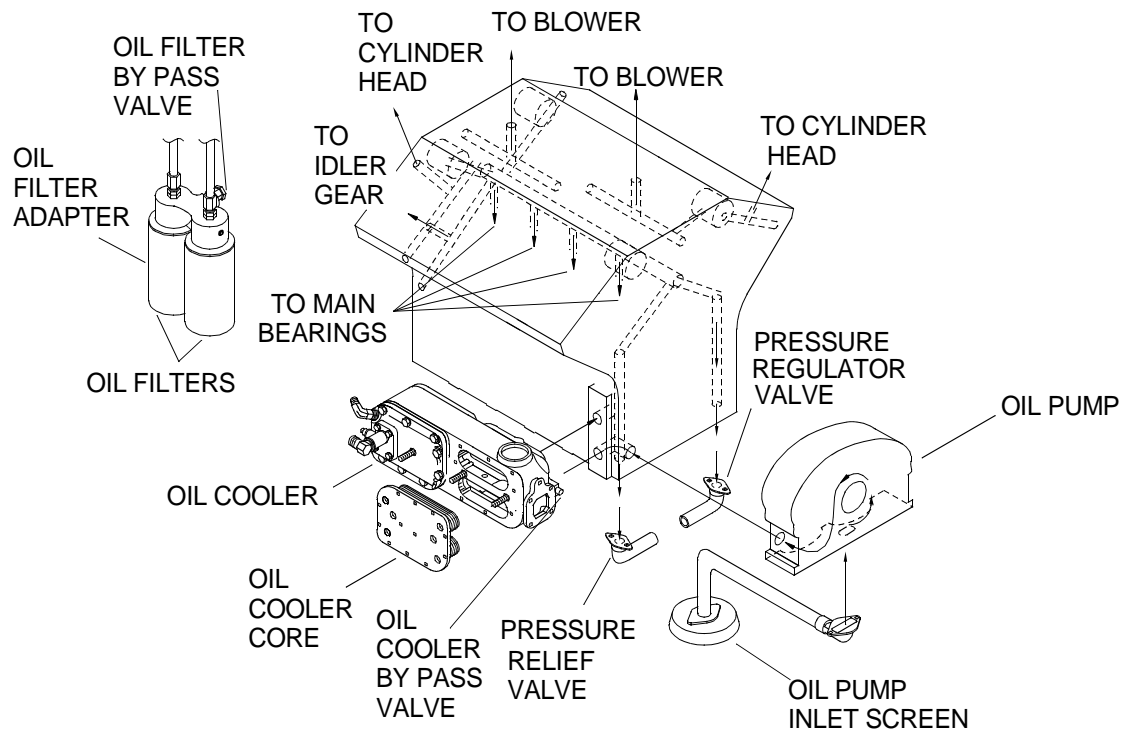

The oil pump is placed in the crankshaft front cover and consists of a pair of spur gears, one large and one small, which mesh together and ride in a cavity inside the crankshaft cover. The large gear is concentric with and splined to a pump drive hub on the front end of the crankshaft. The pump idler gear is much smaller and runs on a bushing and hardened steel shaft pressed into the crankshaft cover. The oil is drawn by suction from the oil pan through the intake screen and piped to the oil pump where it is pressurized. The oil then passes from the pump into a short gallery in the cylinder block to the oil cooler adaptor plate. At the same time, oil from the pump is directed to a spring-loaded pressure relief valve mounted on the cylinder block. This valve discharges excess oil directly to the oil sump when the pump pressure exceeds 105 PSI (724 kPa). From the oil cooler adaptor plate, the oil passes into the full-flow filter, through the oil cooler and then back into the cylinder block where a short vertical oil gallery and a short diagonal oil gallery carry the oil to the main longitudinal oil gallery through the middle of the block. Valves are also provided to bypass the oil filter and oil cooler should either one become plugged. Stabilized lubricating oil pressure is maintained within the engine at all speeds, regardless of the oil temperature, by means of a pressure regulator valve located at the end of a vertical oil gallery connected to the main oil gallery. This vertical gallery is located at the front of the cylinder block on the side opposite the cooler. When the oil pressure at the valve exceeds 50 PSI (345 kPa) the regulator valve opens, discharging oil back into the sump.

From the main oil gallery, the pressurized oil flows through drilled passages to each main bearing then passes to an adjacent pair of connecting rods by means of grooves in the unloaded halves of the main and connecting rod bearings and drilled passages in the crankshaft. The rifle drilled connecting rods carry oil from the rod bearings to the piston pin bushing. At the rear of the block, two diagonally drilled oil passages, which intersect the main oil gallery, carry oil to the two rear camshaft end bearings. Oil is then conducted through the rifle drilled camshaft to the intermediate and front end bearings. Oil from the camshaft intermediate bearings is directed against the camshaft lobes and cam rollers which run in an oil bath. This oil from the intermediate bearings provides lubrication of the cam lobes immediately after starting the engine when the oil is cold and before camshaft bearing oil flow and oil drainage from the cylinder head have had time to build up. The diagonally drilled oil passage on the right side at the rear of the block intersects with a vertical passage to carry oil to the right bank cylinder head. A short gallery also intersects with this diagonal

passage to lubricate the idler gear bearing. Another gallery intersecting the diagonal passage from the camshaft at the front of the block supplies oil to the left bank cylinder head. Drilled passages, intersecting longitudinal galleries which parallel the camshafts, lead to the blower and supply oil for the blower drive gears and bearings.

Oil from the right-bank camshaft front end bearing lubricates the water pump drive gear and bearings and the front camshaft gear. The gear train is lubricated by the overflow of oil from the camshaft pocket spilling into the gear train compartment and by splash from the oil pan. A certain amount of oil also spills into the gear train compartment from both camshaft rear end bearings, the blower drive gear bearing and the idler gear bearing. The blower drive gear bearing is lubricated through an external pipe from the blower rear end plate to the blower drive support. The valve and injector operating mechanism is lubricated from a longitudinal oil passage, on the camshaft side of each cylinder head, which connects to the main oil gallery in the cylinder block. Oil from this passage enters the drilled rocker arm shafts through the lower end of the rocker shaft bolts and rocker shaft brackets. Excess oil from the rocker arms lubricates the exhaust valves and cam followers.

The Oil Pump

The gear type lubricating oil pump is mounted in the crankshaft front cover, which also functions as the oil pump body. The pump consists of two spur gears which mesh and rotate in a cavity inside the crankshaft cover. The pump drive gear is concentric with and splined to a pump drive hub on the front end of the crankshaft. The pump driven gear and bushing assembly rotates on a hardened steel shaft. One end of the driven gear shaft is pressed into the crankshaft front cover and the other end is supported in the oil pump gear retaining plate.

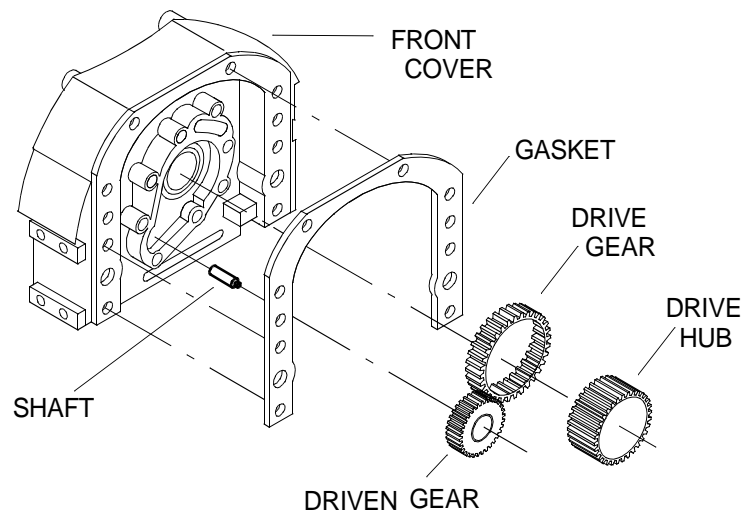

As the gears revolve, a vacuum is created on the inlet side of the pump and oil is drawn from the oil pan through the intake screen and pipe assembly into a passage in the crankshaft front cover, which leads to the inlet port in the pump. The oil then enters the cavities between the gears and the crankshaft front cover. It is then forced out under pressure through the discharge port into a short gallery in the cylinder block, which leads to the oil cooler block main oil gallery. At the same time, the oil is directed through a short vertical gallery to the pressure relief valve, which opens at approximately 105 PSI (724 kPa) to return excess oil to the oil pan.

Oil Pressure Regulator

Stabilized lubricating oil pressure is maintained within the engine at all speeds, regardless of the oil temperature, by an oil pressure regulator valve. The valve is installed at the end of the vertical oil gallery near the front of the cylinder block on the side opposite the oil cooler. The oil pressure regulator consists of a valve body, a hollow piston-type valve, a spring, a spring seat and a pin to retain the valve assembly within the valve body.

The valve is held on its seat by the spring, which is compressed by the pin in back of the spring seat. The entire assembly is bolted to the lower flange of the cylinder block and sealed against leaks by a gasket between the block and the valve body. When conditions are such that the oil pressure at the valve exceeds 50 PSI (345 kPa), the valve is forced from its seat and oil from the engine gallery is bypassed to the engine oil pan. Thus stabilized lubricating oil pressure is maintained at all times.

Under normal conditions, the oil pressure regulator should require very little attention. If sludge accumulates in the lubrication system, the valve may not work freely, thereby remaining open or failing to open at the normal operating pressure. Whenever the lubricating oil pump is removed for inspection, remove the regulator valve and spring and thoroughly clean and inspect them.

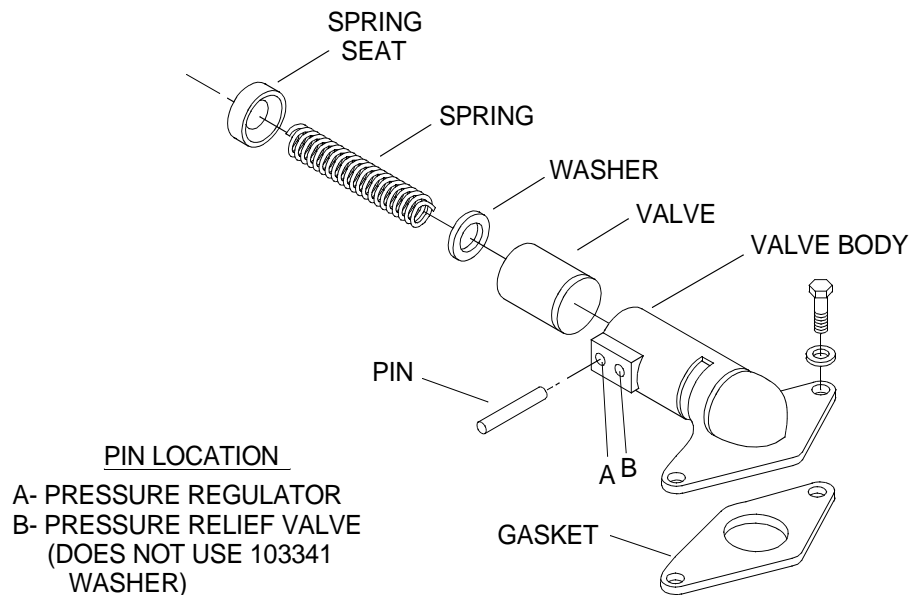

The Pressure Relief Valve

Oil leaving the pump under pressure passes into the pressure relief valve body. The spring-loaded valve opens when the pressure exceeds approximately 105 PSI (724 kPa) and directs the excess oil to the oil pan. The pressure relief valve is located at the lower end of the vertical oil gallery near the front of the cylinder block on the oil cooler side. The pressure relief valve consists of a valve body, a hollow piston-type valve, a spring, spring seat and a pin to retain the valve assembly within the valve body. The relief valve assembly used on the 8V engines is composed of the same parts as the regulator valve assembly. However, the retaining pin is located in the inner pin hole in the valve body to provide the necessary tension on the spring.

Service operations for the pressure relief valve are similar to those of the regulator valve. The spring in the 8V relief valve assemblies is the same as used in the oil pressure regulator assemblies. Replace the springs when they are pitted or fractured.

The Engine Oil Cooler

In order to perform its functions satisfactorily, the lubricating oil must be kept within the proper temperature limits. If the oil is too cold, it will not flow freely. If the oil is too hot, it cannot support the bearing loads, it cannot carry away enough heat and it may result in too great an oil flow. As a consequence, oil pressure may drop below acceptable limits and oil consumption may become excessive. In performing its lubricating and cooling functions, the oil absorbs a considerable amount of heat and this heat must be dissipated by an oil cooler. Each engine is provided with an oil cooler mounted on the right-hand side of the cylinder block at the lower front corner as viewed from the flywheel end of the engine. The 8V turbocharged engines are equipped with a 24 plate oil cooler. Oil from the lubricating oil pump flows through a passage in the oil cooler adaptor to the oil filter, then through the oil cooler, where it is cooled by

engine coolant and finally through the outlet passage in the cooler adaptor which leads to the cylinder block oil galleries. The engine coolant is pumped through the oil cooler and completely surrounds the oil cooler core. To ensure continuing engine lubrication should the oil cooler become plugged, a bypass valve is installed in the oil cooler adaptor.

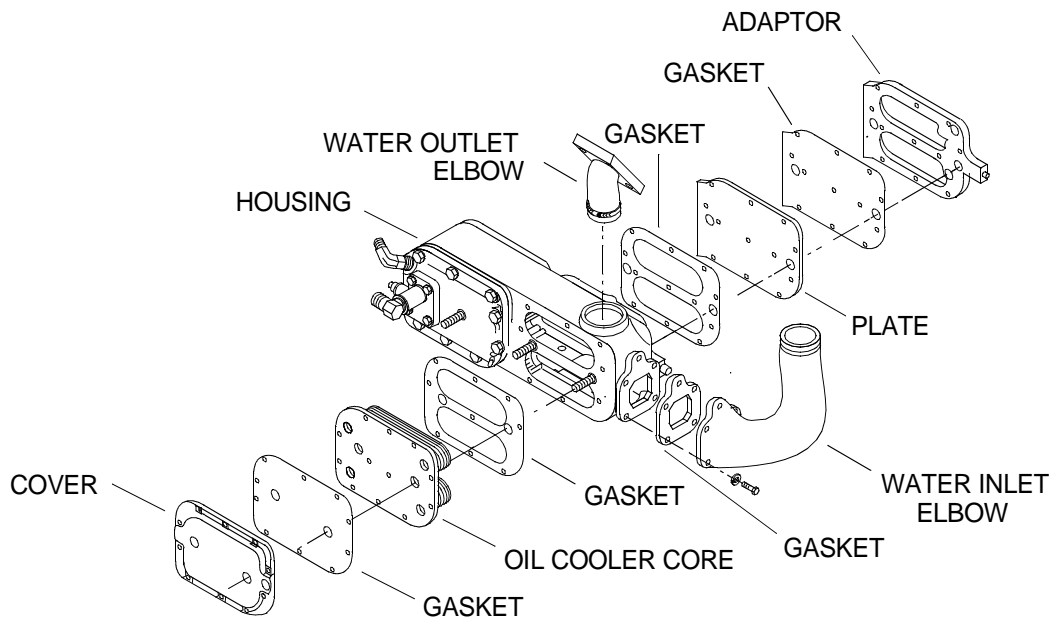

THE OIL DIPSTICK

A steel ribbon type oil level dipstick is used to check the quantity of oil in the engine oil pan. The dipstick is located in the side of the cylinder block or the oil pan. The engine includes a $\frac{3}{4}$ in. long rubber oil seal inside the cap of the dipstick. This prevents the escape of vapors carrying oil from the dipstick tube.

Maintain the oil level between the full and low marks on the dipstick and never allow it to drop below the low mark. No advantage is gained by having the oil level above the full mark. Overfilling will cause the oil to be churned by the crankshaft throws causing foaming or aeration of the oil. Operation below the low mark will expose the pump pick-up causing aeration and/or loss of pressure.

The Crankcase Ventilation System

Harmful vapors which may be formed within the engine are removed from the crankcase, gear train and valve compartment by a continuous pressurized ventilating system. Breathing is through two openings in the rear main bearing bulkhead of the crankcase and one large hole in the cylinder block rear end plate. They connect to a central chamber (separated from chambers on each side which carry oil draining back from the cylinder heads) that leads to an exit at the top of the cylinder block. The external tube(s) connects the cylinder block exit hole at the rear of the cylinder head(s). Failure to use a rocker cover breather on the left bank head can result in excessively high engine crankcase pressure. Excessive pressure can, in turn, cause crankshaft oil seal leakage and/or loss of oil through the dipstick tube. The rocker cover(s) provides a large cross-sectional air flow area at maximum height for efficient breathing and oil separation. A breather assembly is mounted at the openings in the rocker cover(s). To index the breather assembly exhaust outlet on the current aluminum die cast valve rocker covers, no disassembly is required. Insert a 1-1/8 in. (0.0286 M) outer diameter pipe or wood dowel into the exhaust outlet, apply pressure and rotate the outlet to the desired location.

THE EXHAUST SYSTEM

A water-cooled exhaust manifold is provided for engines incorporating a heat exchanger cooling system. The outlet flange may be located at the end or at the mid-section of the exhaust manifold, depending upon the installation requirements. A flexible exhaust connection or a muffler may be attached to the outlet flange. The exhaust manifold is attached to studs located between the exhaust ports and the outer side of the two end ports in the cylinder head. Special washers and nuts secure the manifold to the cylinder head.

The Water-Cooled Exhaust Manifold

The one-piece water-cooled manifold is cast with an integral water jacket surrounding the exhaust chamber. The diameter of the exhaust chamber increases uniformly from one end to the other where it terminates in a flange to which an elbow and flexible exhaust connection is attached. A portion of the engine coolant is bypassed from the rear of the cylinder block into the rear end of the jacket surrounding the exhaust manifold and is discharged from the forward end through a tube into the thermostat housing. A drain cock is installed in the bottom of the manifold for draining the water jacket. A plug is provided in the bottom of the exhaust manifold elbow for draining moisture condensed from the exhaust gases.

Water-Cooled Muffler

A normally open ball valve allows raw water exiting the marine gear oil cooler to be pumped into the exhaust system between the turbochargers and the muffler, filling the muffler with water and cooling prior to being expelled through the exhaust flapper port with the engine exhaust fumes. In addition to cooling the muffler, the water also acts as a noise dampening media within the muffler itself.

THE ELECTRICAL SYSTEM

The engine electrical system consists of a starting motor, a battery-charging alternator, a storage battery and the necessary wiring. Additional equipment such as an engine protective system is also included.

The Alternator

The battery-charging circuit consists of an alternator, battery and the wiring. The battery-charging alternator is introduced into the electrical system to provide a source of electrical current for maintaining the storage battery in a charged condition and to supply sufficient current to carry any other electrical load requirements up to the rated capacity of the alternator.

The hinge-mounted alternating current self-rectifying alternator, mounted on the front of the engine, is belt-driven. The alternator drive pulley is keyed to a shaft which is coupled to the end of the crankshaft. An adequate alternator drive ratio is necessary for an engine equipped with extra electrical accessories and one that has to operate for extended periods at idle speeds. Diodes, built into the slip ring end frame, rectify the three phase AC voltage to provide DC voltage at the battery terminal of the alternator, thereby eliminating the need for an external rectifier.

The Starting Motor

The starting motor is mounted on the flywheel housing. When the starting circuit is closed, a small drive pinion on the armature shaft engages with the teeth on the engine flywheel ring gear to crank the engine. When the engine starts, the drive pinion disengages to prevent the armature from overspeeding and damaging the starting motor.

The Overspeed Governor

The overspeed governor consists of four major components: the electronic speed switch, the air shutdown housing solenoid, the speed signal generator and the wiring harness.

The electronic speed switch controls the system by receiving a signal from the speed signal generator. If an overspeed condition is detected (2300 RPM or above), it will direct current to the air shutdown solenoid. This will close the air flapper which will shut down engine operation. The electronic speed switch will then have to be manually reset before the engine may be restarted.

CHAPTER 2

**UNIT, DIRECT SUPPORT AND GENERAL SUPPORT
TROUBLESHOOTING PROCEDURES
FOR
MODULAR CAUSEWAY SYSTEM (MCS)
CAUSEWAY FERRY (CF) ENGINE**

**UNIT, DIRECT SUPPORT AND GENERAL SUPPORT MAINTENANCE
CAUSEWAY FERRY
ENGINE
TROUBLESHOOTING PROCEDURES INDEX**

MALFUNCTION/SYMPTOM**TROUBLESHOOTING PROCEDURE****DIESEL ENGINE**

Above Normal Reading on Coolant Temperature Gauge	WP 0017 00
Below Normal Reading on Coolant Temperature Gauge	WP 0018 00
Does Not Start In Cold Temperatures	WP 0009 00
Excessive Reading on Oil Temperature Gauge	WP 0016 00
Fails To Stop When Emergency Stop is Activated	WP 0019 00
High Oil Consumption	WP 0014 00
Lacks Power	WP 0012 00
Low Oil Pressure	WP 0015 00
Noisy Operation or Vibration in Turbo Charger	WP 0020 00
Not Receiving Fuel From Fuel Tank	WP 0013 00
Starts With Difficulty And Runs Rough	WP 0010 00
Sudden Loss Of Power	WP 0011 00
Turns Over But Will Not Start	WP 0008 00
Will Not Turn Over	WP 0007 00

ELECTRICAL GENERATING SYSTEM

Generating System Shows Fully Charged Battery and/or High Charge Rate	WP 0022 00
Generating System Shows Low Battery and/or Low Charge Rate	WP 0021 00
Governor Actuator Goes to Full Stroke When Power is Applied and Engine Not Running	WP 0024 00
Governor Actuator Stays at Minimum Position When Power is Applied	WP 0023 00

**UNIT, DIRECT SUPPORT AND GENERAL SUPPORT MAINTENANCE
CAUSEWAY FERRY
DIESEL ENGINE
TROUBLESHOOTING PROCEDURES**

INITIAL SETUP:**Test Equipment**

Multimeter (Item 84, WP 0188 00)

Personnel Required

Engineer 88L

References

TM 55-1945-205-10-1

TM 55-1945-205-24-1-1

TM 9-6140-200-14

TROUBLESHOOTING PROCEDURE

ENGINE WILL NOT TURN OVER

NOTE

The following procedure is typical for both port and starboard engines.

SYMPTOM

Diesel engine will not turn over.

MALFUNCTION

MAIN circuit breaker A6CB1 is off.

CORRECTIVE ACTION

Position A6CB1 on propulsion module circuit breaker panel A6 to on.

Perform operational check of diesel engine. (TM 55-1945-205-10-1)

MALFUNCTION

ENGINE circuit breaker A6CB2 is off.

CORRECTIVE ACTION

Position A6CB2 on propulsion module circuit breaker panel A6 to on.

Perform operational check of diesel engine. (TM 55-1945-205-10-1)

MALFUNCTION

ENG POWER toggle switch 3A1S1/6 is off.

CORRECTIVE ACTION

Position 3A1S1/6 on middle control panel A1 to on.

Perform operational check of diesel engine. (TM 55-1945-205-10-1)

MALFUNCTION

Loose battery connections.

CORRECTIVE ACTION

Check battery connections and tighten if necessary. (TM 55-1945-205-24-1-1)

Perform operational check of diesel engine. (TM 55-1945-205-10-1)

MALFUNCTION

Loose starter connections.

CORRECTIVE ACTION

Check connections at starter and tighten if necessary. (TM 55-1945-205-24-1-1)

Perform operational check of diesel engine. (TM 55-1945-205-10-1)

MALFUNCTION

Low battery voltage.

CORRECTIVE ACTION

Recharge battery if ammeter on middle control panel A1 indicates low or no voltage.
(TM 9-6140-200-14)

MALFUNCTION

Defective ENG POWER toggle switch 3A1S1/6.

CORRECTIVE ACTION

Using multimeter, check for 24 VDC at 3A1S1/6. If not present, check continuity of wiring between ENG POWER toggle switch 3A1S1/6 and A6CB2 on propulsion module circuit breaker panel A6. If continuity is not present, repair/replace wiring as necessary.
(TM 55-1945-205-24-1-1)

Perform operational check of diesel engine. (TM 55-1945-205-10-1)

If voltage present, check voltage across switch. If not present, replace ENG POWER toggle switch 3A1S1/6 on middle control panel A1. (TM 55-1945-205-24-1-1)

Perform operational check of diesel engine. (TM 55-1945-205-10-1)

MALFUNCTION

Defective engine START push button 3A1S2/7.

CORRECTIVE ACTION

Using multimeter, check for 24 VDC at 3A1S2/7. If not present, check continuity of wiring between ENG POWER toggle switch 3A1S1/6 and START push button 3A1S1/6. If continuity is not present, repair/replace wiring as necessary. (TM 55-1945-205-24-1-1)

Perform operational check of diesel engine. (TM 55-1945-205-10-1)

If voltage is present, check voltage across push button. If not present, replace engine START push button 3A1S2/7 on middle control panel A1. (TM 55-1945-205-24-1-1)

Perform operational check of diesel engine. (TM 55-1945-205-10-1)

MALFUNCTION

Defective engine starter relay A1K1.

CORRECTIVE ACTION

Using multimeter, check for 24 VDC at A1K1. If not present, check continuity of wiring between engine START push button 3A1S1/6 and starter relay A1K1. If continuity is not present, repair/replace wiring as necessary. (TM 55-1945-205-24-1-1)

Perform operational check of diesel engine. (TM 55-1945-205-10-1)

If voltage is present, check voltage across relay. If not present, replace engine starter relay A1K1 on engine. (WP 0169 00)

Perform operational check of diesel engine. (TM 55-1945-205-10-1)

MALFUNCTION

Defective engine starter.

CORRECTIVE ACTION

Using multimeter, check for 24 VDC at starter. If not present, check continuity of wiring between engine starter relay A1K1 and starter. If continuity is not present, repair/replace wiring as necessary. (TM 55-1945-205-24-1-1)

Perform operational check of diesel engine. (TM 55-1945-205-10-1)

If voltage is present, replace starter motor. (WP 0170 00)

Perform operational check of diesel engine. (TM 55-1945-205-10-1)

MALFUNCTION

Internal engine seizure.

CORRECTIVE ACTION

Hand crank engine at least one complete revolution. If engine cannot be rotated, replace engine. (WP 0031 00)

Perform operational check of diesel engine. (TM 55-1945-205-10-1)

END OF WORK PACKAGE

**UNIT, DIRECT SUPPORT AND GENERAL SUPPORT MAINTENANCE
CAUSEWAY FERRY
DIESEL ENGINE
TROUBLESHOOTING PROCEDURE**

INITIAL SETUP:**Personnel Required**

Engineer 88L

References

TM 55-1945-205-10-1

TM 55-1945-205-24-1-1

TROUBLESHOOTING PROCEDURE

ENGINE TURNS OVER BUT WILL NOT START

NOTE

The following procedure is typical for both port and starboard engines.

SYMPTOM

Diesel engine turns over, but fails to start.

MALFUNCTION

No fuel in fuel tank.

CORRECTIVE ACTION

Fill fuel tank with fuel. (TM 55-1945-205-10-1)

Perform operational check of diesel engine. (TM 55-1945-205-10-1)

MALFUNCTION

Fuel shutoff valves are closed.

CORRECTIVE ACTION

Open fuel shutoff valves. (TM 55-1945-205-10-1)

Perform operational check of diesel engine. (TM 55-1945-205-10-1)

MALFUNCTION

Water in fuel water separator.

CORRECTIVE ACTION

Drain water via drain plug. (TM 55-1945-205-24-1-1)

Perform operational check of diesel engine. (TM 55-1945-205-10-1)

MALFUNCTION

Air in fuel system.

CORRECTIVE ACTION

Prime fuel system. (WP 0077 00)

Perform operational check of diesel engine. (TM 55-1945-205-10-1)

MALFUNCTION

Fuel has drained back and/or leaked out of supply lines.

CORRECTIVE ACTION

Replace leaking fuel lines as required. (WP 0080 00)

Use priming pump to restore fuel. (WP 0077 00)

Perform operational check of diesel engine. (TM 55-1945-205-10-1)

MALFUNCTION

Clogged or dirty fuel filter.

CORRECTIVE ACTION

Replace fuel filter cartridge. (WP 0079 00)

Perform operational check of diesel engine. (TM 55-1945-205-10-1)

MALFUNCTION

Insufficient fuel supply.

CORRECTIVE ACTION

Perform fuel flow test. (WP 0078 00)

Perform operational check of the diesel engine. (TM 55-1945-205-10-1)

MALFUNCTION

Fuel pump relief valve sticks open or partially open.

CORRECTIVE ACTION

Repair fuel pump. (WP 0095 00)

Perform operational check of the diesel engine. (TM 55-1945-205-10-1)

MALFUNCTION

Worn, damaged, corroded or dirty injectors.

CORRECTIVE ACTION

Perform injector cut out test. (WP 0078 00)

Perform operational check of the diesel engine. (TM 55-1945-205-10-1)

MALFUNCTION

Engine not getting enough air.

CORRECTIVE ACTION

Check air inlet collector air restriction indicators. If red button is visible, repair air inlet collector assembly. (WP 0105 00)

Perform operational check of diesel engine. (TM 55-1945-205-10-1)

Check that air flapper valve is open. If air flapper valve is closed, reset overspeed governor. (TM 55-1945-205-10-1)

Perform operational check of diesel engine. (TM 55-1945-205-10-1)

If air flapper remains closed, replace auto shutdown emergency stop solenoid. (WP 0176 00)

Perform operational check of diesel engine. (TM 55-1945-205-10-1)

MALFUNCTION

Blower not functioning.

CORRECTIVE ACTION

Check for broken drive shaft and replace as necessary. (WP 0109 00)

Perform operational check of diesel engine. (TM 55-1945-205-10-1)

Check blower for damage, repair blower as necessary. (WP 0111 00)

Perform operational check of diesel engine. (TM 55-1945-205-10-1)

MALFUNCTION

The emergency air shutdown was activated.

CORRECTIVE ACTION

Reset emergency air shutdown solenoid valve. (TM 55-1945-205-10-1)

Perform operational check of diesel engine. (TM 55-1945-205-10-1)

MALFUNCTION

Cold pack starting aid out of ether.

CORRECTIVE ACTION

Replace cold pack starting aid. (WP 0171 00)

Perform operational check of diesel engine. (TM 55-1945-205-10-1)

MALFUNCTION

Engine requires a tune-up.

CORRECTIVE ACTION

Perform engine tune-up. (WP 0028 00)

Perform operational check of diesel engine. (TM 55-1945-205-10-1)

MALFUNCTION

One or more damaged pistons and liners.

CORRECTIVE ACTION

Rebuild pistons and liners. (WP 0073 00)

Perform operational check of diesel engine. (TM 55-1945-205-10-1)

MALFUNCTION

Engine turning too slowly to start.

CORRECTIVE ACTION

Ensure marine gear is disengaged.

Perform operational check of diesel engine. (TM 55-1945-205-10-1)

Check battery output. If low, recharge or replace battery as necessary.
(TM 55-1945-205-10-1)

Perform operational check of diesel engine. (TM 55-1945-205-10-1)

Replace starter relay. (WP 0169 00)

Perform operational check of diesel engine. (TM 55-1945-205-10-1)

Replace starting motor. (WP 0170 00)

Perform operational check of diesel engine. (TM 55-1945-205-10-1)

END OF WORK PACKAGE

**UNIT, DIRECT SUPPORT AND GENERAL SUPPORT MAINTENANCE
CAUSEWAY FERRY
DIESEL ENGINE
TROUBLESHOOTING PROCEDURES**

INITIAL SETUP:**Personnel Required**

Engineer 88L

ReferencesTM 55-1945-205-10-1

TROUBLESHOOTING PROCEDURE

ENGINE DOES NOT START IN COLD TEMPERATURES

NOTE

The following procedure is typical for both port and starboard engines.

SYMPTOM

Diesel engine does not start in cold temperatures.

MALFUNCTION

Ether cylinder in cold pack starting aid is empty.

CORRECTIVE ACTION

Replace ether cylinder in cold pack starting aid. (WP 0171 00)

Perform operational check of diesel engine. (TM 55-1945-205-10-1)

END OF WORK PACKAGE

**UNIT, DIRECT SUPPORT AND GENERAL SUPPORT MAINTENANCE
CAUSEWAY FERRY
DIESEL ENGINE
TROUBLESHOOTING PROCEDURES**

INITIAL SETUP:**Personnel Required**

Engineer 88L

References

TM 55-1945-205-10-1

TM 55-1945-205-24-1-1

TROUBLESHOOTING PROCEDURE

ENGINE STARTS WITH DIFFICULTY AND RUNS ROUGH

NOTE

The following procedure is typical for both port and starboard engines.

SYMPTOM

Diesel engine starts with difficulty and runs rough.

MALFUNCTION

Faulty injector timing.

CORRECTIVE ACTION

Check injector timing. (WP 0092 00)

Perform operational check of diesel engine. (TM 55-1945-205-10-1)

Adjust injector rack control lever. (WP 0093 00)

Perform operational check of diesel engine. (TM 55-1945-205-10-1)

Perform engine tune-up. (WP 0028 00)

Perform operational check of diesel engine. (TM 55-1945-205-10-1)

MALFUNCTION

Clogged or damaged injectors.

CORRECTIVE ACTION

Clean clogged injectors. (WP 0091 00)

Perform operational check of diesel engine. (TM 55-1945-205-10-1)

Replace faulty injectors. (WP 0091 00)

Perform operational check of diesel engine. (TM 55-1945-205-10-1)

MALFUNCTION

Water is discovered in the fuel water separator.

CORRECTIVE ACTION

Drain water via the drain plug. (TM 55-1945-205-24-1-1)

Perform operational check of diesel engine. (TM 55-1945-205-10-1)

MALFUNCTION

The engine is not getting enough air.

CORRECTIVE ACTION

Check air inlet collector air restriction indicators for red bands. If visible, repair air inlet collector. (WP 0105 00)

Perform operational check of diesel engine. (TM 55-1945-205-10-1)

Check that air flapper valve is open. Open flapper valve if it is closed. (TM 55-1945-205-24-1-1)

Perform operational check of diesel engine. (TM 55-1945-205-10-1)

Check blower air intake for obstructions. Clean, repair or replace faulty parts. (WP 0103 00)

Perform operational check of diesel engine. (TM 55-1945-205-10-1)

Remove air box covers and inspect cylinder liner drain ports. Clean ports if they are over 50% plugged. (WP 0035 00)

Perform operational check of diesel engine. (TM 55-1945-205-10-1)

MALFUNCTION

Low coolant temperatures.

CORRECTIVE ACTION

Thermostat may not be closing. Test thermostats. (WP 0143 00)

Perform operational check of diesel engine. (TM 55-1945-205-10-1)

Coolant may be leaking past thermostat seals. Replace thermostat seals. (WP 0146 00)

Perform operational check of diesel engine. (TM 55-1945-205-10-1)

MALFUNCTION

Low compression.

CORRECTIVE ACTION

Perform engine compression test. (WP 0030 00)

Perform operational check of diesel engine. (TM 55-1945-205-10-1)

Remove air box covers and inspect compression rings through ports in the cylinder liners. (WP 0035 00)

Perform operational check of diesel engine. (TM 55-1945-205-10-1)

Rebuild cylinder and liner assemblies if rings are badly worn or broken. (WP 0051 00)

Perform operational check of diesel engine. (TM 55-1945-205-10-1)

Repair cylinder head exhaust valves. (WP 0055 00)

Perform operational check of diesel engine. (TM 55-1945-205-10-1)

Verify blower is functioning. Repair as necessary. (WP 0111 00)

Perform operational check of diesel engine. (TM 55-1945-205-10-1)

Verify blower bypass valve is not stuck open. Replace as necessary. (WP 0108 00)

Perform operational check of diesel engine. (TM 55-1945-205-10-1)

END OF WORK PACKAGE

**UNIT, DIRECT SUPPORT AND GENERAL SUPPORT MAINTENANCE
CAUSEWAY FERRY
DIESEL ENGINE
TROUBLESHOOTING PROCEDURES**

INITIAL SETUP:**Personnel Required**

Engineer 88L

References

TM 55-1945-205-10-1

TM 55-1945-205-24-1-1

TROUBLESHOOTING PROCEDURE**SUDDEN LOSS OF POWER****NOTE**

The following procedure is typical for both port and starboard engines.

SYMPTOM

Power from the diesel engine is lost, but no black smoke is coming from the exhaust plenum.

MALFUNCTION

Water in the fuel water separator.

CORRECTIVE ACTION

Drain off water via the drain plug. (TM 55-1945-205-24-1-1)

Perform operational check of diesel engine. (TM 55-1945-205-10-1)

MALFUNCTION

Fuel shutoff valves are closed.

CORRECTIVE ACTION

Open the fuel shutoff valves. (TM 55-1945-205-24-1-1)

Perform operational check of diesel engine. (TM 55-1945-205-10-1)

MALFUNCTION

Fuel filter contains contamination.

CORRECTIVE ACTION

Replace the fuel system filter. (WP 0079 00)

Perform operational check of diesel engine. (TM 55-1945-205-10-1)

SYMPTOM

Power from the diesel engine is lost and heavy black smoke is coming from the exhaust plenum.

MALFUNCTION

The air inlet is blocked.

CORRECTIVE ACTION

Remove the blockage from the air inlet. (WP 0105 00)

Perform operational check of diesel engine. (TM 55-1945-205-10-1)

MALFUNCTION

The fuel return line shutoff valve is not open.

CORRECTIVE ACTION

Open the return line fuel valve. (TM 55-1945-205-10-1)

Perform operational check of diesel engine. (TM 55-1945-205-10-1)

MALFUNCTION

The air inlet collector air restriction indicator red band is visible.

CORRECTIVE ACTION

Repair air inlet collector assembly. (WP 0105 00)

Perform operational check of diesel engine. (TM 55-1945-205-10-1)

END OF WORK PACKAGE

**UNIT, DIRECT SUPPORT AND GENERAL SUPPORT MAINTENANCE
CAUSEWAY FERRY
DIESEL ENGINE
TROUBLESHOOTING PROCEDURES**

INITIAL SETUP:**Personnel Required**

Engineer 88L

References

TM 55-1945-205-10-1

TM 55-1945-205-24-1-1

TROUBLESHOOTING PROCEDURE

ENGINE LACKS POWER

NOTE

The following procedure is typical for both port and starboard engines.

SYMPTOM

Diesel engine will not deliver rated power.

MALFUNCTION

Improper engine adjustments and gear train timing.

CORRECTIVE ACTION

Check engine gear train timing. Replace gears as necessary. (WP 0064 00)

Perform operational check of diesel engine. (TM 55-1945-205-10-1)

MALFUNCTION

Insufficient fuel.

CORRECTIVE ACTION

Perform fuel flow test. (WP 0078 00)

Perform operational check of diesel engine. (TM 55-1945-205-10-1)

MALFUNCTION

Leaking injector spray tips.

CORRECTIVE ACTION

Replace faulty injectors. (WP 0091 00)

Perform operational check of diesel engine. (TM 55-1945-205-10-1)

MALFUNCTION

The engine is not getting enough air.

CORRECTIVE ACTION

Check air inlet collector for visible red air restriction indicator band. Repair air inlet collectors. (WP 0105 00)

Perform operational check of diesel engine. (TM 55-1945-205-10-1)

Check that air flapper valve is open. If it is not, open it. (TM 55-1945-205-10-1)

Perform operational check of diesel engine. (TM 55-1945-205-10-1)

Check blower air intake for obstructions. Repair air inlet housing. (WP 0103 00)

Perform operational check of diesel engine. (TM 55-1945-205-10-1)

Remove air box covers and inspect cylinder liner ports. Clean ports if they are over 50% plugged. (WP 0036 00)

Perform operational check of diesel engine. (TM 55-1945-205-10-1)

MALFUNCTION

High return fuel temperature.

CORRECTIVE ACTION

Perform fuel spill-back temperature test. (WP 0078 00)

Perform operational check of diesel engine. (TM 55-1945-205-10-1)

MALFUNCTION

High ambient air temperature.

CORRECTIVE ACTION

Check ambient air temperature. Once air temperature is above 90°, there is a 2% loss of horsepower for every 20° increase in fuel temperature.

Perform operational check of diesel engine. (TM 55-1945-205-10-1)

MALFUNCTION

Blower bypass valve is stuck open.

CORRECTIVE ACTION

Check blower bypass valve to determine if it is stuck open. Inspect for scoring of valve piston or piston guide. Replace valve assembly if any of above conditions are noted.
(WP 0108 00)

Perform operational check of diesel engine. (TM 55-1945-205-10-1)

END OF WORK PACKAGE

**UNIT, DIRECT SUPPORT AND GENERAL SUPPORT MAINTENANCE
CAUSEWAY FERRY
DIESEL ENGINE
TROUBLESHOOTING PROCEDURES**

INITIAL SETUP:**Personnel Required**

Engineer 88L

References

TM 55-1945-205-10-1

TM 55-1945-205-24-1-1

TROUBLESHOOTING PROCEDURE

NOT RECEIVING FUEL FROM TANK

NOTE

The following procedure is typical the both port and starboard engines.

SYMPTOM

The diesel engine is not receiving fuel from tank.

MALFUNCTION

Low fuel or no fuel in the fuel tank.

CORRECTIVE ACTION

Fill the fuel tank with fuel. (TM 55-1945-205-10-1)

Perform operational check of diesel engine. (TM 55-1945-205-10-1)

MALFUNCTION

The fuel shutoff valves are closed.

CORRECTIVE ACTION

Open the fuel shutoff valves. (TM 55-1945-205-10-1)

Perform operational check of diesel engine. (TM 55-1945-205-10-1)

MALFUNCTION

Fuel has drained back and/or leaked out of supply lines.

CORRECTIVE ACTION

Replace fuel lines. (WP 0080 00)

Perform operational check of diesel engine. (TM 55-1945-205-10-1)

Prime fuel system. (WP 0077 00)

Perform operational check of diesel engine. (TM 55-1945-205-10-1)

MALFUNCTION

Loose connections or cracked fuel lines.

CORRECTIVE ACTION

Perform a fuel flow test. (WP 0078 00)

Perform operational check of diesel engine. (TM 55-1945-205-10-1)

If air is present, tighten loose connections and replace cracked fuel lines. (WP 0080 00)

Perform operational check of diesel engine. (TM 55-1945-205-10-1)

MALFUNCTION

Damaged fuel oil strainer gasket.

CORRECTIVE ACTION

Perform a fuel flow test. (WP 0078 00)

Perform operational check of diesel engine. (TM 55-1945-205-10-1)

If air is present, replace the fuel strainer gasket when changing the strainer element.
(TM 55-1945-205-24-1-1)

Perform operational check of diesel engine. (TM 55-1945-205-10-1)

MALFUNCTION

Fuel flow restricted in fuel strainer or fuel lines.

CORRECTIVE ACTION

Locate and remove restriction.

Perform a fuel flow test. (WP 0078 00)

Perform operational check of diesel engine. (TM 55-1945-205-10-1)

Replace fuel strainer. (TM 55-1945-205-24-1-1)

Perform operational check of diesel engine. (TM 55-1945-205-10-1)

Replace filter elements. (WP 0079 00)

Perform operational check of diesel engine. (TM 55-1945-205-10-1)

Replace fuel lines, as necessary. (WP 0080 00)

Perform operational check of diesel engine. (TM 55-1945-205-10-1)

SYMPTOM

Power from the diesel engine is lost and heavy black smoke is coming from the exhaust plenum.

MALFUNCTION

The fuel tank vents are blocked.

CORRECTIVE ACTION

Remove the blockage from the fuel tank vents. (TM 55-1945-205-24-1-1)

Perform operational check of diesel engine. (TM 55-1945-205-10-1)

MALFUNCTION

Worn gears or pump body.

CORRECTIVE ACTION

Repair fuel pump. (WP 0095 00)

Perform operational check of diesel engine. (TM 55-1945-205-10-1)

MALFUNCTION

Relief valve not seating.

CORRECTIVE ACTION

Perform a fuel flow test. (WP 0078 00)

Perform operational check of diesel engine. (TM 55-1945-205-10-1)

If fuel flow is inadequate, clean and inspect the relief valve seat assembly. (WP 0095 00)

Perform operational check of diesel engine. (TM 55-1945-205-10-1)

END OF WORK PACKAGE

**UNIT, DIRECT SUPPORT AND GENERAL SUPPORT MAINTENANCE
CAUSEWAY FERRY
DIESEL ENGINE
TROUBLESHOOTING PROCEDURES**

INITIAL SETUP:**Personnel Required**

Engineer 88L

References

TM 55-1945-205-10-1

TM 55-1945-205-24-1-1

TROUBLESHOOTING PROCEDURE**HIGH OIL CONSUMPTION****NOTE**

The following procedure is typical for both port and starboard engines.

SYMPTOM

Diesel engine has high oil consumption due to external leaks.

MALFUNCTION

Oil lines or connections leaking.

CORRECTIVE ACTION

Tighten any loose connections or replace any oil lines that are cracked or broken.
(WP 0118 00)

Perform operational check of diesel engine. (TM 55-1945-205-10-1)

MALFUNCTION

Gaskets or oil seals leaking.

CORRECTIVE ACTION

Steam clean engine and run at no-load RPM to reveal leaking gaskets or oil seals.

Repair oil leaks by replacing necessary gaskets and seals.

Perform operational check of diesel engine. (TM 55-1945-205-10-1)

MALFUNCTION

Overfilled crankcase.

CORRECTIVE ACTION

Check dipstick for proper oil level. Service crankcase oil. (WP 0115 00)

Perform operational check of diesel engine. (TM 55-1945-205-10-1)

MALFUNCTION

Plugged breathers.

CORRECTIVE ACTION

Clean engine breathers. (TM 55-1945-205-24-1-1)

After cleaning, check crankcase pressure. (WP 0116 00)

MALFUNCTION

Excessive crankcase pressure.

CORRECTIVE ACTION

See electrical generating system troubleshooting procedure. (WP 0016 00)

Perform operational check of diesel engine. (TM 55-1945-205-10-1)

SYMPTOM

Diesel engine has high oil consumption due to internal leaks.

MALFUNCTION

Blower oil seals are leaking.

CORRECTIVE ACTION

To reveal blower oil seal leaks, expose blower end plates by removing piping from air inlet housing and from blower. (WP 0103 00) Operate engine at idle. Inspect end plates for evidence of leaking, using flashlight if necessary.

If oil leakage is present on end plates. Repair blower. (WP 0111 00)

Perform operational check of diesel engine. (TM 55-1945-205-10-1)

MALFUNCTION

Turbocharger seals are leaking.

CORRECTIVE ACTION

To confirm a leaking oil seal, remove the compressor housing (WP 0114 00) and inspect the backplate. If the surface is wet with oil, it indicates leakage. Replace turbocharger. (WP 0114 00)

Perform operational check of diesel engine. (TM 55-1945-205-10-1)

MALFUNCTION

Oil cooler core leaking.

CORRECTIVE ACTION

Repair oil cooler. (WP 0128 00)

Perform operational check of diesel engine. (TM 55-1945-205-10-1)

MALFUNCTION

Worn exhaust valve guides.

CORRECTIVE ACTION

Replace worn exhaust valve guides. (WP 0058 00)

Perform operational check of diesel engine. (TM 55-1945-205-10-1)

SYMPTOM

Diesel engine has high oil consumption.

MALFUNCTION

Low compression.

CORRECTIVE ACTION

Perform compression test. (WP 0030 00) A compression check with low readings indicates worn out cylinders. Rebuild pistons and liners. (WP 0073 00)

Perform operational check of diesel engine. (TM 55-1945-205-10-1)

MALFUNCTION

Piston pin retainer loose.

CORRECTIVE ACTION

To determine if uncontrolled oil is in air box, remove air box covers (WP 0036 00). Run engine at idle speed. Check for excess oil slobbering from cylinder liner ports. Inspect all cylinders as more than one may be slobbering. Rebuild pistons and liners. (WP 0073 00)

Perform operational check of diesel engine. (TM 55-1945-205-10-1)

MALFUNCTION

Worn oil control rings broken, scored or improperly installed.

CORRECTIVE ACTION

Rebuild pistons and liners. (WP 0073 00)

Perform operational check of diesel engine (TM 55-1945-205-10-1)

MALFUNCTION

Excessive oil in air box

CORRECTIVE ACTION

To determine if there is excessive oil in air box, remove air box covers (WP 0036 00). Run engine at idle speed. Check for excess oil slobbering from cylinder liner ports. Inspect all cylinders as more than one may be slobbering. Rebuild pistons and liners. (WP 0073 00)

Perform operational check of diesel engine. (TM 55-1945-205-10-1)

Check for leakage from blower oil seals. Remove piping from inlet housing and from blower. Operate engine at idle. Inspect blower end plates for oil leakage. Use a flashlight to illuminate if necessary. If oil leakage is present, repair the blower. (WP 0111 00)

Perform operational check of diesel engine. (TM 55-1945-205-10-1)

Check for leaking oil seal on turbocharger and replace turbocharger as necessary. (WP 0114 00)

Perform operational check of diesel engine. (TM 55-1945-205-10-1)

To confirm a leaking oil seal, check for oil residue on compressor and on turbine sides of the turbocharger. Remove compressor housing, if applicable, and inspect the backplate. If the surface is wet with oil, seal is leaking. Replace turbocharger. (WP 0114 00)

Perform operational check of diesel engine. (TM 55-1945-205-10-1)

MALFUNCTION

Dirt in air intake system.

CORRECTIVE ACTION

Check for faulty air induction system that allows contaminated air to enter engine. Dust and dirt entering engine will cause rapid wear of piston rings, cylinder liners, pistons and exhaust valve mechanism. Perform compression test. (WP 0030 00) A compression test with excessively low readings will indicate worn out cylinders. Rebuild pistons and liners. (WP 0073 00)

Perform operational check of diesel engine. (TM 55-1945-205-10-1)

END OF WORK PACKAGE

**UNIT, DIRECT SUPPORT AND GENERAL SUPPORT MAINTENANCE
CAUSEWAY FERRY
DIESEL ENGINE
TROUBLESHOOTING PROCEDURES**

INITIAL SETUP:**Personnel Required**

Engineer 88L

References

TM 55-1945-205-10-1

TM 55-1945-205-24-1-1

TROUBLESHOOTING PROCEDURE

LOW READING ON OIL PRESSURE GAGE

NOTE

The following procedure is typical for both port and starboard engines.

Check oil pressure with the engine warmed up and a minimum water outlet temperature of 160°F (71°C).

SYMPTOM

Diesel engine has low oil pressure.

MALFUNCTION

Engine oil low.

CORRECTIVE ACTION

Check oil and bring to proper level on the dipstick. (WP 0115 00)

Perform operational check of diesel engine. (TM 55-1945-205-10-1)

MALFUNCTION

Improper oil viscosity.

CORRECTIVE ACTION

Submit oil sample to AOAP for viscosity verification. (DA PAM 738-750)

If instructed by AOAP lab, service oil lube system. (WP 0115 00)

Perform operational check of diesel engine. (TM 55-1945-205-10-1)

MALFUNCTION

Poor circulation, oil cooler clogged.

CORRECTIVE ACTION

Remove, clean inspect and install the oil cooler. (WP 0128 00)

Perform operational check of diesel engine. (TM 55-1945-205-10-1)

MALFUNCTION

Oil cooler bypass sticking open.

CORRECTIVE ACTION

Remove the oil cooler bypass valve. Clean the valve and valve seat. Inspect the valve spring. Replace defective parts. (WP 0129 00)

Perform operational check of diesel engine. (TM 55-1945-205-10-1)

MALFUNCTION

Pressure regulator sticking open.

CORRECTIVE ACTION

Repair the pressure regulator valve. (WP 0124 00)

Perform operational check of diesel engine. (TM 55-1945-205-10-1)

MALFUNCTION

Excessive wear on crankshaft bearings.

CORRECTIVE ACTION

Replace crankshaft and bearings as a set. (WP 0060 00)

Perform operational check of diesel engine. (TM 55-1945-205-10-1)

MALFUNCTION

Faulty oil pressure gauge.

CORRECTIVE ACTION

Replace oil pressure gauge. (TM 55-1945-205-24-1-1)

Perform operational check of diesel engine. (TM 55-1945-205-10-1)

MALFUNCTION

Electrical instrument panel sending units are faulty.

CORRECTIVE ACTION

Replace defective electrical equipment. (TM 55-1945-205-24-1-1)

Perform operational check of diesel engine. (TM 55-1945-205-10-1)

MALFUNCTION

Oil pump screen partially clogged.

CORRECTIVE ACTION

Remove and clean oil pump screen. (WP 0121 00)

Perform operational check of diesel engine. (TM 55-1945-205-10-1)

Change oil filter. (TM 55-1945-205-24-1-1)

Perform operational check of diesel engine. (TM 55-1945-205-10-1)

MALFUNCTION

Oil pressure relief valve sticking open.

CORRECTIVE ACTION

Repair oil pressure relief valve. (WP 0126 00)

Perform operational check of diesel engine. (TM 55-1945-205-10-1)

MALFUNCTION

Air leak in oil pump suction.

CORRECTIVE ACTION

Disassemble the piping and install new gaskets. (WP 0122 00)

Perform operational check of diesel engine. (TM 55-1945-205-10-1)

MALFUNCTION

Oil pump worn or damaged.

CORRECTIVE ACTION

Remove oil pump. Repair or replace defective parts. (WP 0120 00)

Perform operational check of diesel engine. (TM 55-1945-205-10-1)

END OF WORK PACKAGE

**UNIT, DIRECT SUPPORT AND GENERAL SUPPORT MAINTENANCE
CAUSEWAY FERRY
DIESEL ENGINE
TROUBLESHOOTING PROCEDURE**

INITIAL SETUP:**Personnel Required**

Engineer 88L

References

TM 55-1945-205-10-1

TM 55-1945-205-24-1-1

TROUBLESHOOTING PROCEDURE

EXCESSIVE READING ON OIL PRESSURE GAGE

NOTE

The following procedure is typical for both port and starboard engines.

SYMPTOM

Diesel engine has excessive crankcase pressure.

MALFUNCTION

Cylinder head gasket leaking.

CORRECTIVE ACTION

Check cylinder compression. (WP 0030 00)

Perform operational check of diesel engine. (TM 55-1945-205-10-1)

If only one cylinder has low compression, remove the cylinder head and replace the head gaskets. (WP 0046 00)

Perform operational check of diesel engine. (TM 55-1945-205-10-1)

MALFUNCTION

Cylinder blow-by, piston or liner damaged.

CORRECTIVE ACTION

Inspect piston and liner. Replace damaged parts. (WP 0073 00)

Perform operational check of diesel engine. (TM 55-1945-205-10-1)

MALFUNCTION

Cylinder blow-by, piston rings worn or broken.

CORRECTIVE ACTION

Install new piston rings. (WP 0073 00)

Perform operational check of diesel engine. (TM 55-1945-205-10-1)

MALFUNCTION

Obstruction or damage to breather.

CORRECTIVE ACTION

Clean, repair or replace breather assembly as necessary. (WP 0044 00)

Perform operational check of diesel engine. (TM 55-1945-205-10-1)

MALFUNCTION

Damaged blower-to-block gasket.

CORRECTIVE ACTION

Replace the blower-to-block gasket. (WP 0110 00)

Perform operational check of diesel engine. (TM 55-1945-205-10-1)

MALFUNCTION

Leakage at cylinder block end plate gaskets.

CORRECTIVE ACTION

Replace end plate gaskets as necessary. (WP 0038 00, WP 0040 00)

Perform operational check of diesel engine. (TM 55-1945-205-10-1)

MALFUNCTION

Excessive exhaust back pressure, high muffler resistance.

CORRECTIVE ACTION

Check exhaust back pressure and repair or replace muffler. (TM 55-1945-205-24-1-1)

Perform operational check of diesel engine. (TM 55-1945-205-10-1)

MALFUNCTION

Faulty exhaust piping.

CORRECTIVE ACTION

Check exhaust back pressure. Install larger piping. (TM 55-1945-205-24-1-1)

Perform operational check of diesel engine. (TM 55-1945-205-10-1)

MALFUNCTION

Lube oil pressure regulator valve sticking closed.

CORRECTIVE ACTION

Repair lube oil pressure regulator valve. (WP 0124 00)

MALFUNCTION

Lube oil pressure relief valve sticking closed.

CORRECTIVE ACTION

Repair lube oil pressure relief valve. (WP 0126 00)

MALFUNCTION

Lube oil cooler by-pass valve sticking closed when lube oil cooler is clogged.

CORRECTIVE ACTION

Repair lube oil cooler by-pass valve. (WP 0129 00)

MALFUNCTION

Lube oil filter by-pass valve sticking closed when oil filters are clogged.

CORRECTIVE ACTION

Repair oil filter by-pass valve. (TM 55-1945-205-24-1-1)

MALFUNCTION

Excessive sludge in lube oil system.

CORRECTIVE ACTION

Repair engine block. (WP 0042 00)

END OF WORK PACKAGE

**UNIT, DIRECT SUPPORT AND GENERAL SUPPORT MAINTENANCE
CAUSEWAY FERRY
DIESEL ENGINE
TROUBLESHOOTING PROCEDURES**

INITIAL SETUP:**Personnel Required**

Engineer 88L

References

TM 55-1945-205-10-1

TM 55-1945-205-24-1-1

TROUBLESHOOTING PROCEDURE

ABOVE NORMAL READING ON ENGINE COOLANT TEMPERATURE GAGE

NOTE

The following procedure is typical for both port and starboard engines.

Check oil pressure with the engine warmed up and a minimum water outlet temperature of 160°F (71°C).

SYMPTOM

Diesel engine has above normal engine coolant operating temperature.

MALFUNCTION

Insufficient heat transfer.

CORRECTIVE ACTION

Clean cooling system and heat exchanger with cooling system cleaner. Thoroughly flush system to remove scale deposits. (WP 0134 00)

Perform operational check of diesel engine. (TM 55-1945-205-10-1)

MALFUNCTION

Faulty water pump.

CORRECTIVE ACTION

Repair water pump. (WP 0154 00)

MALFUNCTION

Faulty thermostat.

CORRECTIVE ACTION

Replace thermostat. (WP 0143 00)

MALFUNCTION

Fuel-air mixture too lean.

CORRECTIVE ACTION

Perform engine tune-up. (WP 0028 00)

MALFUNCTION

Exhaust plenum fan not operating.

CORRECTIVE ACTION

Replace exhaust plenum fan. (TM 55-1945-205-24-1-1)

MALFUNCTION

Poor circulation.

CORRECTIVE ACTION

Check coolant level in fresh water cooling system and fill to correct level if coolant level is low. (WP 0133 00)

Perform operational check of diesel engine. (TM 55-1945-205-10-1)

Inspect cooling system for collapsed or disintegrated hoses. Replace defective hoses. (WP 0149 00)

Perform operational check of diesel engine. (TM 55-1945-205-10-1)

Inspect raw water strainer basket for debris. Clean or replace as needed. (TM 55-1945-205-24-1-1)

Perform operational check of diesel engine. (TM 55-1945-205-10-1)

Check for combustion gases in cooling system by removing coolant filler cap and operating engine. If gases are present, remove cylinder head and inspect for cracks. Repair or replace cylinder head. Replace head gaskets. (WP 0046 00)

Perform operational check of diesel engine. (TM 55-1945-205-10-1)

Check for air leak on suction side of water pump. (WP 0136 00) Replace defective parts. (WP 0149 00)

Perform operational check of diesel engine. (TM 55-1945-205-10-1)

END OF WORK PACKAGE

**UNIT, DIRECT SUPPORT AND GENERAL SUPPORT MAINTENANCE
CAUSEWAY FERRY
DIESEL ENGINE
TROUBLESHOOTING PROCEDURES**

INITIAL SETUP:**Personnel Required**

Engineer 88L

References

TM 55-1945-205-10-1

TM 55-1945-205-24-1-1

TROUBLESHOOTING PROCEDURE

BELOW NORMAL READING ON ENGINE COOLANT TEMPERATURE GAGE

NOTE

The following procedure is typical for both port and starboard engines.

Check oil pressure with the engine warmed up and a minimum water outlet temperature of 160°F (71°C).

SYMPTOM

Diesel engine has below normal engine coolant operating temperature.

MALFUNCTION

Improper circulation.

CORRECTIVE ACTION

Remove, inspect and test thermostat. (WP 0146 00)

Install new thermostat if necessary. (WP 0143 00)

Perform operational check of diesel engine. (TM 55-1945-205-10-1)

Check heater hoses installed correctly. (TM 55-1945-205-24-1-1)

Perform operational check of diesel engine. (TM 55-1945-205-10-1)

Replace the thermostat seals. (WP 0143 00)

Perform operational check of diesel engine. (TM 55-1945-205-10-1)

END OF WORK PACKAGE

**UNIT, DIRECT SUPPORT AND GENERAL SUPPORT MAINTENANCE
CAUSEWAY FERRY
DIESEL ENGINE
TROUBLESHOOTING PROCEDURES**

INITIAL SETUP:**Test Equipment**

Multimeter (Item 84, WP 0188 00)

Personnel Required

Engineer 88L

References

TM 55-1945-205-10-1

TM 55-1945-205-24-1-1

TROUBLESHOOTING PROCEDURE

ENGINE FAILS TO STOP WHEN EMERGENCY STOP IS ACTIVATED

NOTE

The following procedure is typical for both port and starboard engines.

SYMPTOM

Emergency stop solenoid fails to stop diesel engine.

MALFUNCTION

Short circuit between solenoid and stop button on engine junction box A4.

CORRECTIVE ACTION

Using a multimeter, check for continuity between solenoid and stop button on engine junction box A4. If continuity is not present, repair replace wiring as necessary. (TM 55-1945-205-24-1-1)

Perform operational check of emergency stop solenoid. (TM 55-1945-205-10-1)

MALFUNCTION

Loose connection on solenoid.

CORRECTIVE ACTION

Check connections and tighten, as necessary. (TM 55-1945-205-24-1-1)

Perform operational check of emergency stop solenoid. (TM 55-1945-205-10-1)

MALFUNCTION

Emergency stop solenoid is defective.

CORRECTIVE ACTION

Replace emergency stop solenoid. (WP 0176 00)

Perform operational check of emergency stop solenoid. (TM 55-1945-205-10-1)

MALFUNCTION

Emergency stop relay is defective.

CORRECTIVE ACTION

Replace emergency stop relay. (TM 55-1945-205-24-1-1)

Perform operational check of emergency stop solenoid. (TM 55-1945-205-10-1)

MALFUNCTION

Fuel oil pressure sending unit is defective.

CORRECTIVE ACTION

Replace defective fuel oil pressure sending unit. (WP 0179 00)

Perform operational check of emergency stop solenoid. (TM 55-1945-205-10-1)

MALFUNCTION

Oil pressure sending unit is defective.

CORRECTIVE ACTION

Replace defective oil pressure sending unit. (WP 0178 00)

Perform operational check of emergency stop solenoid. (TM 55-1945-205-10-1)

MALFUNCTION

Water temperature sending unit is defective.

CORRECTIVE ACTION

Replace defective water temperature sending unit. (WP 0177 00)

Perform operational check of emergency stop solenoid. (TM 55-1945-205-10-1)

MALFUNCTION

Fuel return line is clogged.

CORRECTIVE ACTION

Replace fuel line. (WP 0080 00)

Perform operational check of emergency stop solenoid. (TM 55-1945-205-10-1)

MALFUNCTION

Shutoff valve closed.

CORRECTIVE ACTION

Open shutoff valve. (TM 55-1945-205-10-1)

END OF WORK PACKAGE

**UNIT, DIRECT SUPPORT AND GENERAL SUPPORT MAINTENANCE
CAUSEWAY FERRY
DIESEL ENGINE
TROUBLESHOOTING PROCEDURES**

INITIAL SETUP:**Personnel Required**

Engineer 88L

ReferencesTM 55-1945-205-10-1

TROUBLESHOOTING PROCEDURE

NOISY OPERATION OR VIBRATION IN TURBOCHARGER

NOTE

The following procedure is typical for both port and starboard engines.

SYMPTOM

Noisy operation or vibration in turbocharger.

MALFUNCTION

Wheel shaft bearings are not being lubricated.

CORRECTIVE ACTION

Determine cause of loss of oil pressure and repair.

Replace turbocharger if necessary. (WP 0114 00)

Perform operational check of the turbocharger. (TM 55-1945-205-10-1)

MALFUNCTION

Turbocharger bearings unserviceable.

CORRECTIVE ACTION

Replace turbocharger. (WP 0114 00)

Perform operational check of the turbocharger. (TM 55-1945-205-10-1)

MALFUNCTION

Leak in engine air intake piping and housing.

CORRECTIVE ACTIONTighten all loose connections. Replace air intake housing gaskets as necessary.
(WP 0103 00)

Perform operational check of the turbocharger. (TM 55-1945-205-10-1)

MALFUNCTION

Leak in engine exhaust manifold.

CORRECTIVE ACTION

Tighten all loose connections. Replace exhaust manifold gaskets as necessary.
(WP 0163 00)

Perform operational check of the turbocharger. (TM 55-1945-205-10-1)

END OF WORK PACKAGE

**UNIT, DIRECT SUPPORT AND GENERAL SUPPORT MAINTENANCE
CAUSEWAY FERRY
DIESEL ENGINE
TROUBLESHOOTING PROCEDURES**

INITIAL SETUP:**Personnel Required**

Engineer 88L

References

TM 55-1945-205-10-1

TM 55-1945-205-24-1-1

TROUBLESHOOTING PROCEDURE

ELECTRICAL GENERATING SYSTEM SHOWS LOW BATTERY AND LOW OR NO CHARGING RATE

NOTE

The following procedure is typical for both port and starboard engines.

SYMPTOM

Electrical generating system shows low battery and low or no charging rate.

MALFUNCTION

Loose connections or damaged wiring.

CORRECTIVE ACTIONCheck all connections and inspect for damaged wiring. Repair or replace as necessary.
(TM 55-1945-205-24-1-1)

Perform operational check of the charging system. (TM 55-1945-205-10-1)

MALFUNCTION

Defective battery.

CORRECTIVE ACTION

Test battery. (TM 55-1945-205-24-1-1)

Replace battery, as necessary. (TM 55-1945-205-24-1-1)

Perform operational check of the charging system. (TM 55-1945-205-10-1)

MALFUNCTION

Defective alternator.

CORRECTIVE ACTION

Replace alternator. (TM 55-1945-205-24-1-1)

Perform operational check of the charging system. (TM 55-1945-205-10-1)

MALFUNCTION

Defective regulator.

CORRECTIVE ACTION

Replace regulator. (TM 55-1945-205-24-1-1)

Perform operational check of the charging system. (TM 55-1945-205-10-1)

END OF WORK PACKAGE

**UNIT, DIRECT SUPPORT AND GENERAL SUPPORT MAINTENANCE
CAUSEWAY FERRY
DIESEL ENGINE
TROUBLESHOOTING PROCEDURES**

INITIAL SETUP:**Personnel Required**

Engineer 88L

References

TM 55-1945-205-10-1

TM 55-1945-205-24-1-1

TROUBLESHOOTING PROCEDURE

ELECTRICAL GENERATING SYSTEM SHOWS FULLY CHARGED BATTERY AND HIGH CHARGING RATE

NOTE

The following procedure is typical for both port and starboard engines.

SYMPTOM

Electrical generating system shows fully charged battery and high charging rate.

MALFUNCTION

Voltage regulator is set too high or not limiting alternator output.

CORRECTIVE ACTION

Replace voltage regulator. (TM 55-1945-205-24-1-1)

Perform operational check of the charging system. (TM 55-1945-205-10-1)

END OF WORK PACKAGE

**UNIT, DIRECT SUPPORT AND GENERAL SUPPORT MAINTENANCE
CAUSEWAY FERRY
DIESEL ENGINE
TROUBLESHOOTING PROCEDURES**

INITIAL SETUP:**Test Equipment**

Multimeter (Item 84, WP 0188 00)

Personnel Required

Engineer 88L

References

TM 55-1945-205-10-1

TROUBLESHOOTING PROCEDURE

ELECTRONIC GOVERNOR ACTUATOR STAYS AT MINIMUM POSITION WHEN POWER IS APPLIED

NOTE

The following procedure is typical for both port and starboard engines.

SYMPTOM

Electronic governor, engine junction box A4, is completely dead, actuator lever stays at minimum position when power is applied to governor.

MALFUNCTION

No battery voltage at terminals 1 and 2 on controller.

CORRECTIVE ACTION

Use a multimeter to check electrical connections and contacts for power at the controller.

Perform operational check of the electronic governor actuator. (TM 55-1945-205-10-1)

MALFUNCTION

Binding or defective linkage.

CORRECTIVE ACTION

Inspect and free governor rod assembly. (WP 0097 00)

Perform operational check of the electronic governor actuator. (TM 55-1945-205-10-1)

MALFUNCTION

Binding electronic governor drive.

CORRECTIVE ACTION

Repair electronic governor drive assembly. (WP 0102 00)

MALFUNCTION

Binding injector rack control lever.

CORRECTIVE ACTION

Adjust injector rack control lever. (WP 0093 00)

MALFUNCTION

Magnetic pick-up signal absent or too low.

CORRECTIVE ACTION

Using a multimeter with an impedance of 5000 ohms/volts or higher, measure AC voltage across terminals 10 and 11. Voltage should be minimum 2.5 VAC. If voltage is not 2.5 VAC, replace governor actuator (WP 0098 00) or magnetic pick-up as necessary. (WP 0100 00)

Perform operational check of the electronic governor actuator. (TM 55-1945-205-10-1)

MALFUNCTION

Open or shorted pick-up coil.

CORRECTIVE ACTION

Using a multimeter, measure the resistance of the magnetic pick-up coil. It should be above 150 ohms. If it is not, there is an open or shorted coil. Replace the magnetic pick-up. (WP 0100 00)

Perform operational check of the electronic governor actuator. (TM 55-1945-205-10-1)

Using a multimeter, measure the resistance of each pin to the metal case of the magnetic pick-up. No continuity should be evident. If there is continuity to case, replace magnetic pick-up. (WP 0100 00)

Perform operational check of the electronic governor actuator. (TM 55-1945-205-10-1)

MALFUNCTION

Interruption or weak DC power supply.

CORRECTIVE ACTION

With DC power supply off, place an insulated jumper between terminals 2 and 3 (TP1 & TP2). Turn DC power on. Actuator should go to full stroke. DC voltage at terminals 4 and 5 should be within 3 volts of the supply. If actuator does not move to full stroke, continue with steps below.

Perform operational check of the electronic governor actuator. (TM 55-1945-205-10-1)

MALFUNCTION

Actuator coil is open or shorted.

CORRECTIVE ACTION

If actuator is open or shorted to case, replace actuator. (WP 0098 00) If governor still does not operate, continue with steps below.

Perform operational check of the electronic governor actuator. (TM 55-1945-205-10-1)

Using a multimeter, measure resistance of actuator coil. Coil resistance should be within 2.3 ohms + /- 0.2 ohms. If resistance is not within factory limits, replace actuator. (WP 0098 00)

Perform operational check of the electronic governor actuator. (TM 55-1945-205-10-1)

MALFUNCTION

Resistance of coil lead to actuator case is improper.

CORRECTIVE ACTION

Using a multimeter, measure resistance of each coil lead to the actuator case. An open circuit is indicated by a low scale reading on the ohm meter. If continuity is detected, replace actuator. (WP 0098 00)

Perform operational check of the electronic governor actuator. (TM 55-1945-205-10-1)

MALFUNCTION

Incorrect voltage between terminal 6 and terminal 2.

CORRECTIVE ACTION

With DC power to the governor on and the engine off, measure the DC voltage from terminal 6 (+) to terminal 2 (-). It should be approximately 8 VDC. If 8 VDC is not present, replace the controller. (WP 0099 00)

Perform operational check of the electronic governor actuator. (TM 55-1945-205-10-1)

MALFUNCTION

Incorrect voltage between terminal 7 and terminal 2.

CORRECTIVE ACTION

With DC power to the governor on and the engine off, measure the DC voltage from terminal 7 (+) to terminal 2 (-). It should be approximately 4 VDC. If 4 VDC is not present, replace the controller. (WP 0099 00)

Perform operational check of the electronic governor actuator. (TM 55-1945-205-10-1)

END OF WORK PACKAGE

**UNIT, DIRECT SUPPORT AND GENERAL SUPPORT MAINTENANCE
CAUSEWAY FERRY
DIESEL ENGINE
TROUBLESHOOTING PROCEDURES**

INITIAL SETUP:**Test Equipment**

Multimeter (Item 84, WP 0188 00)

Personnel Required

Engineer 88L

References

TM 55-1945-205-10-1

TM 55-1945-205-24-1-1

TROUBLESHOOTING PROCEDURE

ELECTRONIC GOVERNOR GOES TO FULL STROKE WHEN DC POWER IS APPLIED AND ENGINE IS NOT OPERATING

NOTE

The following procedure is typical for both port and starboard engines.

SYMPTOM

Electronic governor actuator goes to full stroke when DC power is applied, and engine is not operating.

MALFUNCTION

Magnetic pick-up leads not shielded.

CORRECTIVE ACTION

Verify magnetic pickup leads are shielded. If they are not, correct wiring as necessary.
(TM 55-1945-205-24-1-1)

Perform operational check of the electronic governor actuator. (TM 55-1945-205-10-1)

MALFUNCTION

Damaged magnetic pick-up coil.

CORRECTIVE ACTION

Replace electronic governor magnetic pick-up. (WP 0100 00)

Perform operational check of the electronic governor actuator. (TM 55-1945-205-10-1)

MALFUNCTION

Improperly adjusted magnetic pick-up.

CORRECTIVE ACTION

Adjust magnetic pick-up. (WP 0100 00)

Perform operational check of the electronic governor actuator. (TM 55-1945-205-10-1)

MALFUNCTION

Short between terminals 2 and 3.

CORRECTIVE ACTION

Inspect and correct wiring as necessary. (TM 55-1945-205-24-1-1)

Perform operational check of the electronic governor actuator. (TM 55-1945-205-10-1)

MALFUNCTION

Fail safe circuit in controller is damaged or defective.

CORRECTIVE ACTION

Replace controller. (WP 0099 00)

Perform operational check of the electronic governor actuator. (TM 55-1945-205-10-1)

MALFUNCTION

Continuity between a terminal and controller case.

CORRECTIVE ACTION

With DC power off, remove leads at actuator. Using a multimeter, check continuity of each terminal to case. There should be no continuity between any terminal and the controller case. If continuity is detected, replace the controller. (WP 0099 00)

Perform operational check of the electronic governor actuator. (TM 55-1945-205-10-1)

MALFUNCTION

Remote speed potentiometer wiring has open or shorted circuits.

CORRECTIVE ACTION

Disconnect potentiometer leads from terminals 6, 7 and 9. Turn DC power on to the governor if the actuator is now normal. Proceed to TM 55-1945-205-24-1-1 to diagnose cause of potentiometer wiring problem.

Perform operational check of the electronic governor actuator. (TM 55-1945-205-10-1)

END OF WORK PACKAGE

CHAPTER 3

**UNIT, DIRECT SUPPORT AND GENERAL SUPPORT
MAINTENANCE INSTRUCTIONS
FOR
MODULAR CAUSEWAY SYSTEM (MCS)
CAUSEWAY FERRY (CF) ENGINE**

**UNIT LEVEL MAINTENANCE
CAUSEWAY FERRY
ENGINE
SERVICE UPON RECEIPT**

INITIAL SETUP:**Tools**

Tool Kit, General Mechanic's (Rail and Marine) (Item 131, WP 0188 00)

Personnel Required

Engineer 88L

References

TM 55-1945-205-24-1-1

INSPECT ENGINE

1. Inspect engine for damage that might have occurred during shipment.
2. Report any damage to your supervisor.

PROCESS ENGINE

1. Replace fuel system filter. (TM 55-1945-205-24-1-1)
2. Replace fresh water filter element. (TM 55-1945-205-24-1-1)
3. Replace engine oil filter element. (TM 55-1945-205-24-1-1)

END OF WORK PACKAGE

**UNIT LEVEL MAINTENANCE
CAUSEWAY FERRY
ENGINE
PREVENTIVE MAINTENANCE CHECKS AND SERVICES (PMCS)
PROCEDURES INTRODUCTION**

INTRODUCTION

General

Preventive Maintenance Checks and Services (PMCS) are performed to keep the causeway ferry (CF) engine in operating condition. The checks are used to find, correct or report problems.

If you find something wrong when performing PMCS, fix it if you can, using troubleshooting procedures and/or maintenance procedures.

The right-hand column of the PMCS table list conditions that make the vessel not fully mission capable. Write up items not fixed on DA Form 2404. For further information on how to use this form, see DA PAM 738-750.

Leakage Definition

CAUTION

Equipment operation is allowed with minor leakages (Class I or II), except for fuel leaks. Of course, consideration must be given to the fluid capacity of the item or system being checked. When in doubt, ask your supervisor. Failure to maintain proper fluid levels could result in damage to equipment.

When operating with Class I or II leaks, continue to check fluid levels as required in your PMCS.

Class III leaks should be reported immediately to your supervisor.

It is necessary to know how fluid leakage affects the status of the equipment. The following are definitions of the classes of leakage an operator or crew member needs to know to be able to determine the condition of the leak. Learn and then be familiar with them and REMEMBER - WHEN IN DOUBT, ASK YOUR SUPERVISOR.

Leakage definitions for PMCS.

CLASS I - Seepage of fluid (as indicated by wetness or discoloration) not great enough to form drops.

CLASS II - Leakage of fluid great enough to form drops, but not enough to cause drops to drip from item being checked.

CLASS III - Leakage of fluid great enough to form drops that fall from the item being checked.

Inspection

Look for signs of a problem or trouble. Senses help here. You can feel, smell, hear or see many problems. Be alert when on the equipment.

Inspect to see if items are in good condition. Are they correctly assembled, stowed, secured, excessively worn, leaking, corroded or properly lubricated? Correct any problems found or notify your supervisor.

There are some common items to check all over the equipment. These include the following:

1. Bolts, clamps, nuts and screws: continuously check for looseness. Tighten them when you find them loose.
2. Chipped paint, bare metal, rust or corrosion around bolt, screw heads and nuts. Clean and repair/repaint as necessary.
3. Welds: Many items on the equipment are welded. To check these welds, look for chipped paint, rust, corrosion or gaps. When these conditions exist, write them up on DA Form 2404.
3. Electrical wires, connectors and harnesses: cracked or broken insulation, bare wires and broken connectors. Repair/replace as necessary.
4. Inspect hoses and fluid lines for: wear, damage, leaks, loose clamps and fittings. Wet spots mean a leak. A stain by a fitting or connector can also mean a leak. Repair/replace as necessary.

Lubrication Service Intervals - Normal Conditions

For safer, more trouble free operations, make sure that your equipment is serviced when it needs it. For the proper lubrication and service intervals, see the PMCS section of this manual.

Lubrication Service Intervals - Unusual Conditions

Your equipment will require extra service and care when you operate under unusual conditions. High or low temperatures or long periods of hard use will break down the lubricant, requiring you to add or change lubricant more often.

Lubrication Interval

The following lubrication interval symbols are used in the PMCS table:

M - monthly	Q - quarterly
S - semiannually	H - hours operated
A - annually	

Oil Filters

Oil filters shall be serviced/cleaned/changed, as applicable, when:

They are known to be contaminated or clogged.

Service is recommended by AOAP laboratory analysis.

At prescribed hard time intervals.

Army Oil Analysis Program (AOAP)

The CF diesel engine must be sampled every 90 days or 100 operating hours, whichever occurs first. Refer to DA PAM 738-750, Functional Users Guide for The Army Maintenance Management System.

Warranty Information

For equipment under manufacturer's warranty, hard time oil service intervals shall be followed. Intervals shall be shortened if lubricants are known to be contaminated or if operation is under adverse conditions, such as: longer than usual operating hours, extended idling period or extreme dust.

Cleaning And Lubrication

Proper cleaning and lubrication can aid in avoiding possible problems or trouble, so make it a habit to do the following:

CAUTION

Follow all cleaning and lubrication instructions carefully, failure to do so can result in damage to equipment.

1. Thoroughly wash all equipment exposed to salt spray with clean fresh water.
2. Clean parts to be lubricated with cleaner MIL-C-29602. Wipe surface dry before lubricating.
3. Use cleaner MIL-C-29602 on fouled parts.
4. Clean grease fittings before lubrication.
5. Lubricate all equipment at conclusion of the operation before equipment storage.
6. Always use the PMCS lubrication instructions as a guide.
7. Never use too much lubricant.
8. Never use the wrong type or grade of lubricant.
9. Lubricate more during constant use and less during inactive periods.

Corrosion Prevention And Control (CPC)

Corrosion Prevention and Control (CPC) of Army materiel is a continuing concern. It is important that any corrosion problems with this item be reported so that the problem can be corrected and improvements can be made to prevent the problem in future items.

Corrosion is typically associated with rusting of metals or galvanic corrosion which produces a white powder. The category of corrosion also includes deterioration of other materials, such as rubber and plastic. Unusual cracking, softening, swelling or breaking of the materials may be a corrosion problem. If a corrosion problem is identified, it can be reported using SF 368, Product Quality Deficiency Report. Use of key words, such as "corrosion", "rust", "deterioration" or "cracking", will ensure that the information is identified as a CPC problem. The form should be submitted to the address specified in DA PAM 738-750.

**UNIT LEVEL MAINTENANCE
CAUSEWAY FERRY
ENGINE
PREVENTIVE MAINTENANCE CHECKS AND SERVICES (PMCS)
AND LUBRICATION PROCEDURES**

INITIAL SETUP:

Personnel Required

Engineer 88L

References

TB 55-1900-207-24

1. Engine Cold Pack Starting Aid
2. Engine Cooling System
3. Engine Fuel Filter
4. Engine Air Filter Elements
5. Engine Cooling System Anodes
6. Engine Oil and Fuel Lines and Hoses
7. Engine Lubricating System
8. Engine Ventilation System
9. Engine Blower
10. Engine Water Pump

Not Shown 1, 6, and 7

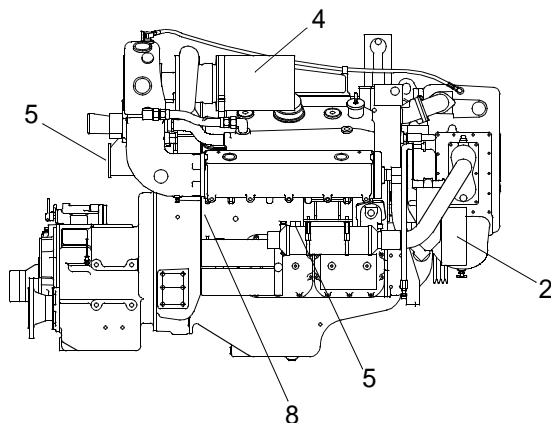
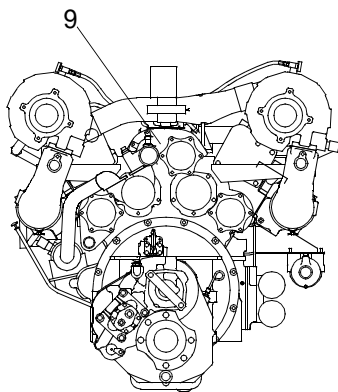
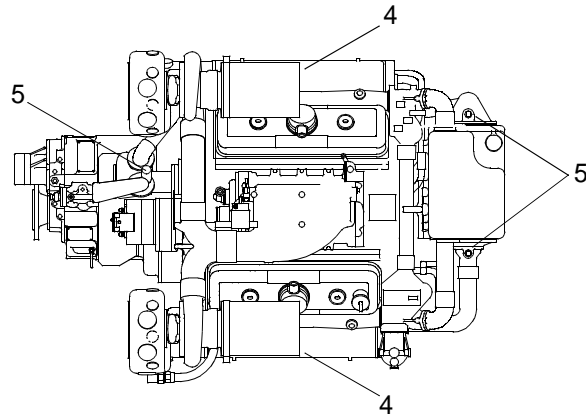
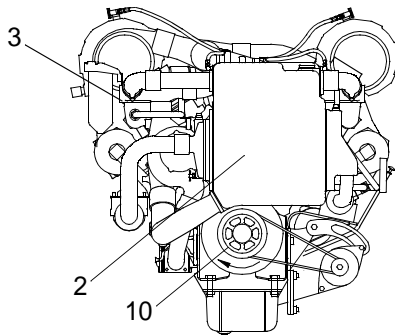
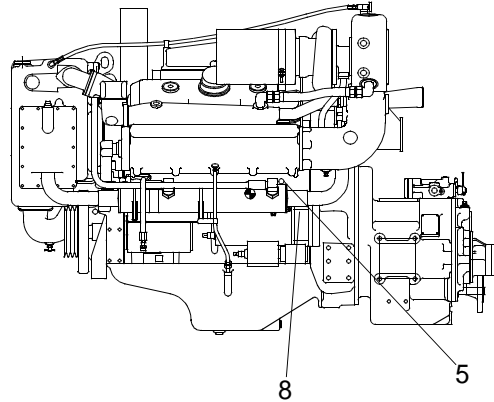

Table 1. Preventive Maintenance Checks and Services for the Causeway Ferry.

ITEM NO.	INTERVAL	MAN-HOURS	ITEM TO BE CHECKED OR SERVICED	PROCEDURE	EQUIPMENT NOT READY/ AVAILABLE IF:
1	Monthly 200 Operating Hours	.5	Engine Cold-Pack Starting Aid	Weigh the cold pack starting aid fluid cylinder monthly or every 200 operating hours, whichever occurs first. Empty container weighs 16 oz (238 gr), full cylinder weighs 37 oz (510 gr). (WP 0171 00)	
2	Quarterly 200 Operating Hours	.5	Engine Cooling System	1. Test the Supplemental Coolant Additive (SCA) level quarterly or every 200 operating hours, whichever occurs first. (TB 55-1900-207-24) 2. Replace the fresh water filter if the nitrate concentration is below 800 ppm. (WP 0140 00)	
3	Semi- annually 300 Operating Hours	3.0	Engine Fuel Filter	Replace engine secondary fuel filter semi-annually or every 300 operating hours, whichever occurs first. (WP 0079 00)	
2	Semi- annually 500 Operating Hours	3.0	Engine Cooling System	Replace fresh water coolant filter semi-annually or 500 operating hours, whichever comes first. (WP 0140 00)	
4	Annually	1.0	Engine Air Filter Elements	1. Replace engine air filter elements. (WP 0105 00) 2. Clean engine air inlet collector. (WP 0105 00) 3. Clean engine crankcase breather limiters. (WP 0106 00)	
5	Annually 500 Operating Hours	20.0	Engine Cooling System Anodes	1. Remove heat exchanger and raw water pump anodes annually or 500 operating hours, whichever comes first. Clean anodes. Replace if worn excessively. (WP 0156 00, WP 0157 00, WP 0158 00, WP 0159 00)	

Table 1. Preventive Maintenance Checks and Services for the Causeway Ferry. (Continued)

ITEM NO.	INTERVAL	MAN-HOURS	ITEM TO BE CHECKED OR SERVICED	PROCEDURE	EQUIPMENT NOT READY/ AVAILABLE IF:
5	Annually 500 Operating Hours	20.0	Engine Cooling System Anodes (Cont'd)	2. Clean the exterior of the heat exchanger fins annually or 500 operating hours, whichever comes first. (WP 0137 00) 3. Functionally test cooling system thermostat annually or 500 operating hours, whichever comes first. (WP 0146 00)	
6	Annually 500 Operating Hours	.1	Engine Oil and Fuel Lines and Hoses	Check oil and fuel hoses for signs of deterioration annually or 500 operating hours, whichever comes first. Replace hoses as necessary. (WP 0117 00, WP 0118 00, WP 0080 00)	Any Class I fuel leakage is found.
2	Biennially 4,000 Operating Hours	3.0	Engine Cooling System	Replace fresh water coolant biennially or 4,000 operating hours, whichever comes first. (WP 0134 00)	
7	150 Operating Hours	1.0	Engine Lubricating System	Change diesel engine crankcase lubricating oil every 150 operating hours or in accordance with AOAP. (WP 0115 00)	
8	1,000 Operating Hours	1.5	Engine Ventilation System	1. With the engine running, check for flow of air from the air box drain tubes. Clean tubes as required. (WP 0036 00) 2. Remove crankcase breather and clean steel mesh pad. (WP 0044 00)	
9	1,000 Operating Hours	1.5	Engine Blower	Remove, inspect and clean blower screen. (WP 0110 00)	
9	3,000 Operating Hours	1.5	Engine Blower	Clean the blower bypass valve using cleaner. (WP 0108 00)	

Table 1. Preventive Maintenance Checks and Services for the Causeway Ferry. (Continued)

ITEM NO.	INTERVAL	MAN-HOURS	ITEM TO BE CHECKED OR SERVICED	PROCEDURE	EQUIPMENT NOT READY/ AVAILABLE IF:
10	6,000 Operating Hours	1.5	Engine Water Pump	Replace fresh water pump seal. (WP 0154 00)	
6	5 Years	20.0	Engine Oil and Fuel Lines and Hoses	Replace all fuel and oil hoses in or out of engine during major engine overhaul or five years, whichever occurs first. (WP 0117 00, WP 0118 00, WP 0080 00)	

END OF WORK PACKAGE

**DIRECT SUPPORT MAINTENANCE
CAUSEWAY FERRY
ENGINE
TUNE-UP**

INITIAL SETUP:**Personnel Required**Engineer 88L

PERFORM ENGINE TUNE-UP

1. Perform exhaust valve clearance adjustment. (WP 0045 00)
2. Perform fuel injector timing. (WP 0092 00)
3. Perform ignition modulator assembly adjustment. (WP 0090 00)
4. Perform fuel injector rack control lever adjustment. (WP 0093 00)
5. Perform engine compression check. (WP 0030 00)
6. Perform overspeed governor adjustment. (WP 0175 00)
7. Perform electronic governor adjustment. (WP 0099 00)

END OF WORK PACKAGE

**UNIT LEVEL MAINTENANCE
CAUSEWAY FERRY
DIESEL ENGINE MOUNTS
INSPECTION**

INITIAL SETUP:**Tools**

Tool Kit, General Mechanic's (Rail and Marine) (Item 131, WP 0188 00)

Personnel Required

Engineer 88L

INSPECT ENGINE MOUNTS

1. Inspect three engine mounts (1) and two marine gear mounts (2) for cracks, bends and broken or missing hardware (3). If found contact depot maintenance.

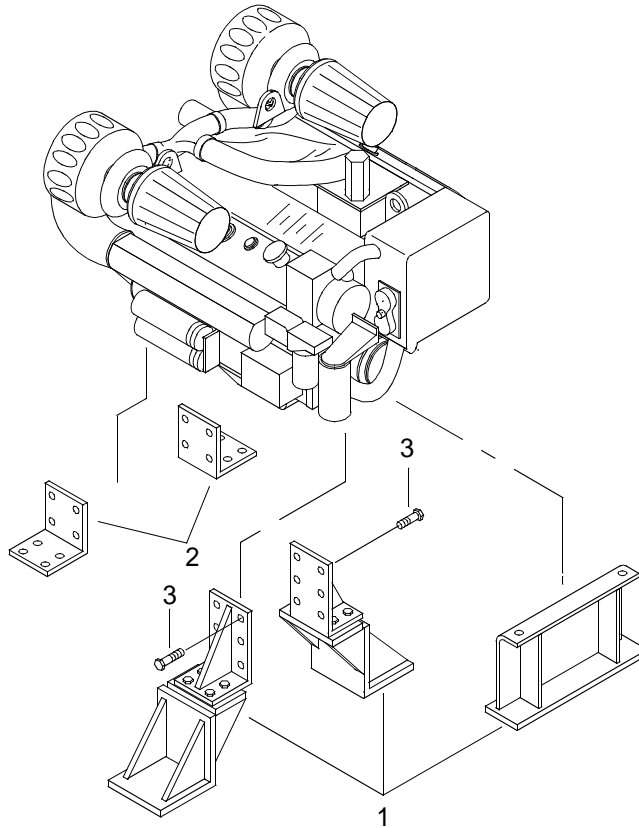

2. Inspect welds for cracks and or breaks. If found contact depot maintenance.

END OF WORK PACKAGE

**DIRECT SUPPORT MAINTENANCE
CAUSEWAY FERRY
ENGINE
TESTING**

INITIAL SETUP:**Test Equipment**

Kit, Diesel Engine, Diagnosis (Item 76, WP 0188 00)

Tools

Tool Kit, General Mechanic's (Item 130, WP 0188 00)

Personnel Required

Engineer 88L

References

TM 55-1945-205-10-1

Equipment Condition

Engine Cool To Touch.

SINCGARS Antenna Removed. (TM 11-5820-890-10-8)

Main Navigation Mast Removed. (TM 55-1945-205-24-1-1)

Intake Plenum Assembly Removed. (TM 55-1945-205-24-1-1)

Operators Cab Removed. (TM 55-1945-205-24-1-1)

Engine Hatch Removed. (TM 55-1945-205-24-1-1)

PERFORM ENGINE COMPRESSION TEST

1. Start engine and run until normal operating temperature is reached. (TM 55-1945-205-24-1-1)
2. Stop engine. (TM 55-1945-205-24-1-1)
3. Remove crankcase breather limiter assembly. (WP 0106 00)
4. Remove air inlet collector assembly. (WP 0104 00)
5. Remove cylinder head poppet valve rocker arm covers. (WP 0043 00)

WARNING**CHEMICAL****EYE PROTECTION****FIRE****HOT AREA**

6. Remove fuel pipes (1 and 2) from injector (3) and fuel manifolds (4).

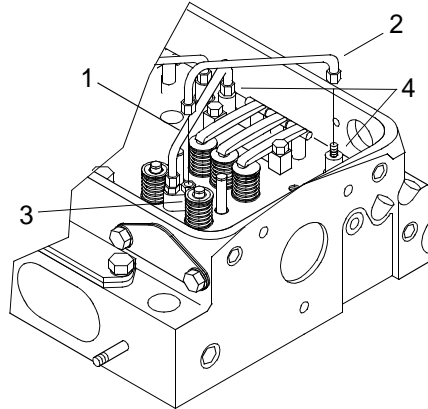

7. Remove fuel injector (3). (WP 0091 00)

NOTE

The adaptor and pressure gauge are installed in the same way the injector is installed.

8. Install adaptor (5) and pressure gauge (6) from the diesel engine diagnosis kit into the vacant injector orifice.

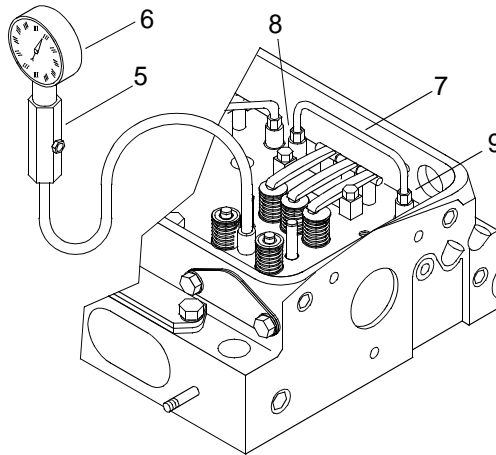

WARNING



CHEMICAL



EYE PROTECTION



FIRE



HOT AREA

Do not permit fuel from the inlet manifold to leak over hot engine. Failure to comply could result in serious injury or death of personnel.

9. Use a spare fuel pipe to fabricate a jumper connection (7) between the fuel inlet (8) and return manifold connector (9).

CAUTION

Engine must be running to obtain accurate compression reading. Do not crank starter motor to obtain compression reading, damage to equipment could occur.

10. Start engine and run at 600 RPM. (TM 55-1945-205-10-1)

NOTE

The compression in any cylinder must not be less than 450 PSI (3102.6 kPa) at sea level.
The variation in compression between cylinders must not exceed 25 PSI (172.4 kPa).

11. Record compression reading shown on pressure gauge (6).
12. Repeat steps 3 through 7 to check compression in each of the remaining cylinders.
13. Stop engine. (TM 55-1945-205-10-1)
14. Disconnect fuel pipe jumper (7) between the fuel inlet manifold (8) and the return manifold (9).
15. Remove adaptor (5) and pressure gauge (6) from the injector orifice.
16. Install fuel injector. (WP 0091 00)
17. Install fuel pipes (1 and 2) on injector (3) and fuel connectors (4).
18. Install cylinder head poppet valve rocker arm covers. (WP 0043 00)
19. Install air inlet collector assembly. (WP 0104 00)
20. Install crankcase breather limiter assembly. (WP 0106 00)
21. Install engine/thruster hatch. (TM 55-1945-205-24-1-1)
22. Install operators cab. (TM 55-1945-205-24-1-1)
23. Install intake plenum assembly. (TM 55-1945-205-24-1-1)
24. Install main navigation mast. (TM 55-1945-205-24-1-1)
25. Install SINGARS antenna. (TM 11-5820-890-10-8)
26. Perform operational check. (TM 55-1945-205-10-1)

END OF WORK PACKAGE

**DIRECT SUPPORT MAINTENANCE
CAUSEWAY FERRY
ENGINE
REMOVAL AND INSTALLATION**

INITIAL SETUP:**Tools**

Tool Kit, General Mechanic's (Item 130, WP 0188 00)
Sling, 5300 lb 6 ft (Item 118, WP 0188 00)
Qty 4
Shackle, ¾ in. 4.75 Ton (Item 116, WP 0188 00)
Qty 3
Hoist, Chain (Item 65, WP 0188 00)
Wrench, Torque (0-175 ft lbs) (Item 138, WP 0188 00)
Pan, Drain (Item 87, WP 0188 00)
Gloves, Chemical (Item 52, WP 0188 00)
Goggles, Industrial (Item 54, WP 0188 00)
Respirator, Air Filtering (Item 109, WP 0188 00)
Stand, Maintenance, Automotive Engine (Item 120, WP 0188 00)

Materials/Parts

Twine, Fibrous (Item 37, WP 0187 00)
Straps, Tiedown (Item 33, WP 0187 00)
Spill Clean-Up Kit, Hazardous Material (Item 32, WP 0187 00)
Lumber, Softwood, Dimension (4 in. X 4 in. X 6 ft Min Wooden Blocks) (Item 24, WP 0187 00)

Personnel Required

Engineer 88L (2)

References

TM 55-1945-205-10-1

Equipment Condition

Engine Cool To Touch.
Main Batteries Negative Leads Removed. (TM 55-1945-205-24-1-1)
Main Navigation Mast Removed. (TM 55-1945-205-24-1-1)
SINCGARS Antenna Removed. (TM 11-5820-890-10-8)
Operators Cab Or Air Intake Plenum Removed. (TM 55-1945-205-24-1-1)
Engine Hatch Removed. (TM 55-1945-205-24-1-1)
Exhaust System Removed. (TTM 55-1945-205-24-1-1)
Marine Gear To Transfer Case Machinery Guard Removed. (TM 55-1945-205-24-1-1)
Marine Gear To Transfer Case Drive Shaft Removed. (TM 55-1945-205-24-1-1)
Engine Crankcase Oil Drained. (WP 0115 00)
Fast Lube System Removed. (TM 55-1945-205-24-1-1)
Fresh Water Cooling System Drained. (WP 0134 00)
Hydraulic System Pressure Vented. (TM 55-1945-205-24-1-1)
Hydraulic Pump Removed. (TM 55-1945-205-24-1-1)
Marine Gear Oil Pump Removed. (TM 55-1945-205-24-1-3)

REMOVE ENGINE

1. Verify fuel supply and return valves (1) are closed.

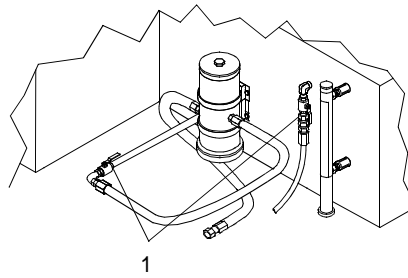

2. Remove nut (2) and bolt (3) securing fire suppression trip mechanism solenoid (4) to its mount, located above the engine.

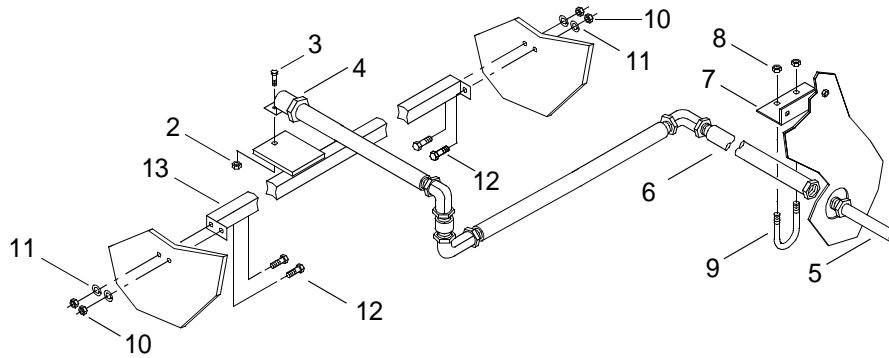

3. Using a pipe wrench, disconnect the pipe coupling (5) for the fire suppression CO2 supply line (6) that feeds the trip mechanism solenoid (4) near the propulsion module frame cross-member support bracket (7).
4. Remove the two nuts (8) and U-joint bolt (9) supporting the CO2 line (6) to the propulsion module frame cross-member support bracket (7).
5. Remove the CO2 line (6) with attached trip mechanism solenoid (4).
6. Remove the four nuts (10), lock washers (11) and bolts (12) securing the fire suppression trip mechanism solenoid's cross-module bracket (13) to the propulsion module longitudinal frame.
7. Remove the cross-module bracket (13).

WARNING**EXPLOSION****VAPOR**

8. Disconnect cold pack starting supply line (14) from starboard side of air inlet housing (15) and secure outboard with twine.

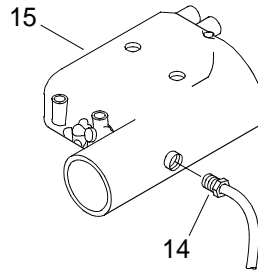

9. Tag and disconnect the two red battery power leads from the starter solenoid (16) and alternator (17).

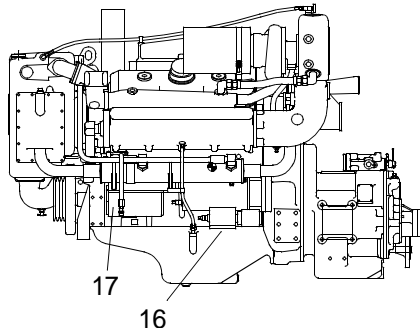

10. Remove inline tiedown straps, pull the leads off the engine and secure the leads outboard with twine.
11. Inside the engine junction box A4 (18), tag and disconnect all the terminal leads associated with the main engine electrical wire bundle (19).

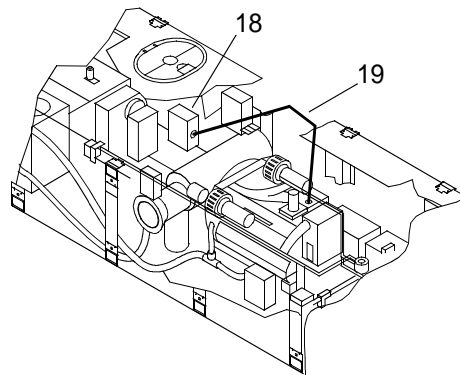

12. Once the wire bundle (19) is isolated from the engine junction box A4 (18), remove tiedown straps and coil and secure the wire bundle on top of the engine with twine.

13. Position drain pan beneath the fuel supply line check valve (20) located near the forward starboard end of the engine.

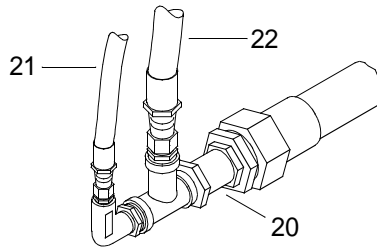

WARNING



CHEMICAL

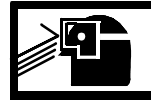

EYE PROTECTION

14. Remove fuel primer pump supply line (21) from the fuel supply line check valve (20).

WARNING



CHEMICAL



EYE PROTECTION

15. Remove fuel pump supply line (22) from the fuel supply line check valve (20).

NOTE

The main fuel supply line with attached check valve will remain in the bilge and will not interfere with engine removal.

16. Secure the two fuel supply lines (21 and 22) to the engine with twine.
17. Position drain pan beneath the fuel pump return line (23) coupling, located on the forward port side of the engine.

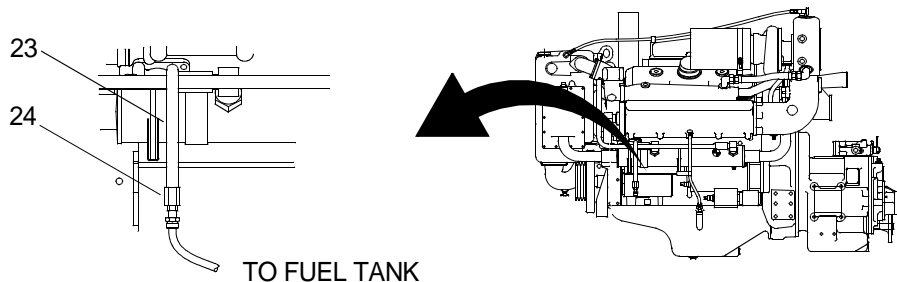

WARNING**CHEMICAL****EYE PROTECTION**

18. Remove fuel pump return line (23) from the main fuel return line (24).

NOTE

The main fuel return line will remain in the bilge and will not interfere with engine removal.

19. Secure the fuel pump return line (23) to the engine with twine.

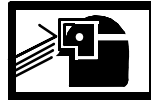
WARNING**CHEMICAL****EYE PROTECTION**

20. Remove drain pan and dispose of contents in accordance with local procedures.
21. Tag and disconnect two marine gear shifting solenoid electrical connectors (25) from the two marine gear selector valve solenoids (26) and secure to engine with twine.

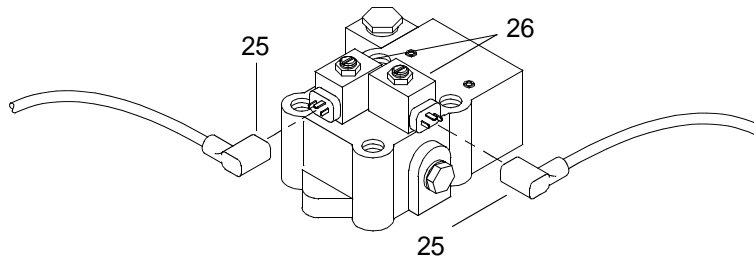

22. Remove three pipe plugs (27) from duplex strainer (28) and allow raw water system to drain into the bilge.

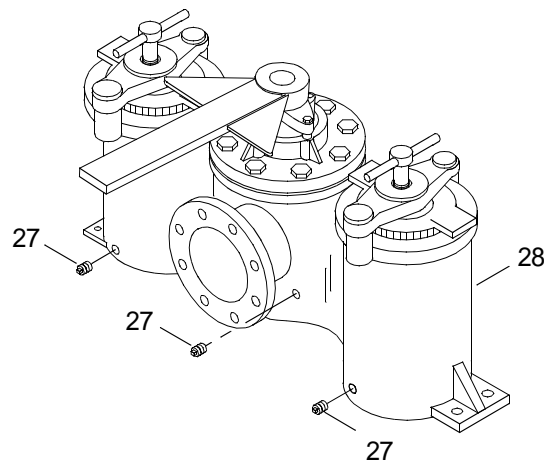

23. When raw water system is drained, install three pipe plugs (27) in duplex strainer (28).

24. Loosen two hose clamps (29) and remove raw water supply hose (30) from raw water pump coupling (31).

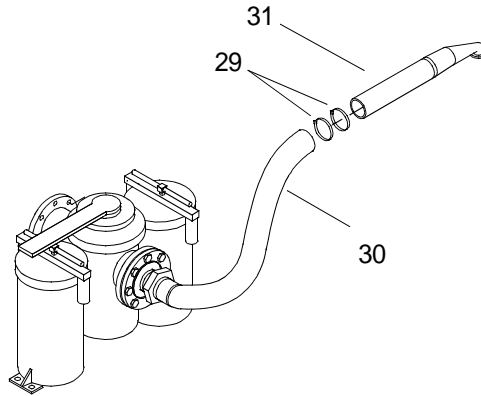

25. Secure raw water supply hose (30) outboard with twine.
26. Loosen two hose clamps (32) and remove the raw water return hose (33) from marine gear cooler coupling (34), located aft and starboard of the marine gear.

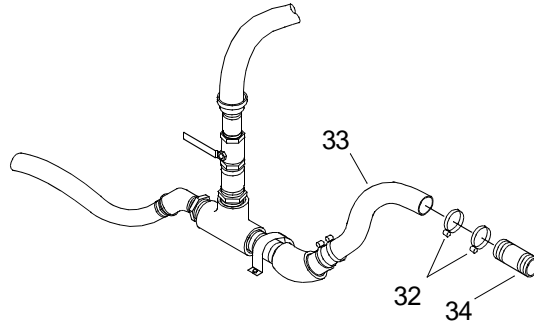

27. Secure raw water return hose (33) outboard with twine.
28. Disconnect oil filter supply line (35) and oil filter return line (36) from engine oil cooler (37).

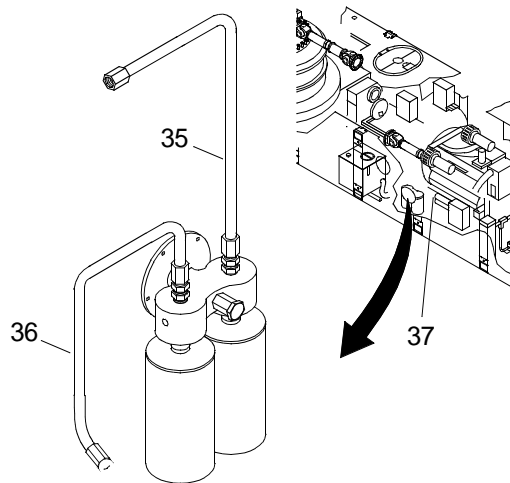

29. Secure hoses (35 and 36) outboard with twine.

30. Attach three slings and shackles to the three lifting brackets (38) on top of the engine.

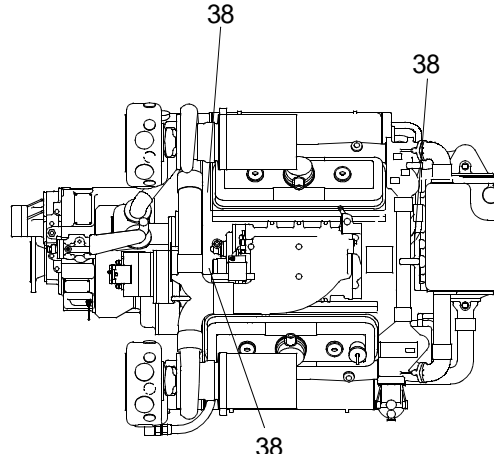

WARNING



HEAVY PARTS

Do not attempt to lift the engine with any less than a three point hook-up. Failure to comply could result in injury to personnel and damage to the equipment.

NOTE

Use a sling and chain hoist to support the marine gear and keep the engine and marine gear level during removal.

31. Using crane, place tension on the slings to prevent the engine from shifting off the mounts during removal of the mounting bolts.
32. Remove eight bolts (39) and nuts (40) securing two marine gear mounting brackets (41) to two hull mounts (42).

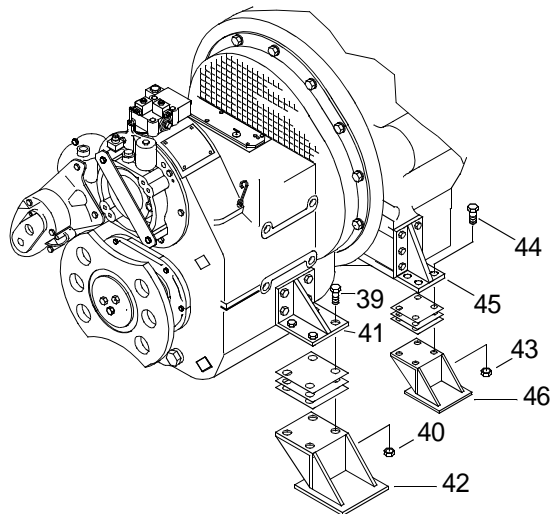

33. Remove eight nuts (43) and bolts (44) securing two aft engine mounting brackets (45) to two aft hull mounts (46).

34. Remove two nuts (47) and bolts (48) and shims (49) securing forward engine mounting bracket (50) to forward hull saddle mount (51).

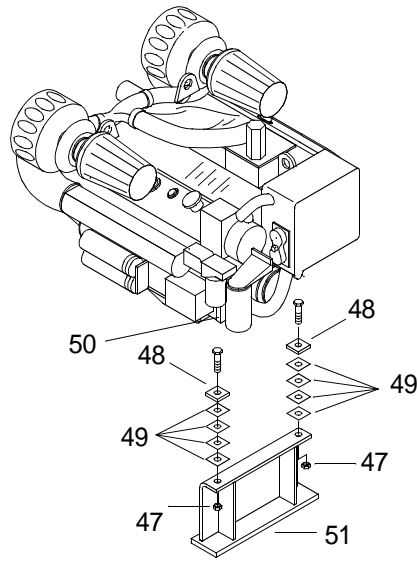

WARNING



HEAVY PARTS

Do not attempt to lift the engine with any less than a three point hook-up. Failure to comply could result in injury to personnel and damage to the equipment.

NOTE

Use a sling and chain hoist to support the marine gear and keep the engine and marine gear level during removal.

35. Using crane (52), a chain hoist (53), three slings (54) on the engine and a sling (55) on the marine gear (56), remove engine with marine gear (56) from the propulsion module.

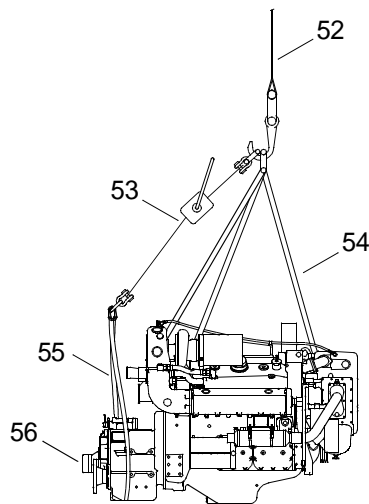

WARNING**HEAVY PARTS**

36. Place the engine with marine gear (56) on wooden blocks or suitable engine stand to facilitate equipment separation.
37. Secure all marine gear (56) and engine mounting shims (49) to their associated mount locations with twine.
38. Remove the marine gear (56) from the rear of the engine.
 - a. Remove the twelve hex head cap screws (57) and washers (58) securing marine gear to the engine.

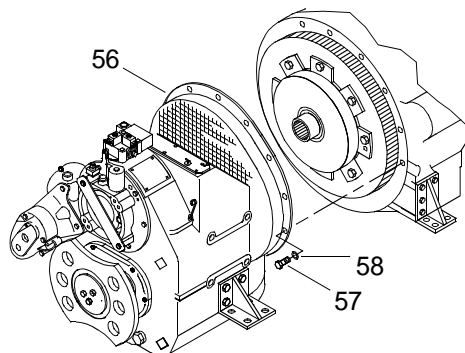
**WARNING****HEAVY PARTS**

- b. Using crane and loop sling, remove marine gear (56) from engine.

INSTALL ENGINE

1. Install the marine gear (56) on the rear of the engine.

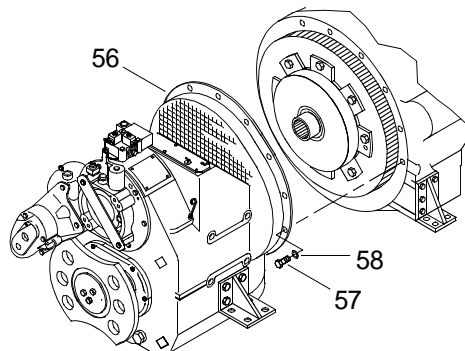

WARNING

**HEAVY PARTS**

- a. Using crane and loop sling, position marine gear (56) on rear of engine.
 - b. Install the twelve hex head cap screws (57) and washers (58) securing marine gear (56) to the engine.
 - c. Using torque wrench, torque cap screws (57) to 55 ft lbs (74.58 N-m).
2. Remove twine securing all mounting shims to engine mounts (51) and marine gear hull mounts (42).

WARNING

**HEAVY PARTS**

Do not attempt to lift the engine with any less than a three point hook-up. Failure to comply could result personnel injury and damage to the equipment.

NOTE

Use a sling and chain hoist to support the marine gear and keep the engine and marine gear level during installation.

3. Using crane (52), chain hoist (53), three slings (54) on the engine and a sling (55) on the marine gear (56), lower engine with attached marine gear (56) into the propulsion module and position on shims and hull mounts.

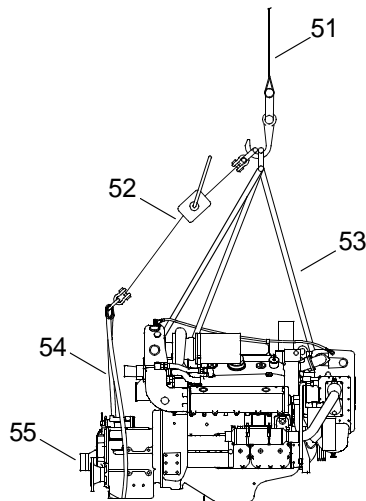

4. Install two bolts (48) and nuts (47) to secure the forward engine mounting bracket (50) to the forward hull saddle mount (51) and tighten nuts (47).

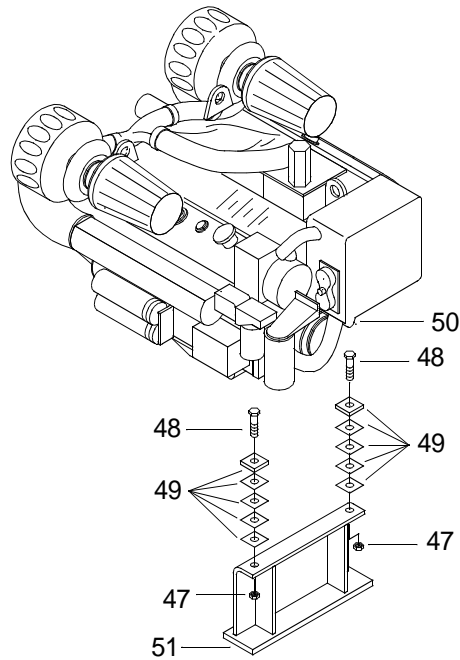

5. Install eight bolts (44) and nuts (43) to secure the two aft engine mounting brackets (45) to the two aft hull mounts (46) and tighten nuts (43).

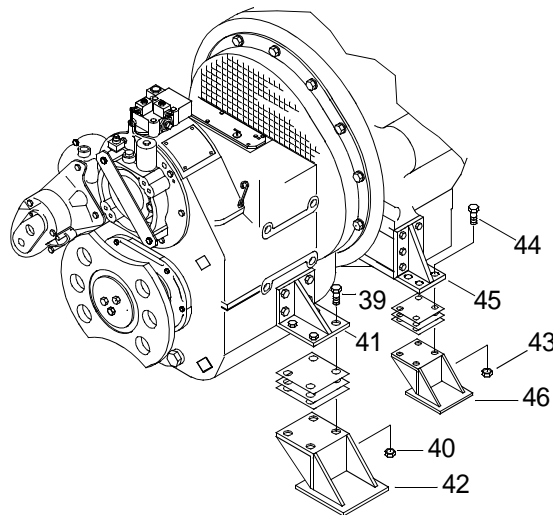

6. Install eight bolts (39) and nuts (40) to secure the two marine gear mounting brackets (41) to the two hull mounts (42) and tighten nuts (40).

7. Remove shackles and three slings (53) from the three lifting brackets (38) on the engine and the chain hoist (52) and sling (54) from the marine gear (55).

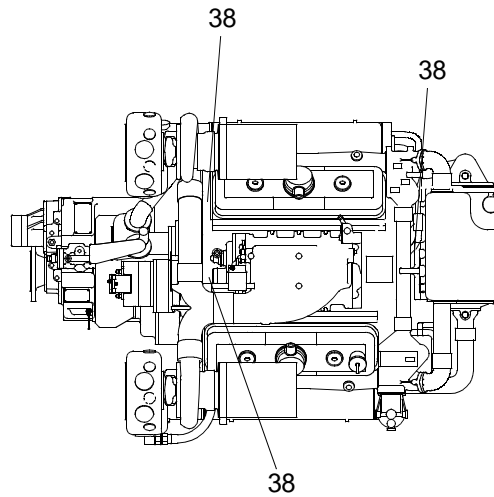

8. Perform engine alignment check. (TM 55-1945-205-24-1-1)
9. Remove twine securing oil filter supply line (35) and oil filter return line (36) outboard.
10. Connect oil filter supply line (35) and oil filter return line (36) to the engine oil cooler (37).

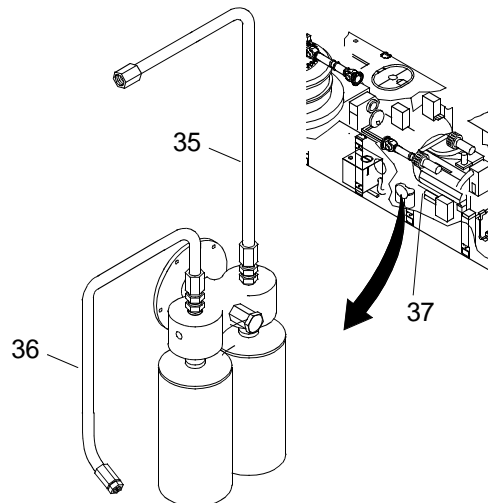

11. Remove twine securing raw water return hose (33).

12. Install two hose clamps (32) securing the raw water return hose (33) from marine gear cooler coupling (34) and tighten hose clamps (35).

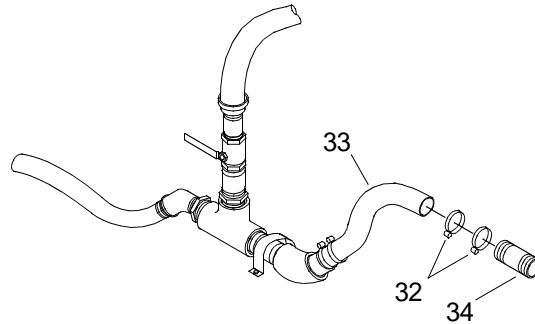

13. Remove twine securing the raw water supply hose (30) outboard.
14. Install two hose clamps (29) securing the raw water supply hose (30) to the raw water pump coupling (31) and tighten clamps (29).

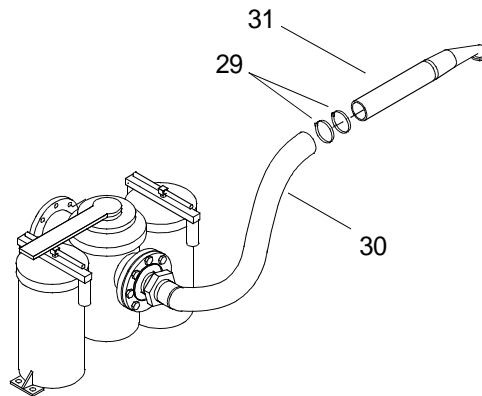

15. Remove twine securing the two selector valves electrical connectors (25) to engine.
16. Install two shifting solenoid electrical connectors (25) on two marine gear selector valve solenoids (26). Remove tags and tighten connectors (25).

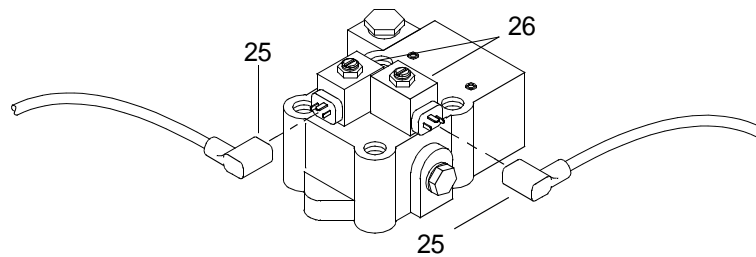

17. Remove twine securing the fuel pump return line (23) to the engine.

WARNING

**CHEMICAL****EYE PROTECTION**

18. Install fuel pump return line (23) on the main fuel return line (24) and tighten fittings on lines (23 and 24).

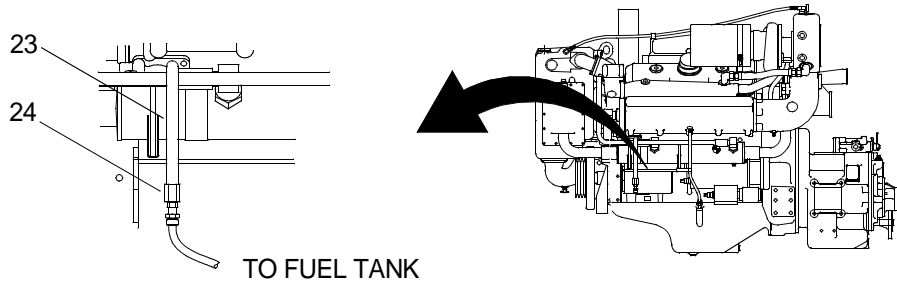

19. Remove twine securing the two supply lines (21 and 22) to the engine.

WARNING

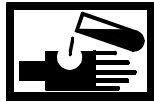
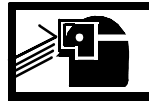
**CHEMICAL****EYE PROTECTION**

20. Install fuel pump supply line (22) on the supply line check valve (20) and tighten fitting on line (22).

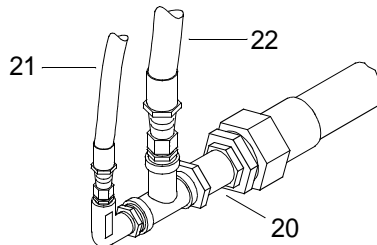

WARNING

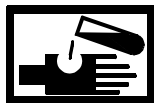
**CHEMICAL****EYE PROTECTION**

21. Install primer pump supply line (21) on supply line check valve (20) and tighten fitting on line (21).
22. Remove twine securing the main engine electrical wire bundle (19) on top of engine.

23. Route main engine electrical wire bundle (19) from engine junction box A4 (18) to engine, securing bundle with tiedown straps as required.

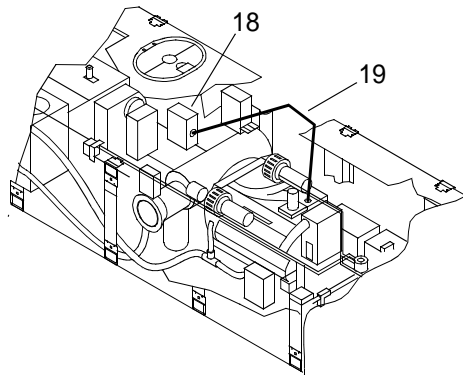

24. Connect main engine electrical wire bundle (19) to engine junction box A4 (18) and remove tags.
25. Remove twine securing two red battery power leads outboard.
26. Route two red battery power leads to the engine and attach to starter solenoid (16) and alternator (17) as tagged.

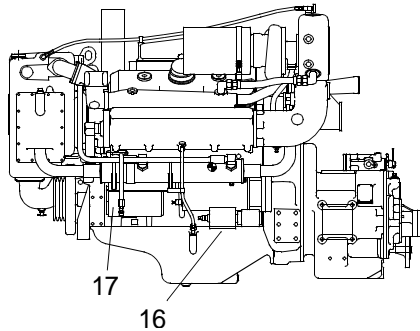

27. Remove tags from red battery power leads.
28. Install tiedown straps on the two red battery power leads as required.
29. Remove twine securing the cold pack starting supply line (14) outboard.

WARNING



EXPLOSION



VAPOR

30. Install cold pack starting supply line (14) on starboard side of air inlet housing (15) and tighten fitting on line (14).

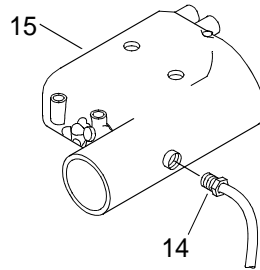

31. Position fire suppression trip mechanism cross-module bracket (13) over engine.

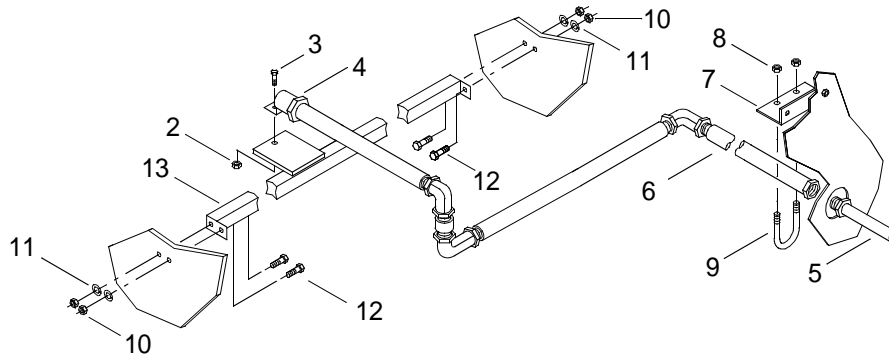

32. Install four bolts (12), lock washers (11) and nuts (10) to secure the cross-module bracket (13) to propulsion module longitudinal frame.
33. Position U-joint bolt (9) beneath the CO2 supply line (6) and install on the propulsion module frame cross-member support bracket (7).
34. Secure U-joint bolt (9) to the propulsion module frame cross-member support bracket (7) with two nuts (8) and tighten nuts.
35. Using a pipe wrench, connect the pipe coupling (5) to the CO2 supply line (6) that feeds the trip mechanism solenoid (4) near the propulsion module frame cross-member support bracket (7).
36. Install one bolt (3) and nut (2) to secure the trip mechanism solenoid (4) to its mount.
37. Discard all removed twine.
38. Install marine gear oil pump. (TM 55-1945-205-24-1-3)
39. Install hydraulic pump. (TM 55-1945-205-24-1-1)
40. Vent hydraulic system. (TM 55-1945-205-24-1-1)
41. Adjust hydraulic system pressure. (TM 55-1945-205-24-1-1)
42. Adjust hydraulic system flow. (TM 55-1945-205-24-1-1)
43. Fill the fresh water cooling system. (WP 0133 00)
44. Install fast lube system. (TM 55-1945-205-24-1-1)
45. Fill engine with crankcase oil. (WP 0115 00)

-
46. Install marine gear to transfer case drive shaft. (TM 55-1945-205-24-1-1)
 47. Install marine gear to transfer case machinery guards. (TM 55-1945-205-24-1-1)
 48. Install exhaust system. (TM 55-1945-205-24-1-1)
 49. Install engine hatch. (TM 55-1945-205-24-1-1)
 50. Install cab or air intake plenum. (TM 55-1945-205-24-1-1)
 51. Install main navigation mast. (TM 55-1945-205-24-1-1)
 52. Install SINCGARS antenna. (TM 11-5820-890-10-8)
 53. Install main batteries negative leads. (TM 55-1945-205-24-1-1)
 54. Prime the fuel system. (WP 0077 00)
 55. Start the engine. (TM 55-1945-205-24-1-1)
 56. Pump the bilges to remove raw water. (TM 55-1945-205-24-1-1)
 57. Check for fuel, oil, fresh water and raw water leaks.
 58. Shut down the engine. (TM 55-1945-205-24-1-1)

WARNING

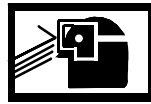
**CHEMICAL****EYE PROTECTION****SLICK FLOOR**

59. Clean up spilled fluid with a spill kit and dispose of spill kit waste in accordance with local procedures.
60. Perform operational check of the diesel engine. (TM 55-1945-205-10-1)

END OF WORK PACKAGE

**GENERAL SUPPORT MAINTENANCE
CAUSEWAY FERRY
ENGINE MAINTENANCE STAND
INSTALLATION AND REMOVAL**

INITIAL SETUP:**Tools**

Tool Kit, General Mechanic's (Item 130, WP 0188 00)
 Stand, Maintenance, Automotive Engine (Item 120, WP 0188 00)
 Adapter, Engine Stand (Item 02, WP 0188 00)
 Qty 2
 Shackle, 3/4 in., 4.75 ton (Item 116, WP 0188 00)
 Qty 3
 Sling 5300 lbs 6 ft (Green) (Item 118, WP 0188 00)
 Qty 3

Personnel Required

Engineer 88L

Equipment Condition

Crankcase Breather Limiter Assembly Removed. (WP 0106 00)
 Air Inlet Collector Assembly Removed. (WP 0104 00)
 Turbochargers Removed. (WP 0114 00)
 Exhaust Manifolds Removed. (WP 0163 00)
 Marine Gear Oil Cooler Removed. (TM 55-1945-205-24-1-3)
 Marine Gear Oil Cooler Mounting Bracket Removed. (WP 0164 00)
 Fuel System Cooler Removed. (WP 0081 00)
 Air Box Covers Removed. (WP 0035 00)
 Air Box Drains Removed. (WP 0036 00)
 Starting Motor Removed. (WP 0170 00)
 Lube Oil Dipstick Tube Assembly Removed. (WP 0130 00)
 Overspeed Governor Removed. (WP 0175 00)
 Lube Oil Cooler Removed. (WP 0128 00)

INSTALL ENGINE ON STAND

1. Install engine stand adaptors (1) on sides of engine (2).

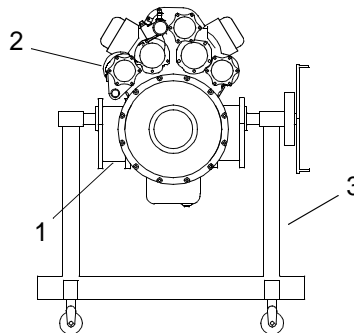

2. Connect lifting slings and shackles to engine (2).

WARNING

**HEAVY PARTS**

3. Using slings and shackles, position engine (2) on engine stand (3),
4. Connect engine stand adaptors (1) to engine stand (3).
5. Disconnect lifting slings and shackles from engine (2).

REMOVE ENGINE FROM STAND

1. Connect lifting slings and shackles to engine (2).
2. Disconnect engine stand adaptors (1) from engine stand (3).

WARNING

**HEAVY PARTS**

3. Using lifting slings and shackles, remove engine (2) from engine stand (3).
4. Remove adaptors (1) from engine (2).
5. Install lube oil cooler. (WP 0128 00)
6. Install overspeed governor. (WP 0175 00)
7. Install lube oil dipstick tube assembly. (WP 0130 00)
8. Install starting motor. (WP 0170 00)
9. Install air box drains. (WP 0036 00)
10. Install air box covers. (WP 0035 00)
11. Install fuel system cooler. (WP 0081 00)
12. Install marine gear oil cooler mounting bracket. (WP 0164 00)
13. Install marine gear oil cooler. (TM 55-1945-205-24-1-3)
14. Install exhaust manifolds. (WP 0163 00)
15. Install turbochargers. (WP 0114 00)
16. Install air inlet collector assembly. (WP 0104 00)
17. Install crankcase breather limiter assembly. (WP 0106 00)

END OF WORK PACKAGE

**DIRECT SUPPORT MAINTENANCE
CAUSEWAY FERRY
ENGINE
ALIGNMENT**

INITIAL SETUP:**Tools**

Tool Kit, General Mechanic's (Item 130, WP 0188 00)
Brush, Wire Scratch (Item 21, WP 0188 00)
Shackle, ¾ in., 4.75 ton (Item 116, WP 0188 00)
Qty 3
Sling 5300 lbs 6 ft (Green) (Item 118, WP 0188 00)
Qty 4

Materials/Parts

Shim Set
(34712)
PN E11961
Shim Set
(34712)
PN E11971

Personnel Required

Engineer 88L

References

TM 55-1945-205-24-1-3
TM 55-1945-205-24-1-4

Equipment Condition

SINGARS Antenna Removed. (TM 11-5820-890-10-8)
Main Navigation Mast Removed. (TM 55-1945-205-24-1-1)
Operators Cab Removed. (TM 55-1945-205-24-1-1)
Intake Plenum Removed. (TM 55-1945-205-24-1-1)
Exhaust Plenum Removed. (TM 55-1945-205-24-1-1)
Engine Hatch Removed. (TM 55-1945-205-24-1-1)
Thruster Hatch Removed. (TM 55-1945-205-24-1-1)
Transfer Case To Pump-Jet Machinery Guard Removed. (TM 55-1945-205-24-1-1)
Marine Gear To Transfer Case Machinery Guard Removed. (TM 55-1945-205-24-1-1)

ALIGN ENGINE

WARNING**HEAVY OBJECTS**

Use appropriate crane and lifting device when handling or moving engine, marine gear and transfer case. Failure to do so could result in serious injury to personnel.

NOTE

This task is typical for both port and starboard engines.

1. Using a crane and sling, support the weight of the engine.
2. Prior to securing the engine to the deck, insert shims under the engine pedestal mounts to raise or lower the elevation to the measurements depicted below.

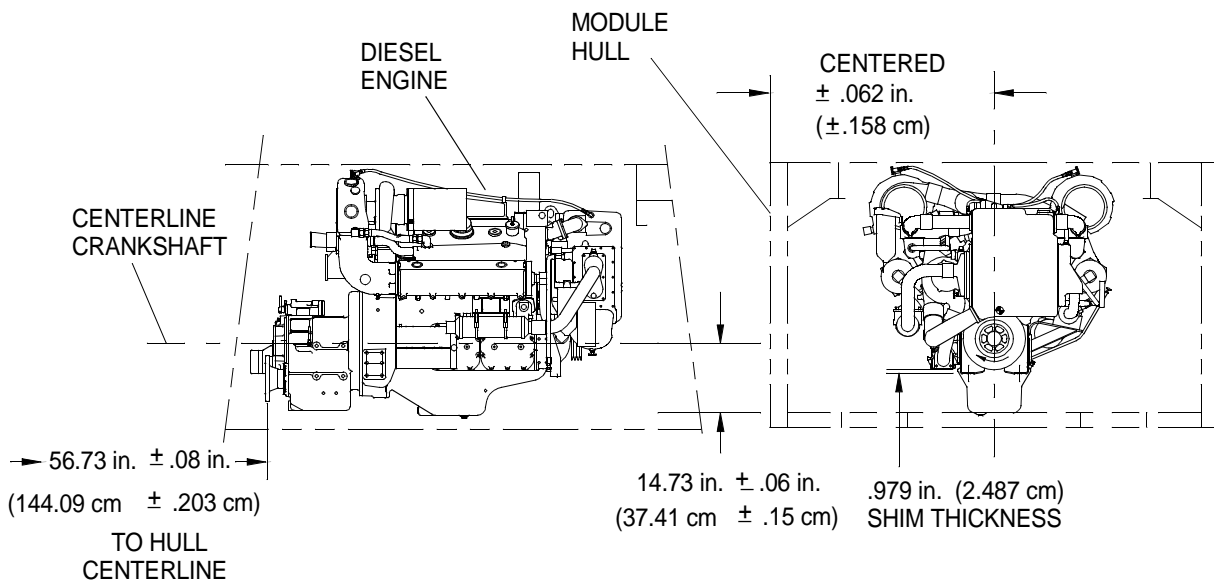

3. Verify that the diesel engine's centerline is parallel, level and square to within $\pm 0.062 \text{ in.}$ of the hull's longitudinal centerline.
4. After engine is aligned, remove sling.
5. Align marine gear. (TM 55-1945-205-24-1-3)
6. Verify that the transfer case input and output flanges are in line with the marine gear and pump-jet.
7. Shim the transfer case in the same manner as the engine to the elevation shown above. (TM 55-1945-205-24-1-4)
8. Verify that the alternator sheave is in line with the engine crank shaft sheave to within $\pm 0.5 \text{ in.}$
9. Install transfer case to pump-jet machinery guard. (TM 55-1945-205-24-1-1)
10. Install marine gear to transfer case machinery guard. (TM 55-1945-205-24-1-1)

-
11. Install the engine hatch. (TM 55-1945-205-24-1-1)
 12. Install the thruster hatch. (TM 55-1945-205-24-1-1)
 13. Install the exhaust plenum. (TM 55-1945-205-24-1-1)
 14. Install the intake plenum. (TM 55-1945-205-24-1-1)
 15. Install the operators cab. (TM 55-1945-205-24-1-1)
 16. Install main navigation mast. (TM 55-1945-205-24-1-1)
 17. Install SINGARS antenna. (TM 11-5820-890-10-8)

END OF WORK PACKAGE

**UNIT LEVEL MAINTENANCE
CAUSEWAY FERRY
AIR BOX
TESTING**

INITIAL SETUP:**Test Equipment**

Manometer, Vertical Tube (Item 82, WP 0188 00)

Tools

Tool Kit, General Mechanic's (Rail and Marine) (Item 131, WP 0188 00)

Personnel Required

Engineer 88L

References

TM 55-1945-205-10-1

Equipment Condition

Engine Cool To Touch.

TEST STARBOARD AIR BOX PRESSURE**NOTE**

Air box pressure should be recorded in inches of mercury using a U-tube manometer.

When using the air box drain as a source for this pressure test, be sure the drain is clean and clear of obstructions.

To check air box pressure on engines with drain tubes or hoses, use air box covers with a tapped hole and hose fitting.

The following procedure is typical for both the port and starboard engines.

1. Remove the air box drain hose (1) from the air box check valve (2).

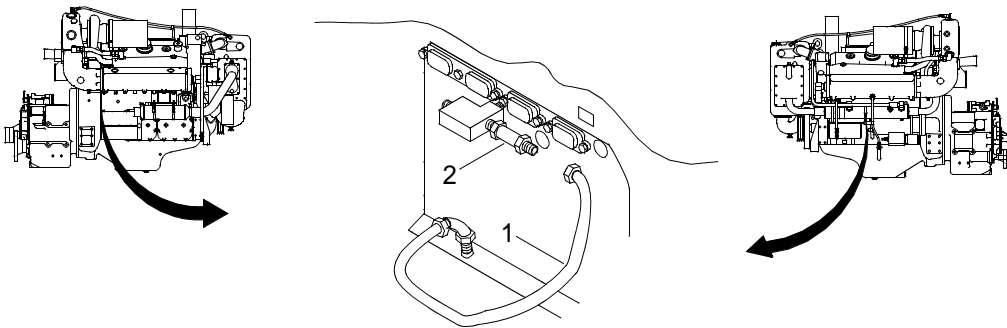

2. Connect manometer tube (3) and manometer (4) to air box check valve (2).

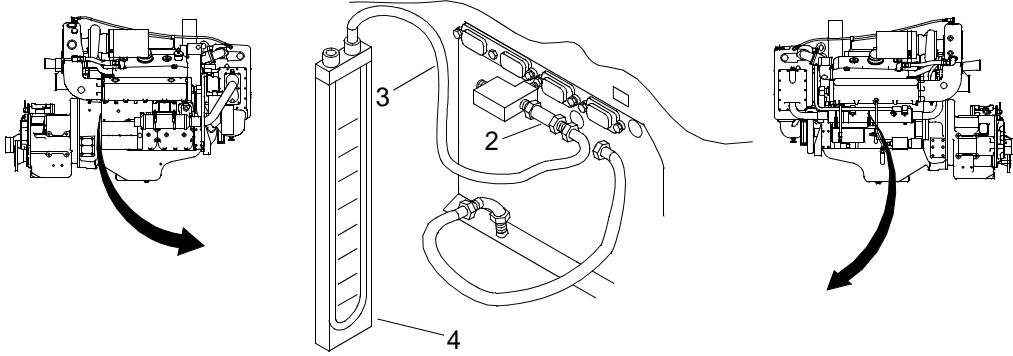

3. Start engine and warm up for 5 minutes. (TM 55-1945-205-10-1)
4. Verify air box pressures to various speeds as follows.
 - a. Ensure that at 1200 RPM, pressure is 9 PSI (62 kPa).
 - b. Ensure that at 1800 RPM, pressure is 16 PSI (110 kPa).
 - c. Ensure that at 1950 RPM, pressure is 20 PSI (138 kPa).
5. Shut off engine. (TM 55-1945-205-10-1)

WARNING



HOT AREA

6. Ensure engine is cool to touch.
7. Remove manometer (4) and manometer tube (3) from air box check valve (2).
8. Connect air box drain hose (1) to air box check valve (2) and tighten fitting.

TEST PORT AIR BOX PRESSURE

NOTE

Air box pressure should be recorded in inches of mercury using a U-tube manometer.

When using the air box drain as a source for this pressure test, be sure the drain is clean and clear of obstructions.

To check air box pressure on engines with drain tubes or hoses, use air box covers with a tapped hole and hose fitting.

The following procedure is typical for both the port and starboard engines.

1. Drain cooling system (WP 0134 00)

2. Remove fuel system cooler. (WP 0081 00)
3. Remove the air box drain hose (1) from the air box check valve (2).

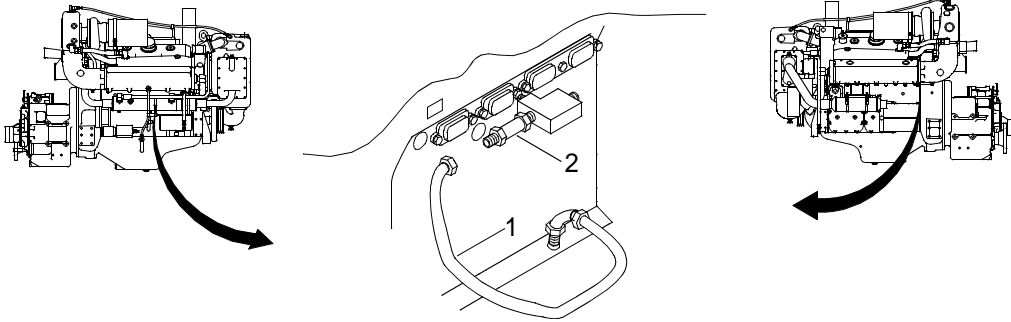

4. Connect manometer tube (3) and manometer (4) to air box check valve (2).

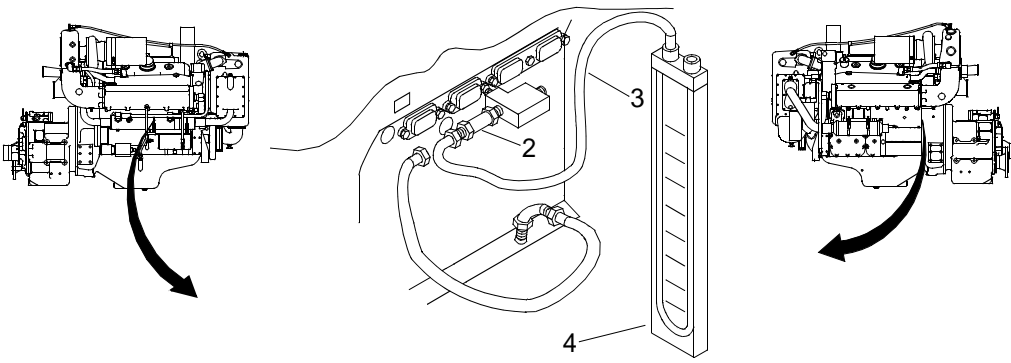

5. Install fuel system cooler. (WP 0081 00)
6. Service cooling system. (WP 0133 00)
7. Start engine and warm up for 5 minutes. (TM 55-1945-205-10-1)
8. Verify air box pressures to various speeds as follows.
 - a. Ensure that at 1200 RPM, pressure is 9 PSI (62 kPa).
 - b. Ensure that at 1800 RPM, pressure is 16 PSI (110 kPa).
 - c. Ensure that at 1950 RPM, pressure is 20 PSI (138 kPa).
9. Shut off engine. (TM 55-1945-205-10-1)

WARNING



HOT AREA

10. Ensure engine is cool to touch.

11. Drain engine cooling system (WP 0134 00)
12. Remove fuel system cooler. (WP 0081 00)
13. Remove manometer (4) and manometer tube (3) from air box check valve (2).
14. Connect air box drain hose (1) to air box check valve (2) and tighten fitting.
15. Install fuel system cooler. (WP 0081 00)
16. Service fresh water cooling system. (WP 0133 00)

END OF WORK PACKAGE

**UNIT LEVEL MAINTENANCE
CAUSEWAY FERRY
AIR BOX COVERS
REMOVAL AND INSTALLATION**

INITIAL SETUP:**Tools**

Tool Kit, General Mechanic's (Rail and Marine) (Item 131, WP 0188 00)
Wrench, Torque (10-250 in. lbs) (Item 141, WP 0188 00)
Wrench Set, Socket (3/8 in. sqdr) (Item 135, WP 0188 00)
Apron, Utility (Item 08, WP 0188 00)
Gloves, Chemical (Item 52, WP 0188 00)
Goggles, Industrial (Item 54, WP 0188 00)

Materials/Parts

Gasket Set
(72582)
NSN 5330-01-056-1111
PN 23512685
Sealing Compound, (Ultra-Blue) (Item 30, WP 0187 00)
Antiseize Compound (Item 6, WP 0187 00)
Cleaner (Item 8, WP 0187 00)
Rags, Wiping (Item 28, WP 0187 00)

Personnel Required

Engineer 88L

References

TM 55-1945-205-10-1
TM 55-1945-205-24-1-3

Equipment Condition

Engine Cool To Touch.

REMOVE STARBOARD AIR BOX COVERS**NOTE**

The following procedure is typical for the removal and installation of air box covers on both port and starboard engines.

1. Remove marine gear cooler. (TM 55-1945-205-24-1-3)

- Remove seven screws (1) securing two single air box drain covers (2) and one double air box drain cover (3) to side of engine block (4).

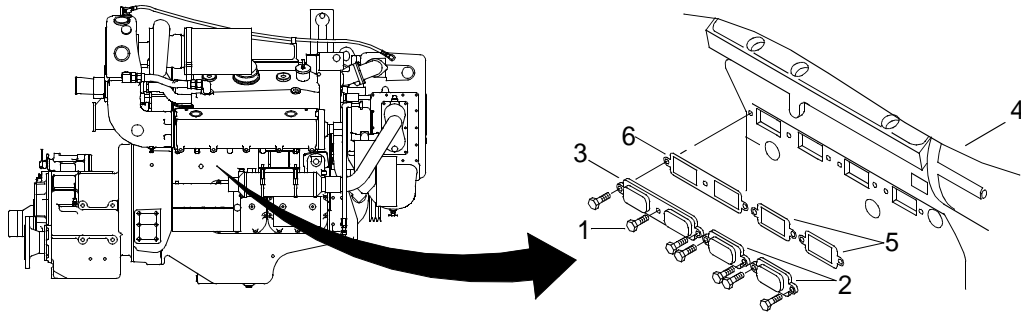

- Remove three air box drain covers (2, 3) and two single gaskets (5) and one double (6) gasket. Discard all gaskets (5, 6).
- Using a putty knife, remove old gasket material from air box drain covers (2, 3) and engine block (4) mating surfaces.

WARNING



CHEMICAL



EYE PROTECTION

- Using cleaner and wiping rags, ensure mating surfaces are free of all debris.

REMOVE PORT AIR BOX COVERS

NOTE

The following procedure is typical for the removal and installation of air box drain covers on both starboard and port engines.

- Remove fuel system cooler. (WP 0081 00)
- Remove seven screws (1) securing two single air box covers (2) and one double air box cover (3) to side of engine block (4).

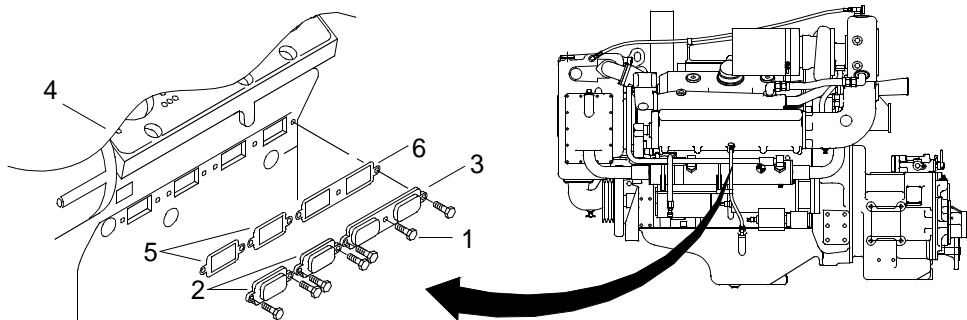

- Remove three air box covers (2, 3) and two single (5) gaskets and one double (6) gasket. Discard all gaskets (5, 6).
- Using a putty knife, remove old gasket material from air box covers (2, 3) and engine block (4) mating surfaces.

WARNING

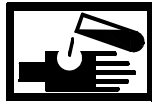
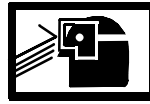
**CHEMICAL****EYE PROTECTION**

- Using cleaner and wiping rags, ensure mating surfaces are free of all debris.

INSTALL STARBOARD AIR BOX COVERS

WARNING

**CHEMICAL****EYE PROTECTION**

- Coat two new single gaskets (5) and one new double gasket (6) with sealing compound.

WARNING

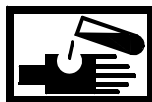
**CHEMICAL****EYE PROTECTION**

- Coat seven hex head screws (1) with antiseize compound.
- Position the air box covers (2, 3) and gaskets (5, 6) on side of engine block (4).
- Install seven hex head screws (1) to secure air box covers (2, 3) and gaskets (5, 6) to side of engine block (4).
- Using torque wrench and socket set, torque screws (1) to 96 - 144 in. lb (11 - 16 N-m).
- Install marine gear cooler. (TM 55-1945-205-24-1-3)

INSTALL PORT AIR BOX COVERS

WARNING

**CHEMICAL****EYE PROTECTION**

- Coat two new single gaskets (5) and one new double gasket (6) with sealing compound.

WARNING

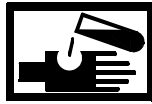
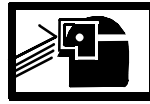
**CHEMICAL****EYE PROTECTION**

2. Coat seven hex head screws (1) with antiseize compound.
3. Position the air box covers (2, 3) and gaskets (5, 6) on side of engine block (4).
4. Install seven hex head screws (1) to secure air box covers (2, 3) and gaskets (5, 6) to side of engine block (4).
5. Using torque wrench and socket set, torque screws (1) to 96 - 144 in. lb (11 - 16 N-m).
6. Install fuel system cooler. (WP 0081 00)
7. Perform operational check of diesel engine. (TM 55-1945-205-10-1)

END OF WORK PACKAGE

**UNIT LEVEL MAINTENANCE
CAUSEWAY FERRY
AIR BOX DRAINS
REMOVAL, CLEANING, INSPECTION AND INSTALLATION**

INITIAL SETUP:**Tools**

Tool Kit, General Mechanic's (Rail and Marine) (Item 131, WP 0188 00)
 Apron, Utility (Item 8, WP 0188 00)
 Gloves, Chemical (Item 52, WP 0188 00)
 Goggles, Industrial (Item 54, WP 0188 00)
 Compressor Unit, Reciprocating, Power Drive (Item 27, WP 0188 00)

Materials/Parts

Cleaner (Item 8, WP 0187 00)
 Tape, Antiseizing (Item 34, WP 0187 00)

Personnel Required

Engineer 88L

References

TM 55-1945-205-10-1

Equipment Condition

Engine Cool To Touch.
 Fresh Water Cooling System Drained (WP 0134 00)
 Fuel System Cooler Removed. (WP 0081 00)

REMOVE AIR BOX DRAIN ASSEMBLIES**NOTE**

The following procedure is typical for both port and starboard engines.

1. Loosen female fitting (1) of hose assembly (2) from the check valve (3).

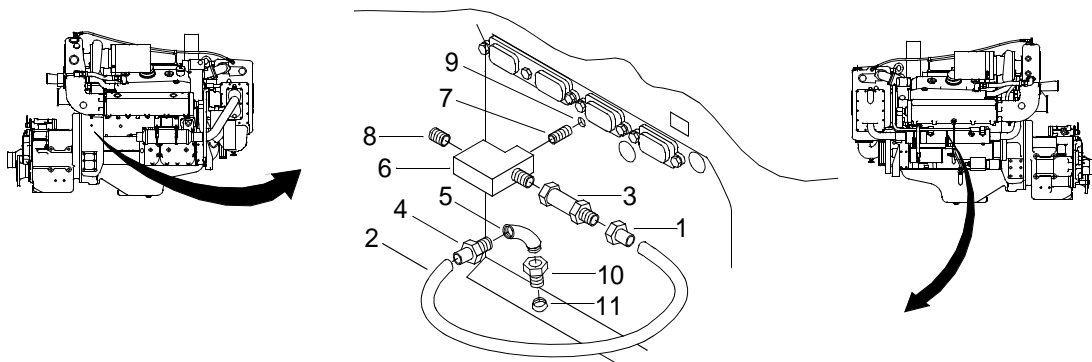

2. Loosen male fitting (4) from 90° elbow fitting (5).
3. Remove hose assembly (2).
4. Remove check valve (3) from tee fitting (6).
5. Remove tee fitting (6) from nipple fitting (7).

6. Remove pipe plug (8) from tee fitting (6).
7. Remove nipple fitting (7) from air box drain opening (9).
8. Remove 90° elbow fitting (5) from female fitting (10).
9. Remove female fitting (10) and bushing (11).

CLEAN AIR BOX DRAIN ASSEMBLIES

WARNING

**CHEMICAL****EYE PROTECTION**

1. Clean air box drains with cleaner.

WARNING

**EYE PROTECTION**

**Do not exceed 40 PSI (276 kPa) when using compressed air for drying components.
Failure to comply could result in serious injury to personnel**

2. Using air compressor, dry all assemblies thoroughly.

INSPECT AIR BOX DRAIN ASSEMBLIES

NOTE

Repair of air box drain is limited to replacement of hose assembly, check valve, tee fitting and pipe fittings.

1. Inspect hose assembly (2) for cracking and deterioration. Replace defective part.
2. Inspect all fittings for corrosion and cracking. Replace defective part.
3. Check all fitting threads for cracking, corrosion and/or galled threads. Replace defective part.

INSTALL AIR BOX DRAIN ASSEMBLIES

WARNING

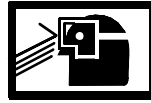
**CHEMICAL****EYE PROTECTION**

1. Apply antiseize tape to all fitting threads.
2. Install bushing (11) into engine block.
3. Install female fitting (10) into bushing (11).
4. Install 90° elbow fitting (5) into female fitting (10).
5. Install nipple fitting (7) and tee fitting (6) into air box drain opening (9).
6. Install pipe plug (8) into tee fitting (6).
7. Install check valve (3) onto tee fitting (6).
8. Install male fitting (4) of hose assembly (2) into 90° elbow fitting (5).
9. Install female fitting (1) of hose assembly (2) onto check valve (3).
10. Tighten all fittings.
11. Install fuel system cooler. (WP 0081 00)
12. Fill fresh water cooling system. (WP 0133 00)
13. Perform operational check of diesel engine. (TM 55-1945-205-10-1)

END OF WORK PACKAGE

**UNIT LEVEL MAINTENANCE
CAUSEWAY FERRY
ENGINE BLOCK AIR BOX DRAIN HOSE
REPLACEMENT**

INITIAL SETUP:**Tools**

Tool Kit, General Mechanic's (Rail and Marine) (Item 131, WP 0188 00)

Materials/Parts

Hose, Non-Metallic
(72582)
NSN 4720-00-274-1154
PN 5113689

Personnel Required

Engineer 88L

References

TM 55-1945-205-10-1

Equipment Condition

Engine Cool To Touch.
Fresh Water Cooling System Drained (WP 0134 00)
Fuel System Cooler Removed. (WP 0081 00)

REMOVE AIR BOX DRAIN HOSE**NOTE**

The following task is typical for both the port and starboard engine air box drains.

1. Remove hose fitting (1) from check valve (2).

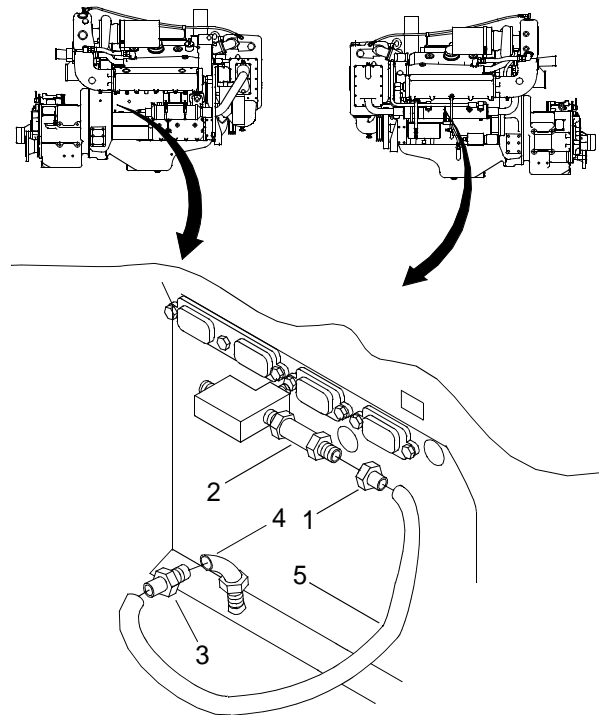

2. Remove hose fitting (3) from fitting (4).
3. Remove drain hose (5).
4. Remove fitting (1) from drain hose (5).
5. Remove fitting (3) from drain hose (5).
6. Discard hose (5).

INSTALL AIR BOX DRAIN HOSE

1. Install fitting (3) in new drain hose (5).
2. Install fitting (1) in new drain hose (5).
3. Install hose fitting (1) on check valve (2).
4. Install hose fitting (3) on fitting (4).
5. Install fuel system cooler. (WP 0081 00)
6. Fill fresh water cooling system. (WP 0133 00)
7. Perform operational check of diesel engine. (TM 55-1945-205-10-1)

END OF WORK PACKAGE

**GENERAL SUPPORT MAINTENANCE
CAUSEWAY FERRY
REAR CYLINDER BLOCK PLATE
REMOVAL AND INSTALLATION**

INITIAL SETUP:**Tools**

Tool Kit, General Mechanic's
(Item 130, WP 0188 00)
Gloves, Chemical (Item 52, WP 0188 00)
Goggles, Industrial (Item 54, WP 0188 00)
Wrench, Torque (0-175 ft lbs)
(Item 138, WP 0188 00)
Wrench, Torque (150-750 in. lbs)
(Item 142, WP 0188 00)
Wrench Set, Socket (3/8 in. sqdr.)
(Item 135, WP 0188 00)

Materials/Parts

Gasket
(72582)
NSN 5330-01-088-5982
PN 8923791
Sealing Compound, (Ultra-Blue)
(Item 30, WP 0187 00)

Personnel Required

Engineer 88L

Equipment Condition

Crankcase Breather Limiter Removed.
(WP 0106 00)
Air Inlet Collector Assembly Removed.
(WP 0104 00)
Turbochargers Removed. (WP 0114 00)
Exhaust Manifolds Removed. (WP 0163 00)
Marine Gear Oil Cooler Removed.
(TM 55-1945-205-24-1-3)
Marine Gear Oil Cooler Mounting Bracket
Removed. (WP 0164 00)
Fuel System Cooler Removed. (WP 0081 00)

Equipment Condition (Cont'd)

Air Box Covers Removed. (WP 0035 00)
Air Box Drains Removed. (WP 0036 00)
Starting Motor Removed. (WP 0170 00)
Lube Oil Dipstick Tube Assembly Removed.
(WP 0130 00)
Overspeed Governor Removed. (WP 0175 00)
Lube Oil Cooler Removed. (WP 0128 00)
Engine Installed On Stand. (WP 0032 00)
Poppet Valve Rocker Arm Covers Removed.
(WP 0043 00)
Water Pump Bypass Hoses Removed.
(WP 0148 00)
Fuel Pump Removed. (WP 0094 00)
Air Intake Housing Removed. (WP 0103 00)
Blower Drive Shaft Removed. (WP 0109 00)
Electronic Governor Rod Assembly Removed.
(WP 0097 00)
Electronic Governor Actuator Removed.
(WP 0098 00)
Blower Removed. (WP 0110 00)
Blower Drive Removed. (WP 0112 00)
Electrical System Hour Meter Removed.
(WP 0167 00)
Electrical System Hour Meter Bracket Removed.
(WP 0168 00)
Raw Water Pump Removed. (WP 0160 00)
Electronic Governor Magnetic Pick-up Removed.
(WP 0100 00)
Oil Pan Removed (WP 0127 00)
Flywheel Removed. (WP 0069 00)
Flywheel Housing Removed (WP 0071 00)
Rear Crankshaft Oil Seal Removed. (WP 0061 00)
Camshaft Gears Removed. (WP 0064 00)
Camshaft Idler Gear Removed. (WP 0067 00)

REMOVE REAR END PLATE

1. Remove three hex head screws (1), special washers (2) and dummy bearing (3) from rear end plate (4).

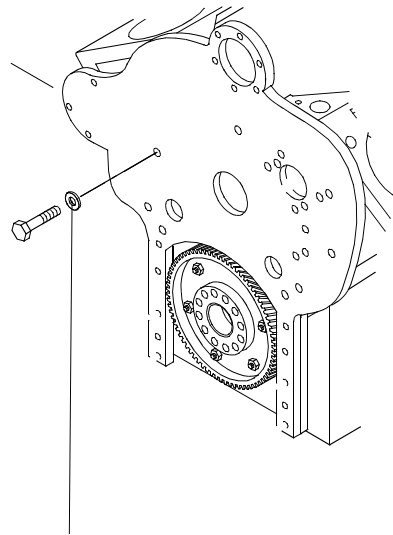

2. Remove six cap screws (5) and lock washers (6) from two cam bearings (7).
3. Remove two cam bearings (7) from rear end plate (4).
4. Remove hex head screw (8) and lock washers (9) from rear end plate (4).
5. Remove four hex head screws (10) and lock washers (11) from rear end plate (4).
6. Remove rear end plate (4) and gasket (12) from engine block (13) and discard gasket (12).

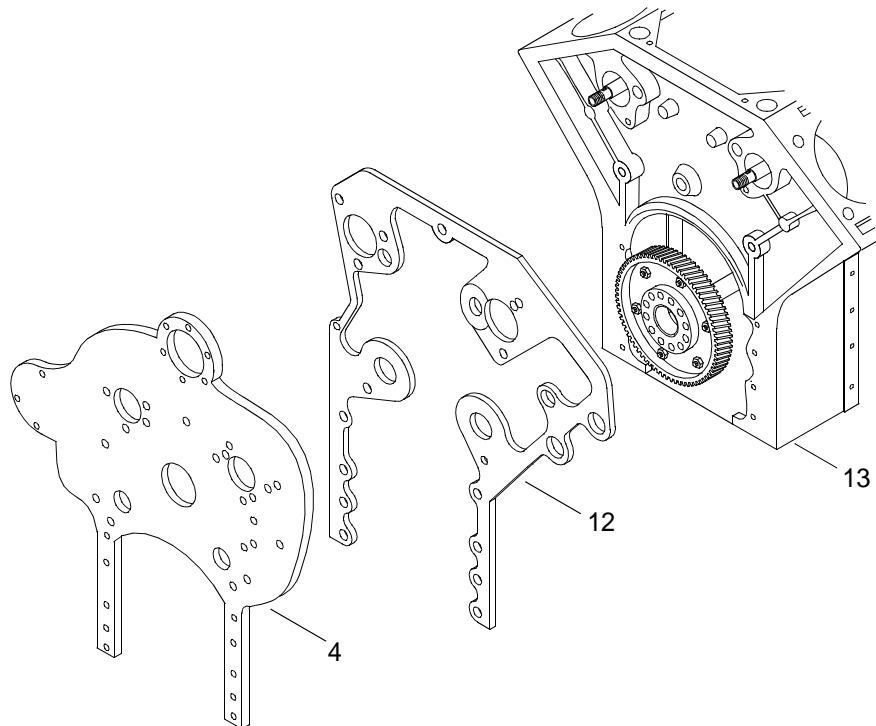

INSTALL REAR END PLATE

WARNING



CHEMICAL



EYE PROTECTION

1. Coat rear end plate (4) and engine block (13) with sealing compound.

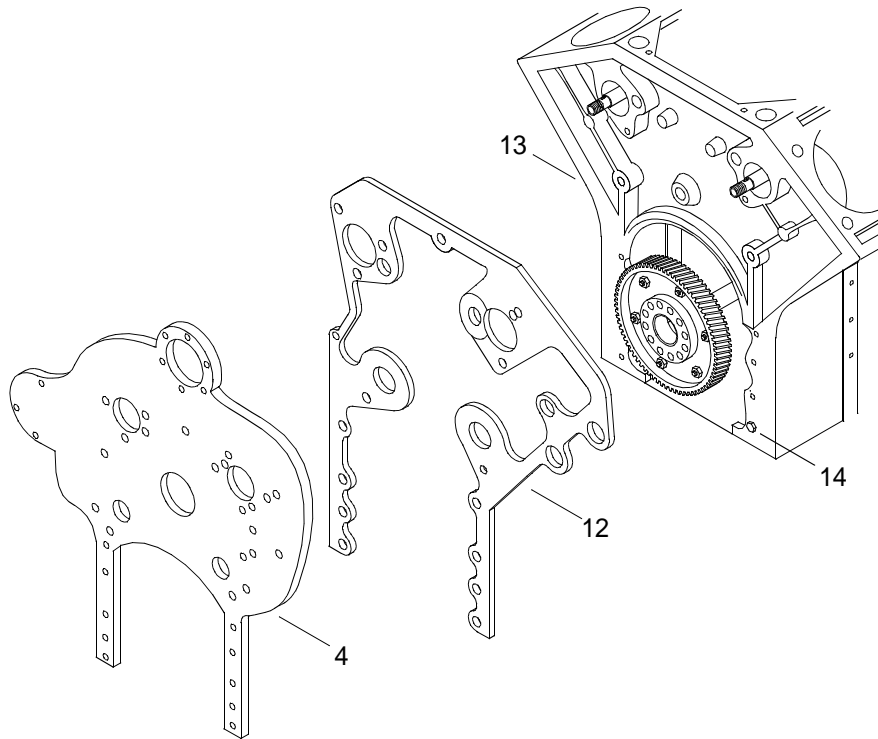

2. Install new gaskets (12) on engine block (13) over dowel pins (14).
3. Install rear end plate (4) on engine block (13).
4. Install four hex head screws (10) and lock washers (11) in rear end plate (4) finger tight.

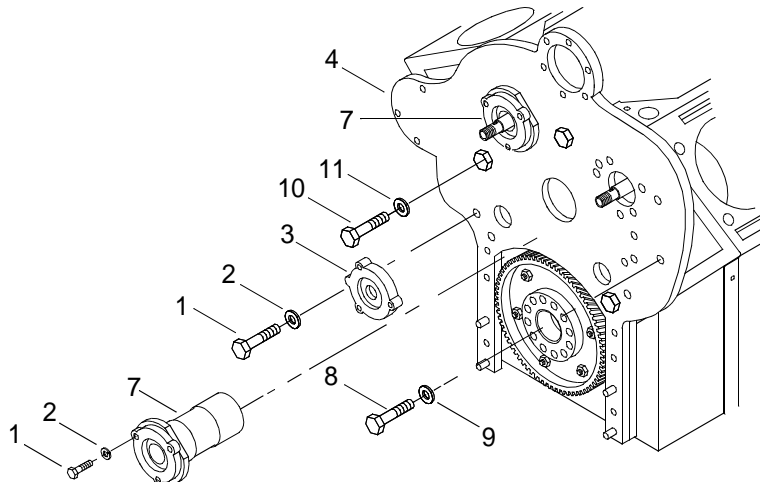

-
5. Install hex head screw (8) and lock washers (9) in rear end plate (4) finger tight.

NOTE

The grooved side of the washer (2) must face the head of screw (1).

6. Install cam bearing (7) on rear end plate (4).
7. Install special washer (5) and hex head screw (6) on cam bearing (7).
8. Install right hand dummy bearing (3) on end plate (4).
9. Install three cap screws (1) and lock washers (2) on dummy bearing (3).
10. Using a torque wrench and socket set, torque hex head screws (10) to 420 in. lbs (47 N-m).
11. Using a torque wrench, torque hex head screws (8) to 110 ft lbs (149 N-m).
12. Using a torque wrench and socket set, torque hex head screws (5) to 480 in. lbs (54 N-m).
13. Using a torque wrench, torque hex head screws (1) to 90 ft lbs (122 N-m).
14. Install camshaft idler gear. (WP 0067 00)
15. Install camshaft gears. (WP 0064 00)
16. Install rear crankshaft oil seal. (WP 0061 00)
17. Install flywheel housing. (WP 0071 00)
18. Install flywheel. (WP 0069 00)
19. Install oil pan (WP 0127 00)
20. Install electronic governor magnetic pick-up. (WP 0100 00)
21. Install raw water pump. (WP 0160 00)
22. Install hour meter bracket. (WP 0168 00)
23. Install hour meter. (WP 0167 00)
24. Install blower drive. (WP 0112 00)
25. Install blower. (WP 0110 00)
26. Install electronic governor actuator. (WP 0098 00)
27. Install electronic governor actuator linkage. (WP 0097 00)
28. Install blower drive shaft. (WP 0109 00)
29. Install air intake housing. (WP 0103 00)
30. Install fuel pump. (WP 0094 00)

-
31. Install water pump bypass tube. (WP 0148 00)
 32. Install cylinder head poppet valve rocker covers. (WP 0043 00)
 33. Remove engine from stand. (WP 0032 00)
 34. Install lube oil cooler. (WP 0128 00)
 35. Install overspeed governor. (WP 0175 00)
 36. Install lube oil dipstick tube assembly. (WP 0130 00)
 37. Install starting motor.(WP 0170 00)
 38. Install air box drains. (WP 0036 00)
 39. Install air box covers. (WP 0035 00)
 40. Install fuel system cooler. (WP 0081 00)
 41. Install marine gear oil cooler mounting bracket. (WP 0164 00)
 42. Install marine gear oil cooler. (TM 55-1945-205-24-1-3)
 43. Install exhaust manifolds. (WP 0163 00)
 44. Install turbochargers. (WP 0114 00)
 45. Install air inlet collector assembly. (WP 0104 00)
 46. Install crankcase breather limiter. (WP 0106 00)

END OF WORK PACKAGE

**GENERAL SUPPORT MAINTENANCE
CAUSEWAY FERRY
REAR CYLINDER BLOCK PLATE
REPAIR**

INITIAL SETUP:**Tools**

Tool Kit, General Mechanic's (Item 130, WP 0188 00)
Press, Arbor, Hand Operated (Item 97, WP 0188 00)

Materials/Parts

Insert, Screw Thread
(72582)
NSN 5325-00-921-6413
PN 5121459
Qty 10
Cloth, Abrasive (Item 12, WP 0187 00)

Personnel Required

Engineer 88L

REPAIR REAR CYLINDER BLOCK PLATE

1. Inspect the block plate (1) gasket surfaces for scratches, gouges, nicks, dents, cracks or warping.

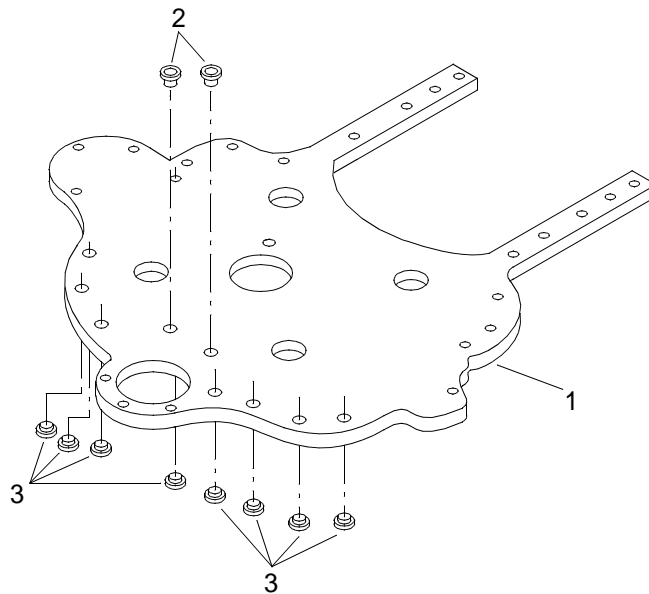

2. Discard any block plate (1) that is warped or cracked.
3. Using 320 grit abrasive cloth, polish out any nicks, dents, scratches or gouges.
4. Discard any block plate (1) that cannot be repaired with abrasive cloth.
5. Support the rear block plate (1) on a flat surface.

WARNING

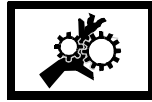
**MOVING PARTS**

6. Using an arbor press, remove two threaded screw inserts (2) from the front side of the block plate (1).

WARNING

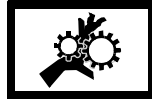
**MOVING PARTS**

7. Using an arbor press, remove eight threaded screw inserts (3) from the back side of the block plate (1).

WARNING

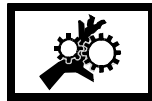
**MOVING PARTS**

8. Using an arbor press, Install two threaded screw inserts (2) in the front side of the block plate (1).

WARNING

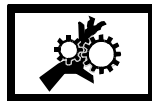
**MOVING PARTS**

9. Using an arbor press, install eight threaded screw inserts (3) in the front side of the block plate (1).

END OF WORK PACKAGE

**GENERAL SUPPORT MAINTENANCE
CAUSEWAY FERRY
FRONT CYLINDER BLOCK PLATE
REMOVAL AND INSTALLATION**

INITIAL SETUP:**Tools**

Tool Kit, General Mechanic's (Item 130, WP 0188 00)
Gloves, Chemical (Item 52, WP 0188 00)
Goggles, Industrial (Item 54, WP 0188 00)
Wrench, Torque (0-175 ft lbs) (Item 138, WP 0188 00)
Wrench, Torque (150-750 in. lbs) (Item 142, WP 0188 00)
Wrench Set, Socket (3/8 in. sqdr.) (Item 135, WP 0188 00)

Materials/Parts

Gasket
(72582)
NSN 5330-01-054-2399
PN 5144901
Sealing Compound, (Ultra-Blue) (Item 30, WP 0187 00)

Personnel Required

Engineer 88L

Equipment Condition

Crankcase Breather Limiter Assembly Removed. (WP 0106 00)
Air Inlet Collector Assembly Removed. (WP 0104 00)
Turbochargers Removed. (WP 0114 00)
Exhaust Manifolds Removed. (WP 0163 00)
Marine Gear Oil Cooler Removed. (TM 55-1945-205-24-1-3)
Marine Gear Oil Cooler Mounting Bracket Removed. (WP 0164 00)
Fuel System Cooler Removed.(WP 0081 00)
Air Box Drains Removed. (WP 0036 00)
Air Box Covers Removed. (WP 0035 00)
Starting Motor Removed. (WP 0170 00)
Lube Oil Dipstick Tube Removed.(WP 0130 00)
Overspeed Governor Removed. (WP 0175 00)
Lube Oil Cooler Removed. (WP 0128 00)
Engine Mounted On Stand. (WP 0032 00)
Fresh Water Cooling System Heat Exchanger Removed. (WP 0138 00)
Forward Lifting Bracket Removed. (WP 0139 00)
Fresh Water Cooling System Filter Removed. (WP 0140 00)
Fresh Water Cooling System Filter Cover Removed. (WP 0141 00)
Fresh Water Cooling System Filter Head Mounting Bracket Removed. (WP 0142 00)
Fresh Water Pump Removed.(WP 0153 00)
Camshaft Accessory Drive Pulley Removed. (WP 0066 00)
Vibration Damper Removed. (WP 0074 00)
Front Balance Weight Cover Removed. (WP 0075 00)
Fresh Water Pump Drive Gear Removed. (WP 0153 00)

REMOVE FRONT CYLINDER BLOCK PLATE

1. Remove six cap screws (1) and lock washers (2) securing two cam bearings (3) to front block plate (4).

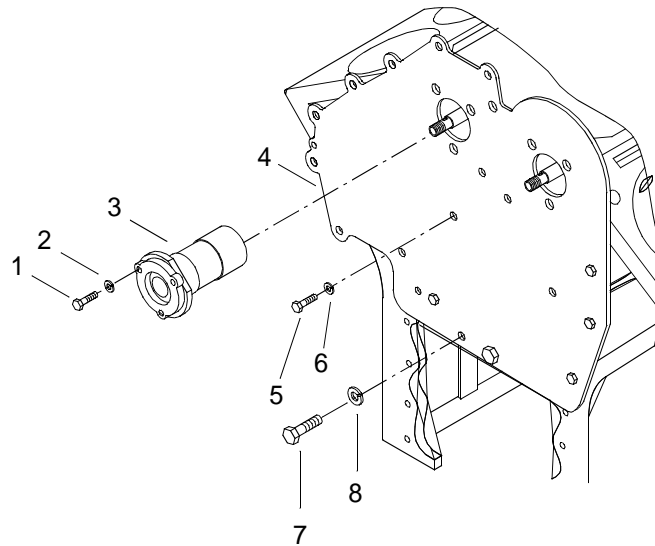

2. Remove two cam bearings (3) from front block plate (4).
3. Position five hex head screws (5) and lock washers (6) from front block plate (4).
4. Remove two hex head screws (7) and lock washers (8) from front block plate (4).
5. Remove front block plate (4) and gaskets (9 and 10) from engine block (11). Discard gaskets (9 and 10).

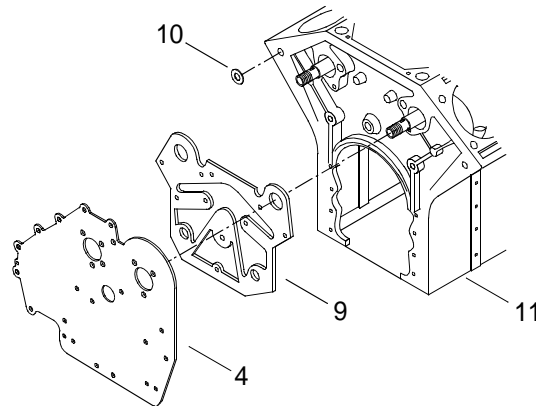

INSTALL FRONT CYLINDER BLOCK PLATE

WARNING

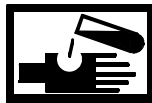

CHEMICAL



EYE PROTECTION

1. Coat front block plate (4) and engine block (11) with sealing compound.

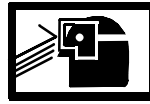
WARNING**CHEMICAL****EYE PROTECTION**

2. Install new gaskets (9 and 10) on engine block (11).

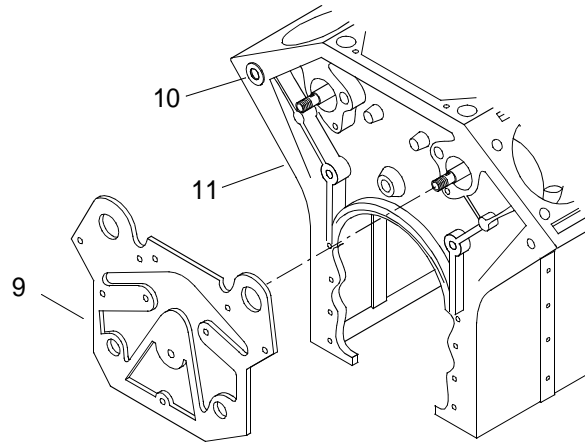

3. Install front block plate (4) on engine (11).

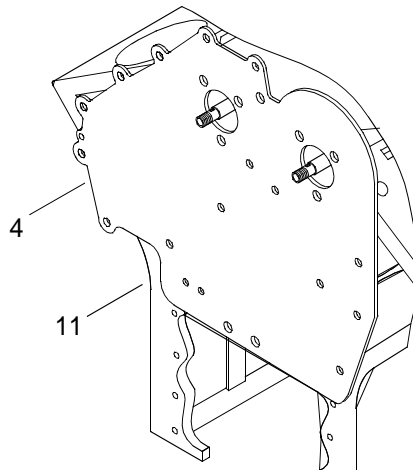

4. Install two hex head screws (7) and lock washers (8) in front block plate (4) finger tight.

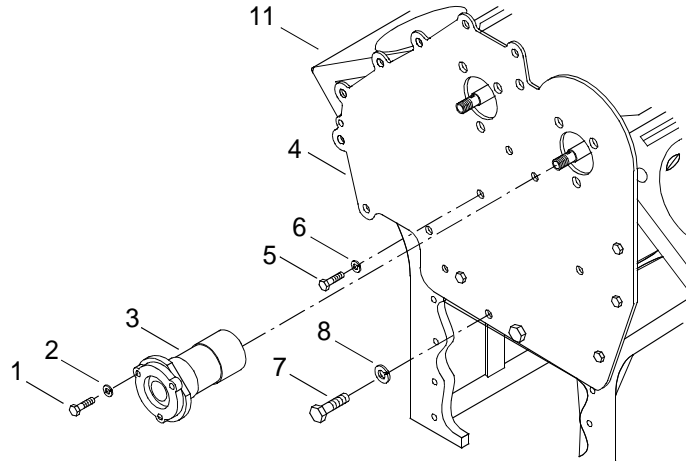

5. Install five hex head screws (5) and lock washers (6) in front block plate (4) finger tight.

NOTE

The smaller right hand camshaft bearing shall be used as a pilot while aligning the front block plate on the engine block.

6. Install two cam shaft end bearings (3) into front block plate (4).
7. Install six cap screws (1) and lock washers (2) securing camshaft bearings (3) to front block plate (4).
8. Using torque wrench and socket set, torque six cap screws (1) to 480 in. lbs (54 N-m).
9. Using torque wrench and socket set, torque hex head screws (5) to 420 in. lbs (47 N-m).
10. Using torque wrench, torque hex head screws (7) to 75 ft lbs (102 N-m).
11. Install fresh water pump drive gear. (WP 0153 00)
12. Install front balance weight cover. (WP 0076 00)
13. Install vibration damper. (WP 0074 00)
14. Install camshaft drive accessory pulley. (WP 0066 00)
15. Install fresh water pump. (WP 0152 00)
16. Install fresh water cooling system filter head mounting bracket. (WP 0142 00)
17. Install fresh water cooling system filter cover. (WP 0141 00)
18. Install fresh water cooling system filter element. (WP 0140 00)
19. Install forward lifting bracket. (WP 0139 00)
20. Install fresh water cooling system heat exchanger. (WP 0138 00)
21. Remove engine from stand. (WP 0032 00)

-
22. Install lube oil cooler. (WP 0128 00)
 23. Install overspeed governor. (WP 0175 00)
 24. Install lube oil dipstick tube. (WP 0130 00)
 25. Install starting motor. (WP 0170 00)
 26. Install air box drains. (WP 0036 00)
 27. Install air box covers. (WP 0035 00)
 28. Install fuel system cooler. (WP 0081 00)
 29. Install marine gear oil cooler mounting bracket. (WP 0164 00)
 30. Install marine gear oil cooler. (TM 55-1945-205-24-1-3)
 31. Install exhaust manifolds. (WP 0163 00)
 32. Install turbochargers. (WP 0114 00)
 33. Install air inlet collector assembly. (WP 0104 00)
 34. Install crankcase breather limiter assembly. (WP 0106 00)

END OF WORK PACKAGE

**GENERAL SUPPORT MAINTENANCE
CAUSEWAY FERRY
FRONT CYLINDER BLOCK PLATE
REPAIR**

INITIAL SETUP:**Tools**

Tool Kit, General Mechanic's (Item 130, WP 0188 00)
Press, Arbor, Hand Operated (Item 97, WP 0188 00)

Materials/Parts

Insert, Screw Thread
(72582)
NSN 5325-00-921-6413
PN 5121459
Cloth, Abrasive, 320 Grit (Item 12, WP 0187 00)

Personnel Required

Engineer 88L

REPAIR FRONT CYLINDER BLOCK PLATE

1. Inspect cylinder block plate (1) gasket surfaces for scratches, gouges, nicks, dents, cracks or warping. Discard cylinder block plate that is cracked or warped.

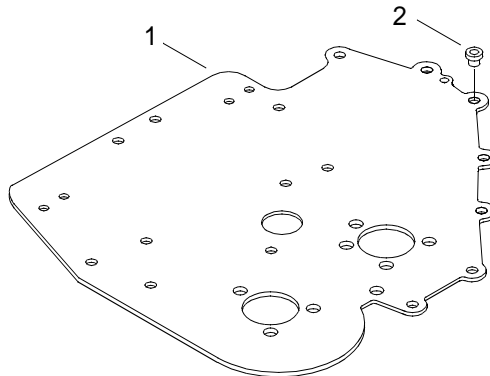

2. Polish out any nicks, dents, scratches or gouges using 320 grit abrasive cloth. Discard cylinder block plate if nicks, dents, scratches or gouges can not be removed using 320 grit abrasive cloth.
3. Support cylinder block plate (1) on a flat surface.

WARNING

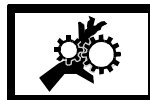

MOVING PARTS

4. Using an arbor press, remove threaded screw insert (2) from front side of cylinder block plate (1).

WARNING



MOVING PARTS

5. Using an arbor press, install threaded screw insert (2) into front side of cylinder block plate (1).

END OF WORK PACKAGE

**GENERAL SUPPORT MAINTENANCE
CAUSEWAY FERRY
ENGINE BLOCK
REPAIR**

INITIAL SETUP:**Tools**

Tool Kit, General Mechanic's
(Item 130, WP 0188 00)
Wrench, Torque (0-175 ft lbs)
(Item 138, WP 0188 00)
Wrench, Torque (10-250 in. lbs)
(Item 141, WP 0188 00)
Wrench, Torque (150-750 in. lbs)
(Item 142, WP 0188 00)
Wrench Set, Socket (3/8 in. sqdr.)
(Item 135, WP 0188 00)
Wrench, Torque (100-600 ft lbs)
(Item 139, WP 0188 00)
Hammer, Hand, (Dead Blow)
(Item 59, WP 0188 00)
Installer and Remover, Plug (Item 71, WP 0188 00)
Installer and Remover, Inlet Adaptor
(Item 70, WP 0188 00)
Gage, Cylinder (Counterbore Depth Gauge)
(Item 43, WP 0188 00)
Setting, Master, Dial Bore Gauge
(Item 114, WP 0188 00)
Testing Kit, Cylinder Block Pressure, Service
(Item 126, WP 0188 00)
Apron, Utility (Item 8, WP 0188 00)
Gloves, Chemical (Item 52, WP 0188 00)
Goggles, Industrial (Item 54, WP 0188 00)
Respirator, Air Filtering (Item 109, WP 0188 00)
Protectors, Hearing (Item 98, WP 0188 00)

Materials/Parts

Gasket
(72582)
NSN 5330-00-769-4882
PN 5138659
Qty 2

Materials/Parts (Cont'd)

Gasket
(72582)
NSN 5330-01-206-3265
PN 8923792
Plug, Expansion
(72582)
NSN 5340-00-255-4423
PN 5139989
Qty 8
Plug, Expansion
(72582)
NSN 5340-00-231-0941
PN 5132410
Qty 2
Plug, Expansion
(72582)
NSN 5340-00-598-5135
PN 09428477
Qty 1
Oil, Lubricating, Engine, 10W
(Item 25, WP 0187 00)
Sealing Compound, (Pipe Sealant)
(Item 29, WP 0187 00)
Antifreeze (Item 5, WP 0187 00)
Cleaning Compound (Item 10, WP 0187 00)
Boots, Disposable (Item 7, WP 0187 00)

Personnel Required

Engineer 88L

References

TM 55-1945-205-24-1-1
TM 55-1945-205-24-1-3

DISASSEMBLE ENGINE BLOCK

1. Crankcase breather limiter assembly removed. (WP 0106 00)
2. Air inlet collector assembly removed. (WP 0104 00)
3. Air intake housing. (WP 0103 00)
4. Turbochargers removed. (WP 0114 00)
5. Exhaust manifolds removed. (WP 0163 00)

-
6. Marine gear oil cooler removed. (TM 55-1945-205-24-1-3)
 7. Fuel system cooler removed. (WP 0081 00)
 8. Air box drains removed. (WP 0035 00)
 9. Air box covers removed. (WP 0036 00)
 10. Starter motor removed. (WP 0170 00)
 11. Lube oil dipstick tube assembly removed. (WP 0130 00)
 12. Lube oil cooler removed. (WP 0128 00)
 13. Overspeed governor removed. (WP 0175 00)
 14. Mount engine on stand. (WP 0032 00)
 15. Cylinder head poppet valves rocker arm covers removed. (WP 0043 00)
 16. Fresh water cooling system water by-pass hose removed. (WP 0148 00)
 17. Fuel pump removed. (WP 0094 00)
 18. Blower removed. (WP 0110 00)
 19. Blower drive shaft removed. (WP 0109 00)
 20. Blower drive removed. (WP 0112 00)
 21. Electronic governor rod assembly removed. (WP 0097 00)
 22. Electronic governor actuator removed. (WP 0098 00)
 23. Engine block breather pipe removed. (WP 0107 00)
 24. Heat exchanger removed. (WP 0138 00)
 25. Tachometer drive removed. (WP 0174 00)
 26. After cooler removed. (WP 0155 00)
 27. Oil pan removed. (WP 0127 00)
 28. Flywheel removed. (WP 0069 00)
 29. Electrical system hour meter removed. (WP 0167 00)
 30. Electrical system hour meter mounting bracket removed. (WP 0168 00)
 31. Raw water pump removed. (WP 0160 00)
 32. Flywheel housing removed. (WP 0071 00)
 33. Fresh water cooling system starboard thermostat housing removed. (WP 0145 00)

-
34. Fresh water cooling system port thermostat housing removed. (WP 0144 00)
 35. Fresh water cooling system port water outlet manifold removed. (WP 0150 00)
 36. Fresh water cooling system starboard water outlet manifold removed. (WP 0151 00)
 37. Fuel injector control tube removed. (WP 0086 00)
 38. Fuel injector removed. (WP 0091 00)
 39. Cylinder heads removed. (WP 0046 00)
 40. Fresh water cooling system coolant filter element removed. (WP 0140 00)
 41. Fresh water cooling system coolant filter head cover removed. (WP 0141 00)
 42. Fresh water cooling system coolant filter head cover mounting bracket removed. (WP 0142 00)
 43. Water pump removed.(WP 0152 00)
 44. Water pump drive gear removed. (WP 0153 00)
 45. Camshaft accessory pulley removed. (WP 0066 00)
 46. Camshaft vibration damper removed. (WP 0063 00)
 47. Camshafts and bearings removed. (WP 0062 00)
 48. Idler gear removed. (WP 0067 00)
 49. Front balance weight cover removed. (WP 0076 00)
 50. Camshaft balance weight removed. (WP 0065 00)
 51. Front cylinder block plate removed. (WP 0040 00)
 52. Rear cylinder block plate removed. (WP 0038 00)
 53. Oil pressure regulator valve removed. (WP 0123 00)
 54. Oil pressure relief valve removed. (WP 0125 00)
 55. Oil pump removed. (WP 0119 00)
 56. Pistons and cylinder liners removed. (WP 0072 00)
 57. Vibration damper removed. (WP 0074 00)
 58. Crankshaft removed. (WP 0060 00)

WARNING**HEAVY PARTS****EYE PROTECTION****NOTE**

Tag all parts during removal to ensure proper installation.

59. Remove oil galley plugs (1), (2) and (3) from front of engine block (4).

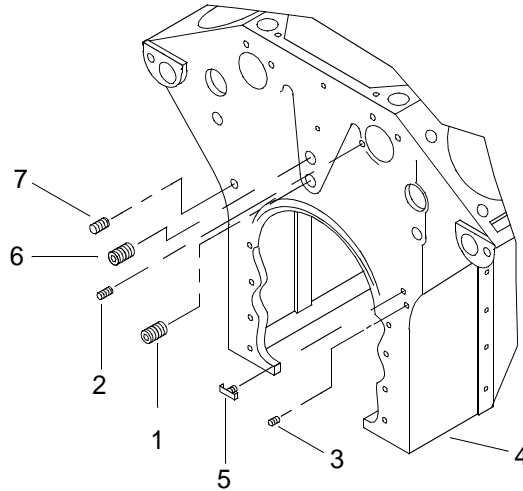

60. Remove drain cock (5).

61. Remove plugs (6) and (7).

62. Remove oil galley plugs (8) and (9) from rear of engine block (4).

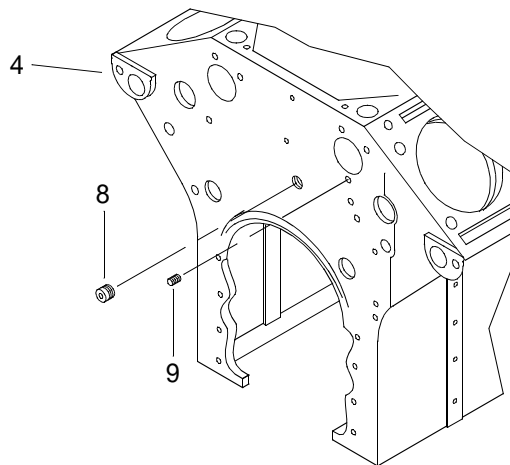

63. Remove two plugs (10) from right side of engine block (4).

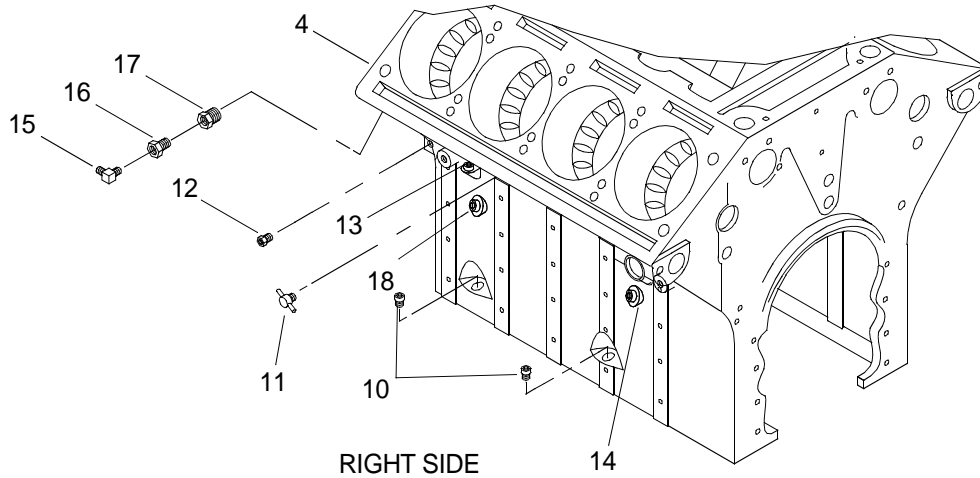

64. Remove drain cock (11).

65. Remove plug (12).

66. Remove oil galley plugs (13) and (14).

67. Remove elbow (15), fitting (16) and reducer bushing (17).

68. Remove plug (18).

69. Remove two plugs (19) from left side of engine block (4).

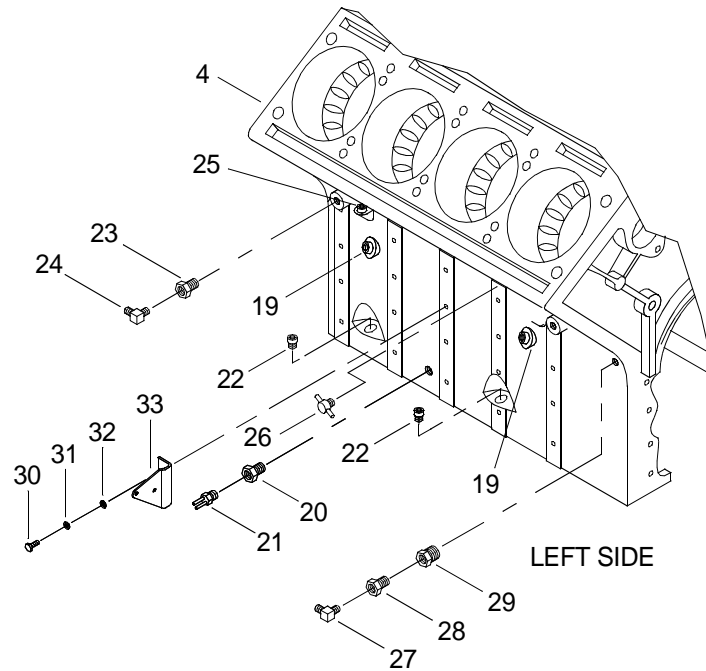

70. Remove reducing bushing (20) and ether starting aid thermostat (21).

71. Remove two plugs (22).

-
72. Remove reducing bushing (23) and elbow (24).
 73. Remove oil plug (25).
 74. Remove drain cock (26).
 75. Remove elbow (27), reducing bushing (28) and fitting (29).
 76. Remove two hex head screws (30), lock washers (31), flat washers (32) and starter motor bracket (33).
 77. Remove core plug (34) and gasket (35) from top of engine block (4) using core plug remover/installer. Discard gasket.

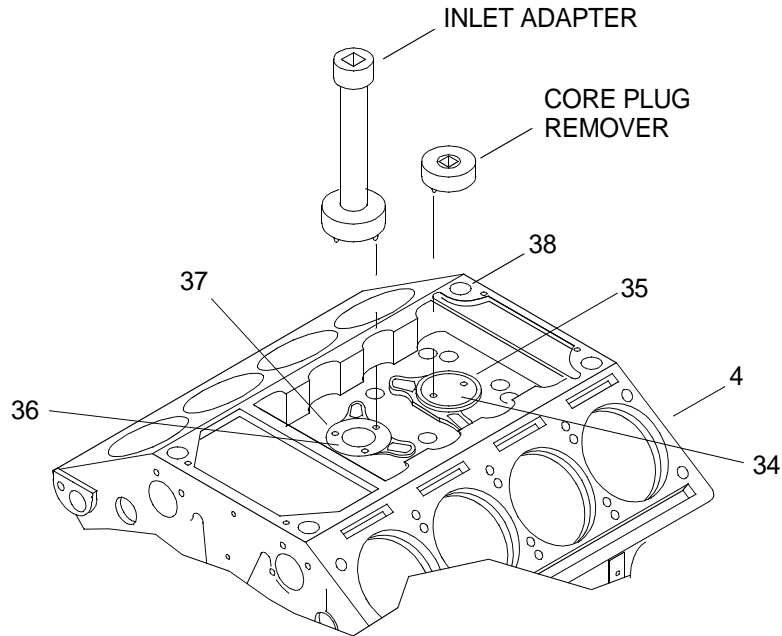

78. Remove aftercooler water inlet adaptor (36) and gasket (37) using aftercooler water inlet adaptor remover. Discard gasket.
79. Remove oil galley plugs (38).

80. Remove four hex head screws (39), washers (40), cover plate (41) and gasket (42) from left side of engine block (4). Discard gasket.

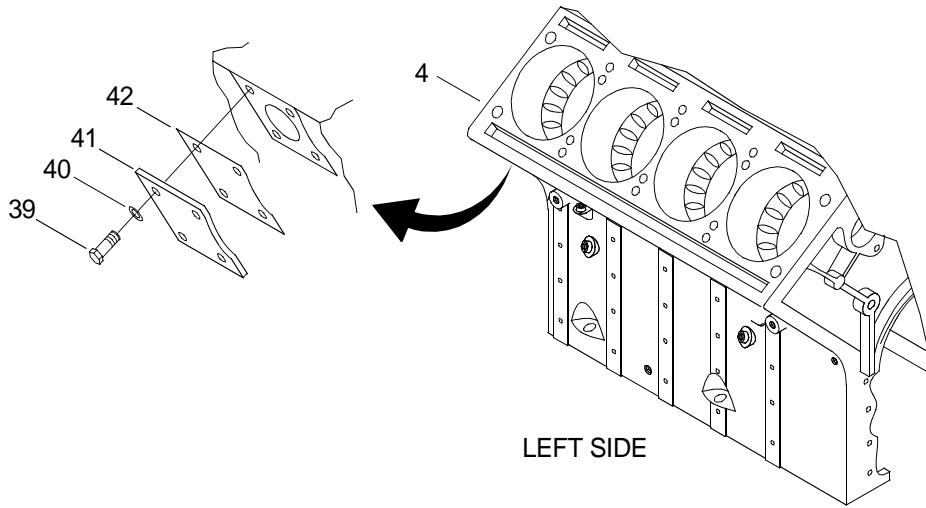

NOTE

The plugs and dowels in the following steps should be removed only if damaged.

81. Remove two dowels (43) from top of engine block (4).

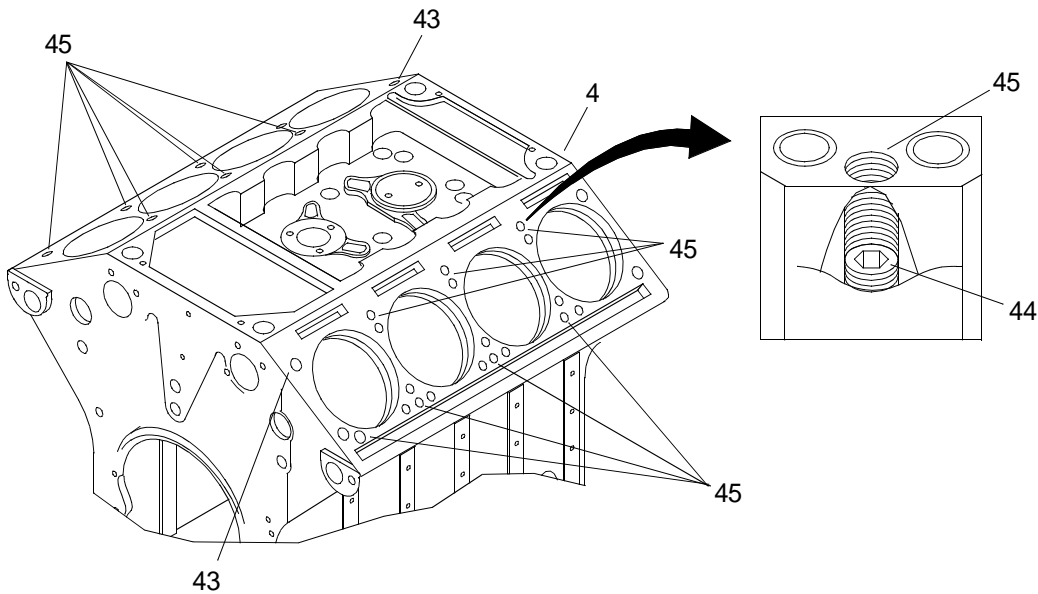

82. Remove fourteen plugs (44) from bottom of cylinder head screw holes (45).

83. Remove two dowels (46) from front of engine block (4).

84. Remove three plugs (47).

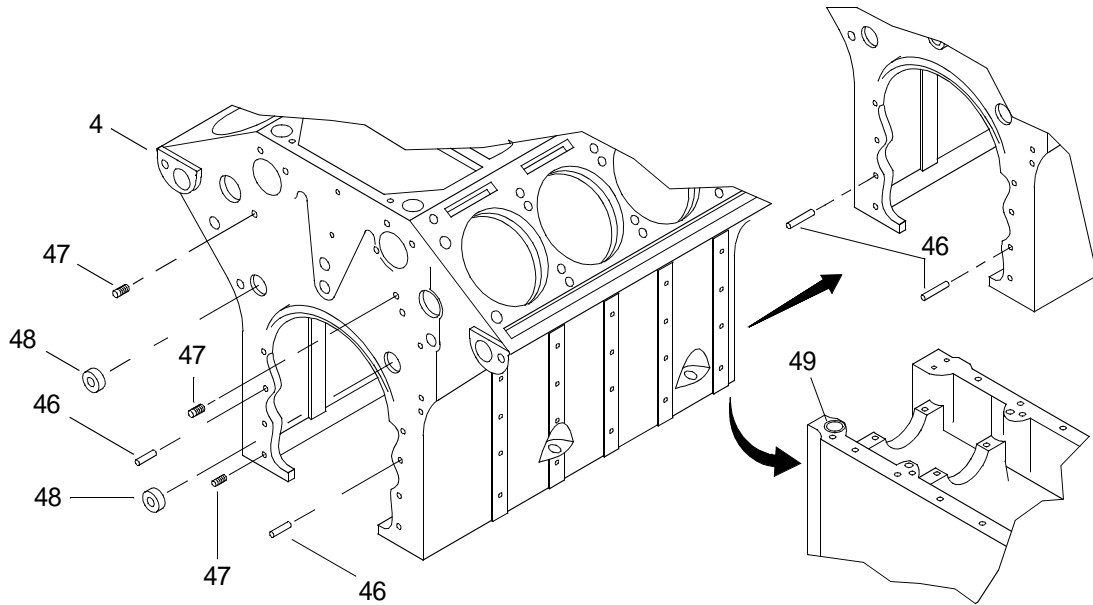

85. Remove and discard two plugs (48).

86. Remove two dowels (46) from rear of engine block (4).

87. Remove and discard cup plug (49) from bottom of engine block (4).

88. Remove four cup plugs (50) from right and left sides of engine block (4) and discard.

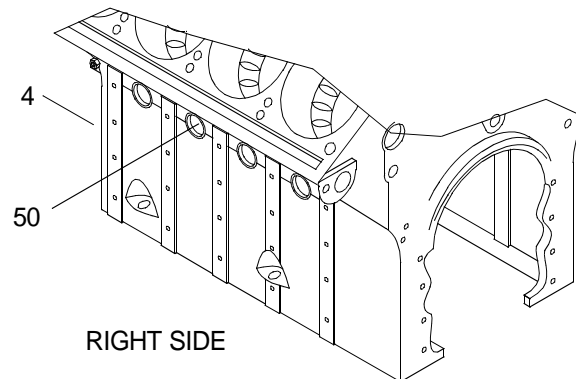

CLEAN ENGINE BLOCK

WARNING



EYE PROTECTION

1. Clean gasket material and sealant off engine block (4) surfaces using scraper.

WARNING

EYE PROTECTION



CHEMICAL



HOT AREA

- Clean engine block (4) using cleaning compound solution, making sure oil and water galleries are cleaned thoroughly.

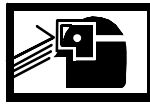
WARNING

EYE PROTECTION



CHEMICAL

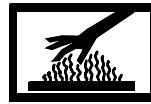

HOT AREA

- Rinse engine block (4) with clear water or steam clean.

WARNING

EAR PROTECTION



EYE PROTECTION

Do not exceed 30 PSI when using compressed air for cleaning. Failure to comply could result in injury to personnel.

- Dry engine block (4) thoroughly with compressed air.

INSPECT ENGINE BLOCK

- Inspect cylinder bore (51), grooves (52) and lands (53) for pitting and corrosion. None Allowed.

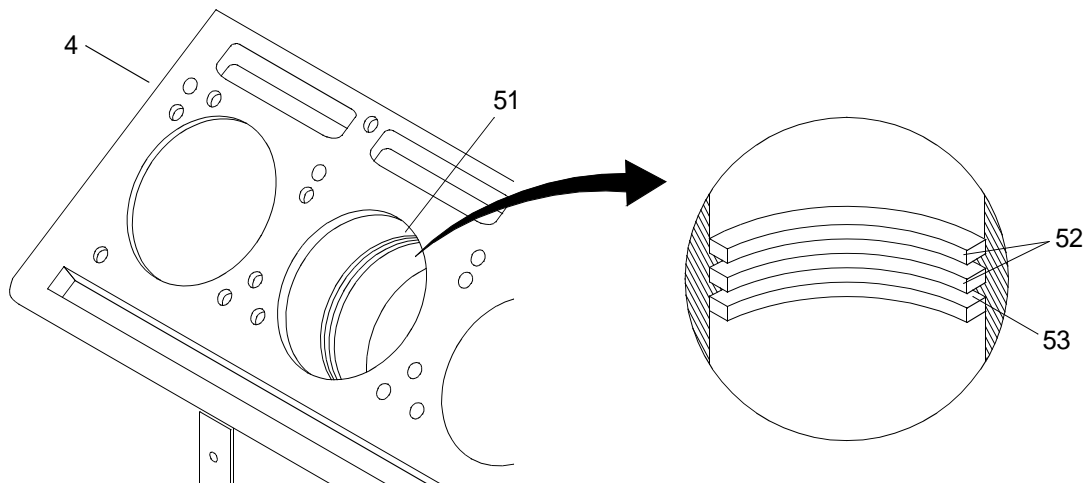

NOTE

All eight cylinders are measured in the same manner. Repeat the following step and substeps for each cylinders.

2. Measure cylinder bore (51) diameter on X and Y axis using a cylinder bore gauge.

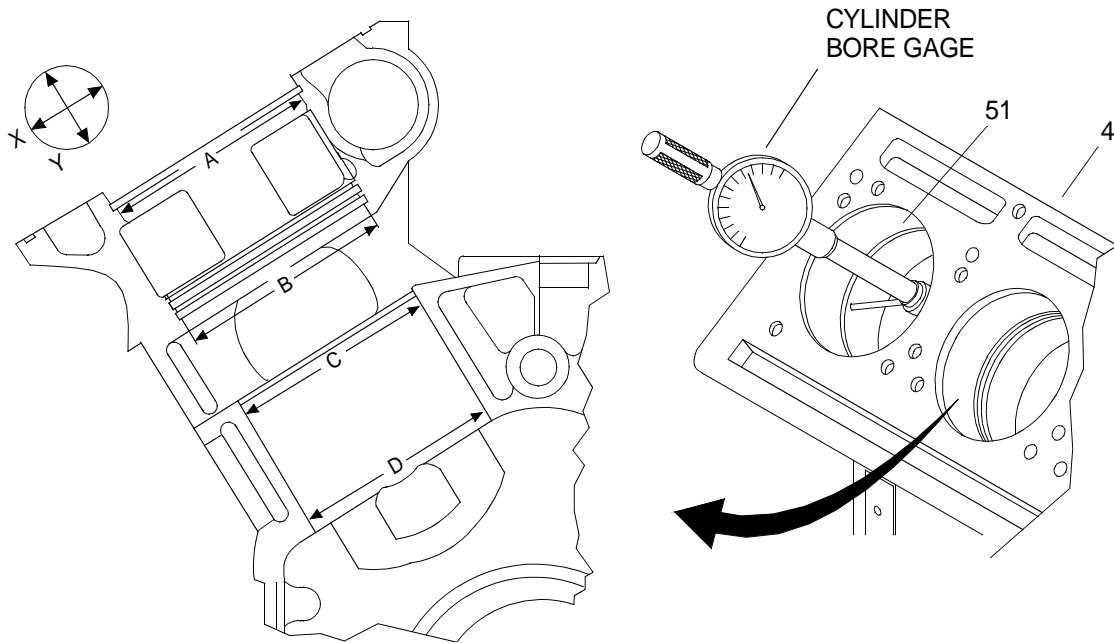

- a. Position A diameter shall not exceed 5.3625 in. (136.2075 mm).
- b. Position B diameter shall not exceed 5.3390 in. (135.6106 mm).

NOTE

The diameter at position C and D is the average of the four cylinder bore gauge readings.

- c. Position C measurement shall not exceed 5.2180 in. (132.5372 mm).
 - d. Position D measurement shall not exceed 5.2180 in. (132.5372 mm).
3. Should any cylinder bore (51) exceed limits, replace engine block (4).

4. Using a straight edge and feeler gauge, measure engine block (4) flatness crosswise between all cylinder bores (51).

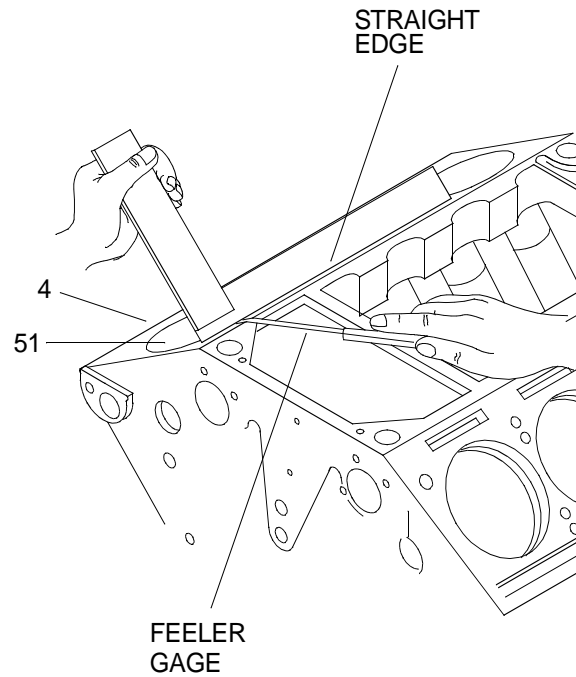

5. Should engine block flatness vary more than 0.003 in. (0.076 mm), replace engine block (4).
6. Using a straight edge and feeler gauge, measure engine block (4) flatness lengthwise between all cylinder bores (51).
7. Should engine block (4) flatness vary more than 0.007 in. (0.178 mm), replace engine block.

NOTE

Cylinders may be counterbored to either of two depths.

8. Using a counterbore depth gauge, measure cylinder bore (51) counterbore depth at point A.

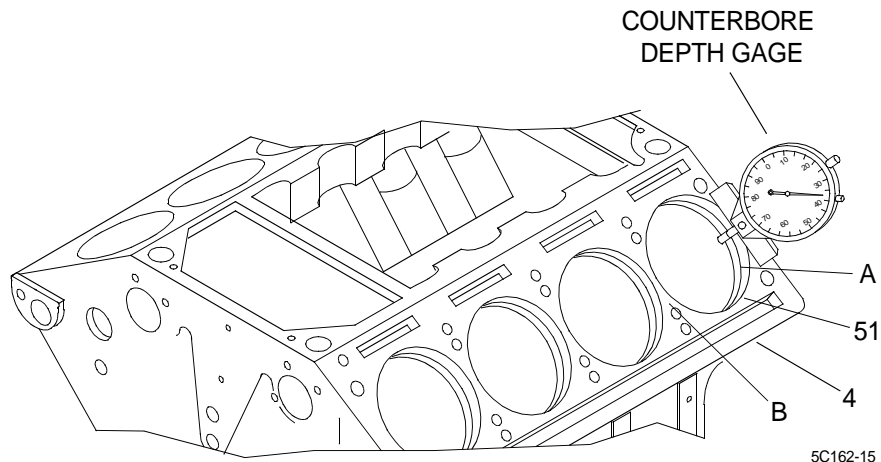

5C162-15

NOTE

Depths not meeting the following measurements may be corrected by changing the cylinder liner thickness.

9. Counterbore depth at point A shall be between 0.4755 and 0.477 in. (12.13 and 12.12 mm) or between 0.4905 and 0.4920 in. (12.46 and 12.50 mm). Should measurements be out of tolerance, replace engine block (4).
10. Should the counterbore at point A vary more than 0.0015 in. (0.04mm) around the edges of the cylinder, replace the engine block (4).
11. Should the difference between any two adjacent cylinder counterbores at point B be more than 0.0015 in. (0.04 mm), replace engine block (4).

NOTE

Main bearing caps must be installed in same position as marked during removal. Make sure the caps are firmly seated and the bearings are removed.

12. Install five main bearing caps (54) and ten hex head screws (55)

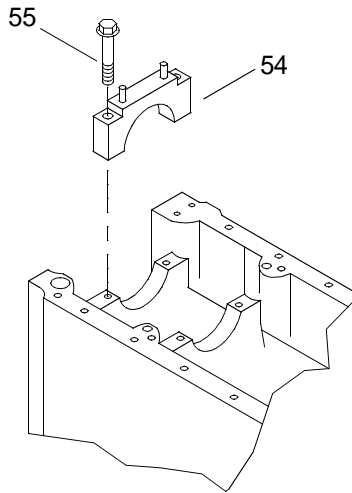

13. Tighten hex head screws (55).
14. Strike caps (54) with a dead blow hammer to seat them.
15. Torque hex head screws (55) to 50 ft lbs (68 N-m) using torque wrench.
16. Torque hex head screws (55) to 110 ft lbs (149 N-m) using torque wrench.
17. Torque hex head screws (55) to 250 ft lbs (339 N-m) using torque wrench.

18. Measure each main bearing bore (56) diameter using bore gauge.

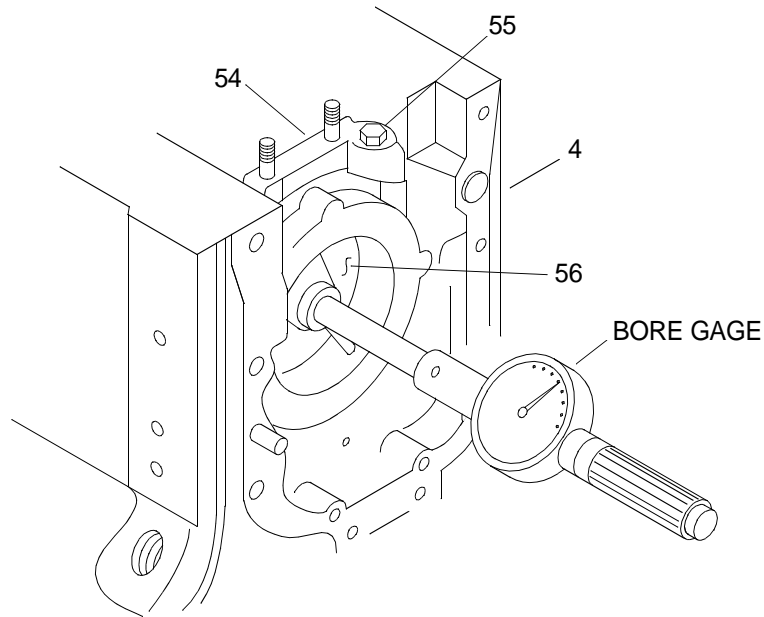

19. Diameter should be between 4.812 and 4.813 in. (122.22 and 122.25 mm). Should main bearing bore diameter be out of tolerance, replace engine block (4).
20. Remove hex head screws (55) and five main bearing caps (54).
21. Inspect dowel holes (43) to ensure they are not oversized or damaged. Should dowel holes be oversized or damaged, replace engine block (4).

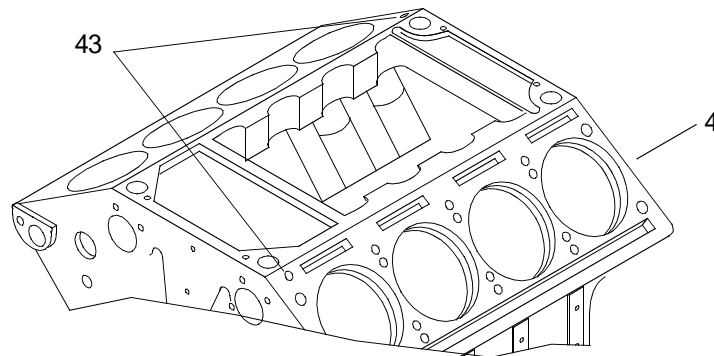

22. Inspect all threaded holes for stripped or crossed threads, use a tap to clean out threads. If threaded holes cannot be repaired, replace engine block (4).

TEST ENGINE BLOCK

WARNING**CHEMICAL****EYE PROTECTION**

1. Coat core plug (34) threads with sealing compound.

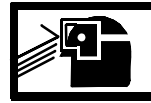
WARNING**CHEMICAL****EYE PROTECTION**

2. Install core plug (34) and new gasket (35) in top of engine block (4) using core plug remover/installer.

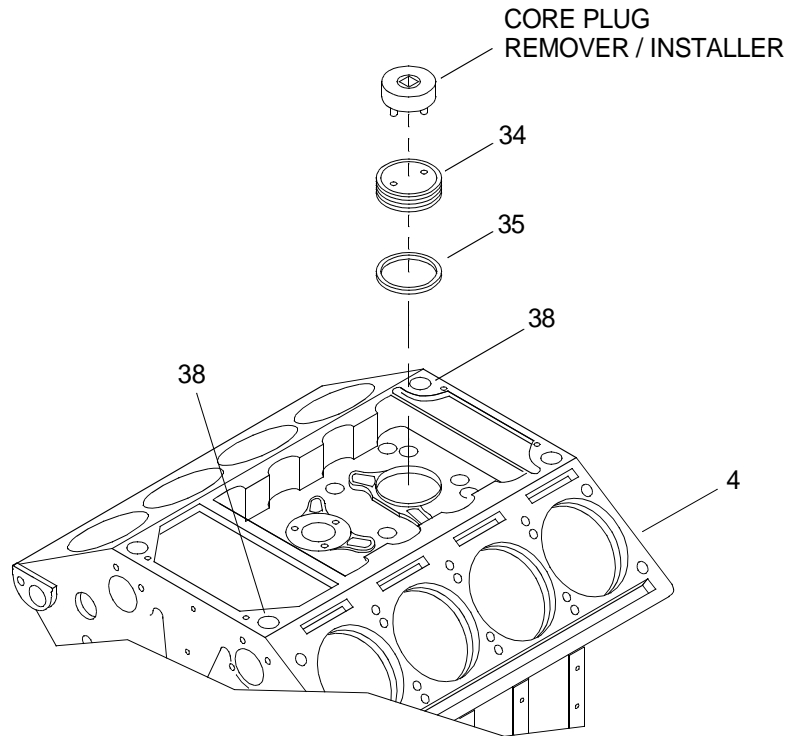

3. Torque plug (34) to 230-270 ft lbs (311-366 N-m) using torque wrench and core plug remover/installer.

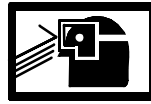
WARNING**CHEMICAL****EYE PROTECTION**

4. Coat oil galley plugs (38) threads with sealing compound.

WARNING**CHEMICAL****EYE PROTECTION**

5. Install oil galley plugs (38).
6. Torque plug (38) to 168-192 in. lbs (19-22 N-m) using torque wrench and socket set.
7. Install two dowels (43) in top of engine block (4) until they are flush.

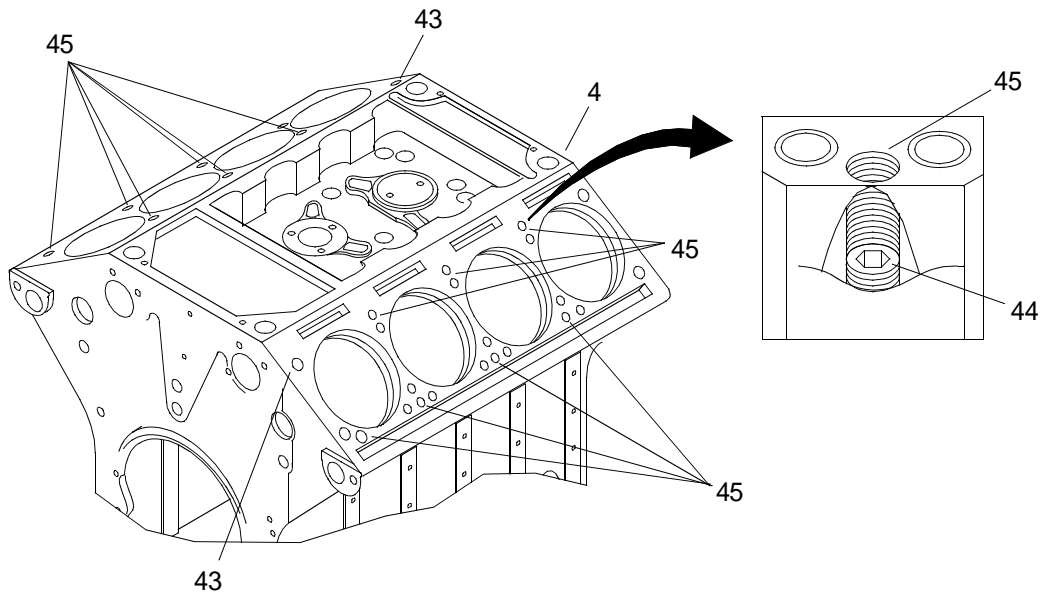
**WARNING****CHEMICAL****EYE PROTECTION**

8. Coat fourteen plugs (44) threads with sealing compound.

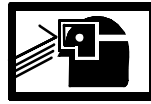
WARNING**CHEMICAL****EYE PROTECTION**

9. Install fourteen plugs (44) in cylinder head screw holes (45).
10. Torque plugs (44) to 50-60 ft lbs (68-81 N-m) using torque wrench.
11. Install two dowels (46) on front of engine block (4) leaving 3/8 in. extended.

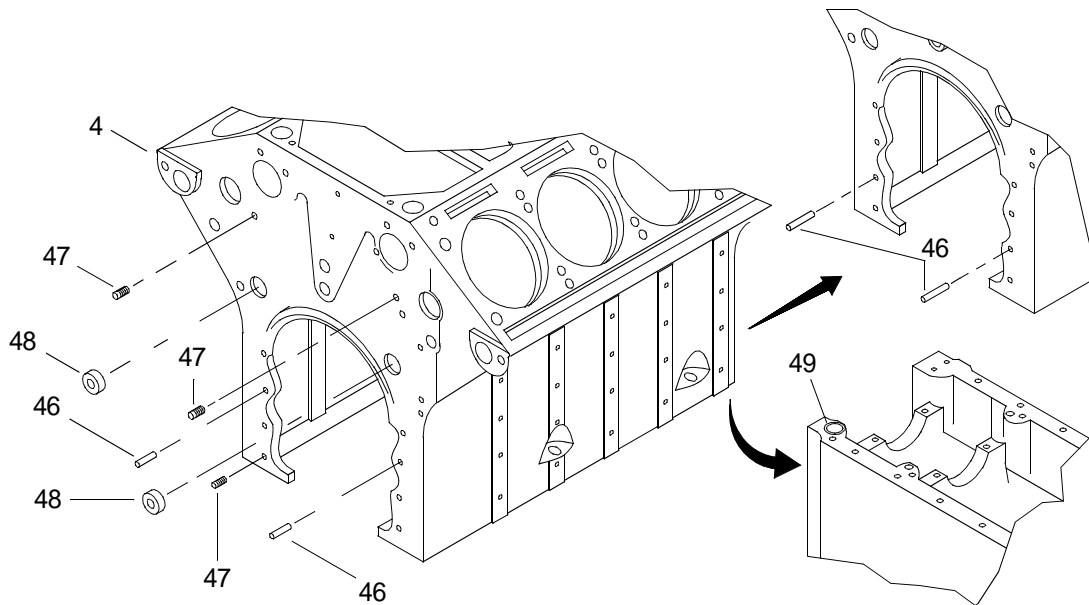
**WARNING****CHEMICAL****EYE PROTECTION**

12. Coat three plugs (47) and two plugs (48) threads with pipe thread sealing compound.

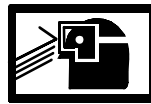
WARNING**CHEMICAL****EYE PROTECTION**

13. Install three plugs (47) and two plugs (48).
14. Install two dowels (46) on rear of engine block (4) leaving 3/8 in. extended.

WARNING

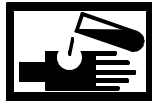

CHEMICAL

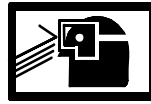

EYE PROTECTION

15. Coat new cup plug (49) threads with sealing compound.

WARNING



CHEMICAL

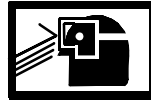

EYE PROTECTION

16. Install new cup plug (49) on bottom of engine block (4).

WARNING



CHEMICAL

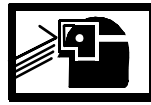

EYE PROTECTION

17. Coat four new cup plug (50) threads with sealing compound.

WARNING



CHEMICAL

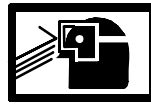

EYE PROTECTION

18. Install four new cup plugs (50) on both the right and left sides of engine block (4).

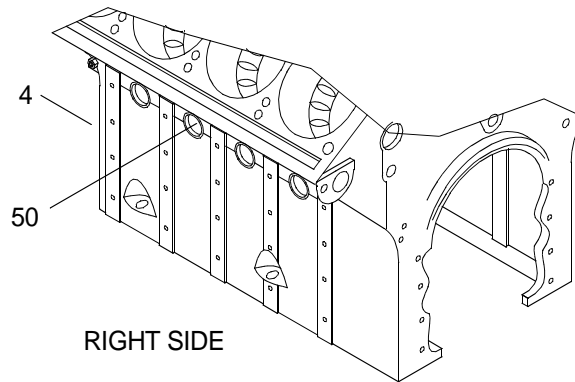

WARNING

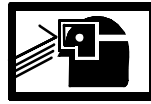
**CHEMICAL****EYE PROTECTION**

19. Coat oil galley plugs (1) threads with sealing compound.

WARNING

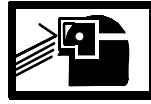
**CHEMICAL****EYE PROTECTION**

20. Install oil galley plugs (1) in front engine block (4).

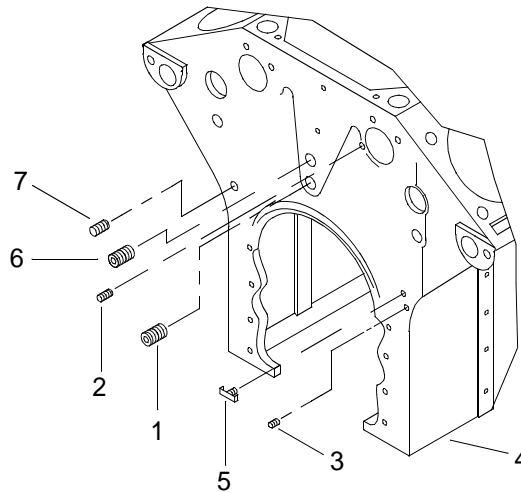

21. Torque plug (1) to 396-444 in. lbs (45-50 N-m) using torque wrench and socket set.

WARNING

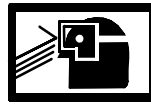
**CHEMICAL****EYE PROTECTION**

22. Coat oil galley plug (2) threads with sealing compound.

WARNING

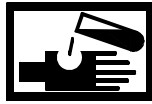
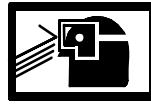
**CHEMICAL****EYE PROTECTION**

23. Install oil galley plug (2).
24. Torque plug (2) to 23-27 ft lbs (31-37 N-m) using torque wrench and wrench set.

WARNING

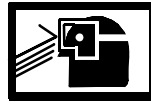
**CHEMICAL****EYE PROTECTION**

25. Coat oil galley plug (3) threads with sealing compound.

WARNING

**CHEMICAL****EYE PROTECTION**

26. Install oil galley plug (3).
27. Torque plug (3) to 228-264 in. lbs (26-30 N-m) using torque wrench and socket set.

WARNING

**CHEMICAL****EYE PROTECTION**

28. Coat drain cock (5) threads with sealing compound.

WARNING

**CHEMICAL****EYE PROTECTION**

29. Install drain cock (5).

WARNING

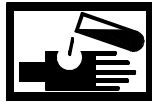

CHEMICAL

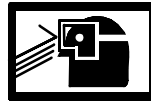

EYE PROTECTION

30. Coat plug (6) threads with sealing compound.

WARNING



CHEMICAL

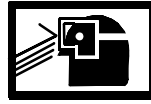

EYE PROTECTION

31. Install plug (6).
32. Torque plug (6) to 95-105 ft lbs (129-142 N-m) using torque wrench.

WARNING

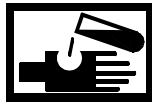

CHEMICAL

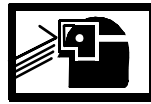

EYE PROTECTION

33. Coat plug (7) threads with sealing compound.

WARNING



CHEMICAL

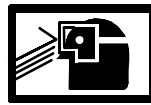

EYE PROTECTION

34. Install plug (7).
35. Torque plug (7) to 228-264 in. lbs (26-30 N-m) using torque wrench and socket set.

WARNING



CHEMICAL



EYE PROTECTION

36. Coat oil galley plug (8) threads with sealing compound.

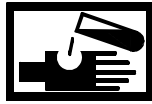
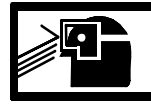
WARNING**CHEMICAL****EYE PROTECTION**

37. Install oil galley plug (8) in rear of engine block (4).

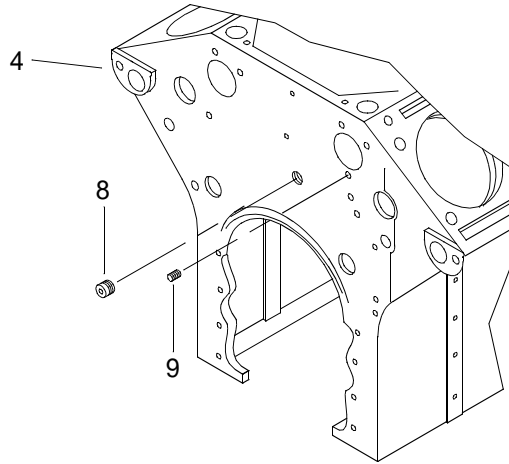

38. Torque plug (8) to 276-324 in. lbs (31-37 N-m) using torque wrench and socket set.

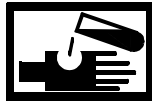
WARNING**CHEMICAL****EYE PROTECTION**

39. Coat oil galley plug (9) threads with sealing compound.

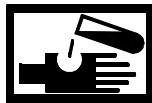
WARNING**CHEMICAL****EYE PROTECTION**

40. Install oil galley plug (9) in rear engine block (4).
41. Torque plug (9) to 396-444 in. lbs (45-50 N-m) using torque wrench and socket set.

WARNING

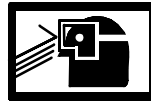
**CHEMICAL****EYE PROTECTION**

42. Coat plug (10) threads with sealing compound.

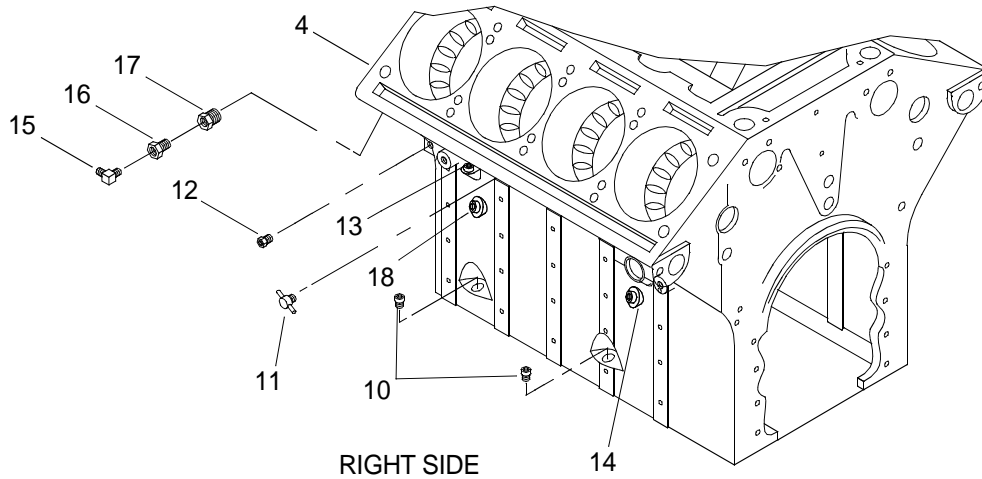

WARNING

**CHEMICAL****EYE PROTECTION**

43. Install two plugs (10) in right side of engine block (4).
44. Torque plugs (10) to 168-192 in. lbs (19-22 N-m) using torque wrench and socket set.

WARNING

**CHEMICAL****EYE PROTECTION**

45. Coat drain cock (11) threads with sealing compound.

WARNING

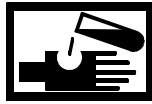

CHEMICAL

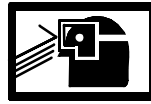

EYE PROTECTION

46. Install drain cock (11).

WARNING



CHEMICAL



EYE PROTECTION

47. Coat plug (12) threads with sealing compound.

WARNING



CHEMICAL



EYE PROTECTION

48. Install plug (12).

49. Torque plug (12) to 396-444 in. lbs (45-50 N-m) using torque wrench and socket set.

WARNING

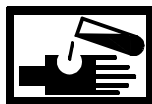

CHEMICAL



EYE PROTECTION

50. Coat oil galley plug (13) threads with sealing compound.

WARNING



CHEMICAL



EYE PROTECTION

51. Install oil galley plug (13).

52. Torque plug (13) to 120-144 in. lbs (14-16 N-m) using torque wrench and socket set.

WARNING

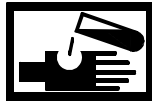

CHEMICAL

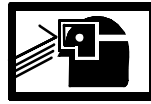

EYE PROTECTION

53. Coat oil galley plug (14) threads with sealing compound.

WARNING



CHEMICAL

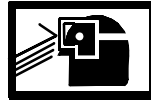

EYE PROTECTION

54. Install oil galley plug (14).
55. Torque plug (14) to 396-444 in. lbs (45-50 N-m) using torque wrench and socket set.

WARNING



CHEMICAL

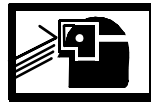

EYE PROTECTION

56. Coat reducer bushing (17) threads with sealing compound

WARNING



CHEMICAL



EYE PROTECTION

57. Install reducer bushing (17).

WARNING



CHEMICAL



EYE PROTECTION

58. Coat fitting (16) threads with sealing compound.

WARNING

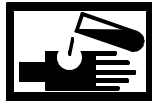

CHEMICAL

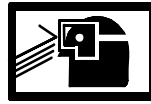

EYE PROTECTION

59. Install fitting (16).

WARNING



CHEMICAL

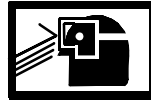

EYE PROTECTION

60. Coat elbow (15) threads with sealing compound

WARNING



CHEMICAL



EYE PROTECTION

61. Install elbow (15).

WARNING



CHEMICAL

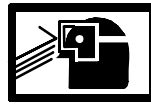

EYE PROTECTION

62. Coat plug (18) threads with sealing compound.

WARNING



CHEMICAL



EYE PROTECTION

63. Install plug (18).

64. Torque plug (18) to 75-85 ft lbs (102-115 N-m) using torque wrench and socket set.

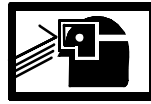
WARNING**CHEMICAL****EYE PROTECTION**

65. Coat threads of two plugs (19) with sealing compound.

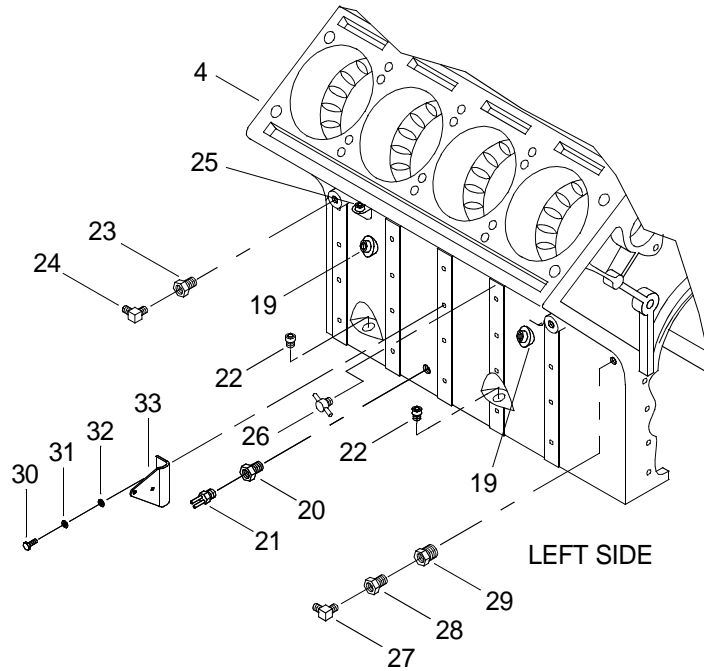
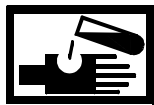
**WARNING****CHEMICAL****EYE PROTECTION**

66. Install two plugs (19) in left side of engine block (4).
67. Torque plugs (19) to 75-85 ft lbs (102-115 N-m) using torque wrench and socket set.

WARNING**CHEMICAL****EYE PROTECTION**

68. Coat reducing bushing (20) threads with sealing compound.

WARNING

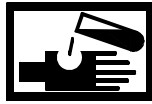
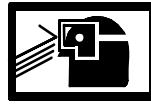
**CHEMICAL****EYE PROTECTION**

69. Install reducing bushing (20) and ether starting aid thermostat (21).

WARNING

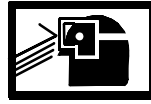
**CHEMICAL****EYE PROTECTION**

70. Coat two plugs (22) threads with sealing compound.

WARNING

**CHEMICAL****EYE PROTECTION**

71. Install two plugs (22).
72. Torque plugs (22) to 228-264 in. lbs (26-30 N-m) using torque wrench and socket set.

WARNING

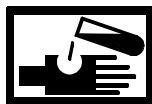
**CHEMICAL****EYE PROTECTION**

73. Coat reducing bushing (23) threads with sealing compound.

WARNING

**CHEMICAL****EYE PROTECTION**

74. Install reducing bushing (23) in engine block (4).

WARNING

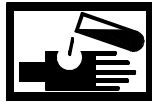
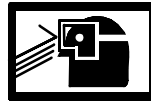
**CHEMICAL****EYE PROTECTION**

75. Coat elbow (24) threads with sealing compound.

WARNING

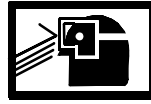
**CHEMICAL****EYE PROTECTION**

76. Install elbow (24) in engine block (4).

WARNING

**CHEMICAL****EYE PROTECTION**

77. Coat oil plug (25) threads with sealing compound.

WARNING

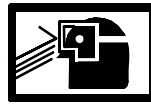
**CHEMICAL****EYE PROTECTION**

78. Install oil plug (25).

79. Torque plug (25) to 120-144 in. lbs (14-16 N-m) using torque wrench and socket set.

WARNING

**CHEMICAL****EYE PROTECTION**

80. Coat drain cock (26) threads with sealing compound.

WARNING

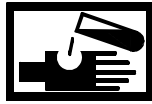

CHEMICAL

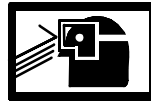

EYE PROTECTION

81. Install drain cock (26).

WARNING

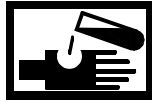

CHEMICAL

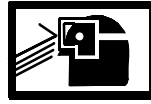

EYE PROTECTION

82. Coat fitting (29) threads with sealing compound.

WARNING



CHEMICAL



EYE PROTECTION

83. Install fitting (29).

WARNING



CHEMICAL

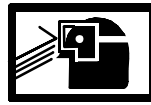

EYE PROTECTION

84. Coat reducing bushing (28) threads with sealing compound.

WARNING



CHEMICAL



EYE PROTECTION

85. Install reducing bushing (28).

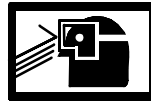
WARNING**CHEMICAL****EYE PROTECTION**

86. Coat elbow (27) threads with sealing compound.

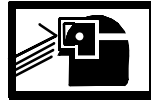
WARNING**CHEMICAL****EYE PROTECTION**

87. Install elbow (27).
88. Install starter motor bracket (33) using two hex head screws (30), with lock washers (31) and flat washers (32).
89. Install cover plate (41) with new gasket (42) using four hex head screws (39) with washers (40), on left side of engine block (4).

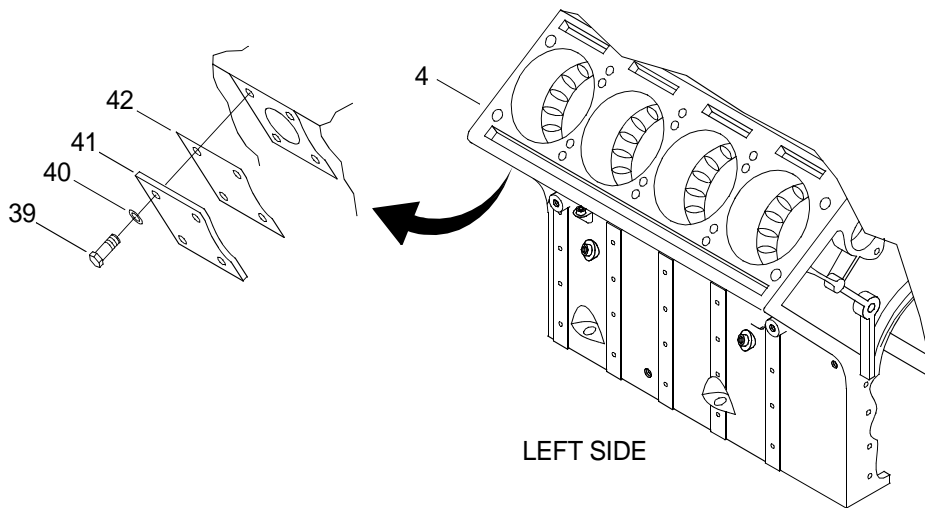
**WARNING****CHEMICAL****EYE PROTECTION****NOTE**

The following steps are for testing only. New components will be installed during assembly.

90. Coat two seal rings (57) with lubricating oil.

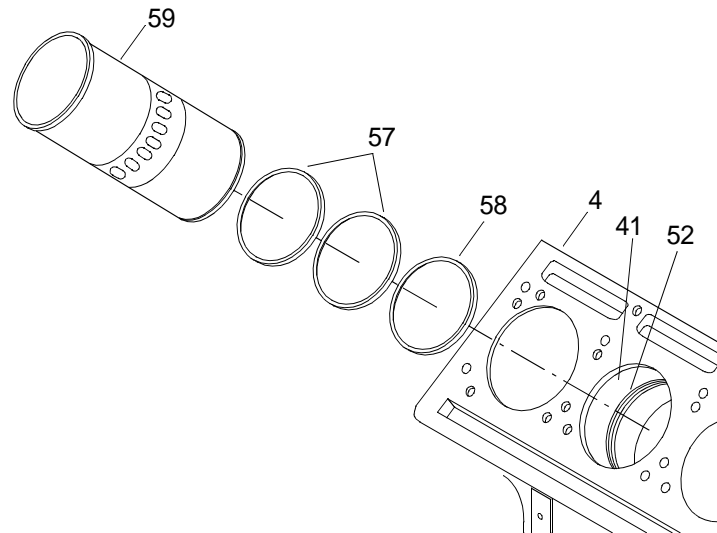

WARNING



CHEMICAL

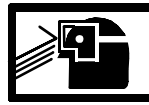

EYE PROTECTION

91. Install two seal rings (57) in grooves (52) of each cylinder (51) in engine block (4).
92. Install cylinder liner inserts (58) into each cylinder (51) recess.
93. Install eight cylinder liners (59).
94. Install eight compression gaskets (60).

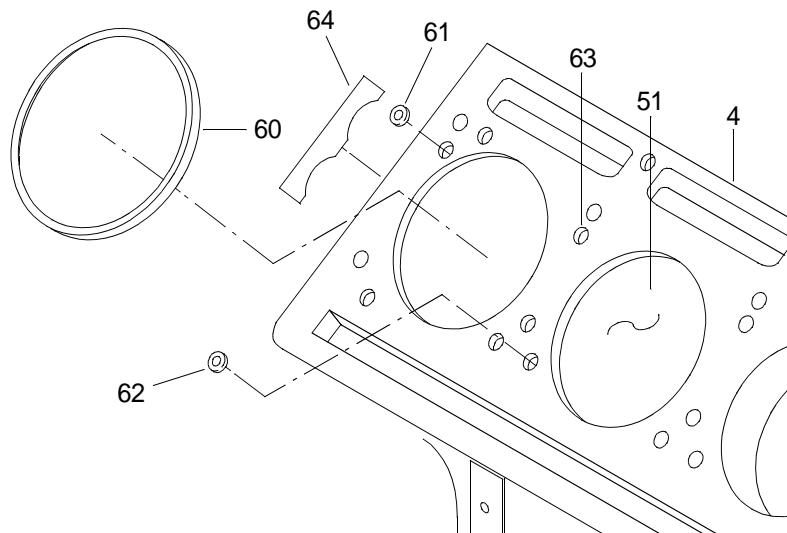

95. Install oil hole seals (61) and water hole seals (62) in 34 counterbored holes (63) on each side of engine block (4).
96. Install four shims (64), one at each end of cylinder head contact surface of each side of engine block (4).

97. Install water inlet cover plate with new gasket (65) with four hex head screws (66), with lock washers (67).

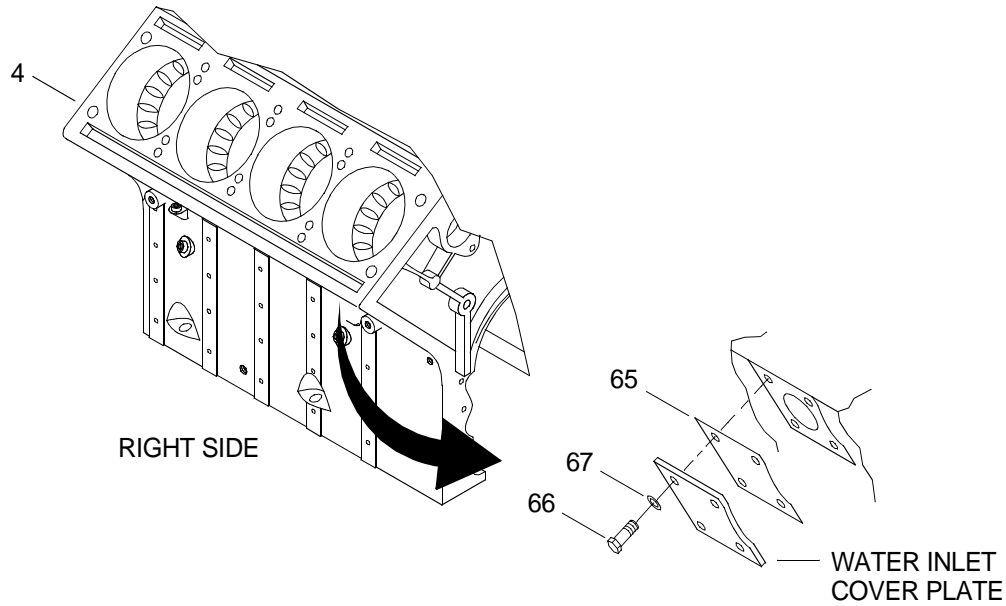

98. Install engine block pressure test core plug and gasket in the hole for the aftercooler water inlet adaptor (36) using core plug remover/installer.

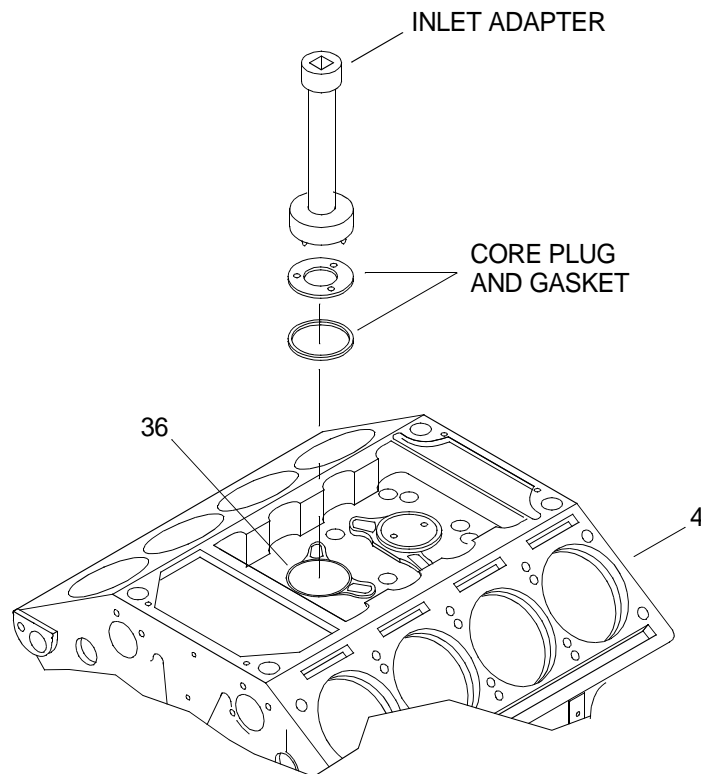

99. Torque engine block pressure test core plug to 230 – 270 ft lbs (311– 366 N-m) using torque wrench and socket set.

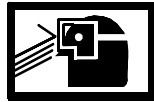
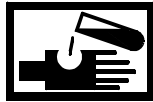
WARNING**EYE PROTECTION****CHEMICAL****POISON****VAPOR**

100. Pour one gallon of antifreeze into engine block water jacket fitting (68).

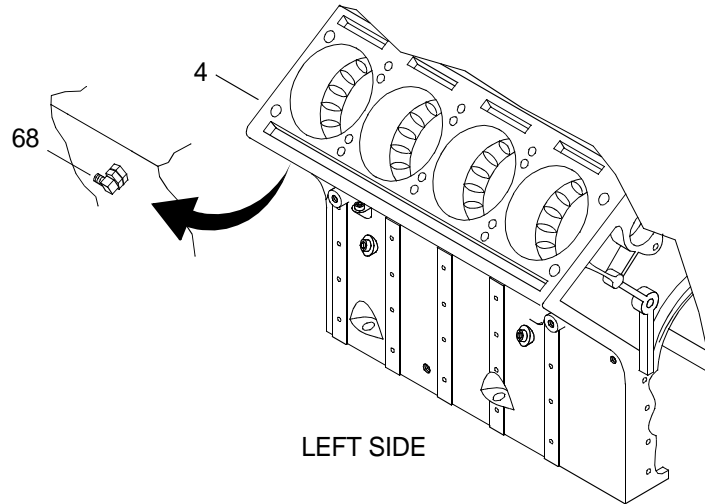

101. Add water until engine block water jacket is full.

102. Connect an air line to fitting (68) and route air line above engine block (4) to prevent antifreeze from entering air line.

103. Install two cylinder block pressure testing kit plates using 20 hex head screws with spacers on the right and left banks of engine block (4).

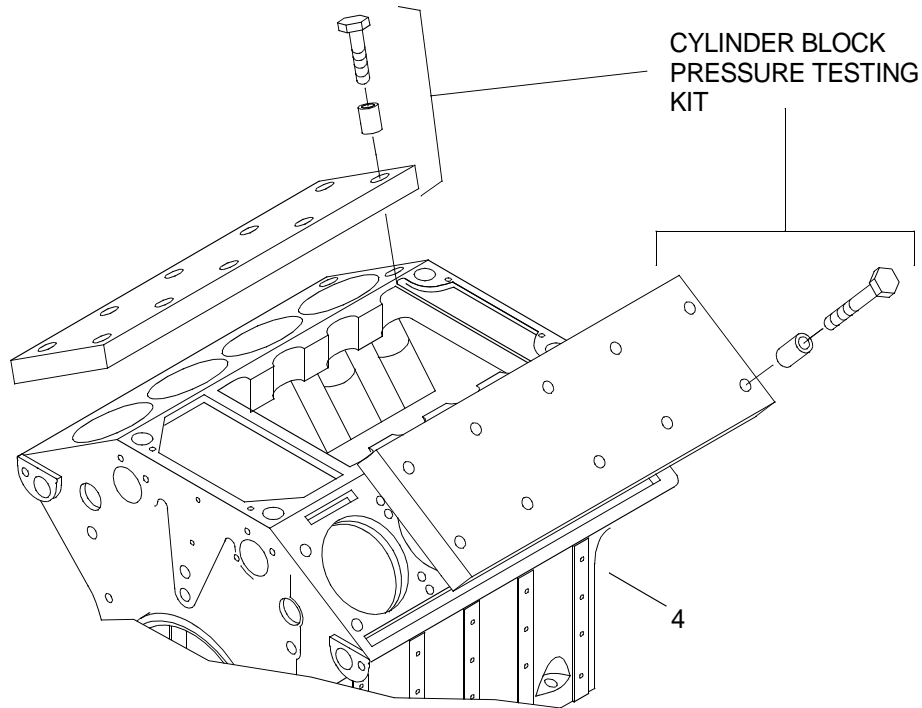

104. Torque cylinder block pressure testing kit hex head screws to 50 ft lbs (68 N-m) then to 110 ft lbs (149 N-m) using torque wrench.

WARNING

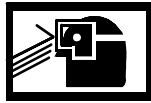

EYE PROTECTION

105. Apply 40 PSI of pressure to engine block (4) and maintain for at least two hours.
106. After two hours, inspect engine block (4) for leaking antifreeze. Should leaks be found in engine and cannot be repaired by replacing a gasket, seal or o-ring, replace engine block (4).

WARNING



EYE PROTECTION

107. Carefully release pressure from engine block (4).
108. Disconnect air line from fitting (68).

109. Remove cylinder block pressure testing kit, 20 hex head screws with spacers and two plates from engine block (4).
110. Remove engine block pressure test core plug and gasket from aftercooler water inlet adaptor (36) hole using core plug remover/installer.
111. Install aftercooler water inlet adaptor (36) and new gasket (37) using water inlet adaptor remover/installer.

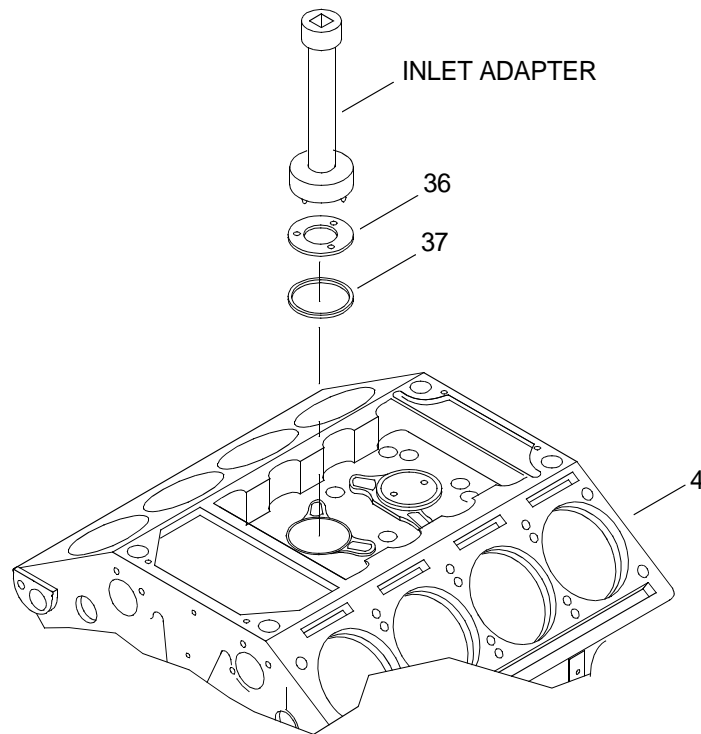

112. Torque water inlet adaptor (36) to 230-250 ft lbs (311-339 N-m) using torque wrench and inlet adaptor installer, remover.

113. Remove four hex head screws (66), with lock washers (67), and water inlet cover plate with gasket (65) from right side of engine block (4).

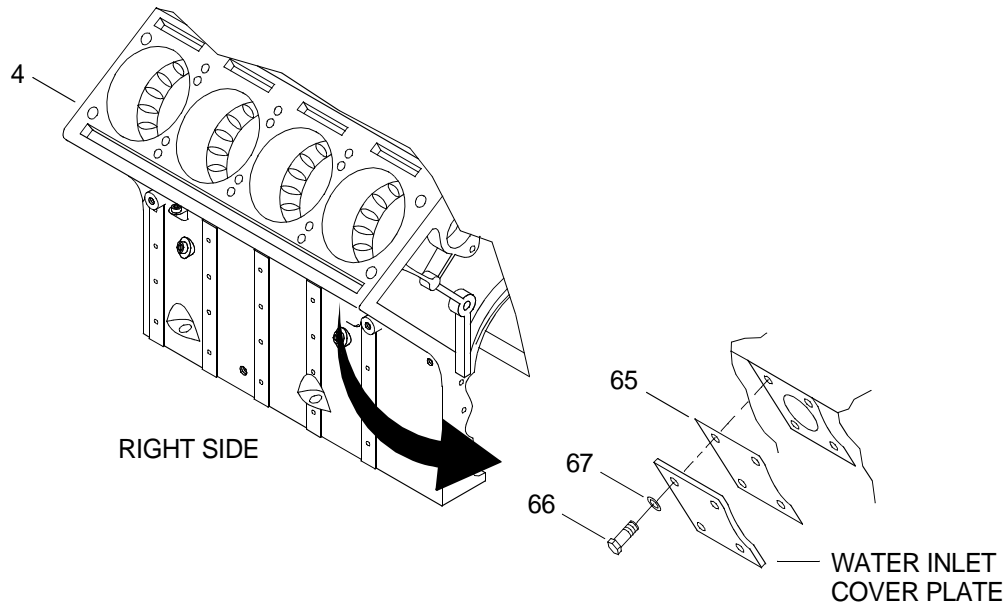

114. Remove eight compression gaskets (60) from cylinders (51).

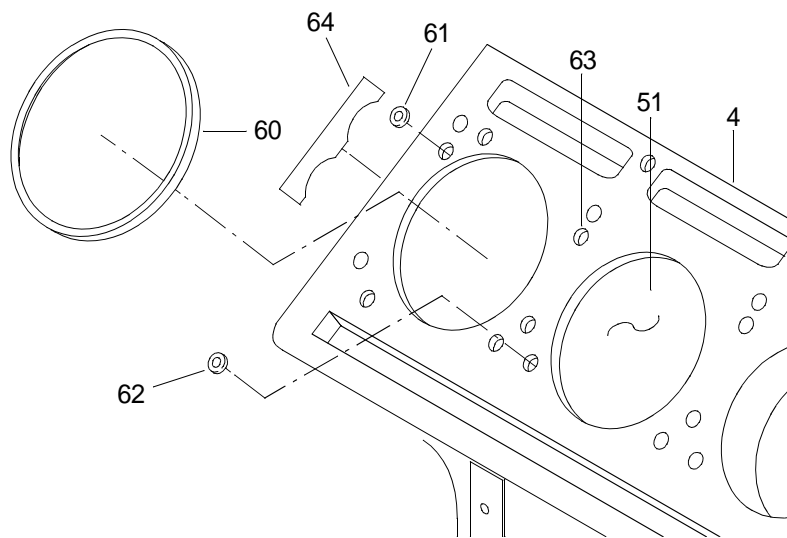

115. Remove oil hole seals (61) and water hole seals (62) from 34 counterbored holes (63) on both sides of the engine block (4).

116. Remove four shims (64) from each end of cylinder head surface.

117. Remove eight cylinder liners (59) from engine block (4).

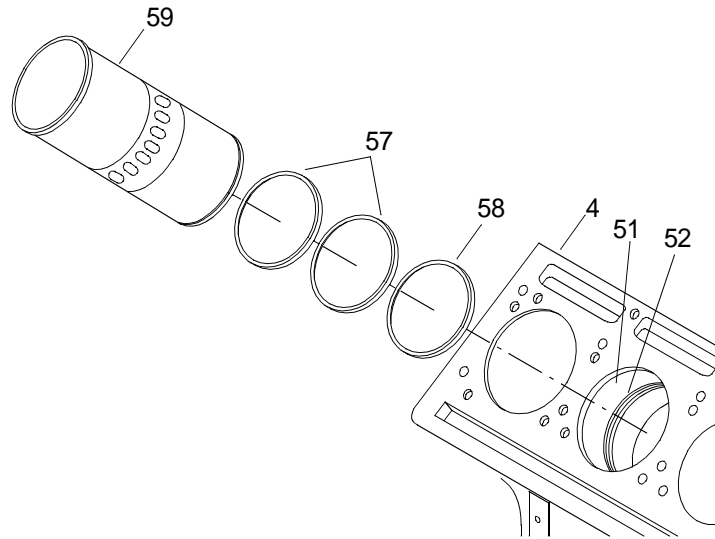

118. Remove cylinder liner inserts (58) from each cylinder (51) groove (52).

119. Remove two seal rings (57) from cylinder grooves (52).

WARNING



CHEMICAL

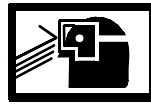

EYE PROTECTION

120. Coat engine block (4) with engine oil to prevent rust.

ASSEMBLE ENGINE BLOCK

1. Install crankshaft. (WP 0060 00)
2. Install vibration damper. (WP 0074 00)
3. Install pistons and cylinder liners. (WP 0072 00)
4. Install oil pump. (WP 0119 00)
5. Install oil pressure relief valve. (WP 0125 00)
6. Install oil pressure regulator valve. (WP 0123 00)
7. Install rear cylinder block plate. (WP 0038 00)
8. Install front cylinder block plate. (WP 0040 00)
9. Install camshaft balance weight. (WP 0065 00)
10. Install front balance cover. (WP 0076 00)

11. Install idler gear. (WP 0167 00)
12. Install camshafts and bearings. (WP 0062 00)
13. Install camshaft vibration damper. (WP 0063 00)
14. Install camshaft accessory drive pulley. (WP 0066 00)
15. Install water pump drive gear. (WP 0153 00)
16. Install water pump. (WP 0152 00)
17. Install fresh water cooling system filter head cover mounting bracket. (WP 0142 00)
18. Install fresh water cooling system filter head cover. (WP 0141 00)
19. Install fresh water cooling system filter element. (WP 0140 00)
20. Install cylinder heads. (WP 0046 00)
21. Install fuel injector. (WP 0091 00)
22. Install fuel system injector control. (WP 0086 00)
23. Install starboard fresh water outlet manifold. (WP 0151 00)
24. Install port fresh water outlet manifold. (WP 0150 00)
25. Install starboard thermostat housing. (WP 0144 00)
26. Install port thermostat housing. (WP 0145 00)
27. Install flywheel housing. (WP 0071 00)
28. Install raw water pump. (WP 0160 00)
29. Install electrical system hour meter bracket. (WP 0168 00)
30. Install electrical system hour meter. (WP 0167 00)
31. Install flywheel. (WP 0069 00)
32. Install oil pan (WP 0127 00)
33. Install after cooler. (WP 0155 00)
34. Install tachometer drive. (WP 0174 00)
35. Install heat exchanger. (WP 0138 00)
36. Install engine block breather pipe. (WP 0107 00)
37. Install electronic governor actuator. (WP 0098 00)
38. Install electronic governor rod assembly. (WP 0097 00)

-
39. Install blower drive. (WP 0112 00)
 40. Install blower drive shaft. (WP 0109 00)
 41. Install blower. (WP 0110 00)
 42. Install fuel pump. (WP 0094 00)
 43. Install fresh water cooling system by-pass hose. (WP 0148 00)
 44. Install cylinder head poppet valve rocker covers. (WP 0043 00)
 45. Remove engine from stand. (WP 0032 00)
 46. Install overspeed governor. (WP 0175 00)
 47. Install lube oil cooler. (WP 0128 00)
 48. Install lube oil dipstick tube assembly. (WP 0130 00)
 49. Install starting motor.(WP 0170 00)
 50. Install air box drains. (WP 0036 00)
 51. Install air box covers. (WP 0035 00)
 52. Install fuel cooler. (WP 0081 00)
 53. Install marine gear oil cooler. (TM 55-1945-205-24-1-3)
 54. Install exhaust manifolds. (WP 0163 00)
 55. Install turbochargers. (WP 0114 00)
 56. Install air intake housing. (WP 0103 00)
 57. Install air inlet collector assembly. (WP 0104 00)
 58. Install crankcase breather limiter assembly. (WP 0106 00)

END OF WORK PACKAGE

**UNIT LEVEL MAINTENANCE
CAUSEWAY FERRY
CYLINDER HEAD POPPET VALVE ROCKER ARM COVERS
REPLACEMENT**

INITIAL SETUP:**Tools**

Tool Kit, General Mechanic's (Rail and Marine) (Item 130, WP 0188 00)
Apron, Utility (Item 8, WP 0188 00)
Gloves, Chemical (Item 52, WP 0188 00)
Goggles, Industrial (Item 54, WP 0188 00)
Wrench, Torque (150-750 in. lbs) (Item 142, WP 0188 00)
Wrench Set, Socket (3/8 in. sqdr.) (Item 135, WP 0188 00)

Materials/Parts

Gasket, Cylinder Head Poppet Valve Rocker Arm Cover
(72582)
NSN 5330-01-078-7186
PN 5104081
Qty 2

Cover, Engine Cylinder Poppet Valve Rocker Arm
(72582)
NSN 2815-01-074-5270
PN 5103572

Cover, Engine Cylinder Poppet Valve Rocker Arm
(72582)
NSN 2815-01-074-0112
PN 5103574

Seal, Plain
(72582)
NSN 5330-01-088-2740
PN 5103646
Qty 2

Cleaner (Item 8, WP 0187 00)
Cloth, Cleaning (Item 13, WP 0187 00)

Personnel Required

Seaman 88K

References

TM 55-1945-205-10-1

Equipment Condition

Engine Cool To Touch.
SINCGARS Antenna Removed. (TM 11-5820-890-10-8)
Main Navigation Mast Removed. (TM 55-1945-205-24-1-1)
Intake Plenum Assembly Removed. (TM 55-1945-205-24-1-1)
Operators Cab Removed. (TM 55-1945-205-24-1-1)
Engine Hatch Removed. (TM 55-1945-205-24-1-1)
Crankcase Breather Limiter Assembly Removed. (WP 0106 00)
Air Inlet Collector Assembly Removed. (WP 0104 00)

REMOVE ENGINE CYLINDER HEAD POPPET VALVE ROCKER ARM COVERS

NOTE

This task is typical for the replacement of poppet valve rocker arm covers on both port and starboard engines.

1. Loosen hose clamp (1).

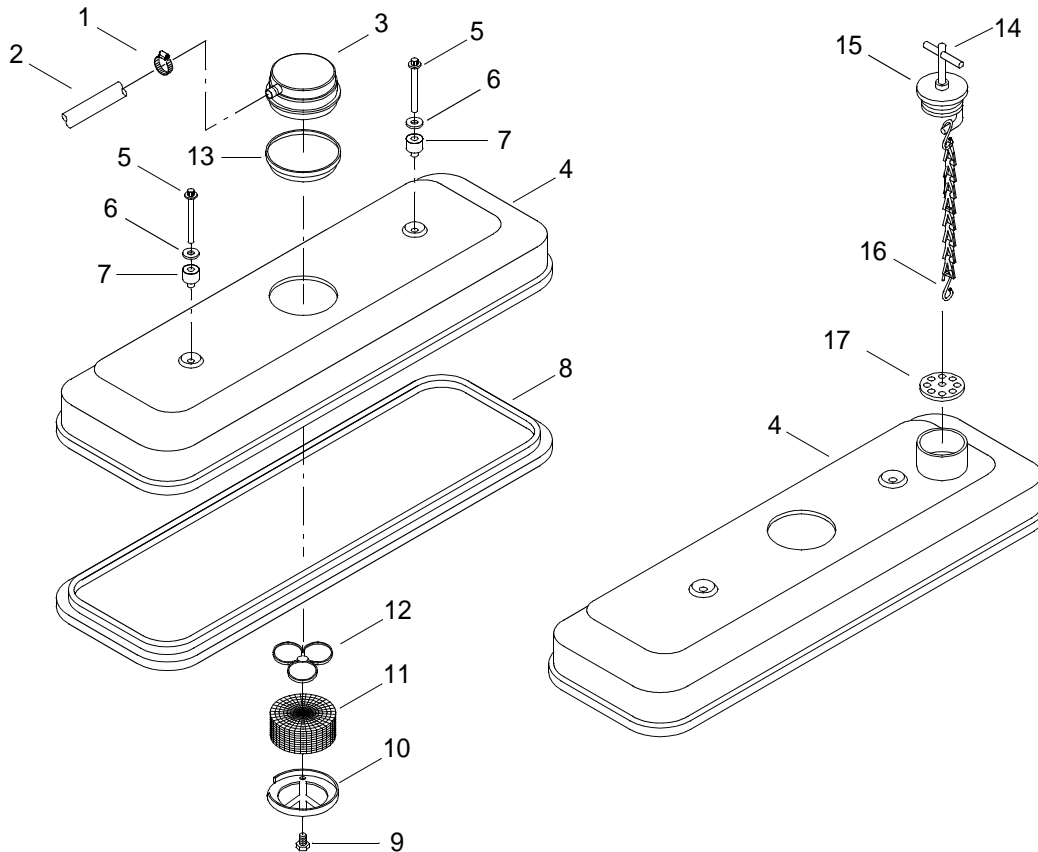

2. Disconnect hose (2) from breather housing (3).

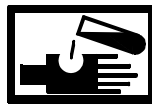
WARNING**CHEMICAL****EYE PROTECTION**

3. Using cleaning cloth and cleaner, clean cylinder head poppet valve rocker arm covers (4) and surrounding area.
4. Remove two bolts (5), lock washers (6) and silicone isolators (7) from cylinder head poppet valve rocker arm covers (4).
5. Remove cylinder head poppet valve rocker arm cover (4).
6. Remove cylinder head poppet valve rocker arm cover gasket (8) and discard.
7. Remove screw (9) from breather retaining plate (10).

8. Remove retaining plate (10), breather element (11) and retainer (12) from cylinder head poppet valve rocker arm cover (4).
9. Remove breather housing (3) and seal (13) from cylinder head poppet valve rocker arm cover (4). Discard seal (13).
10. Rotate filler cap plug handle (14) counterclockwise and remove filler cap plug (15) from cylinder head poppet valve rocker arm cover (4) (left cylinder head poppet valve rocker arm cover only).
11. Remove chain hook (16) from strainer (17).
12. Remove strainer (17) from cylinder head poppet valve rocker arm cover (1).

INSTALL ENGINE CYLINDER HEAD POPPET VALVE ROCKER ARM COVER

1. Install strainer (17) in new cylinder head poppet valve rocker arm cover (1) (left rocker cover only).
2. Install chain hook (16) on strainer (17).
3. Install filler cap plug (15) in cylinder head poppet valve rocker arm cover (4).
4. Rotate filler cap plug handle (14) clockwise and tighten.
5. Install new seal (13) and breather housing (3) on cylinder head poppet valve rocker arm cover (4).
6. Position retainer (12), breather element (11) and retaining plate (10) on cylinder head poppet valve rocker arm cover (4).
7. Install screw (9) in retaining plate (10) and tighten.
8. Install new gasket (8) on cylinder head poppet valve rocker arm cover (4).
9. Install cylinder head poppet valve rocker arm cover (4), two silicon isolators (7), lock washers (6) and bolts (5).
10. Using torque wrench and socket set, torque bolts (5) to 276 - 312 in. lbs (31.19 - 35.26 N-m).
11. Connect hose (2) to breather housing (3).
12. Tighten hose clamp (1).
13. Install engine air inlet collector assembly. (WP 0104 00)
14. Install crankcase breather limiter assembly. (WP 0106 00)
15. Install engine hatch. (TM 55-1945-205-24-1-1)
16. Install operators cab. (TM 55-1945-205-24-1-1)
17. Install intake plenum assembly. (TM 55-1945-205-24-1-1)
18. Install main navigation mast. (TM 55-1945-205-24-1-1)
19. Install SINGARS antenna. (TM 11-5820-890-10-8)
20. Perform operational check of diesel engine. (TM 55-1945-205-10-1)

END OF WORK PACKAGE

**UNIT LEVEL MAINTENANCE
CAUSEWAY FERRY
CYLINDER HEAD CRANKCASE BREATHER
CLEANING**

INITIAL SETUP:**Tools**

Tool Kit, General Mechanic's (Rail and Marine) (Item 131, WP 0188 00)
 Apron, Utility (Item 8, WP 0188 00)
 Gloves, Chemical (Item 52, WP 0188 00)
 Goggles, Industrial (Item 54, WP 0188 00)
 Brush, Stencil (Item 20 WP 0188 00)

Materials/Parts

Seal, Plain
 (72582)
 NSN 5330-01-088-2740
 PN 5103646
 Cloth, Cleaning (Item 13, WP 0187 00)
 Oil, Lubricating, Engine, 30W (Item 26, WP 0187 00)

Personnel Required

Engineer 88L

Equipment Condition

SINGGARS Antenna Removed. (TM 11-5820-890-10-8)
 Main Navigation Mast Removed. (TM 55-1945-205-24-1-1)
 Intake Plenum Assembly Removed. (TM 55-1945-205-24-1-1)
 Operators Cab Removed. (TM 55-1945-205-24-1-1)
 Engine Hatch Removed. (TM 55-1945-205-24-1-1)
 Engine Cool To Touch.
 Crankcase Breather Limiter Assembly Removed. (WP 0106 00)
 Air Inlet Collector Assembly Removed. (WP 0104 00)
 Cylinder Head Poppet Valve Rocker Arm Cover Removed. (WP 0043 00)

CLEAN CYLINDER HEAD CRANKCASE BREATHER**NOTE**

This task is typical for cleaning engine cylinder head crankcase breathers.

1. Remove screw (1) from breather retaining plate (2).

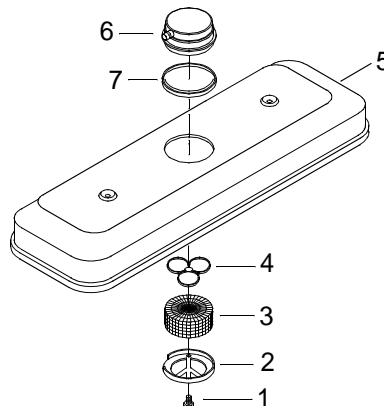

2. Remove retaining plate (2), breather element (3) and retainer (4) from cylinder head poppet valve rocker arm cover (5).
3. Remove breather housing (6) and seal (7) from cylinder head poppet valve rocker arm cover (5). Discard seal (7).

WARNING

**CHEMICAL****EYE PROTECTION**

4. Using cleaning cloth and clean lubricating oil, clean breather element (3).

WARNING

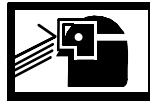
**CHEMICAL****EYE PROTECTION**

5. Using cleaning cloth and clean lubricating oil, clean breather housing (6).

WARNING

**CHEMICAL****EYE PROTECTION**

6. Using cleaning cloth, remove excess lubricating oil from breather element (3) and breather housing (6).
7. Using soft bristle brush, remove debris from retaining plate (2) and retainer (4).

WARNING

**CHEMICAL****EYE PROTECTION**

8. Dispose of contaminated cleaning cloths in accordance with local procedures.
9. Inspect breather element (3) for tearing. Replace damaged parts.
10. Install new seal (7) and breather housing (6) on cylinder head poppet valve rocker arm cover (5).
11. Position retainer (4), breather element (3) and retaining plate (2) on cylinder head poppet valve rocker arm cover (5).
12. Install screw (1) in retaining plate (2) and tighten.

WARNING

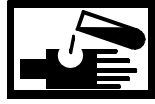
**CHEMICAL****EYE PROTECTION****SLICK FLOOR**

13. Clean up spilled fluid with a spill kit and dispose of spill kit waste in accordance with local procedures.
14. Install cylinder head poppet valve rocker arm cover. (WP 0043 00)
15. Install air inlet collector assembly. (WP 0104 00)
16. Install crankcase breather limiter assembly. (WP 0106 00)
17. Install engine hatch. (TM 55-1945-205-24-1-1)
18. Install operators cab. (TM 55-1945-205-24-1-1)
19. Install intake plenum assembly. (TM 55-1945-205-24-1-1)
20. Install main navigation mast. (TM 55-1945-205-24-1-1)
21. Install SINGARS antenna. (TM 11-5820-890-10-8)

END OF WORK PACKAGE

**DIRECT SUPPORT MAINTENANCE
CAUSEWAY FERRY
CYLINDER HEAD EXHAUST VALVES
ADJUSTMENT**

INITIAL SETUP:**Tools**

Tool Kit, General Mechanic's (Item 130, WP 0188 00)

Personnel Required

Engineer 88L (2)

References

TM 55-1945-205-10-1

Equipment Condition

Engine Cool To Touch

SINCGARS Antenna Removed. (TM 11-5820-890-10-8)

Main Navigation Mast Removed. (TM 55-1945-205-24-1-1)

Intake Plenum Assembly Removed. (TM 55-1945-205-24-1-1)

Operators Cab Removed. (TM 55-1945-205-24-1-1)

Engine Hatch Removed. (TM 55-1945-205-24-1-1)

Crankcase Breather Limiter Assembly Removed. (WP 0106 00)

Air Inlet Collector Assembly Removed. (WP 0104 00)

Cylinder Head Poppet Rocker Arm Covers Removed. (WP 0043 00)

ADJUST CYLINDER HEAD EXHAUST VALVES**NOTE**

This procedure is typical for all cylinder head exhaust valves on both the starboard and port engines.

1. Soldier number one rotates the crankshaft by turning the crankshaft pulley (1) clockwise.

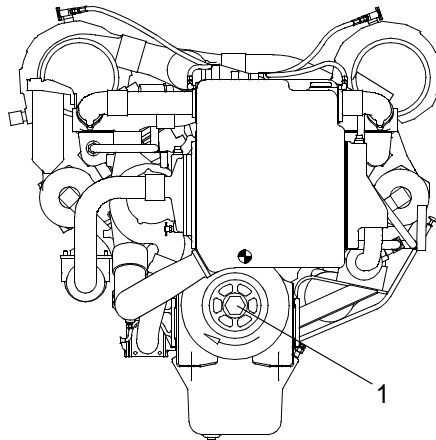

2. Second soldier holds the control lever (2) in the no fuel position and alerts soldier number one when the injector follower (3) is in the fully depressed position.

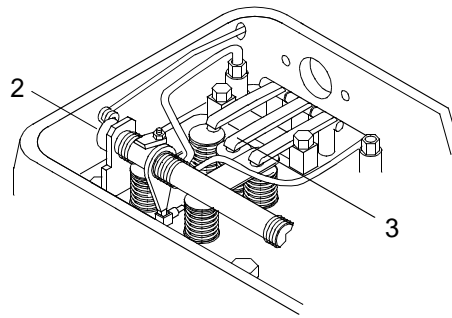

3. Loosen the lock nut (4) on exhaust valve rocker arm push rod (5).

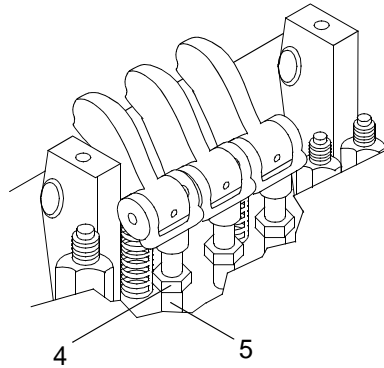

4. Insert a 0.016 in. (0.04064 mm) feeler gage between the valve bridge (6) and valve rocker arm pallet (7).

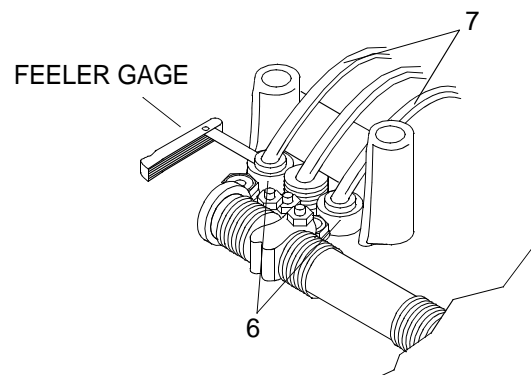

-
- Adjust the push rod (5) until a slight drag is felt on the feeler gage.

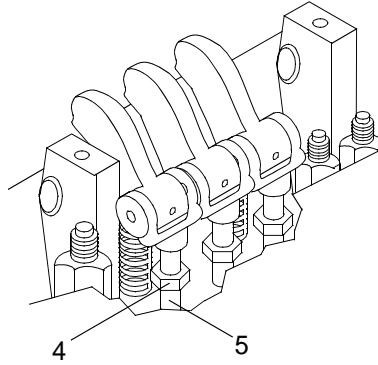

- Remove the feeler gage and tighten the pushrod lock nut (4)
- Recheck the clearance and repeat procedure on remaining valves.
- Start the engine and run it for 15 minutes. (TM 55-1945-205-10-1)
- Shut down engine. (TM 55-1945-205-10-1)

WARNING

**HOT AREA**

- Ensure engine cool to touch.
- Recheck valve clearance to verify that it has not changed. Re-adjust if necessary.
- Install cylinder head poppet valve rocker covers. (WP 0043 00)
- Install air inlet collector assembly. (WP 0104 00)
- Install crankcase breather limiter assembly. (WP 0106 00)
- Install engine hatch. (TM 55-1945-205-24-1-1)
- Install operators cab. (TM 55-1945-205-24-1-1)
- Install intake plenum assembly. (TM 55-1945-205-24-1-1)
- Install main navigation mast. (TM 55-1945-205-24-1-1)
- Install SINCGARS antenna. (TM 11-5820-890-10-8)
- Perform operational checks. (TM 55-1945-205-10-1)

END OF WORK PACKAGE

**DIRECT SUPPORT MAINTENANCE
CAUSEWAY FERRY
CYLINDER HEAD
REMOVAL AND INSTALLATION**

INITIAL SETUP:**Tools**

Tool Kit, General Mechanic's
(Item 130, WP 0188 00)
 Fixture, Lifting, Cylinder (Item 38, WP 0188 00)
 Wrench, Torque (0-175 ft lbs)
(Item 138, WP 0188 00)
 Wrench, Torque (10-250 in. lbs)
(Item 141, WP 0188 00)
 Wrench, Torque (150-750 in. lbs)
(Item 142, WP 0188 00)
 Wrench Set, Socket (3/8 in. sqdr.)
(Item 135, WP 0188 00)
 Indicator, Dial (Item 67, WP 0188 00)
 Pin, Straight, Headless (Item 91, WP 0188 00)
 Gloves, Chemical (Item 52, WP 0188 00)
 Goggles, Industrial (Item 54, WP 0188 00)
 Sling 5300 lbs 6 ft (Green) (Item 118, WP 0188 00)

Materials/Parts

Bolt
(72582)
NSN 5306-01-083-9374
PN 5148324
Qty 20
 Washer, Flat
(72582)
NSN 5310-01-084-2432
PN 5148310
Qty 20
 Lumber, Softwood, Dimension (2 in. X 4 in. X 6 ft
Min Wooden Blocks) (Item 23, WP 0187 00)
Qty 2
 Antiseize Compound (Item 6, WP 0187 00)
 Cloth, Cleaning (Item 13, WP 0187 00)

References

TM 55-1945-205-10-1

Equipment Condition

Engine Cool To Touch.
 SINCGARS Antenna Removed.
(TM 11-5820-890-10-8)
 Main Navigation Mast Removed.
(TM 55-1945-205-24-1-1)
 Intake Plenum Assembly Removed.
(TM 55-1945-205-24-1-1)
 Operators Cab Removed.
(TM 55-1945-205-24-1-1)
 Engine Hatch Removed. (TM 55-1945-205-24-1-1)
 Crankcase Breather Limiter Assembly Removed.
(WP 0106 00)
 Air Inlet Collector Assembly Removed.
(WP 0104 00)
 Turbochargers Removed. (WP 0114 00)
 Exhaust Manifold Removed. (WP 0163 00)
 Fresh Water Cooling System Bypass Hose
Removed. (WP 0148 00)
 Fresh Water Cooling System Port Thermostat
Housing Removed. (WP 0145 00)
 Fresh Water Cooling System Starboard Thermostat
Housing Removed. (WP 0144 00)
 Fresh Water Cooling System Port Water Outlet
Manifold Removed. (WP 0150 00)
 Fresh Water Cooling System Starboard Water
Outlet Manifold Removed. (WP 0151 00)
 Cylinder Head Poppet Valve Rocker Arm Covers
Removed. (WP 0043 00)
 Fuel Injector Control Tube Removed.
(WP 0086 00)

Personnel Required

Engineer 88L

REMOVE CYLINDER HEAD

1. Remove two connecting pins (1) and two washers (2) from shaft assembly (3) securing two fuel rods (4).

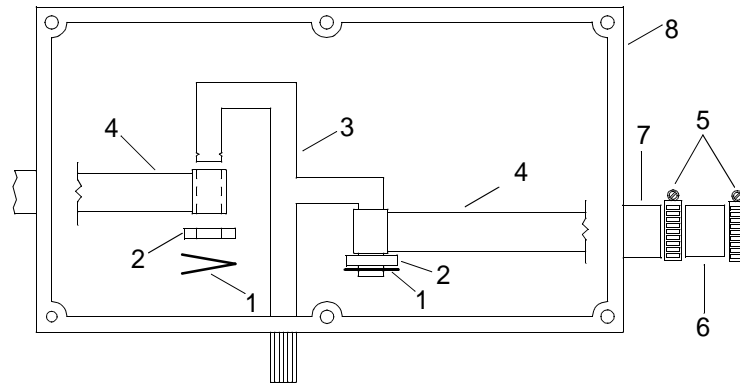

2. Remove two fuel rods (4).
3. Loosen four hose clamps (5) on the two fuel rod cover tube hoses (6).
4. Slide each fuel rod cover hose (6) and hose clamps (5) up on tube (7) in governor drive housing (8).
5. Remove the two fuel rods (4) through opening in governor drive housing (8).

CAUTION

**During installation, install the fuel pipes in their original location and orientation.
Failure to comply may cause premature engine failure or other damage
to equipment.**

6. Tag eight fuel pipes (9).

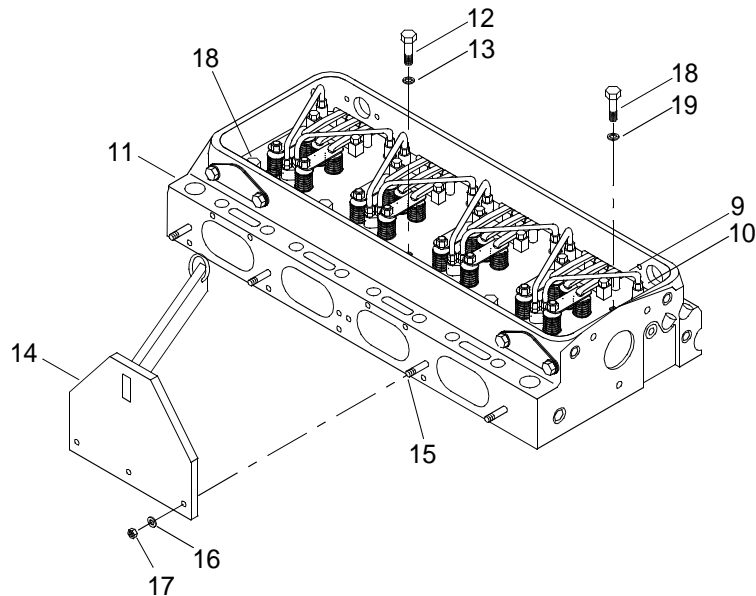

7. Loosen 16 fuel line nuts (10) and remove fuel pipes (9).

NOTE

Checking torque of cylinder head bolts before removing may reveal cause of any cylinder head failures.

8. Before removing cylinder head (11), check torque of 100 ft lbs (135.6 N-m) on each cylinder head bolt (12).

NOTE

Twelve point washer head bolts with LE head identification must be discarded upon removal.

9. Remove eight side bolts (12) and washers (13) and discard if necessary.
10. Install lifting tool (14) to three exhaust manifold studs (15) with washers (16) and nuts (17).
11. Attach lifting sling to lifting tool (14) and make taut.

NOTE

Twelve point washer head bolts with LE head identification must be discarded upon removal.

12. Remove two corner bolts (18) and washers (19) and discard if necessary.
13. Position wood wedges on bench for setting cylinder head (11).

WARNING

**HEAVY OBJECTS**

14. Lift and remove cylinder head (11).

WARNING

**HEAVY OBJECTS**

CAUTION

Cylinder head must be set on wooden blocks, positioned lengthwise, to prevent damage to cam followers.

15. Carefully position valve side of cylinder head (11) on bench on wood blocks.
16. Remove lifting tool (14) from cylinder head (11).

NOTE

Compression gaskets are color coded. Make note of color before removing gaskets.

17. Record color and remove four cylinder head compression gaskets (20).

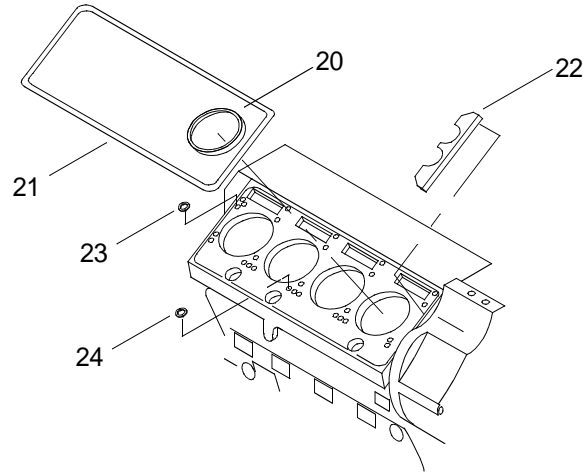

18. Remove cylinder block seal strip gasket (21).
19. Remove two support shims (22).
20. Remove oil seal (23).
21. Remove 16 water seals (24).

INSTALL CYLINDER HEAD**NOTE**

New compression gaskets are color coded red, black or no paint on outside diameter to identify thickness. Only one color coded gasket should be used under any one cylinder head.

An optional design, with no paint identification and of one thickness, compression gasket may be used. It may be intermixed on an engine under the same head with the current no paint compression gasket.

1. Install four cylinder head compression gaskets (20) of the same color removed.

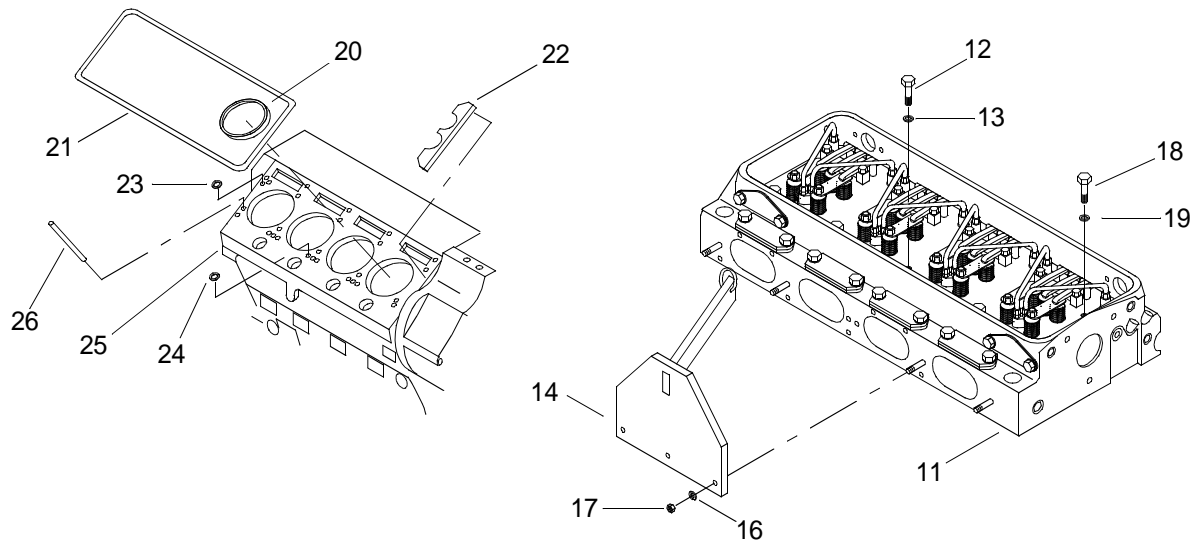

2. Remove adhesive paper and install support shims (22).
3. Position support shim (22), scallop at the rear of cylinder block (25), near oil supply hole.
4. Install oil seal (23), with color side facing away from cylinders.
5. Install 16 water seals (24).
6. Install seal strip gasket (21).
7. Install two headless pins (26) into cylinder head outboard corner bolt holes.

WARNING



HEAVY OBJECTS

8. Attach lifting tool (14) to cylinder head (11) and lift.
9. Wipe bottom of cylinder head (11) with a cleaning cloth.

CAUTION

Once the cylinder head has been positioned on the block over the guide studs, do not move it. Failure to comply may result in damage to equipment.

10. Visually check that all cylinder block compression gaskets (20), seals (21, 23, 24) and shims (22) are in proper position.
11. Lower cylinder head (11) over the guide studs (26) and onto the cylinder block (25).

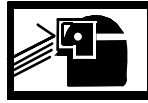
WARNING**CHEMICAL****EYE PROTECTION**

12. Apply antiseize compound to ten cylinder head attaching bolts (12) threads and underside of bolt heads.
13. Install eight cylinder head six point bolts (12) with flat washers (13) through each piloting sleeve at the inboard corners of the cylinder head.
14. Tighten bolts (12) finger tight.
15. Remove three nuts (17) and washers (16) and remove lifting tool (14).
16. Remove two headless pins (26).
17. Install two cylinder head six point bolts (18) with 11/16 in. washers (19) where guide studs (26) were removed.
18. Tighten bolts (18) finger tight.

NOTE

Failure to torque in sequence or repeat sequence may result in compression leaks when engine is placed in operation.

19. Using torque wrench, torque cylinder head bolts (12 and 18) in number order to 50 ft lbs (67.8 N-m).

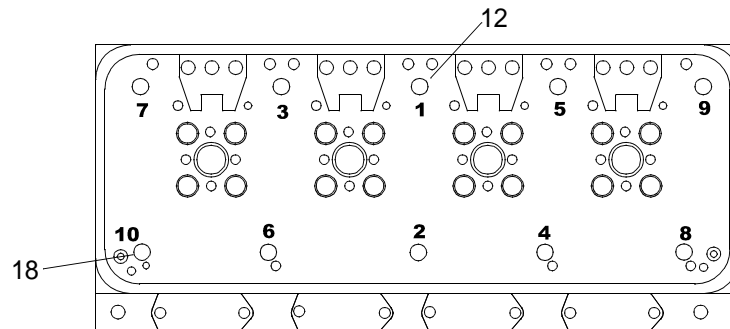
**NOTE**

Upon reaching the final torque, steady pressure for two or three seconds must be held to allow gaskets to seat properly.

20. Using torque wrench, torque bolts (12 and 18) to 100 ft lbs (135.6 N-m).
21. Repeat torque sequence to 100 ft lbs (135.6 N-m), to ensure first bolts torqued did not lose clamp load.
22. Mark position of each cylinder bolt head (12 and 18) in relation to the cylinder head profile face.
23. Tighten each cylinder bolt (12 and 18) in sequence, 90° with one pull of the wrench, from marked position.

CAUTION

To avoid confusion when tightening nuts, do not mix uncoated and coated fuel pipes on the same cylinder head. Do not exceed torque specifications. Failure to comply could result in damage to equipment.

NOTE

Fuel pipes may be reused if they are not bent, twisted, or restricted and flared ends are not distorted or damaged. When installing reusable lines, they must be installed in the same location and on the same connection from which they were removed.

24. Install eight fuel pipes (9) on cylinder head (11).

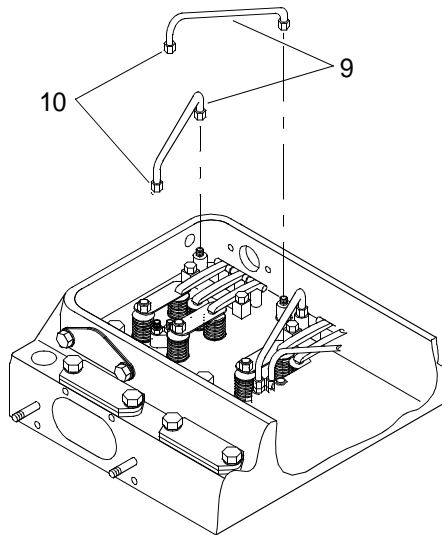

25. Torque nuts (10) to 130 in. lbs (14 N-m) using torque wrench.

26. Install fuel rods (4).

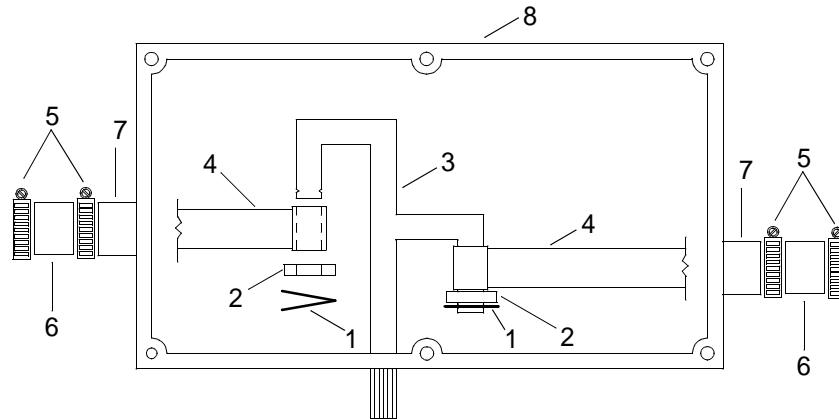

- a. Insert ends of the fuel rods (4) through governor housing (8) and through fuel rod cover tubes (7).
- b. Install ends of the fuel rods (4) on governor shaft assembly (3).
- c. Install two washers (2) and connecting pins (1) on governor shaft assembly (3).

27. Slide two fuel rod cover tube hoses (6) down on the cover tubes (7) attached to the cylinder heads.
28. Tighten four hose clamps (5).
29. Install fuel injector control tube. (WP 0086 00)
30. Install cylinder head poppet valve rocker arm covers. (WP 0043 00)
31. Install fresh water cooling system port water outlet manifold. (WP 0150 00)
32. Install fresh water cooling system starboard water outlet manifold. (WP 0151 00)
33. Install fresh water cooling system port thermostat housing. (WP 0145 00)
34. Install fresh water cooling system starboard thermostat housing. (WP 0144 00)
35. Install fresh water cooling system bypass hose. (WP 0148 00)
36. Install exhaust manifold. (WP 0163 00)
37. Install turbocharger. (WP 0114 00)
38. Install air inlet collector assembly. (WP 0104 00)
39. Install crankcase breather limiter. (WP 0106 00)
40. Install engine hatch. (TM 55-1945-205-24-1-1)
41. Install operators cab. (TM 55-1945-205-24-1-1)
42. Install air intake plenum assembly. (TM 55-1945-205-24-1-1)
43. Install main navigation mast. (TM 55-1945-205-24-1-1)
44. Install SINCGARS antenna. (TM 11-5820-890-10-8)
45. Perform operational check. (TM 55-1945-205-10-1)

END OF WORK PACKAGE

**DIRECT SUPPORT MAINTENANCE
CAUSEWAY FERRY
REAR LIFTING BRACKETS
REPLACEMENT**

INITIAL SETUP:**Tools**

Tool Kit, General Mechanic's (Item 130, WP 0188 00)

Materials/Parts

Bracket
(72582)
PN 23501711
Gasket
(72582)
PN 5117332

Personnel Required

Engineer 88L

References

TM 55-1945-205-10-1

Equipment Condition

SINGARS Antenna Removed. (TM 11-5820-890-10-8)
Main Mast Navigation Assembly Removed. (TM 55-1945-205-24-1-1)
Intake Plenum or Operators Cab Removed. (TM 55-1945-205-24-1-1)
Engine Hatch Removed. (TM 55-1945-205-24-1-1)
Engine Cool To Touch.
Crankcase Breather Limiter Assembly Removed. (WP 0106 00)
Air Inlet Collector Assembly Removed. (WP 0104 00)

REMOVE REAR LIFTING BRACKETS

1. Loosen eight band clamps (1) from Y-duct (2), angle tube (3) and four hoses (4) between the turbochargers (5) and air inlet housing (6).

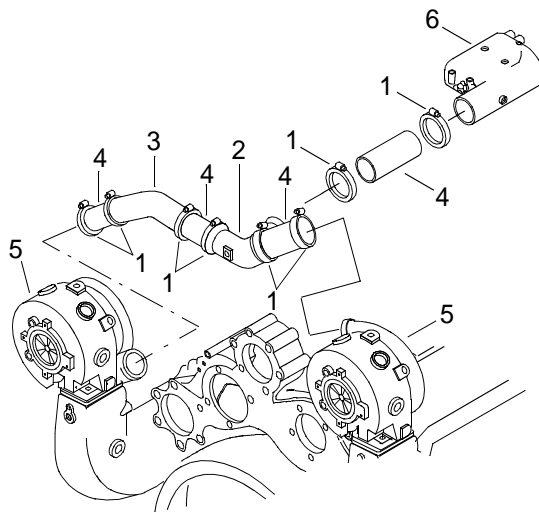

2. Remove the Y-duct (2) angle tube (3), and four hoses (4) from between turbochargers (5) and air inlet housing (6).
3. Remove two hex nuts (7) and lock washers (8) from cap screws (9).

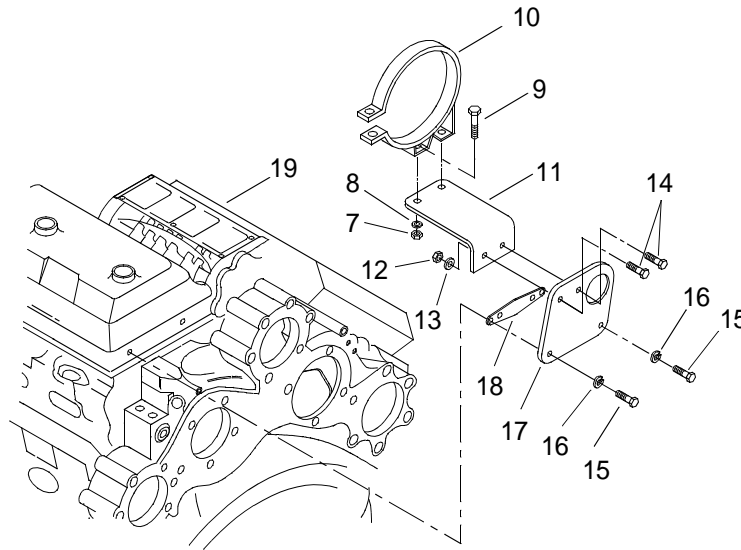

4. Remove band bracket (10) from mounting bracket (11).
5. Remove two hex nuts (12) and lock washers (13) from cap screw (14).
6. Remove mounting bracket (11).
7. Remove two cap screws (15) and lock washers (16) from lifting bracket (17).
8. Remove lifting bracket (17) and discard.
9. Remove gasket (18) from engine (19) and discard.

INSTALL REAR LIFTING BRACKETS

1. Position new gasket (18) on engine (19).
2. Position new lifting bracket (17) on engine (19).
3. Install two cap screws (15) and lock washers (16) on lifting bracket (17) and tighten.
4. Position mounting bracket (11) on lifting bracket (17).
5. Install cap screws (14) on mounting bracket (11).
6. Install two hex nuts (12) and lock washers (13) on cap screw (14) and tighten.
7. Position band bracket (10) on mounting bracket (11).
8. Install two cap screws (9) on band bracket (10).
9. Install two hex nuts (7) and lock washers (8) on cap screws (9) and tighten.
10. Install the Y-duct (2), angle tube (3) and four hoses (4) between turbochargers (5) and air inlet housing (6).

-
11. Install eight band clamps (1) on Y-duct (2), angle tube (3) and four hoses (4) between the turbochargers (5) and air inlet housing (6).
 12. Tighten eight band clamps (1).
 13. Install air inlet collector assembly. (WP 0104 00)
 14. Install crankcase breather limiter assembly. (WP 0106 00)
 15. Install engine hatch. (TM 55-1945-205-24-1-1)
 16. Install intake plenum or operators cab. (TM 55-1945-205-24-1-1)
 17. Install main mast navigation assembly. (TM 55-1945-205-24-1-1)
 18. Install SINCGARS antenna. (TM 11-5820-890-10-8)
 19. Perform operational check. (TM 55-1945-205-10-1)

END OF WORK PACKAGE

**GENERAL SUPPORT MAINTENANCE
CAUSEWAY FERRY
CYLINDER HEAD POPPET VALVE ROCKER ARM
REMOVAL, CLEANING, INSPECTION AND INSTALLATION**

INITIAL SETUP:**Tools**

Tool Kit, General Mechanic's (Item 130, WP 0188 00)
Caliper Set, Micrometer, Outside (Item 22, WP 0188 00)
Caliper Set, Micrometer, Inside (Item 23, WP 0188 00)
Gloves, Chemical (Item 52, WP 0188 00)
Goggles, Industrial (Item 54, WP 0188 00)
Compressor Unit, Reciprocating, Power Drive (Item 27, WP 0188 00)

Materials/Parts

Wire, Nonelectrical (Item 40, WP 0187 00)
Cleaning Compound (Item 10, WP 0187 00)
Oil, Lubricating, Engine, 10W (Item 25, WP 0187 00)

Personnel Required

Engineer 88L

Equipment Condition

Engine Cool To Touch.
SINGARS Antenna Removed. (TM 11-5820-890-10-8)
Main Navigation Mast Removed. (TM 55-1945-205-24-1-1)
Intake Plenum Assembly Removed. (TM 55-1945-205-24-1-1)
Operators Cab Removed. (TM 55-1945-205-24-1-1)
Engine Hatch Removed. (TM 55-1945-205-24-1-1)
Crankcase Breather Limiter Assembly Removed. (WP 0106 00)
Air Inlet Collector Assembly Removed. (WP 0104 00)
Air Intake Housing Removed. (WP 0103 00)
Cylinder Head Poppet Valve Rocker Arm Cover Removed. (WP 0043 00)
Fuel Manifolds Removed (WP 0050 00)

REMOVE CYLINDER HEAD POPPET VALVE ROCKER ARM

WARNING

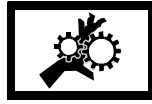
**MOVING PARTS**

When barring over or “bumping” the starter, personnel should keep their hands and clothing away from moving parts of the engine as there is a possibility the engine could start and injury to personnel could occur.

Do not bar the crankshaft in a left hand direction of rotation with a wrench or barring tool on the crankshaft bolt. The bolt could be loosened and the pulley, belt or vibration damper could fly off, resulting in serious injury to personnel.

NOTE

This procedure is typical for all rocker arms on both the starboard and port engines.

1. Turn the crankshaft, or crank the engine with the starting motor, to bring the injector and valve rocker arms in line horizontally.
2. Remove the two bolts (1) which secure the rocker arm shaft brackets (2) to the cylinder head (3).

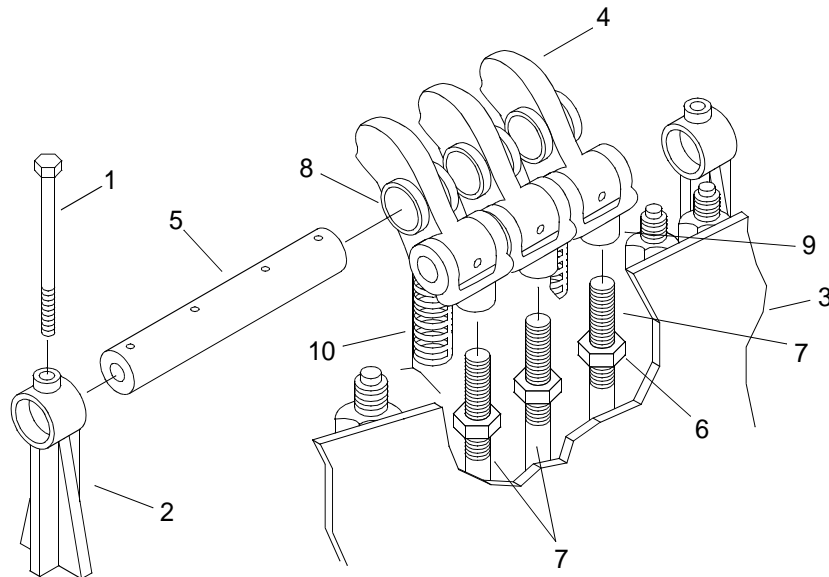

3. Remove the two brackets (2) from the cylinder head (3).

CAUTION

Do not force rocker arms all the way back with rocker arm shaft in place as this could impose a load on the pushrods and bend them.

4. Move the three rocker arms (4) up and toward center of engine.
5. Remove rocker arm shaft (5).

- Loosen the lock nuts (6) at the upper end of the pushrods (7).

NOTE

If the rocker arms and shafts from two or more cylinders are to be removed, tag them so they can be installed in their original positions.

- Unscrew the pushrods (7) from the rocker arms (4).

CLEAN ROCKER ARMS AND SHAFT

WARNING



CHEMICAL



EYE PROTECTION

- Wash the rocker arms, shaft, brackets and bolts with cleaning compound.
- Use 0.032 in. nonelectrical wire to clean out the drilled oil passages in rocker arms and rocker arm shafts.

WARNING



EYE PROTECTION

Do not exceed 40 PSI (276 kPa) when using compressed air for drying components. All personnel must wear safety goggles during this procedure. Failure to observe this precaution could result in serious injury.

- Dry parts using compressed air.

INSPECT ROCKER ARMS AND SHAFT

- Inspect the rocker arm shaft (5) and rocker arm bushings (8) for wear. Replace damaged parts.

NOTE

The outside diameter of the rocker arm shaft should measure between 0.8735 in. minimum and 0.8740 in. maximum.

- Using an outside micrometer, measure the outside diameter of the rocker arm shaft (5). Replace defective rocker arm shaft (5) as necessary.

NOTE

The inside diameter of the rocker arm bushing should measure between 0.8750 in. minimum and 0.8760 in. maximum.

- Using an inside micrometer, measure the inside diameter of the rocker arm bushing (8). Replace defective rocker arm bushing (8) as necessary.

NOTE

A difference of 0.004 in. is allowed between the rocker arm shaft and the rocker arm bushing.

4. Subtract the diameter of the rocker arm shaft (5) from the diameter of the rocker arm bushing (8). Replace defective rocker arm shaft (5) and rocker arm bushings (8) as a set as necessary.
5. Inspect the rocker arm shaft brackets (5) for cracks. Install new bracket if damaged.

INSTALL ROCKER ARM**NOTE**

The injector rocker arm (center arm of the group) is slightly different from the exhaust valve rocker arms. The boss for the shaft of the end rocker arms is longer on one side only. The extended boss side of the exhaust rocker arms must face toward the middle (injector) rocker arm. Exhaust rocker arms also have a flat spot beneath the rocker shaft hole.

If a rocker arm is damaged or breaks, the push rod should always be replaced when a new rocker arm is installed.

1. To provide sufficient clearance between the exhaust valve and the piston when the crankshaft is rotated, thread each of the three rocker arms (4) onto pushrods (7) until end of push rod is flush with the inner side of clevis yoke (9).

WARNING

**EYE PROTECTION**

2. Coat shaft (5) with clean engine lubricating oil and slide it through three rocker arms (4).
3. Install two brackets (2), one over each end of shaft (5), with finished face of the bracket next to rocker arms (4).
4. Install the rocker arm bracket bolts (5) by inserting bolts through the bracket (6) and shaft (9).
5. Position rocker arms (8) down on valve bridge (10).
6. Hold each push rod (7) while tightening three lock nuts (6).
7. Install fuel manifolds. (WP 0050 00)
8. Install cylinder head poppet valve rocker arm cover. (WP 0043 00)
9. Install air inlet collector assembly. (WP 0104 00)
10. Install crankcase breather limiter assembly. (WP 0106 00)
11. Install air intake housing. (WP 0103 00)
12. Install engine hatch. (TM 55-1945-205-24-1-1)

-
13. Install operators cab. (TM 55-1945-205-24-1-1)
 14. Install intake plenum assembly. (TM 55-1945-205-24-1-1)
 15. Install main navigation mast. (TM 55-1945-205-24-1-1)
 16. Install SINGARS antenna. (TM 11-5820-890-10-8)

END OF WORK PACKAGE

**GENERAL SUPPORT MAINTENANCE
CAUSEWAY FERRY
CYLINDER HEAD POPPET VALVE ROCKER ARM
REPAIR**

INITIAL SETUP:**Tools**

Tool Kit, General Mechanic's (Item 130, WP 0188 00)
Press, Arbor, Hand Operated (Item 97, WP 0188 00)
Apron, Utility (Item 8, WP 0188 00)
Gloves, Chemical (Item 52, WP 0188 00)
Goggles, Industrial (Item 54, WP 0188 00)
Compressor Unit, Reciprocating, Power Drive (Item 27, WP 0188 00)

Materials/Parts

Bearing, Sleeve
(72582)
NSN 3120-00-661-7616
PN 5150311
Bushing, Sleeve
(72582)
NSN 3120-00-662-1651
PN 5123700
Pin, Hollow
(72582)
NSN 5315-00-662-9093
PN 5150314
Bearing, Sleeve
(72582)
NSN 3120-00-661-7640
PN 5150318
Cleaner (Item 8, WP 0187 00)
Cloth, Cleaning (Item 13, WP 0187 00)

Personnel Required

Engineer 88L

DISASSEMBLE ENGINE POPPET VALVE ROCKER ARM**NOTE**

This procedure is typical for all poppet valve rocker arms on both the starboard and port engines.

1. Place rocker arm assembly (1) in arbor press.

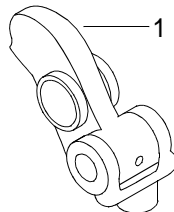

WARNING

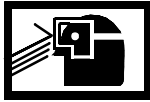

EYE PROTECTION

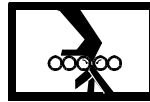

MOVING PARTS

2. Using arbor press, press pin (2) out of bushing (3). Discard pin (2).

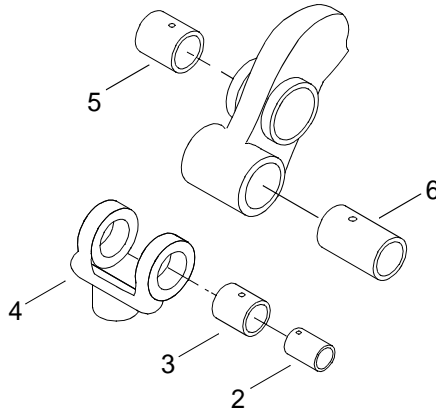

WARNING

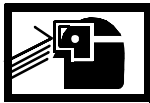

EYE PROTECTION

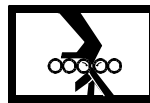

MOVING PARTS

3. Using arbor press, press bushing (3) out of clevis (4). Discard bushing (3).

WARNING



EYE PROTECTION

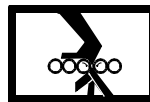

MOVING PARTS

4. Using arbor press, press bearing sleeve (5) from clevis bearing orifice (6). Discard sleeve (5).

CLEAN POPPET VALVE ROCKER ARM AND BUSHINGS

WARNING



EYE PROTECTION

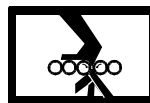

MOVING PARTS

1. Using cleaner, clean the poppet rocker arm assembly (1), clevis (4) and clevis bearing orifice (6).

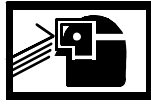
WARNING**EYE PROTECTION**

**Do not exceed 40 PSI (276 kPa) when using compressed air for drying components.
Failure to observe this precaution could result in serious injury.**

- Using compressed air, dry poppet valve rocker arm (1) and clevis bearing orifice (6).

INSPECT CLEVIS BUSHING

- Inspect the clevis bearing orifice (6) for stress cracks, nicks, abrasions and other damage. Replace defective part.
- Inspect the clevis (4) for damage. Discard defective part.

ASSEMBLE ROCKER ARM CLEVIS AND BUSHINGS

- Place rocker arm body (1) in arbor press.

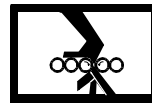
WARNING**EYE PROTECTION****MOVING PARTS**

- Using arbor press, press new bearing sleeve (5) in clevis bearing orifice (6) of rocker arm (1).

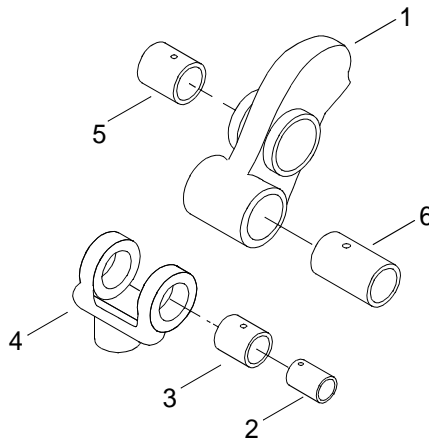

- Position clevis (4) over clevis bearing orifice (6).

WARNING

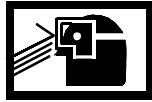
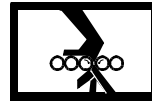
**EYE PROTECTION****MOVING PARTS**

- Using arbor press, press new bushing (3) into clevis (4).

WARNING

**EYE PROTECTION****MOVING PARTS**

- Using arbor press, press new pin (2) into bushing (3).
- Remove rocker arm assembly from arbor press.

END OF WORK PACKAGE

**DIRECT SUPPORT MAINTENANCE
CAUSEWAY FERRY
CYLINDER HEAD FUEL MANIFOLD
REMOVAL, CLEANING, INSPECTION AND INSTALLATION**

INITIAL SETUP:**Tools**

Tool Kit, General Mechanic's (Item 130, WP 0188 00)
 Apron, Utility (Item 8, WP 0188 00)
 Gloves, Chemical (Item 52, WP 0188 00)
 Goggles, Industrial (Item 54, WP 0188 00)
 Compressor Unit, Reciprocating, Power Drive (Item 27, WP 0188 00)
 Wrench, Torque (150-750 in. lbs) (Item 142, WP 0188 00)
 Wrench, Torque (10-250 in. lbs) (Item 141, WP 0188 00)
 Wrench Set, Socket (3/8 in. sqdr.) (Item 135, WP 0188 00)

Materials/Parts

Seal, Nonmetallic
 (72582)
 NSN 5330-01-346-0486
 PN 8928676
 Qty 16
 Cleaner (Item 8, WP 0187 00)

Personnel Required

Engineer 88L

References

TM 55-1945-205-10-1

Equipment Condition

Engine Cool To Touch.
 SINGARS Antenna Removed. (TM 11-5820-890-10-8)
 Main Navigation Mast Removed. (TM 55-1945-205-24-1-1)
 Intake Plenum Assembly Removed. (TM 55-1945-205-24-1-1)
 Operators Cab Removed. (TM 55-1945-205-24-1-1)
 Powered Section Module Engine Hatch Removed. (TM 55-1945-205-24-1-1)
 Crankcase Breather Limiter Assembly Removed. (WP 0106 00)
 Air Inlet Collector Assembly Removed. (WP 0104 00)
 Cylinder Head Poppet Valve Rocker Arm Cover Removed. (WP 0043 00)

REMOVE FUEL MANIFOLD CONNECTIONS

WARNING



CHEMICAL



EYE PROTECTION

NOTE

This task is typical for each fuel manifold connection group and for both sides of the engine.

1. Remove metal tube assembly (1).

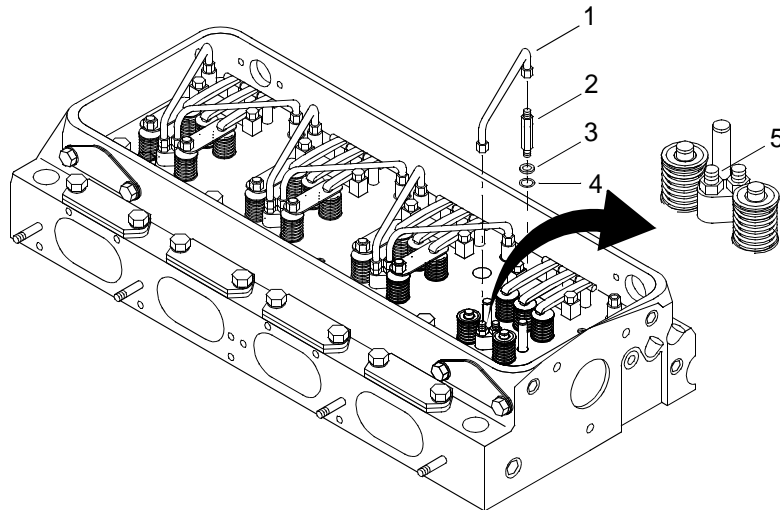

2. Remove manifold (2), flat washer (3) and nonmetallic seal (4). Discard nonmetallic seal (4).

CLEAN FUEL MANIFOLD CONNECTIONS

WARNING

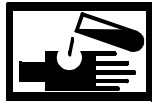

CHEMICAL



EYE PROTECTION

1. Clean metal tube assembly (1), manifold (2) and flat washers (3) using solution of cleaner and water.

WARNING



EYE PROTECTION

**Do not exceed 40 PSI (276 kPa) when using compressed air for drying components.
Failure to comply could result in serious injury to personnel**

2. Using dry compressed air, dry metal tube assembly (1), manifold (2) and flat washers (3).

INSPECT FUEL MANIFOLD CONNECTIONS

1. Inspect metal tube assembly (1) for cracking, dents or corrosion. Replace defective part.
2. Inspect manifold (2) threads for signs of galling, cracks or corrosion. Replace defective part.
3. Inspect threaded cylinder head boss (5) for signs of galling, cracks or corrosion. Replace defective part.

INSTALL FUEL MANIFOLD CONNECTIONS

1. Place flat washer (3) and new nonmetallic seal (4) on manifold (2).
2. Install manifold (2) in threaded cylinder head boss and tighten.
3. Using torque wrench and socket set, torque manifold (2) to 480-540 in. lbs (54-61 N-m).
4. Install metal tube assembly (1).
5. Using torque wrench and socket set, torque nuts to 120 in. lbs (14 N-m).
6. Install cylinder head poppet valve rocker arm cover. (WP 0043 00)
7. Install air inlet collector assembly. (WP 0104 00)
8. Install crankcase breather limiter assembly. (WP 0106 00)
9. Install engine hatch. (TM 55-1945-205-24-1-1)
10. Install operators cab. (TM 55-1945-205-24-1-1)
11. Install intake plenum assembly. (TM 55-1945-205-24-1-1)
12. Install main navigation mast. (TM 55-1945-205-24-1-1)
13. Install SINGARS antenna. (TM 11-5820-890-10-8)
14. Perform operational check. (TM 55-1945-205-10-1)

END OF WORK PACKAGE

**GENERAL SUPPORT MAINTENANCE
CAUSEWAY FERRY
CYLINDER HEAD
REPAIR**

INITIAL SETUP:**Tools**

Tool Kit, General Mechanic's (Item 130, WP 0188 00)
Apron, Utility (Item 8, WP 0188 00)
Gloves, Chemical (Item 52, WP 0188 00)
Goggles, Industrial (Item 54, WP 0188 00)
Protectors, Hearing (Item 98, WP 0188 00)
Fixture, Lifting, Cylinder (Item 38, WP 0188 00)
Fixture, Test, Head (Item 39, WP 0188 00)
Rule, Steel Machinist's (Item 110, WP 0188 00)
Indicator, Dial (Item 67, WP 0188 00)
Caliper Set, Micrometer, Outside (Item 22, WP 0188 00)
Caliper Set, Micrometer, Inside (Item 23, WP 0188 00)
Installer, Water Nozzle (Item 75, WP 0188 00)
Brush, Stencil (Soft Bristle) (Item 20, WP 0188 00)
Wrench, Torque (10-250 in. lbs) (Item 141, WP 0188 00)
Wrench, Torque (150-750 in. lbs) (Item 142, WP 0188 00)
Wrench Set, Socket (3/8 in. sqdr.) (Item 135, WP 0188 00)
Degreaser (Tank, Cleaning) (Item 32, WP 0188 00)

Materials/Parts

Set, Gasket
(72582)
NSN 5330-01-053-1845
PN 5199674
Cleaning Compound (Item 10, WP 0187 00)
Fuel, Diesel (Item 19, WP 0187 00)
Sealing Compound, (Pipe Sealant) (Item 29, WP 0187 00)
Cloth, Abrasive (Item 12, WP 0187 00)
Cloth, Cleaning (Item 13, WP 0187 00)
Boots, Disposable (Item 7, WP 0187 00)

Personnel Required

Engineer 88L

DISASSEMBLE CYLINDER HEAD

1. Remove fuel manifolds. (WP 0050 00)
2. Remove fuel system injector control tube. (WP 0086 00)
3. Remove fuel system injectors. (WP 0091 00)
4. Remove cylinder head poppet valve rocker arm. (WP 0048 00)
5. Remove cylinder head valve guide bridges. (WP 0057 00)
6. Remove cylinder head cam followers. (WP 0052 00)

7. Remove cylinder head push rods. (WP 0053 00)
8. Remove cylinder head exhaust valves. (WP 0054 00)
9. Remove cylinder head valve guides. (WP 0058 00)
10. Remove cylinder head valve seat inserts. (WP 0056 00)
11. Remove engine elbows, tees, adaptors and plugs. (WP 0180 00)
12. Remove four bolts (1) and lock washers (2).

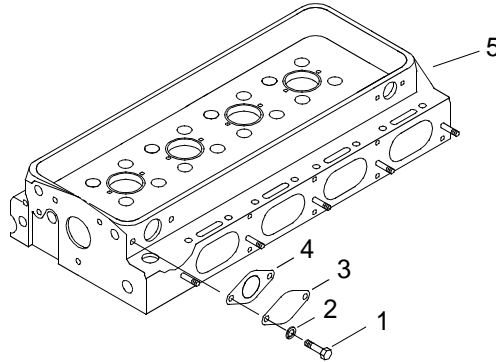

13. Remove two cover plates (3) and gaskets (4) from front of cylinder head (5). Discard gaskets (4).

CLEAN CYLINDER HEAD

WARNING



EYE PROTECTION

1. Remove all remaining gasket material from cylinder head (5) using scraper.

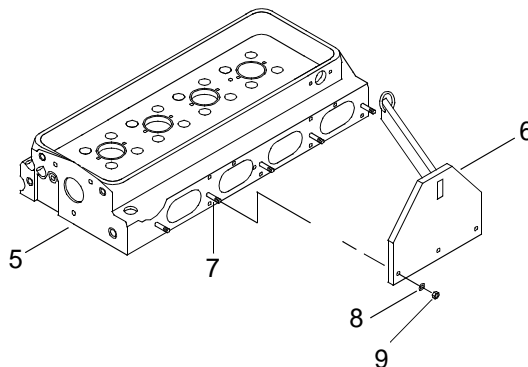

2. Position lifting fixture (6) on exhaust manifold studs (7).
3. Install three washers (8) and nuts (9) on exhaust manifold studs (7). Tighten nuts (9).

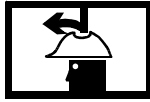
WARNING

HELMET PROTECTION



HEAVY PARTS

4. Place cylinder head (5) in degreaser tank using lifting fixture (6) and crane.

WARNING

HOT AREA



EYE PROTECTION



CHEMICAL

5. Clean cylinder head (5) using powdered cleaning compound.

WARNING

HELMET PROTECTION



HEAVY PARTS

6. Remove cylinder head (5) from cleaning cabinet using lifting fixture (6) and crane.

WARNING

HOT AREA

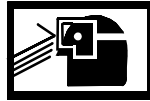

EYE PROTECTION

7. Rinse cylinder block (5) with clear hot water or steam clean.

WARNING

EAR PROTECTION



EYE PROTECTION

Do not exceed 40 PSI (276 kPa) when drying parts with compressed air. Failure to comply could result in serious injury to personnel.

8. Dry cylinder head (5) with compressed air.

INSPECT CYLINDER HEAD

1. Inspect cover plate (3) for cracks and warping. Replaced damaged parts.
2. Inspect cylinder head (5) for cracks using magnetic particle method or equivalent. Discard cylinder head if cracks are found.
3. Inspect bottom of cylinder head (5) for flatness.

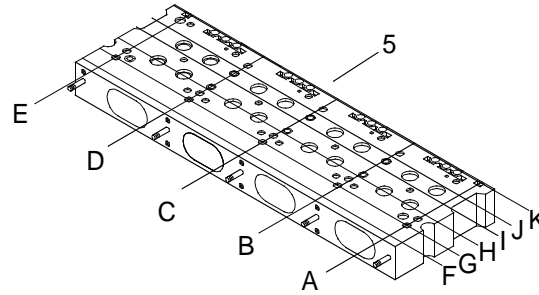

- a. Check for warpage across cylinder head (5) at lines A, B, C, D and E using a heavy straight edge and feeler gage, verifying warpage does not exceed 0.0040 in. (0.01 cm). Discard cylinder head if limits are exceeded.
 - b. Check for longitudinal warpage on cylinder head (5) at lines F, G, H, I, J and K using a heavy straight edge and feeler gage, verifying warpage does not exceed 0.0080 in. (0.02 cm). Discard cylinder head if limits are exceeded.
4. Inspect bottom of cylinder head (5) for pitting. Discard pitted cylinder head.
 5. Inspect cam follower bores (10) for scoring or wear.

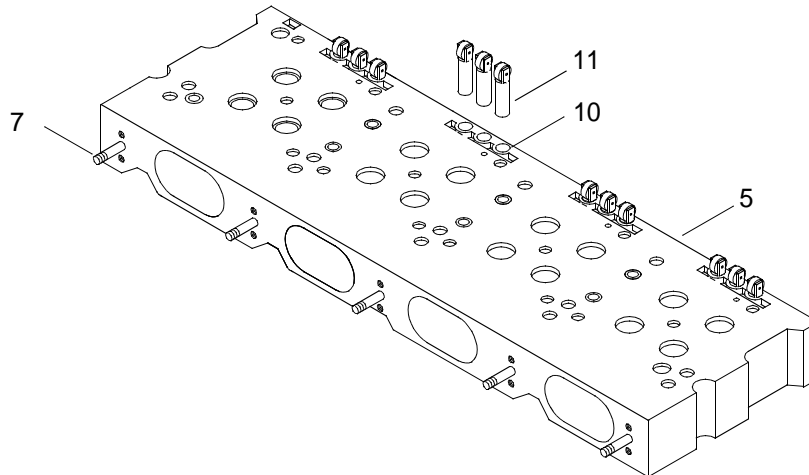

WARNING

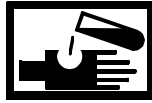
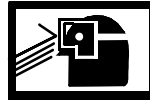
**CHEMICAL****EYE PROTECTION**

6. Remove light scoring using abrasive cloth wet with diesel fuel. Discard cylinder head with scoring that cannot be removed.
7. Measure and record cam follower bore (10) diameters using an inside micrometer. Measurement should be between 1.0620 – 1.0630 in. (2.6924 – 2.6949 cm).
8. Measure and record diameter of cam followers (11) using outside micrometer. Measurement should be between 1.0600 – 1.0610 in. (2.6975 – 2.7000 cm).
9. Verify that clearance between cam follower(s) and cam follower bore(s) (10) does not exceed 0.002 in. (0.00508 cm). Discard defective part.

NOTE

The cam follower bore to cam follower clearance for a used cylinder head and a used cam follower must not exceed 0.006 in. (0.01524 cm).

10. Inspect mounting studs (7) for stripped threads, bending or cracks. Replace damaged studs.

TEST CYLINDER HEAD

WARNING

If cracks are visible in cylinder head, do not perform pressure check. Failure to comply could result in serious injury or death to personnel.

NOTE

Dummy injectors may be made from old injectors nuts and bodies. The injector spray tips are not necessary.

The following steps are typical for each dummy injector.

1. Install four dummy injectors (12) into cylinder head (5).

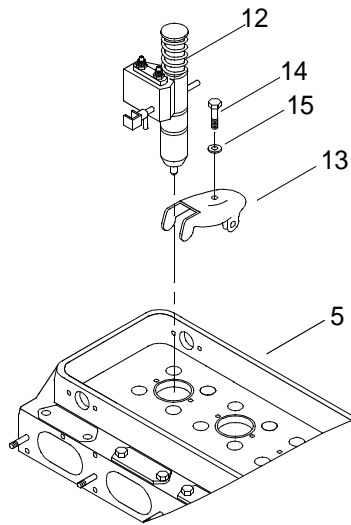

2. Install clamp (13) on each dummy injector (12).
3. Install bolt (14) with convex washer (15) in clamp (13).
4. Using torque wrench and socket set, tighten bolt (14) to 240-300 in. lbs (27-34 N-m).
5. Position four gaskets (16) on cylinder head (5).

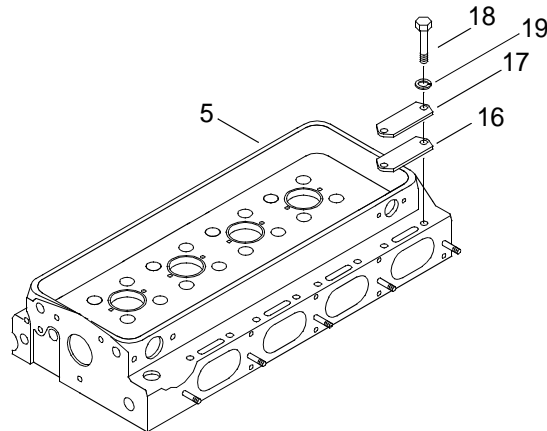

6. Position four cover plates (17) on cylinder head (5).
7. Install eight bolts (18) with copper washers (19) securing coverplates (17) to cylinder head (5).

8. Align pressure checking tool test fixture (20) on water inlet ports (21).

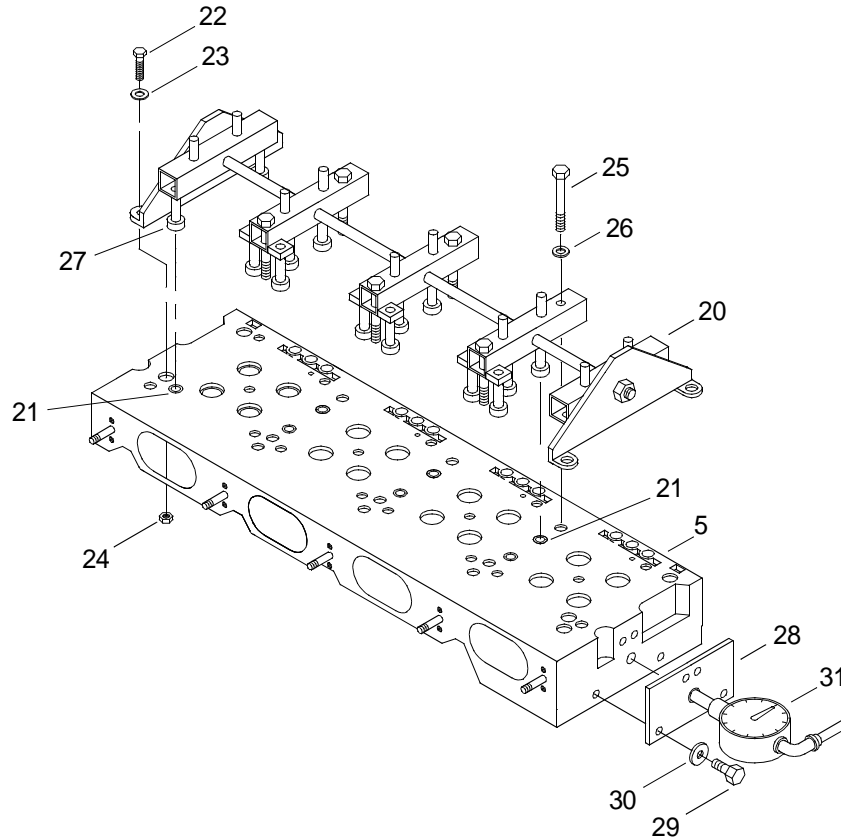

9. Install four bolts (22) with washers (23) in fixture (20).
10. Install nuts (24) finger tight on bolts (22).
11. Install six hold down bolts (25) with washers (26).

NOTE

Do not overtighten hold down bolts on test fixture. Overtightening will distort rubber stoppers and seal outer diameter of water nozzles, preventing the detection of a leak.

12. Tighten bolts (25), using torque wrench and socket set, evenly until rubber stoppers (27) start to distort, at approximately 60 in. lbs (6.78 N-m).
13. Tighten nuts (24).
14. Position pressure checking tool air supply plate (28) onto thermostat end of cylinder head (5).
15. Install four bolts (29) with washers (30) into plate (28). Tighten bolts.
16. Connect air hose with dial gauge (31) to air supply plate (28).

WARNING

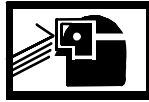
**EYE PROTECTION**

17. Apply 40 PSI (275.79 kPa) to cylinder head (5).
18. Check for leakage around water inlet ports (21).

WARNING

**HOT AREA****HEAVY PARTS**

19. Using lifting fixture (6) and crane, place cylinder head (5) into water tank heated to 180° - 200°F (82° - 93°C).
20. Observe water tank for 20 minutes watching for bubbles indicating a leak or crack.

WARNING

**HOT AREA****HEAVY PARTS**

21. If leak is observed, using lifting fixture (6) and crane, remove cylinder head (5) from water tank and check test fixture (20) for proper seating.

WARNING

**HOT AREA****HEAVY PARTS**

22. If test fixture is seated properly, using lifting fixture (6) and appropriate lifting device, return cylinder head (5) to water tank and observe for bubbles. If bubbles are observed, replace cylinder head.

WARNING

**HEAVY OBJECTS**

23. Remove cylinder head (5) from water tank using lifting fixture (6).

24. Disconnect air supply hose with dial gauge (31) from air supply plate (28).
25. Remove bolts (29) with washers (30) from air supply plate (28).
26. Remove air supply plate (28) from cylinder head (5).
27. Remove four nuts (24), bolts (22) with washers (23) from fixture (20).
28. Remove six hold down bolts (25) with washers (26) from fixture (20).
29. Remove test fixture (20) from cylinder head (5).
30. Remove four bolts (14) with convex washers (15) from clamps (13).

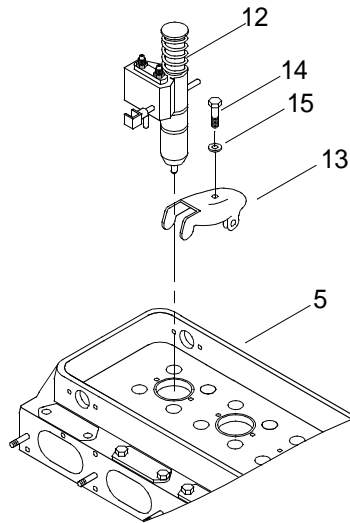

31. Remove clamps (13) from four dummy injectors (12).
32. Remove dummy injectors (12) from cylinder head (5).
33. Remove three nuts (9) and washers (8) and remove lifting fixture (6).

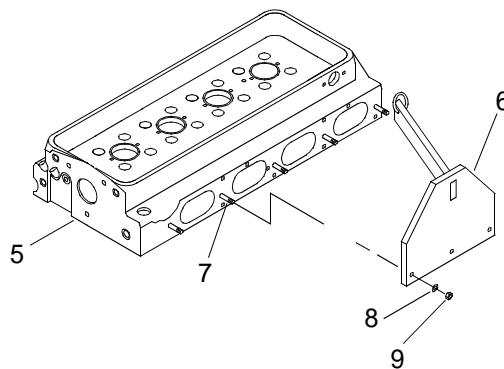

34. Remove eight bolts (18) with copper washers (19) securing coverplates (17) to cylinder head (5).

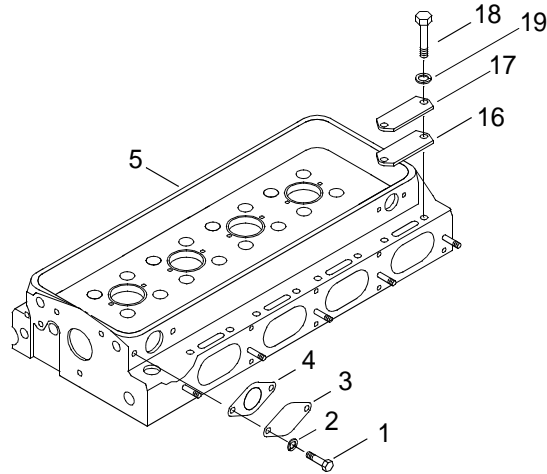

35. Remove four cover plates (17) from cylinder head (5).

36. Remove four gaskets (16) from cylinder head (5).

ASSEMBLE CYLINDER HEAD

1. Install two new gaskets (4) and cover plates (3) on cylinder head water inlet ports (5).
2. Install four bolts (1) with lock washers (2). Tighten bolts (1).
3. Install engine elbows, tees, adaptors and plugs. (WP 0180 00)
4. Install cylinder head valve guides. (WP 0058 00)
5. Install cylinder head valve seat inserts. (WP 0056 00)
6. Install cylinder head exhaust valves. (WP 0054 00)
7. Install cylinder head push rods. (WP 0053 00)
8. Install cylinder head cam followers. (WP 0052 00)
9. Install cylinder head valve guide bridges. (WP 0057 00)
10. Install poppet valve rocker arms. (WP 0048 00)
11. Install fuel system injectors. (WP 0091 00)
12. Install fuel system injector control. (WP 0086 00)
13. Install fuel manifolds. (WP 0050 00)

END OF WORK PACKAGE

**GENERAL SUPPORT MAINTENANCE
CAUSEWAY FERRY
CYLINDER HEAD CAM FOLLOWER
REPLACEMENT**

INITIAL SETUP:**Tools**

Tool Kit, General Mechanic's (Item 130, WP 0188 00)
Gloves, Chemical (Item 52, WP 0188 00)
Goggles, Industrial (Item 54, WP 0188 00)
Wrench, Torque (150-750 in. lbs) (Item 142, WP 0188 00)
Wrench Set, Socket (3/8 in. sqdr.) (Item 135, WP 0188 00)

Materials/Parts

Cam Follower
(72582)
PN 8924439
Oil, Lubricating, Engine, 10W (Item 25, WP 0187 00)
Cloth, Cleaning (Item 13, WP 0187 00)
Lumber, Softwood, Dimension (2 in. X 4 in. X 6 ft Min Wooden Blocks) (Item 23, WP 0187 00)
Qty 2

Personnel Required

Engineer 88L

Equipment Condition

Cylinder Head Poppet Valve Rocker Arms Removed. (WP 0048 00)
Cylinder Head Fuel Manifold Removed. (WP 0050 00)
Cylinder Head Valve Guide Bridge Removed. (WP 0057 00)

REMOVE CYLINDER HEAD CAM FOLLOWER

WARNING



HEAVY PARTS

NOTE

This following procedure is typical for the removal of all cam followers.

1. Position cylinder head (1) on two wooden wedges (2).

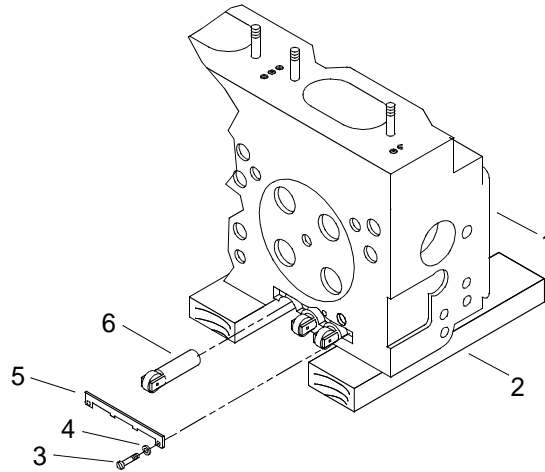

2. Remove two bolts (3) and lock washers (4) from cam follower guide (5).
3. Remove cam follower guide (5) from cylinder head (1).
4. Remove the cam follower (6) from cylinder head (1) and discard.

INSTALL CYLINDER HEAD CAM FOLLOWER

WARNING



CHEMICAL

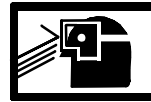

EYE PROTECTION

1. Using cleaning cloth and lubricating oil, remove preservative from new cam follower (6).

WARNING



CHEMICAL



EYE PROTECTION

2. Using cleaning cloth, dry cam follower (6).

WARNING



CHEMICAL



EYE PROTECTION



HOT AREA

3. Immerse cam follower (6) in lubricating oil heated to 100 - 125°F (38 - 52°C) for one hour.

WARNING



CHEMICAL



EYE PROTECTION



HOT AREA

4. Rotate cam roller every fifteen minutes.

WARNING



CHEMICAL



EYE PROTECTION



HOT AREA

5. Remove cam follower (6) from heated lubricating oil.

WARNING



CHEMICAL



EYE PROTECTION

NOTE

Oil hole in cam follower must face away from exhaust valve.

6. Install cam follower (6) into cylinder head (1).
7. Install cam follower guide (5) on cylinder head (1).
8. Install two lock washers (4) and bolts (3) securing cam follower guide (5) to cylinder head (1).
9. Using torque wrench and socket set, tighten bolts (3) to 180 in. lbs (20.34 N-m).

10. Using feeler gage, verify minimum clearance between cam follower guide (5) and cam follower (6) is 0.0005 in. (0.00127 cm).

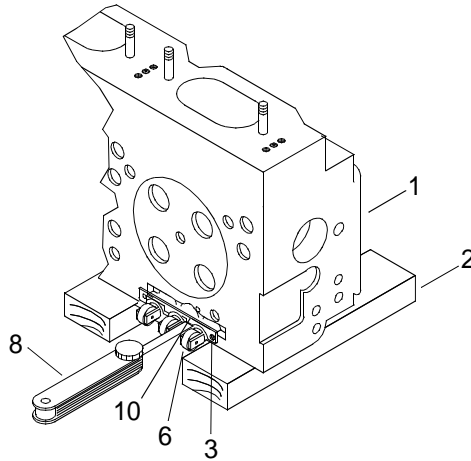

11. If clearance between cam follower guide (5) and cam follower is less than 0.0005 in. (0.00127 cm), loosen two bolts (6).
12. Using brass drift and hammer, tap each corner of cam follower guide (5) to obtain required clearance.
13. Using feeler gage, verify minimum clearance between cam follower guide (5) and cam follower (6) is 0.0005 in. (0.00127 cm).
14. Using torque wrench and socket set, tighten bolts (6) to 180 in. lbs (20.34 N-m).
15. Using feeler gage, verify minimum clearance between cam follower guide (5) and cam follower (6) is 0.0005 in. (0.00127 cm).

WARNING

**HEAVY PARTS**

16. Remove cylinder head (1) from two wooden wedges (2).
17. Install cylinder head valve guide bridge. (WP 0057 00)
18. Install cylinder head poppet valve rocker arms. (WP 0048 00)
19. Install cylinder head fuel manifold. (WP 0050 00)

END OF WORK PACKAGE

**GENERAL SUPPORT MAINTENANCE
CAUSEWAY FERRY
CYLINDER HEAD PUSH ROD
REPLACEMENT**

INITIAL SETUP:**Tools**

Tool Kit, General Mechanic's (Item 130, WP 0188 00)
 Tester, Spring (Item 123, WP 0188 00)
 Gloves, Chemical (Item 52, WP 0188 00)
 Goggles, Industrial (Item 54, WP 0188 00)
 Pliers, Retaining Ring (Item 95, WP 0188 00)

Materials/Parts

Ring, Retaining
 (72582)
 NSN 5365-00-282-5031
 PN 5150303
 Cloth, Cleaning (Item 13, WP 0187 00)
 Oil, Lubricating, Engine, 40W (Item 27, WP 0187 00)

Personnel Required

Engineer 88L

Equipment Condition

Cylinder Head Fuel Manifold Removed. (WP 0050 00)
 Cylinder Head Poppet Valve Rocker Arm Removed. (WP 0048 00)
 Cylinder Head Valve Guide Bridge Removed. (WP 0057 00)
 Cylinder Head Cam Follower Removed. (WP 0052 00)

REMOVE CYLINDER HEAD PUSH ROD**NOTE**

The following procedure is typical for the removal of all cylinder head push rods.

1. Remove push rod (1) assembly from cylinder head (2).

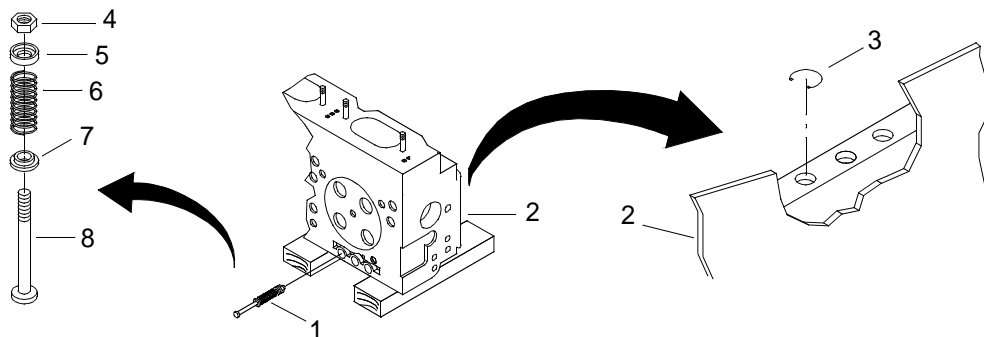

2. Using retaining ring pliers, remove retaining ring (3) from cylinder head (2) and discard.
3. Remove hex nut (4), retainer (5), spring (6) and spring seat (7) from push rod (8).

WARNING

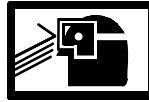
**CHEMICAL****EYE PROTECTION**

4. Using cleaning cloth and clean lubricating oil, remove debris from spring (6), hex nut (4), retainer (5), spring (6), spring seat (7) and push rod (8).

WARNING

**CHEMICAL****EYE PROTECTION**

5. Using cleaning cloth, dry spring (6), hex nut (4), retainer (5), spring (6), spring seat (7) and push rod (8).
6. Inspect spring (6), hex nut (4), retainer (5), spring (6), spring seat (7) and push rod (8) for wear or damage. Discard defective part.
7. Using spring tester, compress spring (6) to a length of 2.1406 in. (5.4371 cm).
8. Using spring tester, verify minimum load of 250 lb (113.398 kg). Discard defective part.

WARNING

**CHEMICAL****EYE PROTECTION**

9. Dispose of contaminated cleaning cloths in accordance with local procedures.

INSTALL CYLINDER HEAD PUSH ROD

1. Install spring seat (7), spring (6), retainer (5) and hex nut (4) on push rod. (8).
2. Tighten hex nut (4).
3. Install new retaining ring (3) in cylinder head (2).
4. Install push rod (1) assembly in cylinder head (2).
5. Install cylinder head cam follower. (WP 0052 00)
6. Install cylinder head valve guide bridge. (WP 0057 00)
7. Install cylinder head poppet valve rocker arm. (WP 0048 00)
8. Install cylinder head fuel manifold. (WP 0050 00)

END OF WORK PACKAGE

**GENERAL SUPPORT MAINTENANCE
CAUSEWAY FERRY
CYLINDER HEAD EXHAUST VALVE
REMOVAL AND INSTALLATION**

INITIAL SETUP:**Tools**

Tool Kit, General Mechanic's (Item 130, WP 0188 00)
Compressor, Valve Spring (Item 29, WP 0188 00)
Tester, Spring (Item 123, WP 0188 00)
Apron, Utility (Item 8, WP 0188 00)
Gloves, Chemical (Item 52, WP 0188 00)
Goggles, Industrial (Item 54, WP 0188 00)
Indicator, Dial (Item 67, WP 0188 00)
Checker, Valve Spring (Item 25, WP 0188 00)

Materials/Parts

Cloth, Cleaning (Item 13, WP 0187 00)
Cleaner (Item 8, WP 0187 00)
Lumber, Softwood, Dimension (2 in. X 4 in. X 6 ft Min Wooden Blocks) (Item 23, WP 0187 00)
Qty 2
Oil, Lubricating, Engine, 10W (Item 25, WP 0187 00)
Tape, Pressure Sensitive Adhesive (Item 36, WP 0187 00)

Personnel Required

Engineer 88L

Equipment Condition

Cylinder Head Poppet Valve Rocker Arms Removed. (WP 0048 00)
Cylinder Head Valve Guide Bridge. (WP 0057 00)
Fuel Injectors Removed. (WP 0091 00)
Cylinder Head Cam Followers Removed. (WP 0052 00)
Cylinder Head Push Rods Removed. (WP 0053 00)

REMOVE CYLINDER HEAD EXHAUST VALVE**NOTE**

The following procedure is typical for removal and installation of all thirty-two cylinder head exhaust valves on both port and starboard engines.

1. Support cylinder head (1), with bottom side down, on two wood wedges.

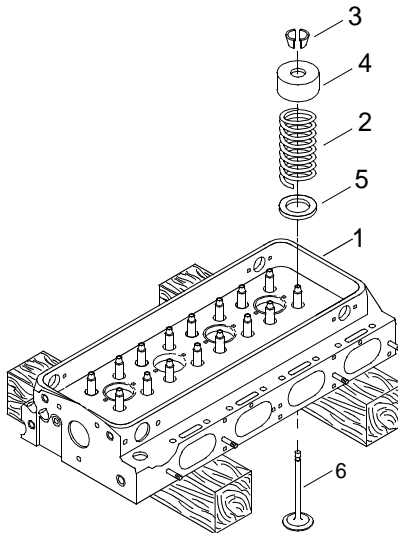

NOTE

If reusing exhaust valves, number each valve for proper installation.

2. Using valve spring compressor, compress exhaust valve spring (2).
3. Remove two retaining wedges (3).
4. Release pressure on spring (2) and remove spring compressor.
5. Remove retaining cap (4), spring (2) and spring seat (5).
6. Remove exhaust valve (6).
7. Tag exhaust valves (6) for reuse.
8. Repeat steps 2 thru 7 on remaining exhaust valves (6).

ASSEMBLE CYLINDER HEAD EXHAUST VALVE

NOTE

Valve guides must be clean before installing exhaust valves.

1. Set cylinder head (1) on its side.

WARNING

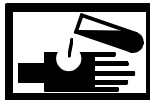

CHEMICAL



EYE PROTECTION

2. Lubricate valve (6) with lubricating oil.

NOTE

When using original exhaust valves, install them into the same location from which removed.

3. Install exhaust valve (6) into cylinder head (1) and temporarily secure with tape.

WARNING**HEAVY OBJECTS**

4. Set cylinder head (1) with exhaust valve (6) on top of wooden blocks.
5. Install valve spring seat (5), spring (2) and retaining cap (4).

NOTE

Compress valve spring only enough to permit installation of the spring cap.

6. Compress spring (2), using valve spring compressor.
7. Install two locking wedges (3).
8. Release pressure on spring (2) and remove spring compressor.
9. Check exhaust valve start of opening, using spring checking gauge. Note gauge reading the moment the exhaust valve begins to open. The minimum allowable pressure must not be less than 20 lb (9.08 kg). Replace springs not meeting this requirement.

NOTE

The exhaust valves are allowed a clearance of 0.006 in. (0.01524 cm) above the fire deck to 0.023 in. (0.05842 cm) below the fire deck.

10. Using a dial indicator, measure the exhaust valve (6) clearance to the fire deck. Replace any exhaust valves (6) that fail.

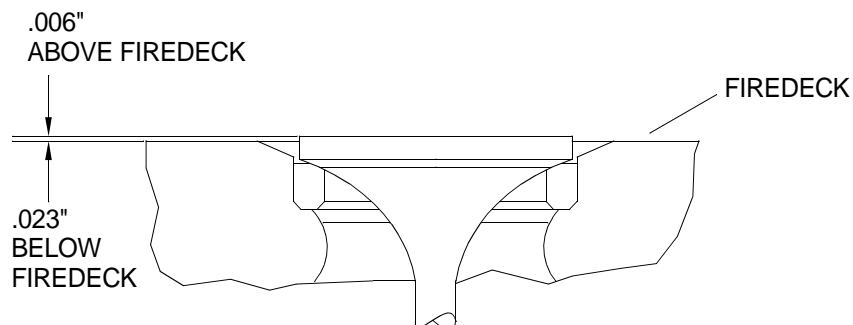

11. Install cylinder head push rods. (WP 0053 00)
12. Install cylinder head cam follower. (WP 0052 00)

13. Install fuel injectors. (WP 0091 00)

14. Install cylinder head valve guide bridge. (WP 0057 00)

15. Install cylinder head poppet valve rocker arm. (WP 0048 00)

END OF WORK PACKAGE

**GENERAL SUPPORT MAINTENANCE
CAUSEWAY FERRY
CYLINDER HEAD EXHAUST VALVE
REPAIR**

INITIAL SETUP:**Tools**

Tool Kit, General Mechanic's (Item 130, WP 0188 00)
Grinding Machine, Valve Face (Item 57, WP 0188 00)
Tester, Spring (Item 123, WP 0188 00)
Caliper Set, Micrometer, Outside (Item 22, WP 0188 00)
Brush, Cleaning, Valve Guide (Item 19, WP 0188 00)
Brush, Wire Scratch (Item 21, WP 0188 00)
Apron, Utility (Item 8, WP 0188 00)
Gloves, Chemical (Item 52, WP 0188 00)
Goggles, Industrial (Item 54, WP 0188 00)

Materials/Parts

Cleaning Compound (Item 10, WP 0187 00)
Cloth, Cleaning (Item 13, WP 0187 00)

Personnel Required

Engineer 88L

CLEAN CYLINDER HEAD EXHAUST VALVE COMPONENTS

WARNING

**CHEMICAL****EYE PROTECTION**

1. Using cleaning cloth and cleaning compound, clean debris from valve lock (1), spring cap (2), valve spring (3), spring seat (4) and valve (5).

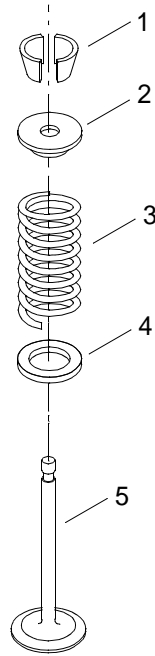
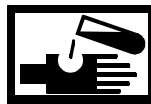
**WARNING**

CHEMICAL



EYE PROTECTION

**Do not exceed 30 PSI (206 kPa) when using compressed air for drying components.
Failure to comply could result in serious injury to personnel.**

2. Dry all metal components using compressed air.

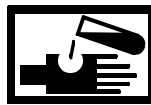
WARNING

CHEMICAL

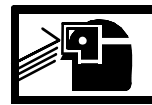

EYE PROTECTION

3. Clean any carbon deposit from valve stems (5) with a wire brush and wash in cleaning compound.

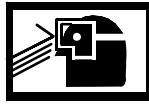
WARNING**EYE PROTECTION**

**Do not exceed 30 PSI (206 kPa) when using compressed air for drying components.
Failure to comply could result in serious injury to personnel.**

4. Dry valve stems (5) using compressed air.
5. Clean inside diameter of valve guides, using a valve guide brush, to remove gum and/or carbon deposits.

INSPECT CYLINDER HEAD EXHAUST VALVE COMPONENTS

1. Inspect valve lock (1) for cracks or fractures. Discard defective part.
2. Inspect spring cap (2) for cracks and wear. Replace defective part.
3. Inspect spring (3) for pitting or fractures. Discard defective part.
4. Using outside micrometer, verify outside diameter of spring (3) is 0.9531 in. (2.42 cm). Discard defective part.
5. Using spring tester, compress spring (3) to 1.80 in. (4.572 cm).
6. Verify minimum of 25 lb (11.35 kg) required to compress valve spring (3). Discard defective part.
7. Inspect exhaust valve seat for cracks and wear. Replace defective parts.
8. Using machinists rule, check the thickness of valve (5) edge, thickness should be 0.031 in. (0.0787 cm). Discard defective part.

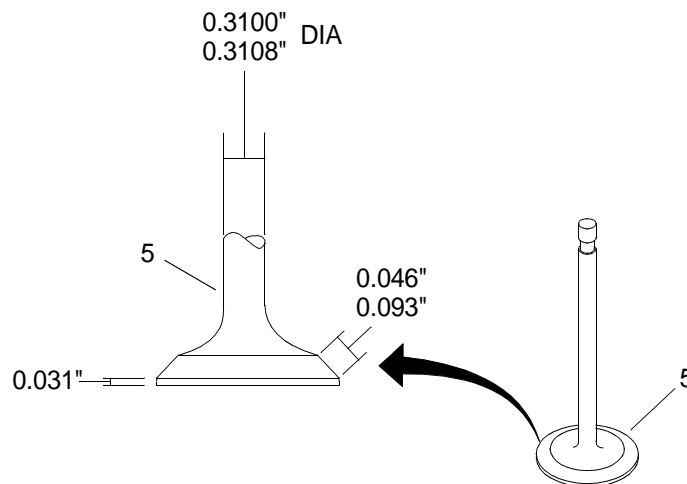

9. Using an outside micrometer, check the diameter of the valve stem (5), diameter should be 0.3100 to 0.3108 in. (0.7874 to 0.7894 cm). Repair or replace damaged parts.
10. Using a machinist ruler, check the width of the valve face (5), width should be 0.046 to 0.093 in. (0.1168 to 0.2362 cm). Repair or replace damaged parts.

11. Inspect valve (5) head for warping. Discard defective part.
12. Inspect valve (5) stem for scuff marks, scratches and wear. Discard defective part.
13. Inspect valve (5) face for ridges, cracks and pitting. Repair or replace damaged part.

REPAIR CYLINDER HEAD EXHAUST VALVE COMPONENTS

WARNING

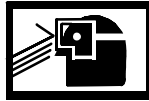

EYE PROTECTION

CAUTION

Valves and valve seat inserts must be ground and the same time. Failure to comply will result in damage to the valve.

1. Using valve grinding machine, and a 31° grinding stone, grind off as little metal as possible to repair valve (5) face.

WARNING



CHEMICAL



EYE PROTECTION

2. Using cleaning cloth and cleaner, clean valve (5).
3. Inspect valve (5) face for ridges, cracks and pitting.
4. Repeat steps 1 and 2 if required.
5. Using machinists rule, check the thickness of valve (5) edge, thickness should be 0.031 in. (0.0787 cm). Discard defective part.
6. Using an outside micrometer, check the diameter of the valve stem (5), diameter should be 0.3100 to 0.3108 in. (0.7874 to 0.7894 cm). Repair or replace damaged parts.
7. Using a machinist ruler, check the width of the valve face (5), width should be 0.046 to 0.093 in. (0.1168 to 0.2362 cm). Repair or replace damaged parts.

WARNING



CHEMICAL



EYE PROTECTION

8. Dispose of contaminated cloths in accordance with local procedures.

END OF WORK PACKAGE

**GENERAL SUPPORT MAINTENANCE
CAUSEWAY FERRY
CYLINDER HEAD EXHAUST VALVE SEAT INSERTS
REPLACEMENT**

INITIAL SETUP:**Tools**

Tool Kit, General Mechanic's (Item 130, WP 0188 00)
Remover, Valve Seat Insert (Item 107, WP 0188 00)
Collet, Valve Seat Insert Remover (Item 26, WP 0188 00)
Fixture, Lifting, Cylinder (Item 38, WP 0188 00)
Replacing Tool, Engine Valve Seat Insert (Item 108, WP 0188 00)
Apron, Utility (Item 8, WP 0188 00)
Gloves, Chemical (Item 52, WP 0188 00)
Goggles, Industrial (Item 54, WP 0188 00)
Caliper Set, Micrometer, Outside (Item 22, WP 0188 00)
Gage, Dial, Valve Seat (Item 45, WP 0188 00)
Grinder, Valve Seat (Item 56, WP 0188 00)
Adaptor Kit, Valve Seat Grinder (Item 1, WP 0188 00)
Stone, Abrasive, Cylinder Hone (Item 121, WP 0188 00)

Materials/Parts

Insert, Valve Guide
(72582)
NSN 2815-01-055-7659
PN 5148490
Cleaner (Item 8, WP 0187 00)
Cloth, Cleaning (Item 13, WP 0187 00)
Fuel, Diesel (Item 19, WP 0187 00)
Lumber, Softwood, Dimension (2 in. X 4 in. X 6 ft Min Wooden Blocks) (Item 23, WP 0187 00)
Qty 2

Personnel Required

Engineer 88L

Equipment Condition

Cylinder Head Fuel Manifolds Removed. (WP 0050 00)
Fuel System Injector Control Removed. (WP 0086 00)
Fuel System Injectors Removed. (WP 0091 00)
Cylinder Head Poppet Valve Rocker Arms Removed. (WP 0048 00)
Cylinder Head Valve Guide Bridges Removed. (WP 0057 00)
Cylinder Head Cam Followers Removed. (WP 0052 00)
Cylinder Head Push Rods Removed. (WP 0053 00)
Cylinder Head Exhaust Valves Removed. (WP 0054 00)

REMOVE CYLINDER HEAD EXHAUST VALVE SEAT INSERTS**NOTE**

This task is typical for removal and installation of cylinder head exhaust valve seat inserts
in both port and starboard engines.

1. Support cylinder head (1) on two wooden blocks (2).

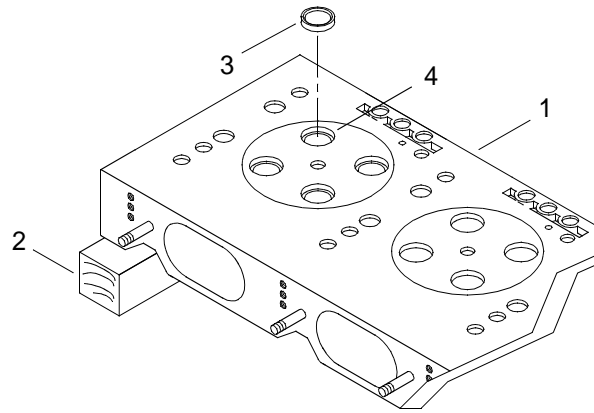

- Using exhaust valve seat insert remover and collet, remove exhaust valve seat insert (3) from valve seat insert counterbore (4) and discard.

INSTALL CYLINDER HEAD EXHAUST VALVE SEAT INSERTS

WARNING



CHEMICAL

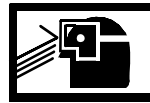

EYE PROTECTION

- Using cleaning cloth and cleaner, clean valve insert counterbore (4) and new insert (3).

WARNING

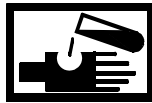

CHEMICAL



EYE PROTECTION

- Dispose of contaminated cleaning cloth in accordance with local procedures.

WARNING



EYE PROTECTION

**Do not exceed 40 PSI (275.79 kPa) when using compressed air for drying parts.
Failure to comply could result in serious injury to personnel.**

- Using compressed air, dry counterbore (3) and insert (2).

4. Install cylinder lifting fixture (5) on cylinder head exhaust manifold studs (6).

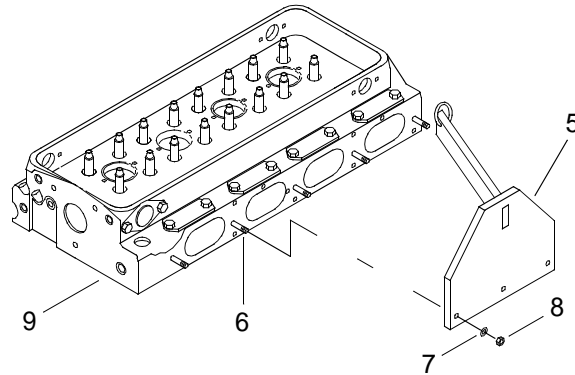

5. Install three washers (7) and nuts (8) on cylinder head exhaust manifold studs (9). Tighten nuts (8).

WARNING



HOT AREA



HEAVY OBJECTS

6. Using cylinder lifting fixture (5), place cylinder head (9) in water heated to 180° - 220°F (82° - 93°C) for 30 minutes.

WARNING



HEAVY OBJECTS

7. Using cylinder lifting fixture (5), remove cylinder head (9) from water and position on bench, bottom side up.

WARNING



HOT AREA

8. Remove three nuts (8) and washers (7) from cylinder head exhaust manifold studs (6).

WARNING

**HOT AREA**

9. Remove cylinder lifting fixture (5) from cylinder head exhaust manifold studs (6).
10. Verify that the thickness of the valve seat insert (3) is 0.268 to 0.272 in. (0.6807 to 0.6909 cm).

WARNING

**HOT AREA**

CAUTION

The cylinder head is heated to so that it expands, allowing the valve seat inserts to go in with out damaging the cylinder head. It will be necessary to heat the cylinder head more than once to complete the installation of all 16 valve seat inserts. Failure to comply could result in damage to cylinder head.

11. Using replacing tool and hammer, drive inserts (2) into cylinder head (1).

WARNING

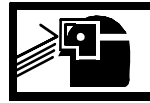
**CHEMICAL****EYE PROTECTION**

12. Using cleaning cloth and diesel fuel, wipe valve seat insert (3).
13. Using cleaning cloth, dry valve seat insert (3).
14. Install pilot tool from adaptor kit in cylinder head (1).

CAUTION

At no time during the valve grinding process should the grinding stone contact the cylinder head casting. If the grinding stone contacts the cylinder head casting, the valve seat is unserviceable and must be replaced prior to proceeding. Failure to comply will result in damage to cylinder head casting.

15. Using a valve seat grinder and a 31° grinding wheel from the adaptor kit, apply a 31° bevel on the valve seat insert (3).

WARNING

**CHEMICAL****EYE PROTECTION**

16. Using cleaning cloth and diesel fuel, wipe valve seat insert (3).
17. Using cleaning cloth, dry valve seat insert (3).
18. Using a valve seat grinder and a 60° grinding wheel from the adaptor kit, apply a 60° bevel on the inside of valve seat insert (3).

WARNING

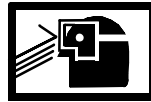
**CHEMICAL****EYE PROTECTION**

19. Using cleaning cloth and diesel fuel, wipe valve seat insert (3).
20. Using cleaning cloth, dry valve seat insert (3).
21. Using a valve seat grinder and a 15° grinding wheel from the adaptor kit, apply a 15° bevel on the outside of valve seat insert (3).

WARNING

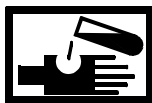
**CHEMICAL****EYE PROTECTION**

22. Using cleaning cloth and diesel fuel, wipe valve seat insert (3).
23. Using cleaning cloth, dry valve seat insert (3).
24. Remove pilot from cylinder head (1).
25. Using a valve seat dial gage, check the concentricity of valve seat insert. Total run-out allowed is 0.002 in. (0.005 cm).
26. If total run-out exceeds 0.002 in. (0.005 cm), check for worn or damaged valve guides.
27. If valve guides are serviceable, regrind valve seats (3).

WARNING

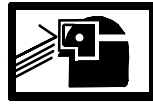
**CHEMICAL****EYE PROTECTION****SLICK FLOOR**

28. Dispose of contaminated cleaning and drying cloths in accordance with local procedures.
29. Install cylinder head exhaust valves. (WP 0054 00)
30. Install cylinder head push rods. (WP 0053 00)
31. Install cylinder head cam followers. (WP 0052 00)
32. Install cylinder head valve guide bridges. (WP 0057 00)
33. Install cylinder head poppet valve rocker arm and shaft. (WP 0048 00)
34. Install fuel injectors. (WP 0091 00)
35. Install fuel injector control. (WP 0086 00)
36. Install cylinder head fuel manifolds. (WP 0050 00)

END OF WORK PACKAGE

**GENERAL SUPPORT MAINTENANCE
CAUSEWAY FERRY
CYLINDER HEAD VALVE GUIDE BRIDGE
REPLACEMENT**

INITIAL SETUP:**Tools**

Tool Kit, General Mechanic's (Item 130, WP 0188 00)

Materials/Parts

Guide

(72582)

NSN 2815-01-160-8271

PN 5148491

Screw, Set

(72582)

NSN 5305-00-884-4803

PN 5129101

Nut, Hex

(72582)

NSN 5310-00-270-7111

PN 5151601

Personnel Required

Engineer 88L

Equipment Condition

Fuel Manifolds Removed. (WP 0050 00)

Cylinder Head Poppet Valve Rocker Arms Removed. (WP 0048 00)

REMOVE CYLINDER HEAD EXHAUST VALVE GUIDE BRIDGE**NOTE**

The following procedure is typical for removal and installation of cylinder head exhaust valve guide bridges.

1. Remove cylinder head exhaust valve guide bridge (1) from cylinder head valve guide (2).

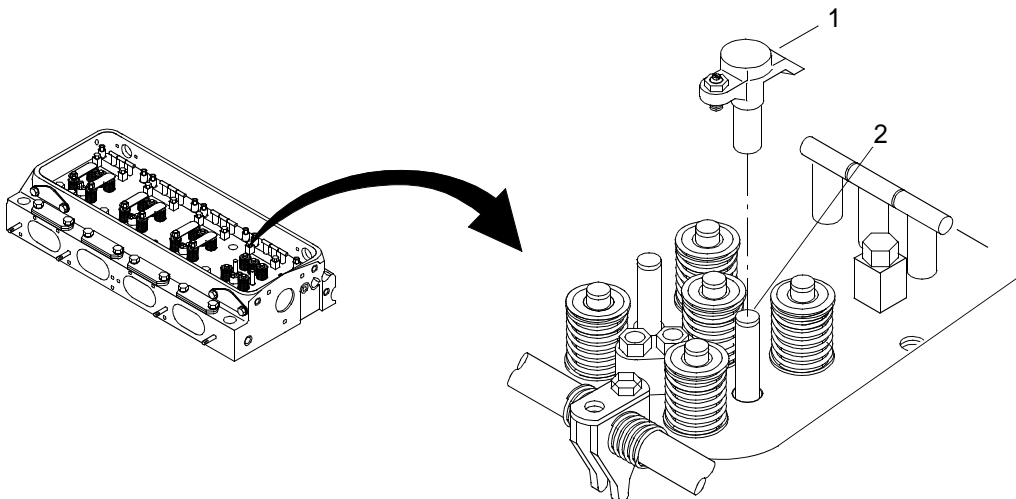

-
2. Discard cylinder head valve guide bridge (1).

INSTALL CYLINDER HEAD EXHAUST VALVE GUIDE BRIDGE

1. Install new set screw (3) and new hex nut (4) in new cylinder head exhaust valve guide bridge (1).

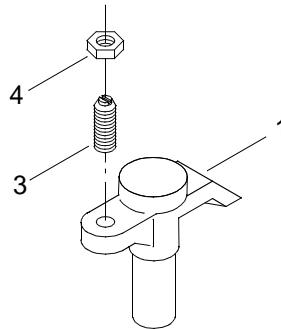

2. Install cylinder head exhaust valve guide bridge (1) on cylinder head valve guide (2).
3. Install cylinder head poppet valve rocker arms. (WP 0048 00)
4. Install fuel manifolds. (WP 0050 00)
5. Adjust cylinder head exhaust valves. (WP 0045 00)

END OF WORK PACKAGE

**GENERAL SUPPORT MAINTENANCE
CAUSEWAY FERRY
CYLINDER HEAD VALVE GUIDES AND SEALS
REPLACEMENT**

INITIAL SETUP:**Tools**

Tool Kit, General Mechanic's (Item 130, WP 0188 00)
 Press, Arbor, Hand Operated (Item 97, WP 0188 00)
 Remover, Valve Guide (Item 106, WP 0188 00)
 Gloves, Chemical (Item 52, WP 0188 00)
 Goggles, Industrial (Item 54, WP 0188 00)
 Installer, Valve Guide (Item 74, WP 0188 00)

Materials/Parts

Guide, Valve Stem
 (72582)
 NSN 2815-00-953-2460
 PN 5129919
 Qty 32

Seal, Valve Guide
 (72582)
 NSN 5330-00-992-0695
 PN 8921209
 Qty 32

Cloth, Cleaning (Item 13, WP 0187 00)
 Cleaner (Item 8, WP 0187 00)
 Lumber, Softwood, Dimension (2 in. X 4 in. X 6 ft Min Wooden Blocks) (Item 23, WP 0187 00)
 Qty 2
 Fuel, Diesel (Item 19, WP 0187 00)
 Oil, Lubricating, Engine, 40W (Item 27, WP 0187 00)

Personnel Required

Engineer 88L

REMOVE ENGINE VALVE GUIDE SEALS

WARNING

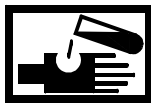
**CHEMICAL****EYE PROTECTION****NOTE**

The following procedure is typical for all 16 exhaust valve guides on both cylinder heads.

1. Remove cylinder head poppet valve rocker arm. (WP 0048 00)
2. Remove cylinder head exhaust valve bridges. (WP 0057 00)
3. Remove cylinder head exhaust valves. (WP 0054 00)

4. Remove and discard valve guide oil seal (1).

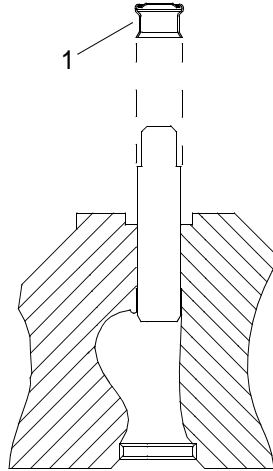

REMOVE ENGINE VALVE GUIDE

1. Remove fuel manifold. (WP 0050 00)
2. Remove fuel system injectors. (WP 0091 00)
3. Remove cylinder head cam followers. (WP 0052 00)
4. Place cylinder head (2), bottom side up, on two wooden blocks.

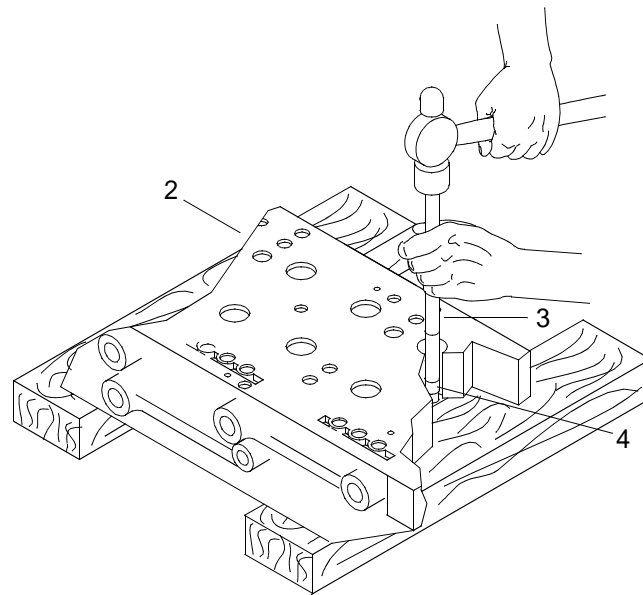

5. Using valve guide driver (3), drive valve guide (4) out of cylinder head (2).

INSTALL ENGINE VALVE GUIDES

1. Place cylinder head (2), right side up, on an arbor press.

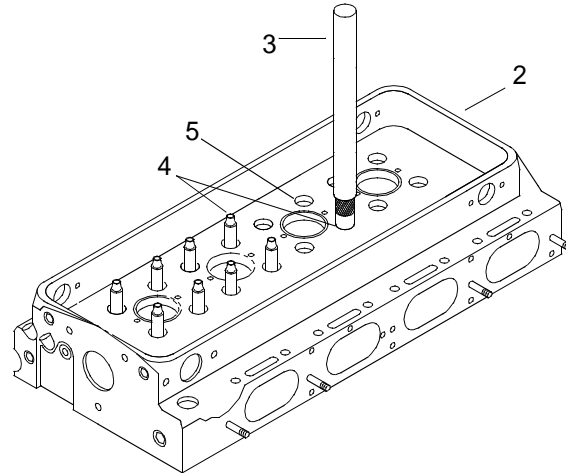

2. Insert internally threaded end of new valve guide (4) in valve guide installing tool (3).

CAUTION

Do not use valve guides or valve guide tool, when the tool is installed in cylinder head, to handle or turn over the cylinder head. Damage to valve guides and/or tool will occur.

3. Position valve guide (4) squarely in valve guide bore (5) and gently press valve guide installation tool (3) to start valve guide (4) in place.
4. Press valve guide (4) until valve guide installation tool (3) contacts cylinder head (2).
5. Remove valve guide installation tool (3).
6. Using a machinist's rule, verify height of valve guide (4) above cylinder head (2) is 0.670 - 0.710 in. (1.70 - 1.80 cm) above the cylinder head.
7. Remove cylinder head (2) from arbor press.
8. Install fuel system injectors. (WP 0091 00)
9. Install fuel manifold. (WP 0050 00)
10. Install cylinder head cam followers. (WP 0052 00)

INSTALL ENGINE VALVE GUIDE SEALS

1. Install the new valve guide oil seal (1) as follows.

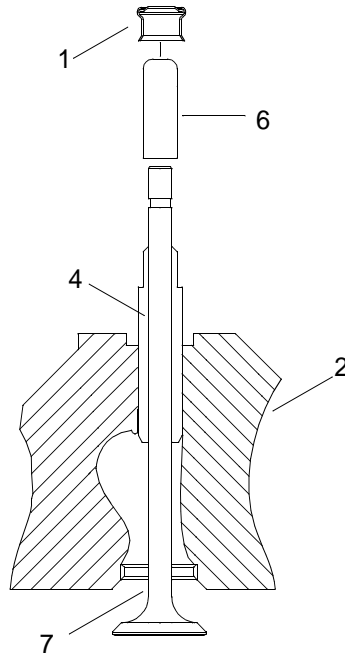

- a. Slide valve (7) into position in cylinder head (2).

NOTE

Installation caps come with the new valve guide seals and are disposed of when job is complete.

- b. Place a plastic seal installation cap (6) on end of valve (7).
- c. If installation cap (6) extends more than 1/16 in. below the groove on the valve stem (7), remove cap (6) and cut off excess length.

WARNING

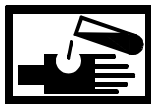

CHEMICAL



EYE PROTECTION

- d. Lubricate the installation cap with clean engine oil and start the seal (1) carefully onto the valve stem (5).

NOTE

The oil seal installation tool will position the oil seal so it does not bottom out on the valve guide. If the oil seal is installed too far and makes contact with the top of valve guide, it will distort and will not provide effective sealing.

- e. With the spring seat washer removed, use oil seal installation tool to push the valve guide oil seal (1) down until the tool bottoms on valve guide (4).

- f. Remove the installation cap (7).
2. Complete the installation of the exhaust valves. (WP 0054 00)
3. Install exhaust valve bridges. (WP 0057 00)
4. Install rocker arm and shaft. (WP 0048 00)

END OF WORK PACKAGE

**GENERAL SUPPORT MAINTENANCE
CAUSEWAY FERRY
CYLINDER HEAD EXHAUST VALVE GUIDES
CLEANING AND INSPECTION**

INITIAL SETUP:**Tools**

Tool Kit, General Mechanic's (Item 130, WP 0188 00)
 Brush, Cleaning, Valve Guide (Item 19, WP 0188 00)
 Brush, Wire Scratch (Item 21, WP 0188 00)
 Caliper Set, Micrometer, Outside (Item 22, WP 0188 00)
 Caliper Set, Micrometer, Inside (Item 23, WP 0188 00)
 Gloves, Chemical (Item 52, WP 0188 00)
 Goggles, Industrial (Item 54, WP 0188 00)
 Degreaser (tank, cleaning) (Item 32, WP 0188 00)

Materials/Parts

Cloth, Cleaning (Item 13, WP 0187 00)
 Fuel, Diesel (Item 19, WP 0187 00)
 Cleaner (Item 8, WP 0187 00)

Personnel Required

Engineer 88L

Equipment Condition

Fuel Manifold Removed (WP 0050 00)
 Cylinder Head Poppet Valve Rocker Arms Removed. (WP 0048 00)
 Cylinder Head Exhaust Valve Bridges Removed. (WP 0057 00)
 Fuel system Injectors Removed. (WP 0091 00)
 Cylinder Head Cam Followers Removed. (WP 0052 00)
 Cylinder Head Exhaust Valves Removed. (WP 0054 00)

CLEAN VALVE GUIDES AND VALVE STEMS

WARNING



CHEMICAL



EYE PROTECTION

NOTE

The following procedure is typical for all exhaust valve guides on both the starboard and port engines.

1. Place cylinder head (1) in a cleaning tank filled with cleaning solution

WARNING

**CHEMICAL****EYE PROTECTION**

- Using valve guide cleaning brush (2), clean the inside diameter of valve guides (3) to remove all gum and carbon deposits from the guides, including all spiral grooves.

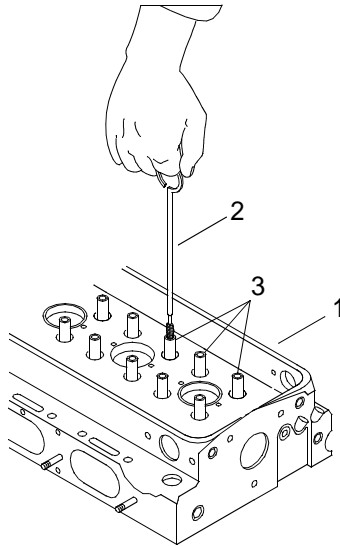

WARNING

**CHEMICAL****EYE PROTECTION**

- Using cleaner and a wire brush, clean carbon from the valve stems.

WARNING

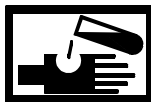
**CHEMICAL****EYE PROTECTION**

- Wash valve stems with diesel fuel and dry with cleaning cloth.

INSPECT VALVE GUIDES

1. Inspect valve guides (3) for fractures, chipping, scoring or wear. Replaced damaged parts.
2. Using an inside micrometer, measure the inside diameter of each valve guide at the top and record the readings.
3. Inspect valve stems for scratches and scuff marks. If stems are scratched or scuffed, replace valves. (WP 0054 00)
4. If original valves are being re-used, measure the outside diameter of the valve stems with an outside micrometer and record readings.
5. Compare the readings of the inside diameter of the guide with the outside diameter of the valve stem to obtain the valve-to-guide clearance.
6. If the clearance exceeds 0.005 in., replace the valves and valve guides. (WP 0058 00)
7. Install cylinder head exhaust valves. (WP 0054 00)
8. Install cylinder head cam followers. (WP 0052 00)
9. Install fuel system injectors. (WP 0091 00)
10. Install cylinder head exhaust valve bridges. (WP 0057 00)
11. Install cylinder head poppet valve rocker arms. (WP 0048 00)
12. Install fuel manifold. (WP 0050 00)

END OF WORK PACKAGE

**GENERAL SUPPORT MAINTENANCE
CAUSEWAY FERRY
CRANKSHAFT AND STABILIZER
REMOVAL, CLEANING, INSPECTION, REPAIR AND INSTALLATION**

INITIAL SETUP:**Tools**

Tool Kit, General Mechanic's
(Item 130, WP 0188 00)
Puller Kit, Universal J 24420-C
(Item 100, WP 0188 00)
Hammer, Hand, (Dead Blow)
(Item 59, WP 0188 00)
Wrench, Torque (0-175 ft lbs)
(Item 138, WP 0188 00)
Wrench, Torque (0-75 in. lbs)
(Item 140, WP 0188 00)
Wrench, Torque (100-600 ft lbs)
(Item 139, WP 0188 00)
Wrench Set, Socket (¾ in. sqdr.)
(Item 134, WP 0188 00)
Screwdriver Attachment Set, Socket Wrench
(Item 112, WP 0188 00)
Shackle, ¾ in., 4.75 ton (Item 116, WP 0188 00)
Qty 3
Sling 5300 lbs 6 ft (Green) (Item 118, WP 0188 00)
Qty 4
Gloves, Chemical (Item 52, WP 0188 00)
Goggles, Industrial (Item 54, WP 0188 00)
Hoist, Chain (Item 65, WP 0188 00)
Gage, Strain (Item 50, WP 0188 00)
Brush, Wire Scratch (Item 21, WP 0188 00)
Indicator, Dial (Item 67, WP 0188 00)

Materials/Parts

Plug, Pipe
(73342)
PN 444687
Grease, Ball and Roller Bearing
(Item 21, WP 0187 00)
Cleaning Compound (Item 10, WP 0187 00)
Oil, Lubricating, Engine, 30W
(Item 26, WP 0187 00)
Rags, Wiping (Item 28, WP 0187 00)

Personnel Required

Engineer 88L

Equipment Condition

Crankcase Breather Limiter Assembly Removed.
(WP 0106 00)

Equipment Condition (Cont'd)

Air Inlet Collector Assembly Removed.
(WP 0104 00)
Turbocharger Removed. (WP 0114 00)
Exhaust Manifold Removed. (WP 0163 00)
Marine Gear Oil Cooler Removed.
(TM 55-1945-205-24-1-3)
Fuel Cooler Removed. (WP 0081 00)
Air Box Covers Removed. (WP 0035 00)
Air Box Drains Removed. (WP 0036 00)
Starting Motor Removed. (WP 0170 00)
Lube Oil Dipstick Tube Assembly Removed.
(WP 0130 00)
Overspeed Governor Removed. (WP 0175 00)
Marine Gear Oil Cooler Mounting Bracket
Removed. (WP 0164 00)
Lube Oil Cooler Removed. (WP 0128 00)
Engine Mounted On Stand. (WP 0032 00)
Fresh Water Cooling System Bypass Hoses
Removed. (WP 0148 00)
Cylinder Head Poppet Valve Rocker Arm Covers
Removed. (WP 0043 00)
Electronic Governor Actuator Rod Removed.
(WP 0097 00)
Governor Actuator Removed. (WP 0098 00)
Fuel Pump Removed. (WP 0094 00)
Air Intake Housing Removed. (WP 0103 00)
Blower Drive Shaft Removed. (WP 0109 00)
Blower Removed. (WP 0110 00)
Heat Exchanger Removed. (WP 0138 00)
Fresh Water Cooling System Starboard Thermostat
Housing Removed. (WP 0144 00)
Fresh Water Cooling System Port Thermostat
Housing Removed. (WP 0145 00)
Fuel Injector Control Tube and Lever Removed.
(WP 0086 00)
Flywheel Housing removed. (WP 0071 00)
Vibration Dampener Removed. (WP 0074 00)
Cylinder Heads Removed. (WP 0046 00)
Lube Oil Pan Removed. (WP 0127 00)
Lube Oil Pressure Regulator Valve Removed.
(WP 0123 00)
Lube Oil Pressure Relief Valve Removed.
(WP 0125 00)

REMOVE CRANKSHAFT

NOTE

Note the location of each rod and main bearing cap to ensure that they are installed in the same location. If the bearings are to be reused they also must be returned to the same location.

1. Remove hex bolts with washer (1) from stabilizers (2).

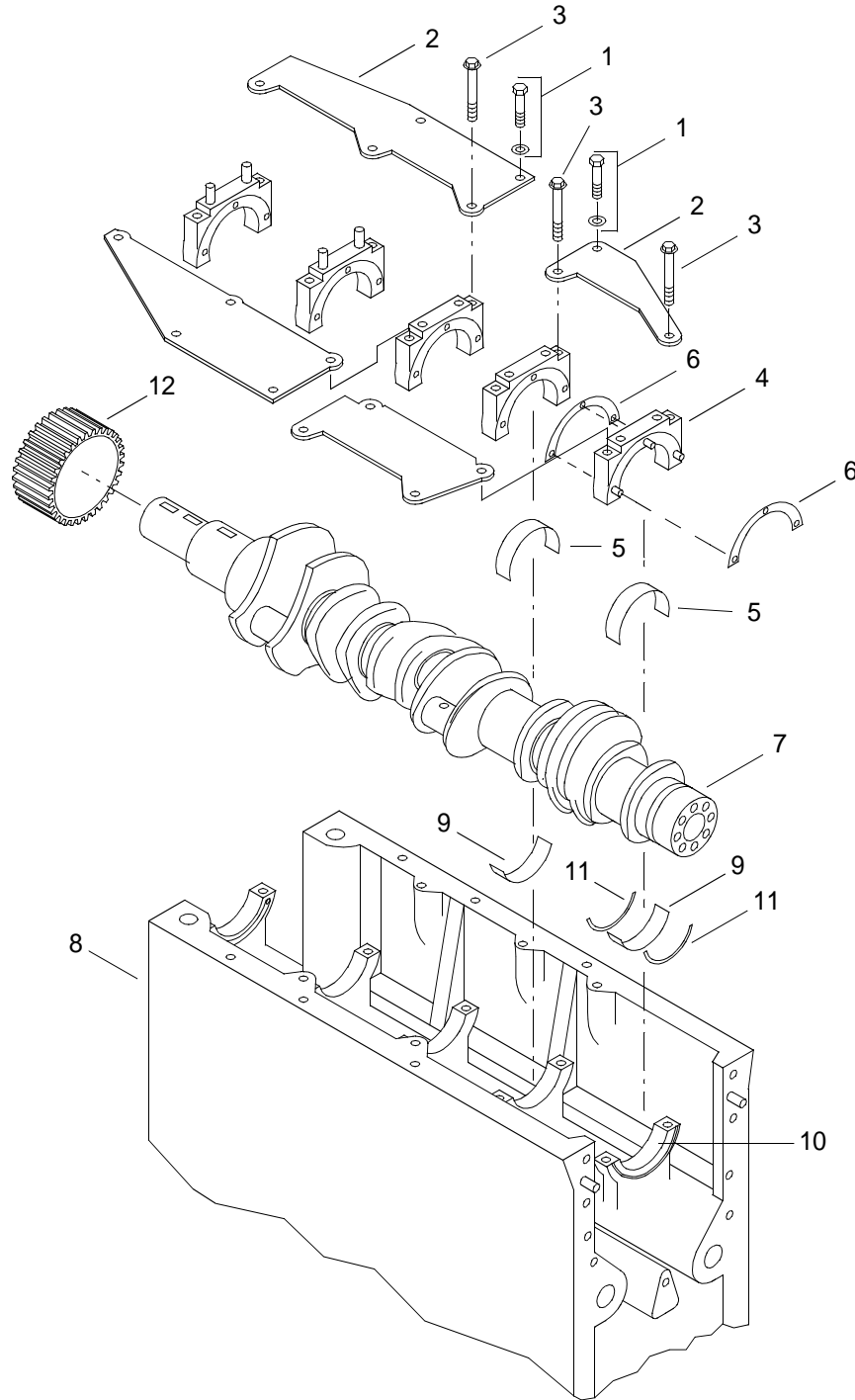

2. Remove hex head bolts (3) from main bearing caps (4).

3. Remove stabilizers (2) and main bearing caps (4).
4. Tag main bearings caps (4) and main bearings (5).
5. Remove lower bearings (5) from main bearings caps (4).
6. Remove two lower thrust washer halves (6) from each side of the rear main bearing cap (4).

WARNING



HEAVY OBJECTS

7. Using an overhead hoist and a suitable nylon sling, carefully lift crankshaft assembly (7) from the engine block (8).
8. Tag and remove upper bearings (9) from upper bearing surface (10).
9. Remove two upper thrust washer halves (11) from each side of the upper bearing surface (10).
10. Remove the oil pump drive gear (12) from the crankshaft (7).

CLEAN CRANKSHAFT

WARNING

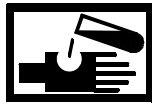

CHEMICAL

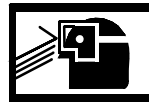

EYE PROTECTION

1. Soak crankshaft (7) in cleaning compound to remove dirt and oil.

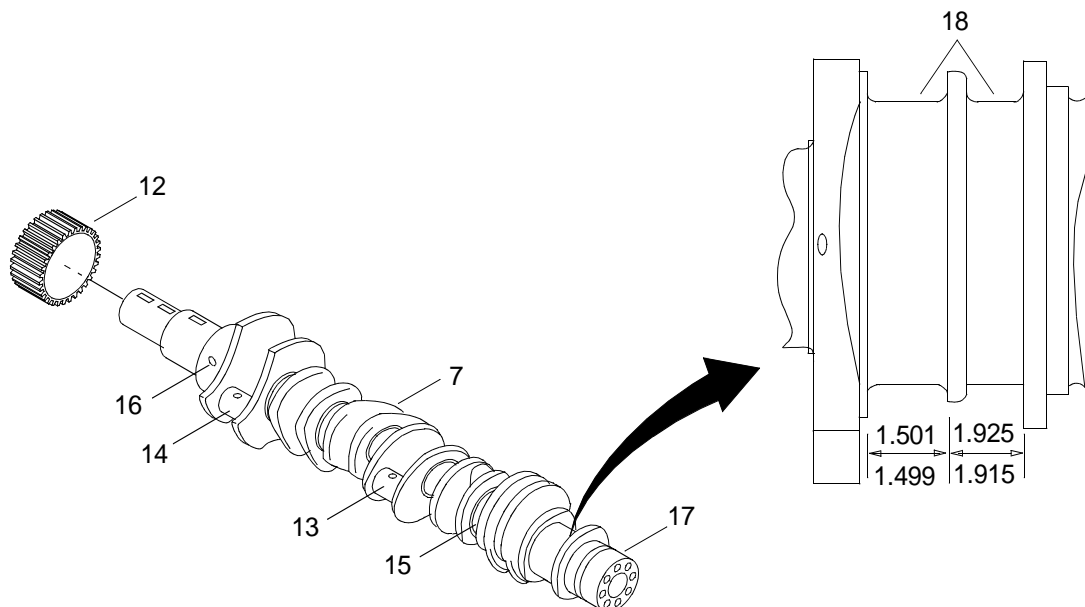

WARNING

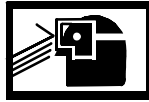
**EYE PROTECTION**

2. Use a small stiff wire brush to clean oil passages (13).
3. Wipe excess dirt and grease from crankshaft (7) using a wiping rag.

WARNING

**CHEMICAL****EYE PROTECTION**

4. Dispose of oily rags in accordance with local procedures

WARNING

**EYE PROTECTION**

**Do not exceed 40 PSI (275 kPa) when using compressed air for drying components.
Failure to comply could result in serious injury to personnel.**

5. Dry crankshaft (7) using compressed air.

INSPECT CRANKSHAFT

1. Check crankshaft (7), journal surfaces (14 and 15) and oil passages (16) for cracks using magnetic particle inspection or equivalent. Replace crankshaft if damage is found.
2. Check crankshaft (7) for discoloration, excessive wear and pitting. Replace crankshaft if wear or pitting is found.
3. Check all journal surfaces (14 and 15) for scoring and discoloration. Replace crankshaft if scoring or discoloration is found.
4. Check oil seal contact surface (17) for scoring, grooving or excessive wear.

NOTE

If scoring, grooving or excessive wear exists, this may cause leakage. The seal contact surface may be sleeved and an oversize seal may be installed.

Measurements of the crankshaft should be accurate to the nearest 0.0002 in. (0.00051 cm).

5. Measure crankshaft thrust washer surfaces (18) for excessive wear or grooving. Replace crankshaft if out of tolerance.
6. Measure the crankshaft (7) bow.

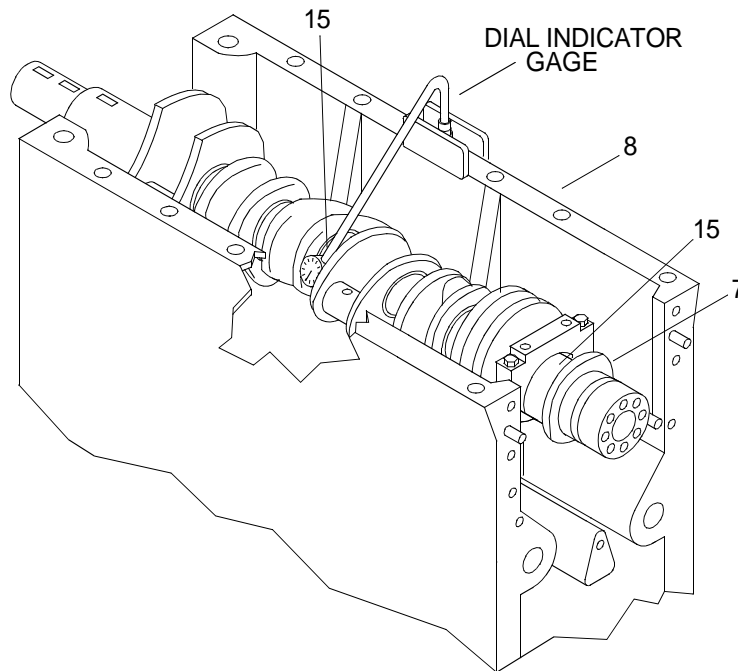

- a. Support the crankshaft (7) on the first (one) and last (fifth) main bearing journals (15) in an inverted engine block (8) with all but the front and rear bearings removed.
- b. Attach dial indicator to engine block (8) at the third main bearing journal (15).
- c. Rotate crankshaft (7) by hand. Observe dial indicator for run out indication. Run out limit shall not exceed 0.004 in. If run out exceeds limits replace crankshaft.
- d. Repeat steps b and c for journals two and four. Run out limit shall not exceed 0.002 in. If run out exceeds limits replace crankshaft.

- e. Measure connecting rod bearing journals (14) and main bearing journals (15) in several places on the circumference to determine taper out, out-of-round and bearing clearances.

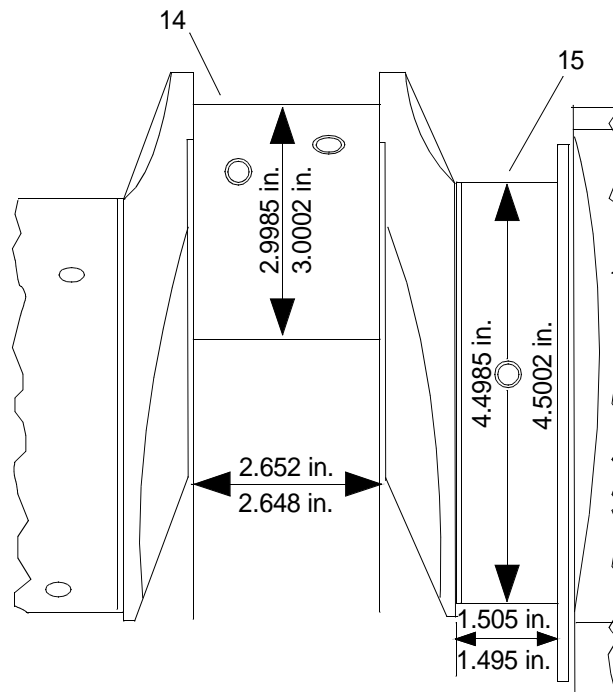

NOTE

Ensure that all crankshaft measurements are accurate within ± 0.0002 in. (0.00051 cm).

- {1} Connecting rod journal (14) diameter should be 2.9985 – 3.0002 in. (7.616 – 7.621 cm). Replace crankshaft if out of tolerance.
- {2} Connecting rod journal (14) width should be 2.652 – 2.648 in. (6.726 – 6.736 cm). Replace crankshaft if out of tolerance.
- {3} Main bearing journal (15) diameter should be 4.4985 – 4.5002 in. (11.426 – 11.431 cm). Replace crankshaft if out of tolerance.
- {4} Main bearing journal (15) width should be 1.495 – 1.505 in (3.797 – 3.823 cm). Replace crankshaft if out of tolerance.
- {5} Crank shaft (7) maximum connecting rod journal (14) or main bearing journal (15) to bearing clearance, with new bearings, should not exceed 0.0045 (0.01143 cm) on the connecting rod bearings, ± 0.0002 in. (0.0051 cm) and 0.0055 in. (0.01397 cm) on the main bearings, ± 0.0015 in. (0.00381 cm). Replace crankshaft if out of tolerance.
- {6} Main bearing journal (15) taper should not exceed 0.0004 in. (0.01143 cm). Replace crankshaft if out of tolerance.
- {7} Main bearing (5) out-of-round should not exceed 0.0005 in. (0.00127 cm). Replace crankshaft if out of tolerance.
- {8} Measure the new bearing thickness, it should be 0.1548 in. (0.3932 cm) ± 0.0003 in. (0.000762 cm).

{9} Measure the old bearing thickness, it should be a minimum of 0.1540 in. (0.3912 cm).

7. Inspect the crankshaft stabilizers (2) for cracks, discoloration, out of shape or excessive wear, replace as necessary.
8. Inspect woodruff keys (19) for damage. Replace if necessary.
9. Inspect plugs (20) for damage. Replace if necessary.

REPAIR CRANKSHAFT

1. Remove woodruff keys (19) from crankshaft (7).

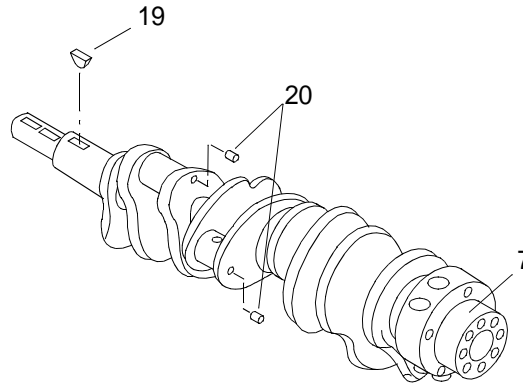

2. Install new woodruff keys (19) into crankshaft (7).
3. Remove plugs (20) from the crankshaft (7).
4. Install new plugs (20) into the crankshaft (7).
5. Using a torque wrench and screwdriver attachment, torque plug (20) to 120–144in-lbs (13.5–16.3 N-m).

INSTALL CRANKSHAFT

1. Slide oil pump drive gear (12) onto crankshaft (7).

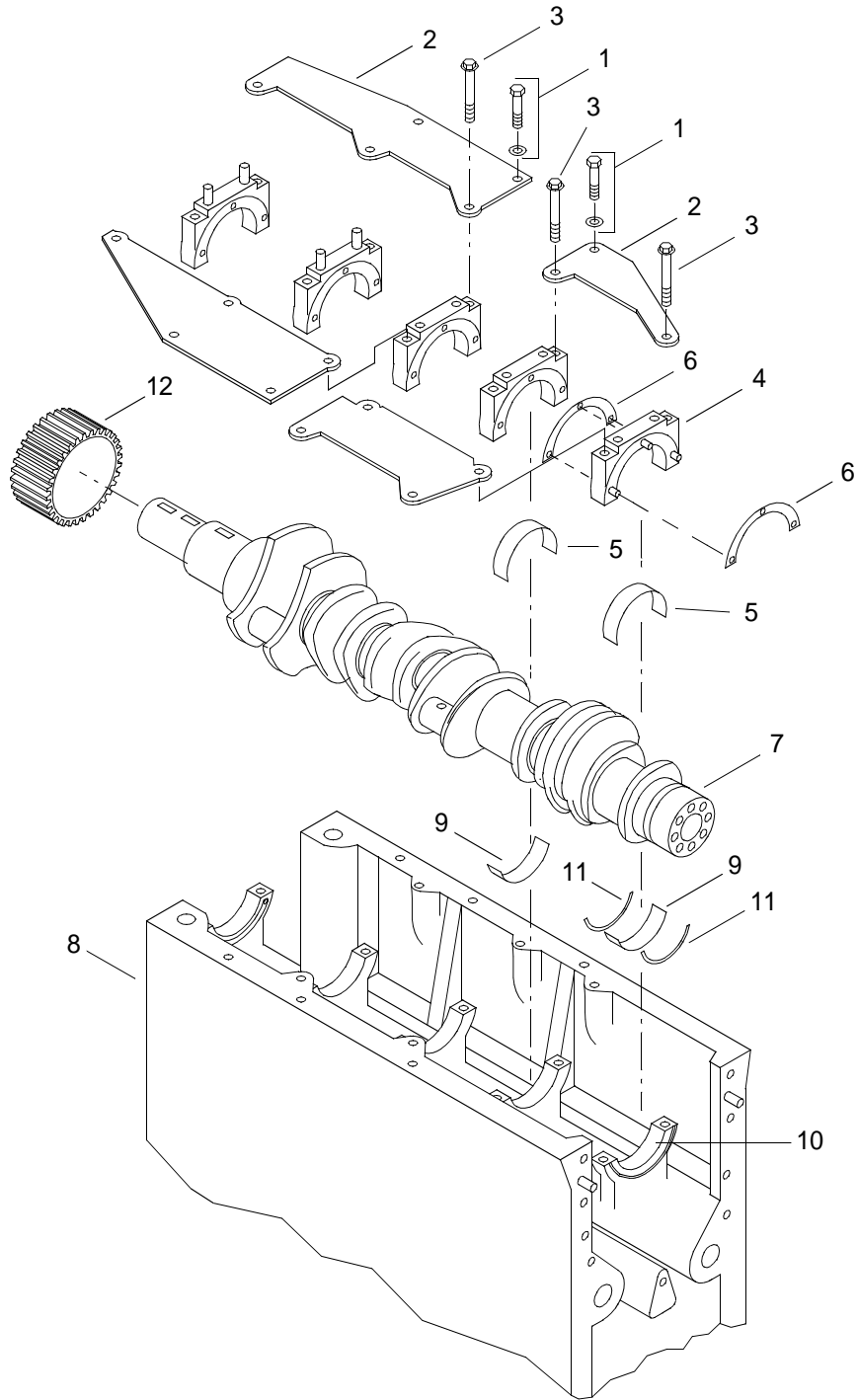

CAUTION

The upper and lower bearings are different. The upper bearing (engine block side) has a slot or groove for oil distribution. The lower bearing (main cap side) is plain with no slot. Ensure bearings are installed in correctly. Failure to comply will result in serious damage to engine.

2. Install the main bearings and caps.
 - a. Install upper bearings (9) in main bearing surface (10) with the tangs on the bearings aligned with the slots in the engine block.

WARNING



CHEMICAL

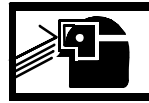

EYE PROTECTION

- b. Apply a light coat of engine oil to the crankshaft upper bearing surfaces (9).
- c. Install the crankshaft (7) into the engine block (8) and the upper bearings (9).

CAUTION

The grooved side of the thrust washers must face toward the crankshaft surface. Failure to comply will result in damage to engine.

- d. Install the upper halves of the thrust washers (11) on each side of the rear upper bearing (9).
- e. Install the lower bearings (5) in the main bearing caps (4) with the tangs on the bearings aligning with the slots on the main bearing caps (4).
- f. Install the lower thrust washers (6) on both sides of the rear main bearing cap (4).
- g. Install the lower main bearing caps (4) in their original locations.

NOTE

There are two types of main bearing bolts. One has a fixed washer surface as a part of the head of the bolt. The other has a separate hardened washer.

- h. Install bolts (3).

WARNING



CHEMICAL



EYE PROTECTION

- { 1 } On bolts (3) with fixed washer, coat the threads and the bolt head contact surfaces with a light weight grease.

WARNING

**CHEMICAL****EYE PROTECTION**

- {2} On bolts (3) with harden washer, coat the threads and both sides of the hardened washer with a light weight grease.
- i. Install bearing cap stabilizers (2) on bearing caps (4).
- j. Install bolts with washer (1) on bearing cap stabilizers (2).
- k. Tighten all bolts (1 and 3) until snug.
- l. Tap the bearing caps (4) sharply with a dead blow hammer to seat them properly.
- m. Torque all main bearing cap bolts (4) except rear main.
 - {1} Using a torque wrench, torque bolts (4) with fixed washer to 250-260 ft lbs (339-353 N-m).
 - {2} Using a torque wrench, torque bolts (4) with harden washer to 230-240 ft lbs (312-325 N-m).
- n. Torque rear main bolts (4).
 - {1} Using a torque wrench, torque rear main bolts (4) to 480-600 in-lbs (54-68 N-m).
 - {2} Tap both ends of the crankshaft (7) sharply with a dead blow hammer two or three times to properly position the rear main cap (4) on the main bearing journal (12).
 - {3} Using a torque wrench, torque bolts (4) with fixed washer to 250-260 ft lbs (339-353 N-m).
 - {4} Using a torque wrench, torque bolts (4) with harden washer to 230-240 ft lbs (312-325 N-m).
- o. Using a torque wrench, torque all bearing stabilizer bolts (1) to 70-75 ft lbs (95-102 N-m).
- p. Turn crankshaft (7) to verify free and smooth rotation.

3. Check the crankshaft (7) end play.

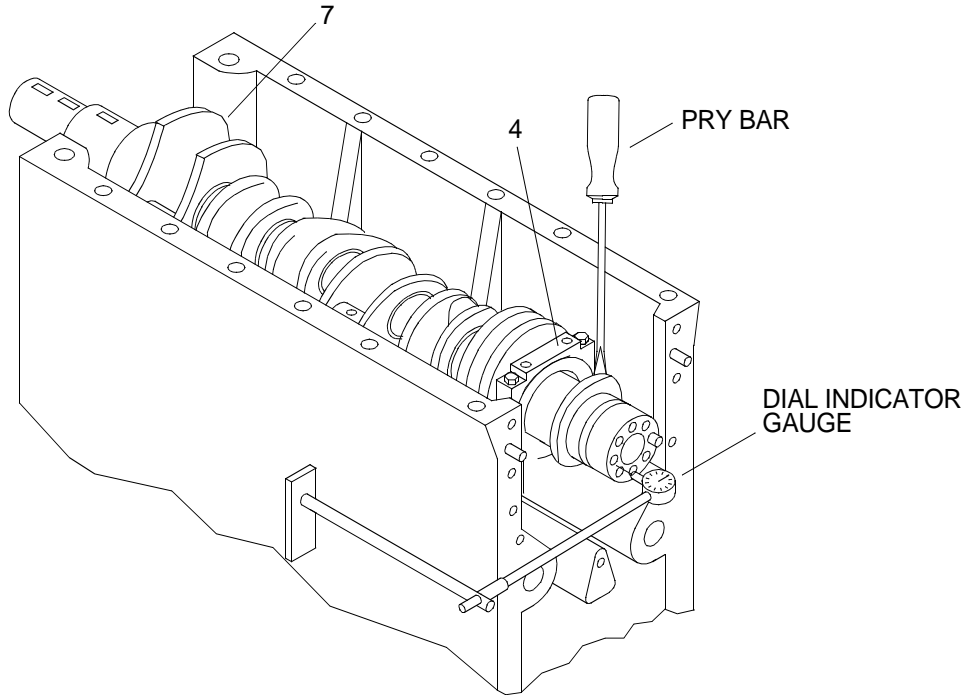

- a. Attach the dial indicator guide rod to the block.
- b. Attach the dial indicator to the guide rod so that it is positioned on the end of the crankshaft (7).
- c. Using a small 12 in. pry bar, apply constant pressure on the crankshaft (7) toward the gauge and set the dial indicator to zero.
- d. Place the pry bar on the other side of the bearing cap (4) and pry the crankshaft (7) in the opposite direction.
- e. Read the dial indicator.

NOTE

With new parts the end play should be 0.004 to 0.011 in. (0.01016–0.02794 cm).

With old parts the end play should not be more than 0.018 in. (0.04572 cm).

- f. If the end play is insufficient, proceed as follows.
 - {1} Check for misaligned rear main bearing (5 and 9).
 - {2} Check for dirt between the crankshaft (7), thrust washers (6 and 11) and the engine block (8).
 - {3} Check for burrs between the crankshaft (7), thrust washers (6 and 11) and the engine block (8).
 - {4} Replace thrust washers (6 and 11).
 - g. If the end play is too great an oversize thrust washer will be required.
4. Install lube oil pressure relief valve.(WP 0125 00)

5. Install lube oil pressure regulator valve. (WP 0123 00)
6. Install lube oil pan. (WP 0127 00)
7. Install cylinder heads. (WP 0046 00)
8. Install fuel injector control tube and lever. (WP 0086 00)
9. Install blower. (WP 0110 00)
10. Install blower drive shaft. (WP 0109 00)
11. Install governor actuator. (WP 0098 00)
12. Install electronic governor actuator rod. (WP 0097 00)
13. Install cylinder head poppet valve rocker arm covers. (WP 0043 00)
14. Install water pump bypass tube. (WP 0148 00)
15. Install fuel pump. (WP 0094 00)
16. Install air intake housing. (WP 0103 00)
17. Install port thermostat housing. (WP 0145 00)
18. Install starboard thermostat housing. (WP 0144 00)
19. Install heat exchanger. (WP 0138 00)
20. Remove engine from the stand. (WP 0032 00)
21. Install lube oil cooler. (WP 0128 00)
22. Install marine gear oil cooler mounting bracket. (WP 0164 00)
23. Install overspeed governor. (WP 0175 00)
24. Install lube oil dipstick tube. (WP 0130 00)
25. Install starter motor. (WP 0170 00)
26. Install air box drains. (WP 0036 00)
27. Install air box covers. (WP 0035 00)
28. Install fuel cooler. (WP 0081 00)
29. Install marine gear oil cooler. (TM 55-1945-205-24-3-3)
30. Install exhaust manifold. (WP 0163 00)
31. Install turbocharger. (WP 0114 00)
32. Install air inlet collector assembly. (WP 0104 00)

33. Install crankcase breather limiter assembly. (WP 0106 00)
34. Install vibration dampener. (WP 0074 00)
35. Install flywheel housing. (WP 0071 00)
36. Check the crankshaft (7) distortion.
 - a. Rotate the crankshaft (7) clockwise until the counter weights (21) at the rear connecting rod journal are rotated to the bottom of the engine (six o'clock position).

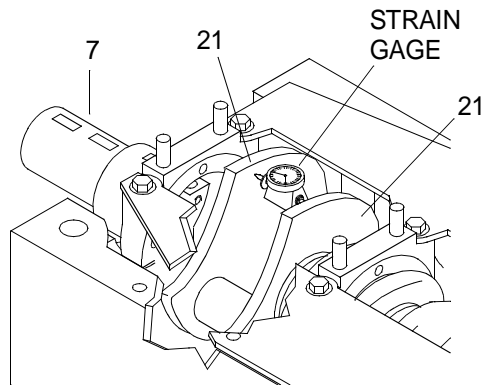

- b. Center punch a dimple on the inside face of each counter weight (21), $\frac{1}{4}$ of an inch in and centered.
- c. Install strain gauge in dimples made in step b. above.
- d. Set the dial indicator to zero and rotate the crankshaft approximately 90° in each direction.
- e. Remove tool used to rotate the engine.

NOTE

The maximum allowable variation is 0.0045 in. total indicator reading.

If the reading is greater than 0.0045 in., check the reduction gear or the marine gear for proper alignment.

37. Install the marine gear. (TM 55-1945-205-24-1-3)
38. Recheck crankshaft (7) distortion.

END OF WORK PACKAGE

**GENERAL SUPPORT MAINTENANCE
CAUSEWAY FERRY
CRANKSHAFT REAR OIL SEAL
REPLACEMENT**

INITIAL SETUP:**Tools**

Tool Kit, General Mechanic's (Item 130, WP 0188 00)
Handle, Driver (Item 62, WP 0188 00)
Seal Installer, FLYW (Item 113, WP 0188 00)
Gloves, Chemical (Item 52, WP 0188 00)
Goggles, Industrial (Item 54, WP 0188 00)
Pin, Drift (Item 90 WP 0188 00)

Materials/Parts

Seal, Oil
(72582)
PN 8929750
Oil, Lubricating, Engine, 30W (Item 26, WP 0187 00)
Lumber, Softwood, Dimension (2 in. X 4 in. X 6 ft Min Wooden Blocks) (Item 23, WP 0187 00)
Qty 2

Personnel Required

Engineer 88L

Equipment Condition

Crankcase Breather Limiter Removed. (WP 0106 00)
Air Inlet Collector Assembly Removed. (WP 0104 00)
Turbochargers Removed. (WP 0114 00)
Exhaust Manifolds Removed. (WP 0163 00)
Marine Gear Oil Cooler Removed. (TM 55-1945-205-24-1-3)
Fuel Cooler Removed. (WP 0081 00)
Air Box Covers Removed. (WP 0035 00)
Air Box Drains Removed. (WP 0036 00)
Starting Motor Removed.(WP 0170 00)
Lube Oil Dipstick Tube Assembly Removed. (WP 0130 00)
Overspeed Governor Removed. (WP 0175 00)
Marine Gear Oil Cooler Mounting Bracket Removed. (WP 0164 00)
Lube Oil Cooler Removed. (WP 0128 00)
Engine Installed On Stand. (WP 0032 00)
Electrical System Hour Meter Removed. (WP 0167 00)
Electrical System Hour Meter Mounting Bracket Removed. (WP 0168 00)
Raw Water Pump Removed. (WP 0160 00)
Lube Electronic Governor Magnetic Pick-Up Removed. (WP 0100 00)
Oil Pan Removed. (WP 0127 00)
Flywheel Removed. (WP 0069 00)
Flywheel Housing Removed. (WP 0071 00)

REMOVE CRANKSHAFT REAR OIL SEAL

1. Lay flywheel housing (1) engine side down on wooden blocks on a workbench.

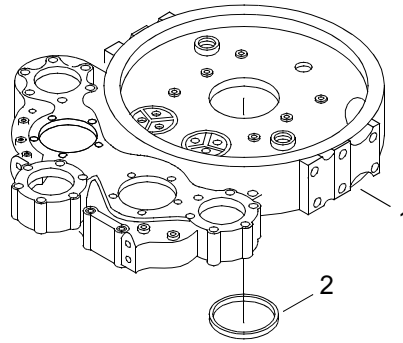

WARNING

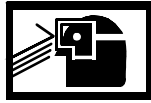

EYE PROTECTION

- Using a brass drift and a ball peen hammer, remove the rear crankshaft oil seal (2) from the flywheel housing (1).

INSTALL CRANKSHAFT REAR OIL SEAL

WARNING



CHEMICAL

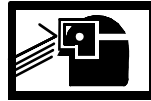

EYE PROTECTION

- Lubricate the outside edge of new oil seal (2) with engine lubricating oil.

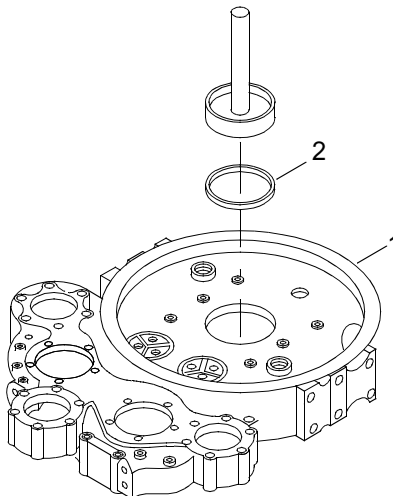

- Using seal installer J 21112-B, driver handle J-3154-1A and a ball peen hammer, install seal (2) into flywheel housing (1).
- Install flywheel housing. (WP 0071 00)

-
4. Install flywheel. (WP 0069 00)
 5. Install oil pan. (WP 0127 00)
 6. Install electronic governor magnetic pick-up. (WP 0100 00)
 7. Install raw water pump. (WP 0160 00)
 8. Install electrical system hour meter mounting bracket. (WP 0168 00)
 9. Install electrical system hour meter. (WP 0167 00)
 10. Remove engine from stand. (WP 0032 00)
 11. Install lube oil cooler. (WP 0128 00)
 12. Install marine gear oil cooler mounting. (WP 0164 00)
 13. Install overspeed governor. (WP 0175 00)
 14. Install lube oil dipstick tube assembly. (WP 0130 00)
 15. Install starting motor.(WP 0170 00)
 16. Install air box drains. (WP 0036 00)
 17. Install air box covers. (WP 0035 00)
 18. Install fuel cooler. (WP 0081 00)
 19. Install marine gear oil cooler. (TM 55-1945-205-24-1-3)
 20. Install exhaust manifolds. (WP 0163 00)
 21. Install turbochargers. (WP 0114 00)
 22. Install air inlet collector assembly. (WP 0104 00)
 23. Install crankcase breather limiter assembly. (WP 0106 00)

END OF WORK PACKAGE

**GENERAL SUPPORT MAINTENANCE
CAUSEWAY FERRY
CAMSHAFT AND BEARINGS
REPLACEMENT**

INITIAL SETUP:**Tools**

Tool Kit, General Mechanic's (Item 130, WP 0188 00)
Body, Puller, (Item 11, WP 0188 00)
Adaptor, Mechanical Puller (Item 3, WP 0188 00)
Indicator, Dial (Item 67, WP 0188 00)
Puller Kit, Universal (Slide Hammer) (Item 100, WP 0188 00)
Press, Arbor, Hand Operated (Item 97, WP 0188 00)
Wrench Set, Socket (3/8 in. sqdr.) (Item 135, WP 0188 00)
Wrench, Torque (150-750 in. lbs) (Item 142, WP 0188 00)
Wrench, Torque (100-600 ft lbs) (Item 139, WP 0188 00)
Wrench Set, Socket (3/4 in. sqdr.) (Item 134, WP 0188 00)
Apron, Utility (Item 8, WP 0188 00)
Gloves, Chemical (Item 52, WP 0188 00)
Goggles, Industrial (Item 54, WP 0188 00)

Materials/Parts

Bearing, Washer
(72582)
NSN 3120-00-585-3282
PN 5111424
Cleaner (Item 8, WP 0187 00)
Oil, Lubricating, Engine, 10W (Item 25, WP 0187 00)
Grease, Ball and Roller Bearing (Item 21, WP 0187 00)
Cloth, Cleaning (Item 13, WP 0187 00)

Personnel Required

Engineer 88L

Equipment Condition

Crankcase Breather Limiter Assembly Removed. (WP 0106 00)
Air Inlet Collector Assembly Removed. (WP 0104 00)
Turbochargers Removed. (WP 0114 00)
Exhaust Manifolds Removed. (WP 0163 00)
Marine Gear Oil Cooler Removed. (TM 55-1945-205-24-1-3)
Fuel Cooler Removed. (WP 0081 00)
Air Box Covers Removed. (WP 0035 00)
Air Box Drains Removed. (WP 0036 00)
Starter Motor Removed. (WP 0170 00)
Lube Oil Dipstick Tube Assembly Removed. (WP 0130 00)
Overspeed Governor Removed. (WP 0175 00)
Marine Gear Oil Cooler Mounting Bracket Removed. (WP 0164 00)
Lube Oil Cooler Removed. (WP 0128 00)
Engine Installed On Stand. (WP 0032 00)
Fresh Water Cooling System By-pass Hoses Removed. (WP 0148 00)
Fresh Water Cooling System Port Thermostat Housing Removed. (WP 0145 00)
Fresh Water Cooling System Starboard Thermostat Housing Removed. (WP 0144 00)
Fresh Water Cooling System Port Water Outlet Manifold Removed. (WP 0150 00)
Fresh Water Cooling System Starboard Water Outlet Manifold Removed. (WP 0151 00)

Equipment Condition (Cont'd)

Cylinder Head Poppet Valve Rocker Arm Cover Removed. (WP 0043 00)
 Cylinder Head Poppet Valve Rocker Arms Removed. (WP 0048 00)
 Fuel Injector Control Removed. (WP 0086 00)
 Cylinder Heads Removed. (WP 0046 00)
 Electrical System Hour Meter Removed. (WP 0167 00)
 Electrical System Hour Meter Mounting Bracket Removed. (WP 0168 00)
 Raw Water Pump Removed. (WP 0160 00)
 Electronic Governor Magnetic Pick-Up Removed. (WP 0100 00)
 Oil Pan Removed. (WP 0127 00)
 Flywheel Removed. (WP 0069 00)
 Flywheel Housing Removed. (WP 0071 00)
 Fresh Water Cooling System Filter Element Removed. (WP 0140 00)
 Fresh Water Cooling System Drained. (WP 0133 00)
 Heat Exchanger Removed. (WP 0138 00)
 Main Fuel Filter Removed. (WP 0079 00)
 Fresh Water Cooling System Pump Removed. (WP 0152 00)
 Forward Lifting Bracket Removed. (WP 0139 00)
 Camshaft Accessory Drive Pulley Removed. (WP 0066 00)
 Front Balance Weight Cover Removed. (WP 0076 00)
 Fresh Water Cooling System Pump Drive Gear Removed. (WP 0153 00)

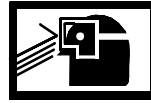
REMOVE CAMSHAFTS**WARNING****HEAVY PARTS****EYE PROTECTION**

1. On the rear of the engine, remove four screws (1), adaptor (2) and retainer (3) from left camshaft gear (4).

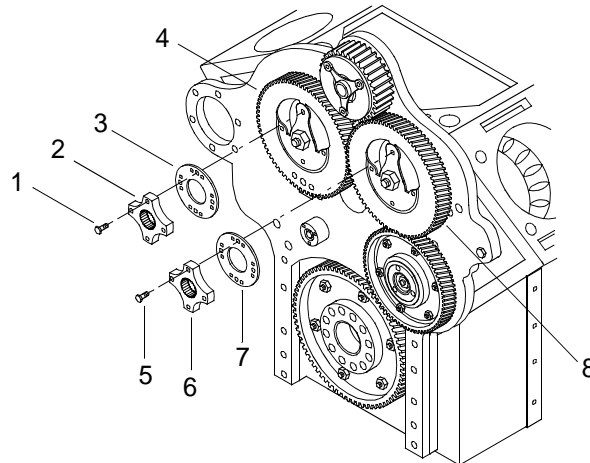

2. Remove four screws (5), adaptor (6) and retainer (7) from right camshaft gear (8).

3. Place a clean rag between gears (4 and 8).

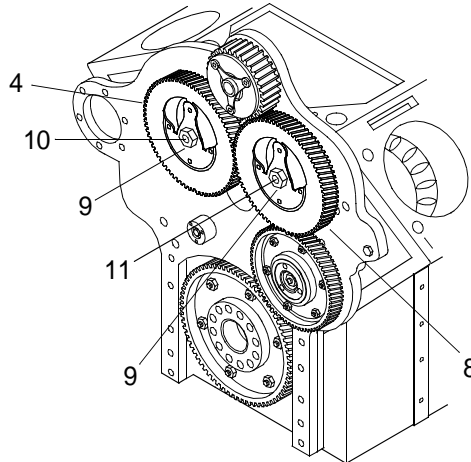

4. Loosen two nuts (9) from rear end of camshaft (10 and 11), but do not remove.
5. On the front of engine, remove nut (12) and lock washer (13), from accessory drive pulley (14) on front of camshaft (10).

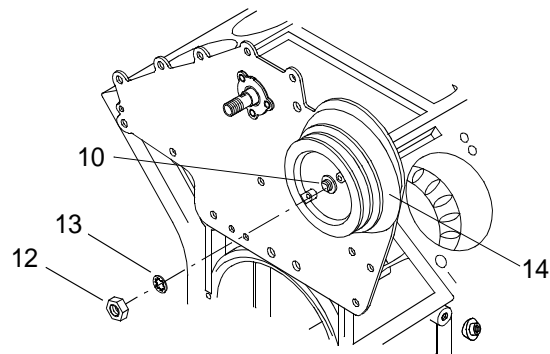

6. Using puller J 24420, remove accessory drive pulley (14) from camshaft (10).

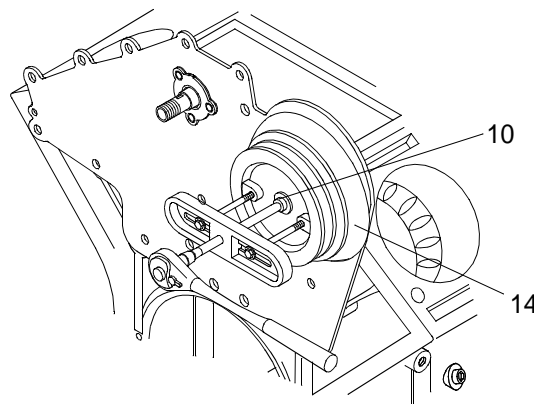

7. Remove woodruff key (15) and spacer (16) from front end of camshaft (10 and 11).

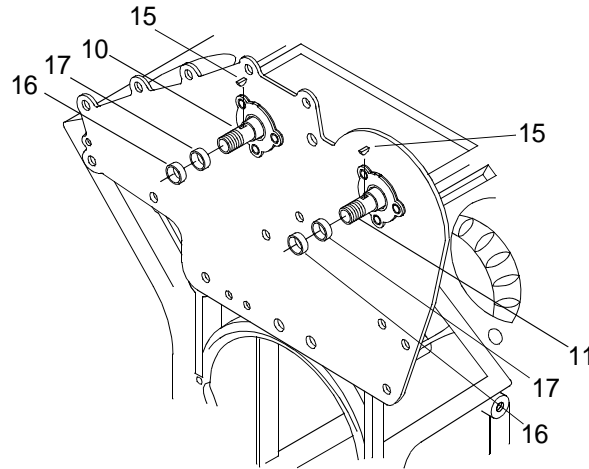

8. Remove oil seal (17) from camshaft (10 and 11).
9. Remove six intermediate bearing lock screws (18) from camshafts (10 and 11).

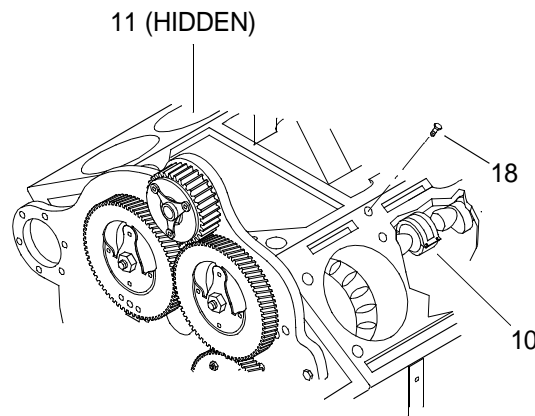

10. Remove rag between gears (4 and 8).

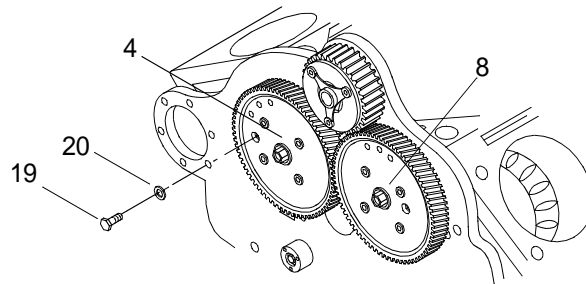

11. Rotate the camshaft gears (4 and 8) exposing camshaft bearing cap screws (19) and washers (20) one at a time. Remove all six sets.

CAUTION

During the removal of the camshafts, avoid scraping or hitting engine block or any other hard surface. Failure to comply may cause damage to camshafts.

12. Remove camshafts (10 and 11) from engine block (21).

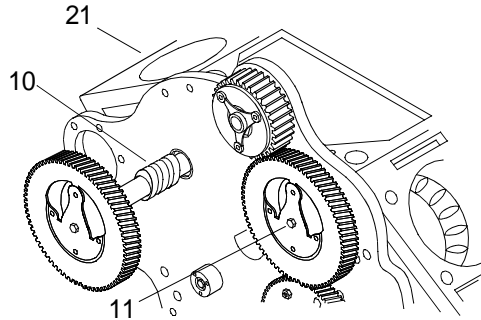

13. On the front of engine, remove six cap screws (22) and lock washers (23) from each front cam bearing (24).

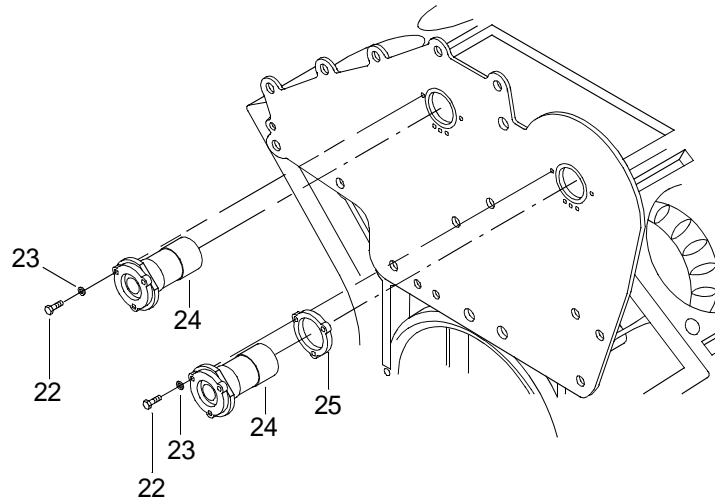

NOTE

Only the left cam bearing has a gasket.

14. Remove two bearings (24) and gasket (25).

DISASSEMBLE CAMSHAFTS

NOTE

This procedure is typical for both camshafts.

1. Remove nut (9) securing gears (4 and 8) to camshafts (10 and 11).

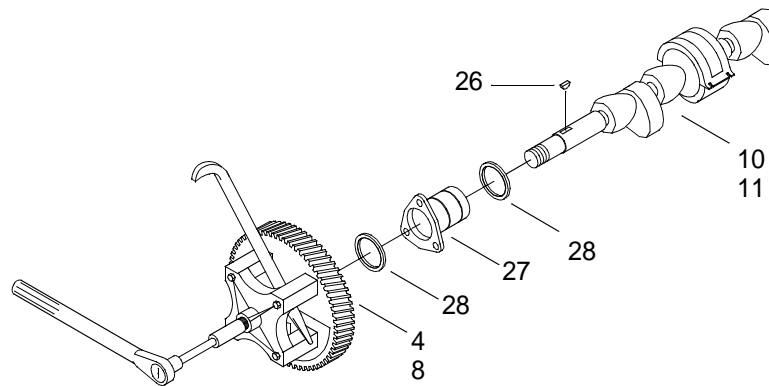

2. Using cam gear puller, J 1902-1 remove cam gears (4 and 8).
3. Remove woodruff key (26) from camshaft (10 and 11).
4. Remove end (rear) bearings (27) and thrust washers (28) from camshafts (10 and 11) and discard thrust washers (28).
5. Remove six lock rings (29) and three intermediate cam bearing sets (30) from camshafts (10 and 11).

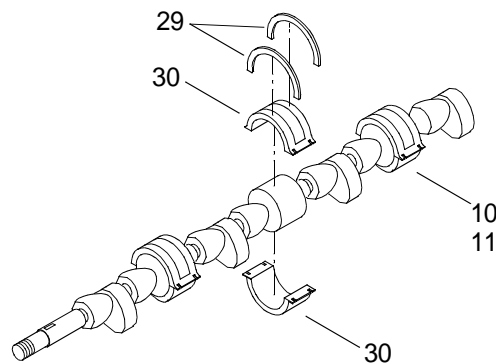

ASSEMBLE CAMSHAFT

WARNING



CHEMICAL



EYE PROTECTION

NOTE

This procedure is typical for both camshafts.

1. Apply grease to the steel faces of new thrust washers (28).

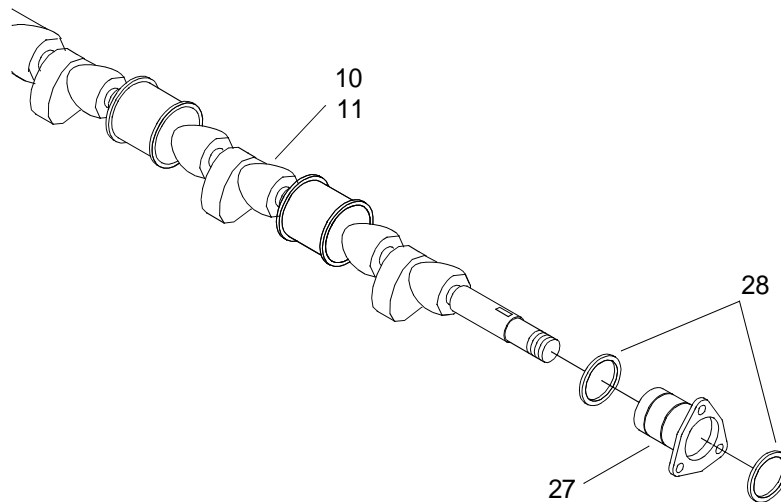

WARNING



CHEMICAL



EYE PROTECTION

2. Apply engine oil to camshaft (10 and 11) rear bearing journal.

NOTE

The steel faces of the thrust washers are to be placed next to the bearings.

3. Install new thrust washers (28), a new cam bearing (27) and then other new thrust washer (28) on camshaft (10 and 11).
4. Install a new woodruff key (26) in the keyway on camshafts (10 and 11).

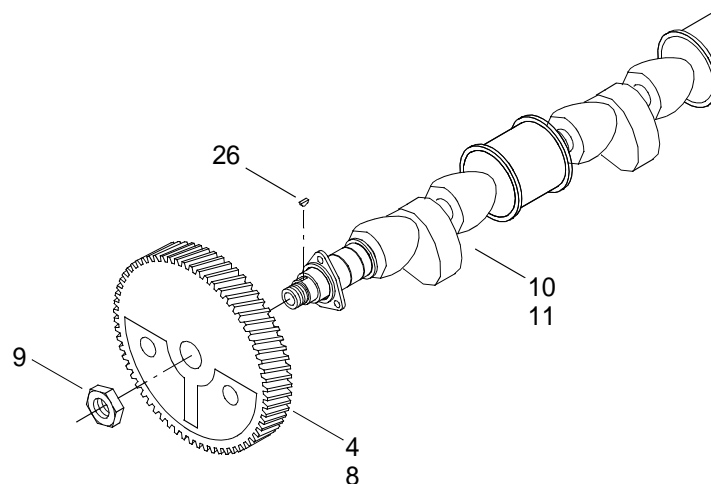

5. Using an arbor press, press the gears (4 and 8) onto camshafts (10 and 11).
6. Install nuts (9) onto camshafts (10 and 11) finger tight.

WARNING

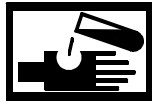
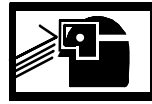
**CHEMICAL****EYE PROTECTION**

7. Apply engine oil onto intermediate cam bearing journals on camshafts (10 and 11).

NOTE

The top bearing half has a hole in it, the bottom half bearing has no hole.

8. Put six halves of intermediate bearings (30) onto the bearing journals of camshafts (10 and 11).

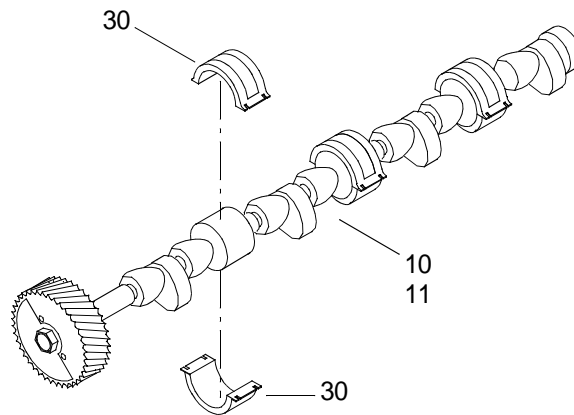

CAUTION

Both ends of the bearing lock ring must cover the split between the bearing halves and they must be installed on the bottom half of the bearing. Failure to comply may result in damage to the engine.

9. Install six lock rings (29) over the bottom halves of the bearings (30).

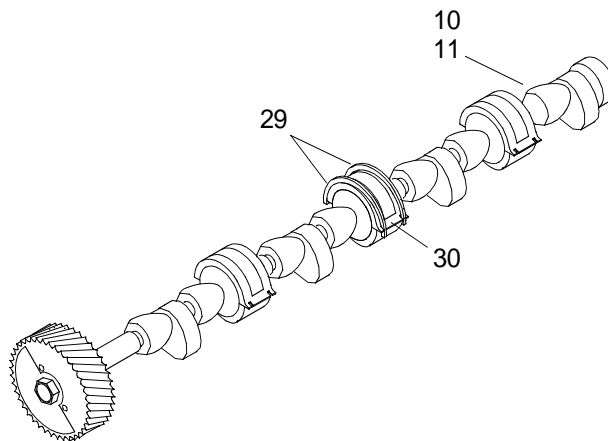

INSTALL CAMSHAFTS

1. On the rear of engine, align the crankshaft gear (31) and the idler gear (32) so that the “R” on the teeth of each gear line up.

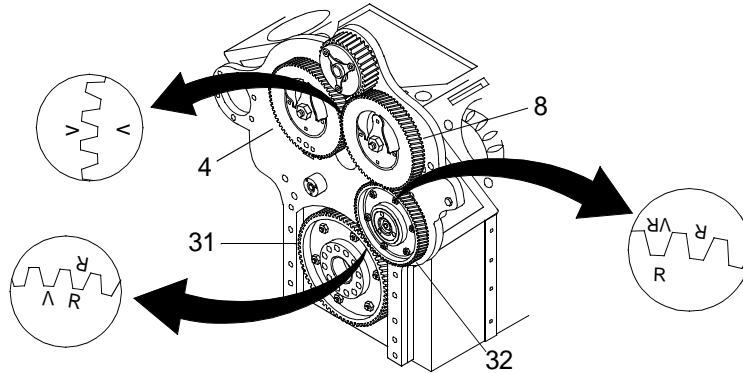

2. Install the right-hand camshaft (11) into the engine block (21).

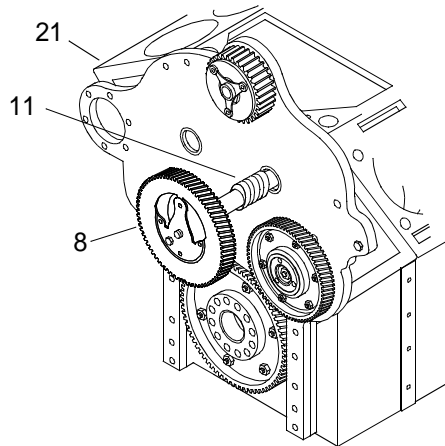

3. Align the right cam gear (8) so that the “R” on the idler gear (32) lines up with the “VR” on the cam gear (8).
4. Install the left-hand camshaft (10) into the engine block (21).

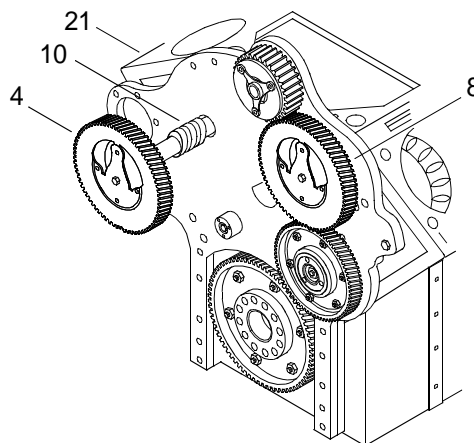

5. Align the left cam gear (4) so that the “V” on the left cam gear (4) lines up with the “V” on the right cam gear (8).

6. Push cam gears (4 and 8) all the way into place so that the cam gears, the idler gear and the crankshaft gear are fully meshed.
7. Check the timing and correct as necessary.

NOTE

In order to install rear bearing screws it will be necessary to rotate the camshaft gears.

8. Turn camshaft gears (4 and 8) to reach all rear bearing screw holes.
9. Install six screws (19) and lock washers (20) into both rear bearings (27).

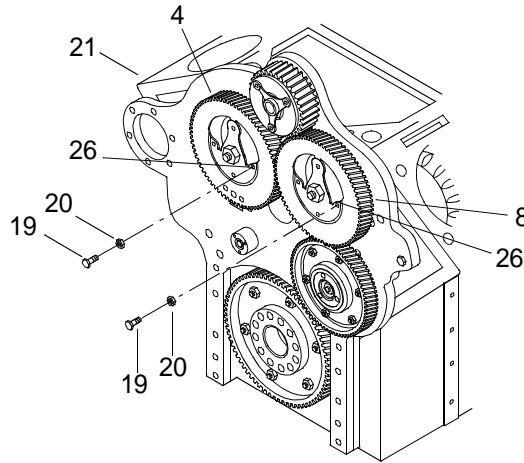

10. Using torque wrench, torque screws (19) to 480 ft lbs (54 N-m).
11. Align holes in six intermediate bearings (30) on camshafts (10 and 11) with threaded holes in the engine block (21).

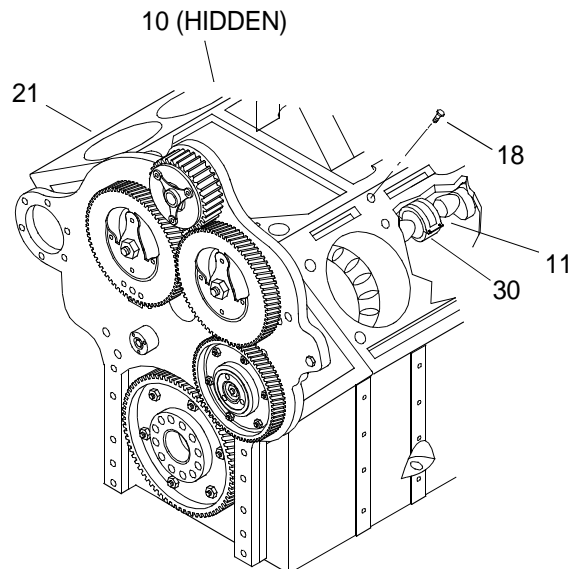

12. Install intermediate bearing lock screws (18).
13. Using torque wrench, torque lock screws (18) to 240 ft lbs (27 N-m).

14. On the front of engine, apply engine oil to both front cam bearing journals.

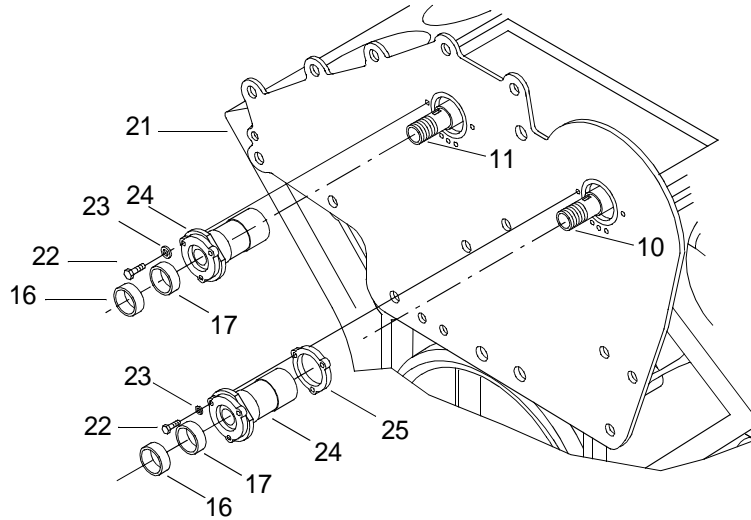

NOTE

Only the left cam bearing has a gasket.

15. Install gasket (25) on left cam bearing (10).
16. Install front cam bearings (24) on camshaft (10 and 11).
17. Install six screws (22) and washers (23) in front cam bearings (24).
18. Using torque wrench, torque screws (22) to 480 ft lbs (54 N-m).
19. Install oil seal (16) and spacer (17).
20. Install woodruff key (15) into camshaft (10).

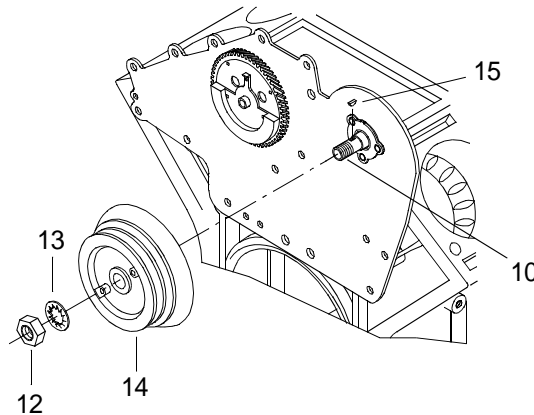

21. Install pulley (14) onto camshaft (10).

22. Install nut (12) and lock washer (13) onto camshaft (10) and tighten finger tight.

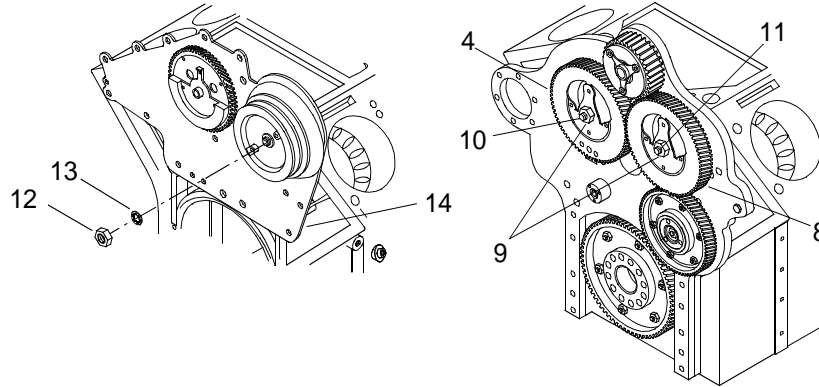

23. Place a rag between the teeth of the camshaft gears (4 and 8).

24. Using torque wrench, torque nuts (9) on the back side of the crankshafts (10 and 11) to 300 ft lbs (407 N-m).

25. Using torque wrench, torque nut (12) on the front end of cam shaft (10) to 300 ft lbs (407 N-m).

26. Remove rag from between gears (4 and 8).

27. Position two retainers (3 and 7) on cam shaft gears (4 and 8).

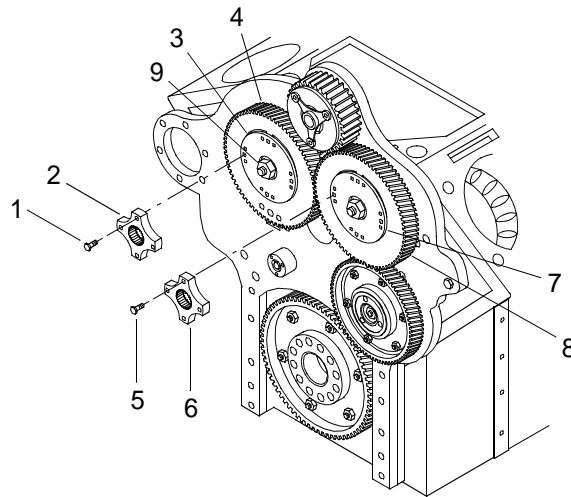

28. Position two adaptors (2 and 6) on retainers (3 and 7).

29. Install eight screws (1 and 5) securing adaptors and retainers to cam gear.

30. Using torque wrench, torque screws (1 and 5) to 480 ft lbs (54 N-m).

NOTE

If measurement exceeds specified limits, the camshaft (10) must be replaced.

31. Using a feeler gauge, verify the clearance between thrust washer (28) and the shoulder of the camshaft (10) is between 0.004 in. to 0.018 in.

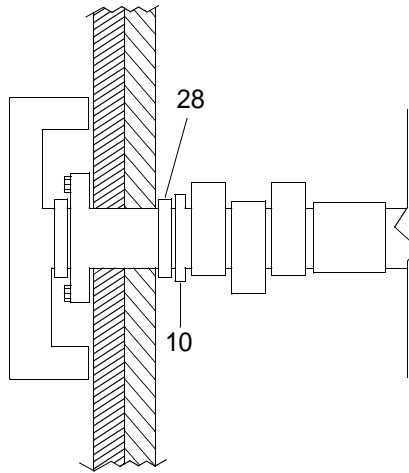
**NOTE**

If measurement exceeds specified limits, the camshaft gears (4 and 8) must be replaced as a pair.

32. Using a dial indicator, verify that the backlash between gears (4 and 8) is between 0.002 in. to 0.010 in.

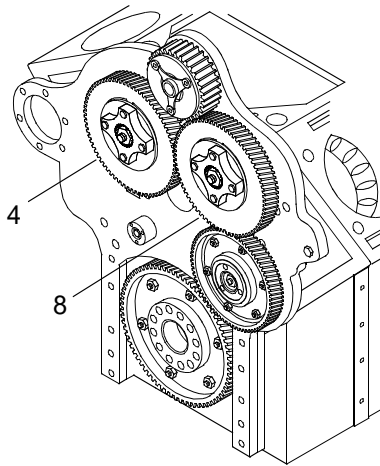

33. Install fresh water cooling system pump drive gear. (WP 0153 00)
34. Install front balance weight cover. (WP 0076 00)
35. Install forward lifting bracket. (WP 0139 00)
36. Install camshaft accessory drive pulley. (WP 0066 00)
37. Install fresh water cooling system water pump. (WP 0152 00)
38. Install main fuel filter cartridge. (WP 0079 00)

39. Install heat exchanger. (WP 0138 00)
40. Service fresh water cooling system. (WP 0133 00)
41. Install fresh water cooling system filter element. (WP 0140 00)
42. Install flywheel housing. (WP 0071 00)
43. Install flywheel. (WP 0069 00)
44. Install lube oil pan. (WP 0127 00)
45. Install electronic governor magnetic pick-up. (WP 0100 00)
46. Install raw water pump. (WP 0160 00)
47. Install electrical system hour meter mounting bracket. (WP 0168 00)
48. Install electrical system hour meter. (WP 0167 00)
49. Install cylinder heads. (WP 0046 00)
50. Install cylinder head poppet valve rocker arms. (WP 0048 00)
51. Install cylinder head poppet valve rocker arm covers. (WP 0043 00)
52. Install starboard fresh water outlet manifold. (WP 0151 00)
53. Install port fresh water outlet manifold. (WP 0150 00)
54. Install port thermostat housing. (WP 0145 00)
55. Install starboard thermostat housing. (WP 0144 00)
56. Install fresh water cooling system by-pass hoses. (WP 0148 00)
57. Install fuel injector control tube and lever assembly. (WP 0086 00)
58. Remove engine from stand. (WP 0032 00)
59. Install lube oil cooler. (WP 0128 00)
60. Install marine gear oil cooler mounting bracket. (WP 0164 00)
61. Install overspeed governor. (WP 0175 00)
62. Install lube oil dipstick tube assembly. (WP 0130 00)
63. Install starting motor. (WP 0170 00)
64. Install air box drains. (WP 0036 00)
65. Install air box covers. (WP 0035 00)
66. Install fuel cooler. (WP 0081 00)
67. Install marine gear oil cooler. (TM 55-1945-205-24-1-3)

- 68. Install exhaust manifolds. (WP 0163 00)
- 69. Install turbochargers. (WP 0114 00)
- 70. Install air inlet collector assembly. (WP 0104 00)
- 71. Install crankcase breather limiter assembly. (WP 0106 00)

END OF WORK PACKAGE

**GENERAL SUPPORT MAINTENANCE
CAUSEWAY FERRY
CAMSHAFT VIBRATION DAMPER
REPLACEMENT**

INITIAL SETUP:**Tools**

Tool Kit, General Mechanic's (Item 130, WP 0188 00)
Puller Kit, Universal (Slide Hammer) (Item 100, WP 0188 00)
Wrench Set, Socket (3/8 in. sqdr.) (Item 135, WP 0188 00)
Wrench, Torque (150-750 in. lbs) (Item 142, WP 0188 00)
Mallet, Rubber (Item 81, WP 0188 00)

Materials/Parts

Damper, Vibration
(72582)
NSN 2815-01-051-9849
PN 8922492
Oil, Lubricating, Engine, 30W (Item 26, WP 0187 00)

Personnel Required

Engineer 88L

References

TM 55-1945-205-10-1

Equipment Condition

SINGARS Antenna Removed. (TM 11-5820-890-10-8)
Main Navigation Mast Removed. (TM 55-1945-205-24-1-1)
Powered Section Intake Plenum Or Operators Cab Removed. (TM 55-1945-205-24-1-1)
Powered Section Engine Hatch Removed. (TM 55-1945-205-24-1-1)
Fresh Water Cooling System Drained. (WP 0134 00)
Alternator Belt Guard Removed. (TM 55-1945-205-24-1-1)
Heat Exchanger Removed (WP 0138 00)
Forward Lifting Bracket Removed. (WP 0139 00)
Fresh Water Pump Removed. (WP 0152 00)

REMOVE CAMSHAFT VIBRATION DAMPER

1. Remove bolt (1), lock washer (2) and washer (3) from vibration damper (4).

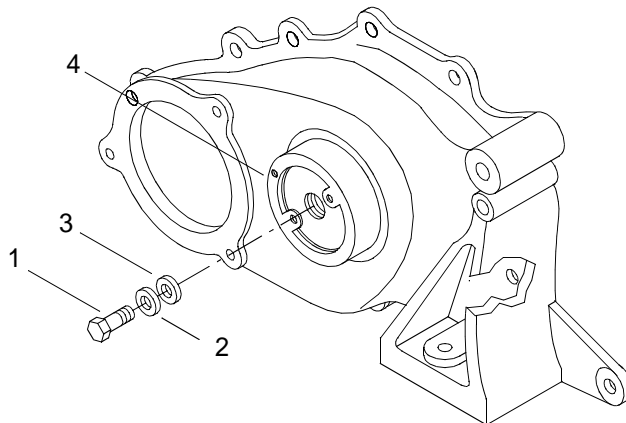

- Using universal puller kit, remove vibration damper (4) from camshaft (5). Discard vibration damper.

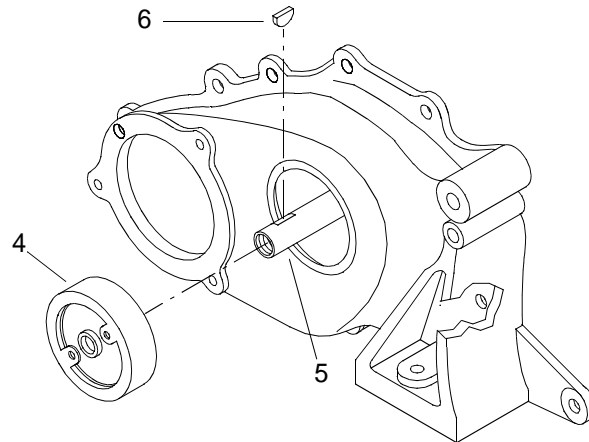

- Remove woodruff key (6) from camshaft (5).

INSTALL CAMSHAFT VIBRATION DAMPER

- Align woodruff key (6) with the woodruff key slot in camshaft (5).
- Using a rubber mallet, tap woodruff key (6) into slot until seated on camshaft (5).
- Lubricate camshaft (5) with lubricating oil.
- Install new vibration damper (4) on camshaft (5).
 - Using a rubber mallet, strike vibration damper (4) evenly on all sides until seated.
 - Install washer (3), lock washer (2) and bolt (1) on vibration damper (4).

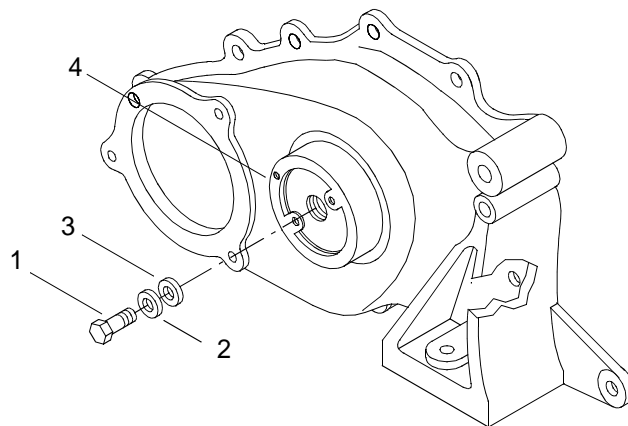

- Using a torque wrench, torque bolt (1) to 300 in-lbs (34 N-m).
- Install fresh water pump. (WP 0152 00)
- Install forward lifting bracket. (WP 0139 00)
- Install heat exchanger. (WP 0138 00)

-
7. Service fresh water cooling system. (WP 0133 00)
 8. Install powered section engine hatch. (TM 55-1945-205-24-1-1)
 9. Install powered section intake plenum or operators cab. (TM 55-1945-205-24-1-1)
 10. Install main navigation mast. (TM 55-1945-205-24-1-1)
 11. Install SINGARS antenna. (TM 11-5820-890-10-8)
 12. Perform operational checks. (TM 55-1945-205-10-1)

END OF WORK PACKAGE

**GENERAL SUPPORT MAINTENANCE
CAUSEWAY FERRY
CAMSHAFT GEARS
REPLACEMENT**

INITIAL SETUP:**Tools**

Tool Kit, General Mechanic's (Item 130, WP 0188 00)
Body, Puller (Item 11, WP 0188 00)
Indicator, Dial (Item 67, WP 0188 00)
Screwdriver Attachment Set, Socket Wrench (Item 112, WP 0188 00)
Wrench, Torque, 150-750 in. lbs (Item 142, WP 0188 00)
Wrench, Torque, 100-600 ft lbs (Item 139, WP 0188 00)
Wrench Set, Socket (3/8 sqdr) (Item 135, WP 0188 00)
Wrench Set, Socket (3/4 sqdr) (Item 134, WP 0188 00)

Materials/Parts

Cloth, Cleaning (Item 13, WP 0187 00)

Personnel Required

Engineer 88L

Equipment Condition

Crankcase Breather Limiter Removed. (WP 0106 00)
Air Inlet Collector Assembly Removed. (WP 0104 00)
Turbochargers Removed. (WP 0114 00)
Exhaust Manifolds Removed. (WP 0163 00)
Marine Gear Oil Cooler Removed. (TM 55-1945-205-24-1-3)
Fuel Cooler Removed. (WP 0081 00)
Air Box Covers Removed. (WP 0035 00)
Air Box Drains Removed. (WP 0036 00)
Starting Motor Removed. (WP 0170 00)
Lube Oil Dipstick Tube Assembly Removed. (WP 0130 00)
Overspeed Governor Removed. (WP 0175 00)
Marine Gear Oil Cooler Mounting Bracket Removed. (WP 0164 00)
Lube Oil Cooler Removed. (WP 0128 00)
Engine Installed On Stand. (WP 0032 00)
Electrical System Hour Meter Removed. (WP 0167 00)
Electrical System Hour Meter Bracket Removed. (WP 0168 00)
Raw Water Pump Removed. (WP 0160 00)
Electronic Governor Magnetic Pick-Up Removed. (WP 0100 00)
Oil Pan Removed. (WP 0127 00)
Flywheel Removed. (WP 0069 00)
Flywheel Housing Removed. (WP 0071 00)
Rear Crankshaft Oil Seal Removed. (WP 0061 00)

REMOVE CAMSHAFT GEARS

1. Remove four cap screws (1), adaptor (2) and retainer (3) from left camshaft gear (4).

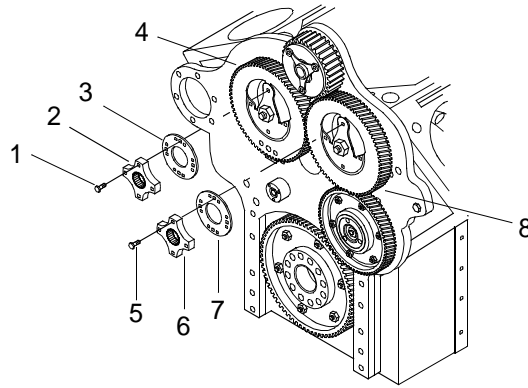

2. Remove four cap screws (5), adaptor (6) and retainer (7) from left camshaft gear (8).
3. Place a cleaning cloth between camshaft gears (4 and 8) to prevent gears from rotating.
4. Remove two hex nuts (9) from rear end of camshaft (10 and 11).

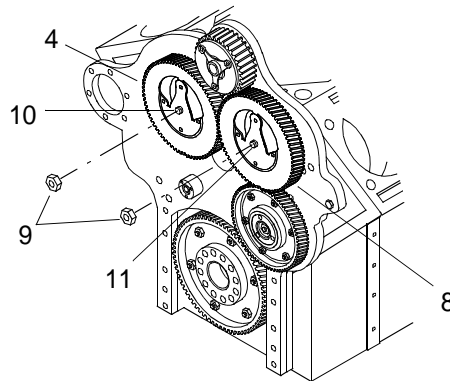

5. Remove cleaning cloth from between gears (4 and 8).
6. Remove cam gears (4 and 8) using body puller and a pry bar.

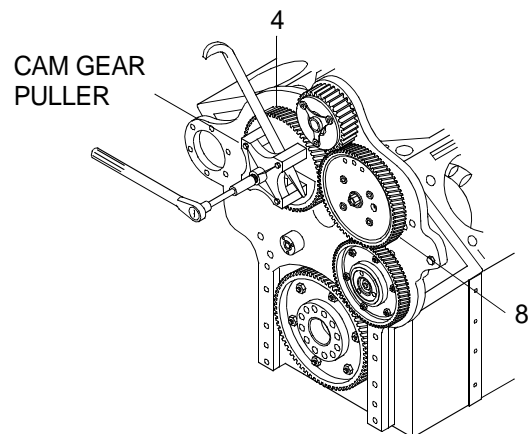

INSTALL CAMSHAFT GEARS

1. Align crankshaft gear (12) and idler gear (13) so that the “R” on the teeth of each gear line up.

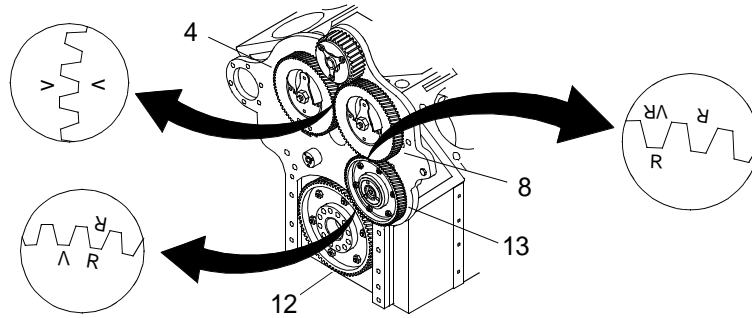

2. Install right-hand cam gear (8) onto the camshaft (11).
3. Align right cam gear (8) so that the “R” on the idler gear (13) lines up with the “VR” on the cam gear (8).
4. Install left-hand cam gear (4) onto the camshaft (10).

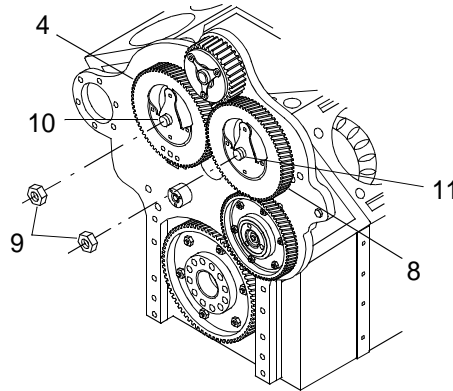

5. Align the left cam gear (4) so that the “V” on the left cam gear (4) lines up with the “V” on the right cam gear (8).
6. Install hex nuts (9) onto camshafts (10 and 11) and tighten until seated.
7. Place a cleaning cloth between the teeth of the camshaft gears (4 and 8) to prevent gears from turning.
8. Using a torque wrench, torque hex nuts (9) on the back side of the camshafts (10 and 11) to 300 ft lbs (407 N-m).

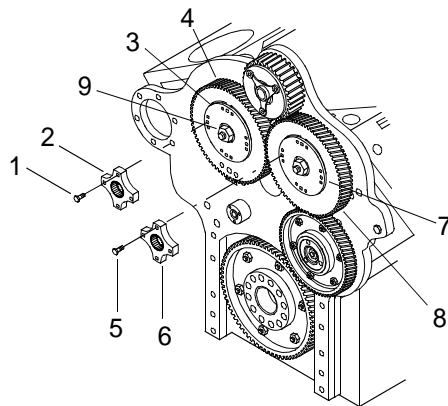

9. Position two retainers (3 and 7) on cam gears (4 and 8).
10. Position two adaptors (2 and 6) on retainers (3 and 7).
11. Install eight cap screws (1 and 5) securing adaptors and retainers to cam gear.
12. Using a torque wrench and screwdriver set, torque screws (1 and 5) to 480 in-lbs (54 N-m).
13. Remove cleaning cloth between gears (4 and 8).

CAUTION

If clearance is not within limits, the gears should be replaced.

14. Check backlash between gears (4 and 8) for a clearance of .002 in. - .010 in.
15. Install rear crankshaft oil seal. (WP 0061 00)
16. Install flywheel housing. (WP 0071 00)
17. Install flywheel. (WP 0069 00)
18. Install oil pan. (WP 0127 00)
19. Install electronic governor magnetic pick-up. (WP 0100 00)
20. Install raw water pump. (WP 0160 00)
21. Install electrical system hour meter bracket. (WP 0168 00)
22. Install electrical system hour meter. (WP 0167 00)
23. Remove engine from stand. (WP 0032 00)
24. Install lube oil cooler. (WP 0128 00)
25. Install marine gear oil cooler mounting bracket. (WP 0164 00)
26. Install overspeed governor. (WP 0175 00)
27. Install lube oil dipstick tube assembly. (WP 0130 00)
28. Install starting motor.(WP 0170 00)
29. Install air box drains. (WP 0036 00)
30. Install air box covers. (WP 0035 00)
31. Install fuel cooler. (WP 0081 00)
32. Install marine gear oil cooler. (TM 55-1945-205-24-1-3)

-
33. Install exhaust manifolds. (WP 0163 00)
 34. Install turbochargers. (WP 0114 00)
 35. Install air inlet collector assembly. (WP 0104 00)
 36. Install crankcase breather limiter. (WP 0106 00)

END OF WORK PACKAGE

**GENERAL SUPPORT MAINTENANCE
CAUSEWAY FERRY
CAMSHAFT BALANCE WEIGHT
REPLACEMENT**

INITIAL SETUP:**Tools**

Tool Kit, General Mechanic's (Item 130, WP 0188 00)
Wrench Set, Socket (3/8 in. sqdr.) (Item 135, WP 0188 00)
Wrench, Torque (150-750 in. lbs) (Item 142, WP 0188 00)

Materials/Parts

Balance, Weight
(72582)
NSN 2815-01-082-2503
PN 5144888

Personnel Required

Engineer 88L

References

TM 55-1945-205-10-1

Equipment Condition

SINGARS Antenna Removed. (TM 11-5820-890-10-8)
Main Navigation Mast Removed. (TM 55-1945-205-24-1-1)
Powered Section Intake Plenum or Operators Cab Removed. (TM 55-1945-205-24-1-1)
Powered Section Engine Hatch Removed. (TM 55-1945-205-24-1-1)
Fresh Water Cooling System Filter Removed. (WP 0140 00)
Fresh Water Cooling System Drained. (WP 0134 00)
Fresh Water Cooling System Heat Exchanger Removed. (WP 0138 00)
Fuel Filter Cartridge Removed. (WP 0079 00)
Fresh Water Pump Removed. (WP 0152 00)
Camshaft Vibration Damper Removed. (WP 0063 00)
Front Balance Weight Cover Removed. (WP 0076 00)
Fresh Water Pump Drive Gear Removed. (WP 0153 00)

REMOVE CAMSHAFT BALANCE WEIGHT

1. Remove two screws (1) from balance weight (2).

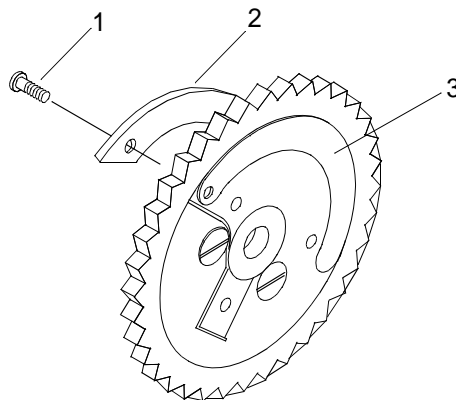

2. Remove balance weight (2) from drive gear (3) and discard balance weight (2).

INSTALL CAMSHAFT BALANCE WEIGHT

1. Align new balance weight (2) on drive gear (3).
2. Install two screws (1) in balance weight (2).
3. Using torque wrench and socket set, torque screws (1) to 420 - 480 in-lbs (47 - 54 N-m).
4. Install fresh water pump drive gear. (WP 0153 00)
5. Install front balance weight cover. (WP 0076 00)
6. Install camshaft vibration damper. (WP 0063 00)
7. Install fresh water pump. (WP 0152 00)
8. Install fuel filter cartridge. (WP 0079 00)
9. Install fresh water cooling system heat exchanger. (WP 0138 00)
10. Install fresh water cooling system filter. (WP 0140 00)
11. Service fresh water cooling system. (WP 0133 00)
12. Install powered section engine hatch. (TM 55-1945-205-24-1-1)
13. Install powered section intake plenum or operators cab. (TM 55-1945-205-24-1-1)
14. Install main navigation mast. (TM 55-1945-205-24-1-1)
15. Install SINGARS antenna. (TM 11-5820-890-10-8)
16. Perform operational checks. (TM 55-1945-205-10-1)

END OF WORK PACKAGE

**GENERAL SUPPORT MAINTENANCE
CAUSEWAY FERRY
CAMSHAFT ACCESSORY DRIVE PULLEY
REPLACEMENT**

INITIAL SETUP:**Tools**

Tool Kit, General Mechanic's (Item 130, WP 0188 00)
Puller Kit, Universal (Cross Bar) (Item 99, WP 0188 00)
Wrench, Torque (100-600 ft lbs) (Item 139, WP 0188 00)
Wrench Set, Socket (¾ in. sqdr.) (Item 134, WP 0188 00)
Mallet, Rubber (Item 81, WP 0188 00)
Gloves, Chemical (Item 52, WP 0188 00)
Goggles, Industrial (Item 54, WP 0188 00)

Materials/Parts

Pulley
(72582)
NSN 3020-01-286-3739
PN 5148959

Key
(72582)
NSN 5315-01-214-1876
PN 8926247

Oil, Lubricating, Engine, 10W (Item 25, WP 0187 00)

Personnel Required

Engineer 88L

References

TM 55-1945-205-10-1

Equipment Condition

SINGARS Antenna Removed. (TM 11-5820-890-10-8)
Main Navigation Mast Removed. (TM 55-1945-205-24-1-1)
Powered Section Operators Cab Removed. (TM 55-1945-205-24-1-1)
Powered Section Intake Plenum Removed. (TM 55-1945-205-24-1-1)
Powered Section Engine Hatch Removed. (TM 55-1945-205-24-1-1)
Fresh Water Cooling System Drained. (WP 0134 00)
Fresh Water Cooling System Heat Exchanger Removed. (WP 0138 00)
Forward Lifting Bracket Removed. (WP 0139 00)

REMOVE CAMSHAFT ACCESSORY DRIVE PULLEY

1. Remove hex nut (1) and flat washer (2) securing camshaft accessory drive pulley (3) to camshaft (4).

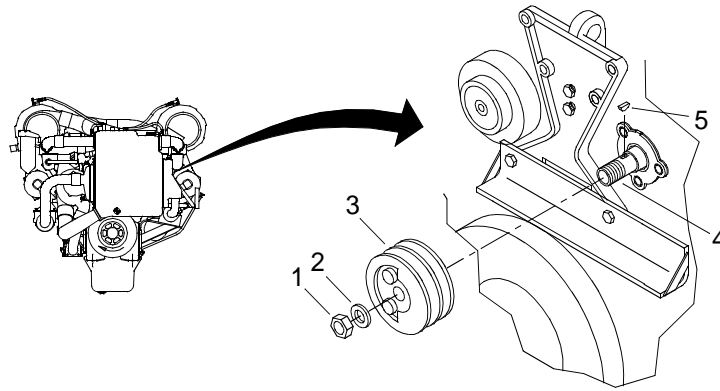

2. Attach puller to camshaft accessory drive pulley (3).
3. Remove camshaft accessory drive pulley (3) from camshaft (4). Discard camshaft accessory drive pulley (3).
4. Remove woodruff key (5) and discard.

INSTALL CAMSHAFT ACCESSORY DRIVE PULLEY

WARNING



CHEMICAL



EYE PROTECTION

1. Coat camshaft (4) and new woodruff key (5) with engine lubricating oil.

WARNING



CHEMICAL



EYE PROTECTION

2. Using a rubber mallet, tap new woodruff key (6) into slot until seated on camshaft (4).
3. Install new camshaft accessory drive pulley (3) on camshaft (4).
4. Install hex nut (1) and flat washer (2) securing camshaft accessory drive pulley (3) to camshaft (4).
5. Using a torque wrench, torque nut (1) to 300 ft lbs (407 N-m)
6. Install forward lifting bracket. (WP 0139 00)
7. Install fresh water cooling system heat exchanger. (WP 0138 00)
8. Service fresh water cooling system. (WP 0133 00)
9. Install powered section engine hatch. (TM 55-1945-205-24-1-1)

-
10. Install powered section intake plenum. (TM 55-1945-205-24-1-1)
 11. Install powered section operators cab. (TM 55-1945-205-24-1-1)
 12. Install SINGARS antenna. (TM 11-5820-890-10-8)
 13. Install main navigation mast. (TM 55-1945-205-24-1-1)
 14. Perform operational checks. (TM 55-1945-205-10-1)

END OF WORK PACKAGE

**GENERAL SUPPORT MAINTENANCE
CAUSEWAY FERRY
CAMSHAFT IDLER GEARS
REMOVAL AND INSTALLATION**

INITIAL SETUP:**Tools**

Tool Kit, General Mechanic's (Item 130, WP 0188 00)
Indicator, Dial (Item 67, WP 0188 00)
Wrench, Torque (0-175 ft lbs) (Item 138, WP 0188 00)

Materials/Parts

Cloth, Cleaning (Item 13, WP 0187 00)

Personnel Required

Engineer 88L

Equipment Condition

Crankcase Breather Limiter Removed. (WP 0106 00)
Air Inlet Collector Assembly Removed. (WP 0104 00)
Turbochargers Removed. (WP 0114 00)
Exhaust Manifolds Removed. (WP 0163 00)
Marine Gear Oil Cooler Removed. (TM 55-1945-205-24-1-3)
Fuel Cooler Removed. (WP 0081 00)
Air Box Covers Removed. (WP 0035 00)
Air Box Drains Removed. (WP 0036 00)
Starting Motor Removed.(WP 0170 00)
Lube Oil Dipstick Tube Assembly Removed. (WP 0130 00)
Overspeed Governor Removed. (WP 0175 00)
Marine Gear Oil Cooler Mounting Bracket Removed. (WP 0164 00)
Lube Oil Cooler Removed. (WP 0128 00)
Engine Installed On Stand. (WP 0032 00)
Electrical System Hour Meter Removed. (WP 0167 00)
Electrical System Hour Meter Bracket Removed. (WP 0168 00)
Raw Water Pump Removed. (WP 0160 00)
Electronic Governor Magnetic Pick-Up Removed. (WP 0100 00)
Oil Pan Removed. (WP 0127 00)
Flywheel Removed. (WP 0069 00)
Flywheel Housing Removed. (WP 0069 00)
Rear Crankshaft Oil Seal Removed. (WP 0061 00)

REMOVE IDLER GEAR AND HUB ASSEMBLY

1. Rotate engine crank shaft gear (1) until all gear train aligning marks are aligned.

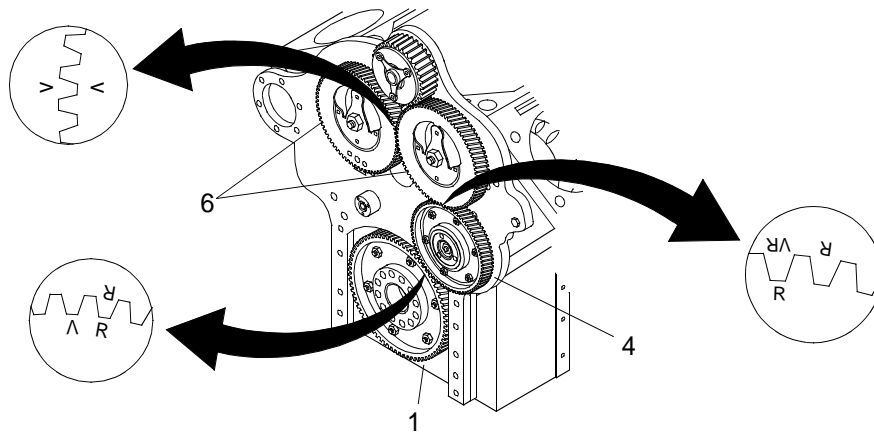

- Remove cap screw (2) and flat washer (3) securing idler gear (4) to engine (5).

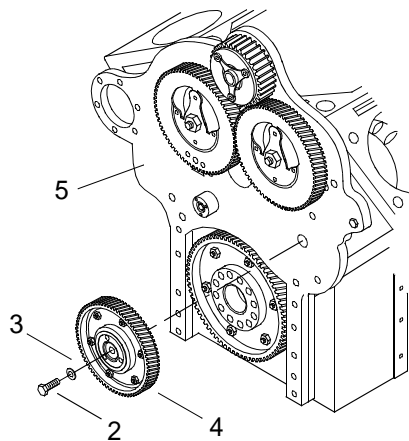

- Remove idler gear (4) from engine (5).

INSTALL IDLER GEAR AND HUB ASSEMBLY

- Verify that the alignment marks on camshaft gears (6) and the crankshaft gear (1) are properly positioned.
- Install idler gear (4) flat against engine (5) with alignment marks aligned.
- Install cap screw (2) and flat washer (3) on idler gear (4).
- Place a cleaning cloth between camshaft gears (6) to stop gears (6) from rotating.
- Using torque wrench, torque cap screw (2) to 80-90 ft lbs (108-122 N-m)
- Remove cleaning cloth.
- Using a dial indicator check the backlash of the idler gear (4).
- Verify that backlash is between 0.002 to 0.008 in. (0.00508 to 0.2032 cm) on new gears and does not exceed 0.010 in. (0.0254 cm) on used gears.

NOTE

If tolerances are exceeded, camshaft gears will be replaced as a set.

9. Install rear crankshaft oil seal. (WP 0061 00)
10. Install flywheel housing. (WP 0071 00)
11. Install flywheel. (WP 0069 00)
12. Install oil pan (WP 0127 00)
13. Install electronic governor magnetic pick-up. (WP 0100 00)
14. Install raw water pump. (WP 0160 00)
15. Install electrical system hour meter bracket. (WP 0168 00)
16. Install electrical system hour meter. (WP 0167 00)
17. Remove engine from stand. (WP 0032 00)
18. Install lube oil cooler. (WP 0128 00)
19. Install marine gear oil cooler mounting. (WP 0164 00)
20. Install overspeed governor. (WP 0175 00)
21. Install lube oil dipstick tube assembly. (WP 0130 00)
22. Install starting motor.(WP 0170 00)
23. Install air box drains. (WP 0036 00)
24. Install air box covers. (WP 0035 00)
25. Install fuel cooler. (WP 0081 00)
26. Install marine gear oil cooler. (TM 55-1945-205-24-1-3)
27. Install exhaust manifolds. (WP 0163 00)
28. Install turbochargers. (WP 0114 00)
29. Install air inlet collector assembly. (WP 0104 00)
30. Install crankcase breather limiter. (WP 0106 00)

END OF WORK PACKAGE

**GENERAL SUPPORT MAINTENANCE
CAUSEWAY FERRY
CAMSHAFT IDLER GEAR
REPAIR**

INITIAL SETUP:**Tools**

Tool Kit, General Mechanic's (Item 130, WP 0188 00)
 Wrench, Torque (0-175 ft lbs) (Item 138, WP 0188 00)
 Wrench, Torque (150-750 in. lbs) (Item 142, WP 0188 00)
 Wrench Set, Socket (3/8 in. sqdr.) (Item 135, WP 0188 00)
 Press, Arbor, Hand Operated (Item 97, WP 0188 00)
 Plate Kit, Gear Bear (Item 92, WP 0188 00)
 Caps, Vice Jaw, Copper (Item 24, WP 0188 00)
 Scale, Tension (Item 111, WP 0188 00)
 Apron, Utility (Item 8, WP 0188 00)
 Gloves, Chemical (Item 52, WP 0188 00)
 Goggles, Industrial (Item 54, WP 0188 00)

Materials/Parts

Bolt
 (72582)
 NSN 5306-01-078-4981
 PN 5103534
 Qty 6
 Cloth, Cleaning (Item 13, WP 0187 00)
 Cleaning Compound (Item 10, WP 0187 00)
 Lumber, Softwood, Dimension (2 in. X 4 in. X 6 ft Min Wooden Blocks) (Item 23, WP 0187 00)
 Qty 2
 Dowel, Wood (Item 17, WP 0187 00)
 Cord, Fibrous (Item 15, WP 0187 00)
 Oil, Lubricating, Engine, 10W (Item 25, WP 0187 00)

Personnel Required

Engineer 88L

DISASSEMBLE IDLER GEAR AND HUB ASSEMBLY

1. Remove six self-locking bolts (1) from retainer (2) and discard.

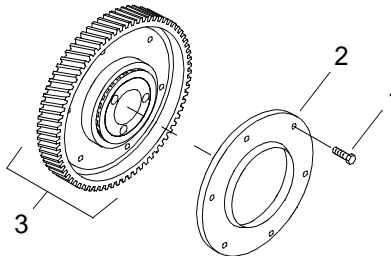

2. Remove retainer (2) from idler gear and hub assembly (3).

WARNING

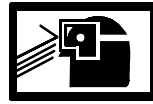
**CHEMICAL****EYE PROTECTION**

3. Clean excess grease and oil from idler gear and hub assembly (3) with cleaner.
4. Place idler gear and hub assembly (3) in an arbor press.

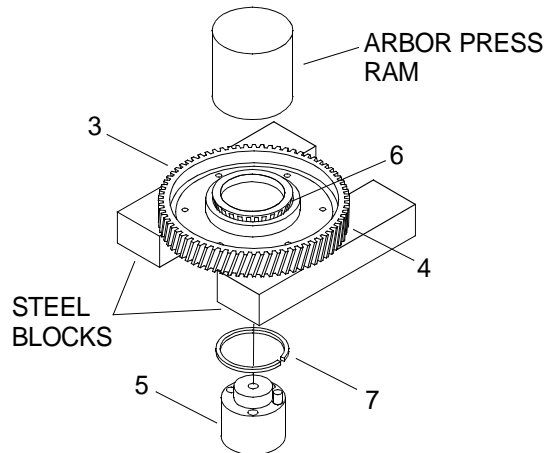

5. Support idler gear and hub assembly (3) with steel blocks provided with the arbor press.

WARNING

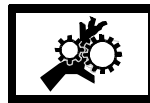
**EYE PROTECTION****MOVING PARTS**

CAUTION

While removing and installing the hub, idler gear and bearings must be rotated to prevent damage to bearings and bearing cups. Failure to comply could cause damage to equipment.

6. Rotate gear (4) while pressing the hub (5) out of the idler gear bearing (6).
7. Remove idler gear (4) from the arbor press.

8. Remove bearings (6) from idler gear (4).

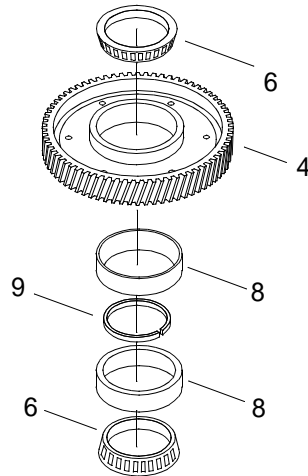

9. Remove inner spacer ring (7) from hub (6).
10. Support idler gear (4) with wooden wedges.

CAUTION

Do not remove bearing cups unless bearings and bearing cups are to be replaced, failure to comply may result in damage to equipment.

11. Using a brass drift and a hammer, tap the bearing cups (8) and spacer rings (9) out of idler gear (4).

CLEAN IDLER GEAR AND HUB ASSEMBLY

WARNING

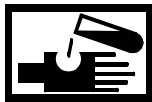

CHEMICAL



EYE PROTECTION

1. Clean all parts thoroughly using cleaning compound and cleaning cloth.

WARNING



CHEMICAL



EYE PROTECTION

Do not exceed 40 PSI (276 kPa) when using compressed air for drying components. Failure to comply could result in serious injury to personnel.

2. Dry all parts thoroughly with compressed air.

INSPECT IDLER GEAR AND HUB ASSEMBLY

1. Inspect idler gear (4) for corrosion, pitting or cracking. Replace damaged part.
2. Inspect idler hub (5) for corrosion, pitting, cracking and brinelling. Replace damaged part.
3. Inspect bearings (6) for corrosion, pitting, cracking and brinelling. Replace damaged part.
4. Inspect spacer rings (7, 9) for corrosion, pitting or cracking. Replace damaged part.
5. Inspect bearing cups (8) for corrosion, pitting, cracking and brinelling. Replace damaged part.

ASSEMBLE IDLER GEAR AND HUB ASSEMBLY

WARNING

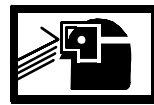

CHEMICAL

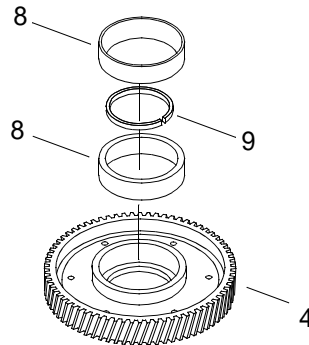
EYE PROTECTION

1. Lubricate inner surface of idler gear (4) with lubricating oil.

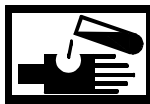

2. Support idler gear (4), shoulder side down, on the bed of the arbor press.

WARNING

CHEMICAL

EYE PROTECTION

3. Lubricate both bearing cups (8) with lubricating oil.
4. Position a bearing cup (8), number side up, on the idler gear (4).
5. Using an arbor press, press the bearing cup (8) into the idler gear (4).
6. Install spacer ring (9) on face of bearing cup (8).
7. Position the other bearing cup (8), number side down, on the idler gear (4).
8. Using an arbor press, press the bearing cup (8) into the idler gear (4).

9. Remove idler gear (4) from arbor press.

WARNING



CHEMICAL

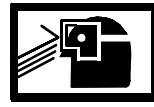

EYE PROTECTION

10. Lubricate idler gear hub (5) with lubricating oil.

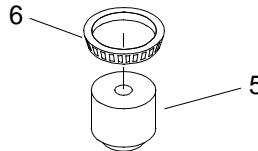

11. Support idler gear hub (5) with steel blocks provided with the arbor press.

WARNING



CHEMICAL

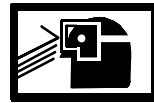

EYE PROTECTION

12. Lubricate both bearings (6) with lubricating oil.

13. Place bearing (6), numbered side up, on the hub (5).

WARNING



EYE PROTECTION

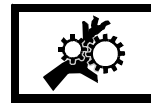

MOVING PARTS

14. Using an arbor press, press bearing (6) on hub (5) until bearing (6) is flush with hub (5).

15. Turn hub (5) and bearing (6) over.

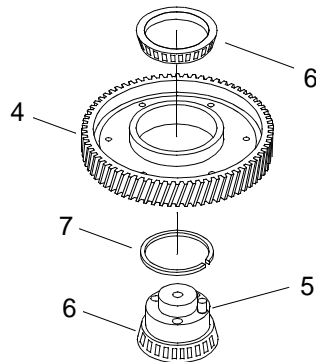

16. Install inner spacer (7) over hub (5).
17. Install idler gear (4) over hub (5) and bearing (6).
18. Place other bearing (6) numbered side up on hub (5).

WARNING



EYE PROTECTION



MOVING PARTS

19. Using an arbor press, press bearing (6) onto hub (5) while rotating idler gear and hub assembly (3).
20. Mount idler gear and hub assembly (3) in a vice equipped with soft jaw vice caps.
21. Attach plates (10 and 11) to idler gear and hub assembly (3) with cap screw (12) and hex nut (13).
22. Using a torque wrench, torque cap screw (12) and hex nut (13) to 90 ft lbs (122 N-m).
23. Attach plate (14) to idler gear and hub assembly (3) with three cap screws (15).

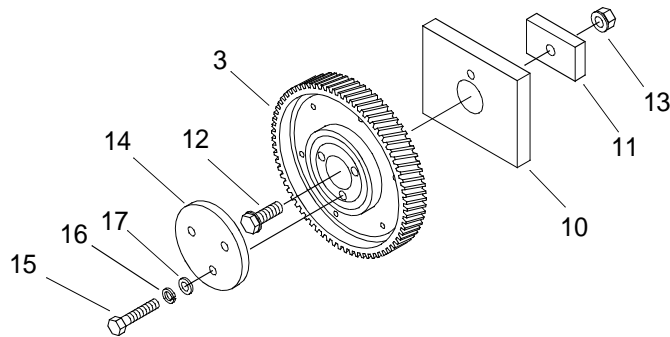

24. Using torque wrench and socket set, torque cap screws (15) to 160 in. lbs (122 N-m).
25. Remove idler gear and hub assembly (3) from vise.

TEST BEARING PRELOAD

1. Mount idler gear and hub assembly (3) in vise by plate (11).

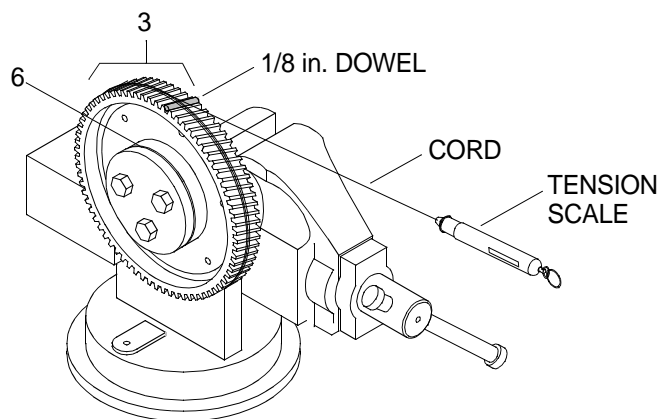

- a. Cut a piece of dowel the same width as the idler gear and hub assembly (3).
- b. Tie twine around dowel.
- c. Wedge the dowel in the teeth of idler gear and hub assembly (3).
- d. Wrap twine around idler gear and hub assembly (3) several times.
- e. Attach other end of the twine to the tension scale.

NOTE

The bearing preload should measure between ½ lb (0.23 Kg) and 4 lb (1.8 Kg).

- f. Pull the tension scale to rotate idler gear and hub assembly (3) and observe the reading on the tension scale.

NOTE

The maximum difference between pulls is 2 lb 11 oz (1.22 Kg).

- g. Repeat step f three times.
2. Remove three cap screws (15) and plate (14) from idler gear and hub assembly (3).

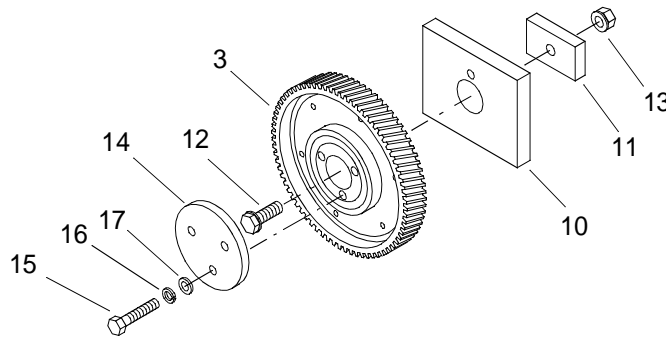

3. Remove cap screw (12), hex nut (13) and plates (10 and 11) from idler gear and hub assembly (3).
4. Install retainer (2) on idler gear and hub assembly (3).

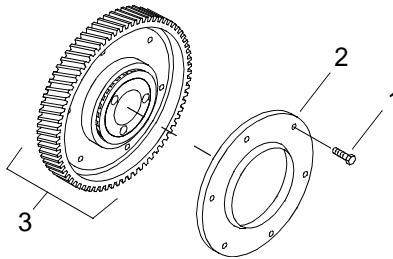

5. Install six new self-locking bolts (1) on retainer (2).

END OF WORK PACKAGE

**GENERAL SUPPORT MAINTENANCE
CAUSEWAY FERRY
FLYWHEEL
REMOVAL AND INSTALLATION**

INITIAL SETUP:**Tools**

Tool Kit, General Mechanic's (Item 130, WP 0188 00)
Alignment Stud, Flywheel Housing (Item 5, WP 0188 00)
Qty 2
Lifting Sling, Flywheel (Item 77, WP 0188 00)
Hoist, Chain (Item 65, WP 0188 00)
Wrench, Torque (0-175 ft lbs) (Item 138, WP 0188 00)
Gloves, Men's and Woman's (Leather Palm) (Item 53, WP 0188 00)
Gloves, Chemical (Item 52, WP 0188 00)
Goggles, Industrial (Item 54, WP 0188 00)

Materials/Parts

Antiseize Compound (Item 06, WP 0187 00)
Rags, Wiping (Item 28, WP 0187 00)

Personnel Required

Engineer 88L

References

TM 55-1945-205-10-1

Equipment Condition

SINCGARS Antenna Removed. (TM 11-5820-890-10-8)
Navigation Mast Assembly Removed. (TM 55-1945-205-24-1-1)
Operators Cab or Air Intake Plenum Removed. (TM 55-1945-205-24-1-1)
Powered Section Engine Hatch Removed. (TM 55-1945-205-24-1-1)
Marine Gear To Transfer Case Machinery Guard Removed. (TM 55-1945-205-24-1-1)
Marine Gear To Transfer Case Drive Shaft Removed. (TM 55-1945-205-24-1-1)
Marine Gear Drained. (TM 55-1945-205-24-1-3)
Electronic Control Valve Removed. (TM 55-1945-205-24-1-3)
Hydraulic Pump Removed. (TM 55-1945-205-24-1-1)
Marine Gear Oil Pump Removed. (TM 55-1945-205-24-1-3)
Marine Gear Removed. (TM 55-1945-205-24-1-3)

REMOVE FLYWHEEL**NOTE**

The following procedure is typical for the removal and installation of the flywheel from both the port and starboard engine.

1. Remove two flywheel bolts (1) 180° apart from one another.

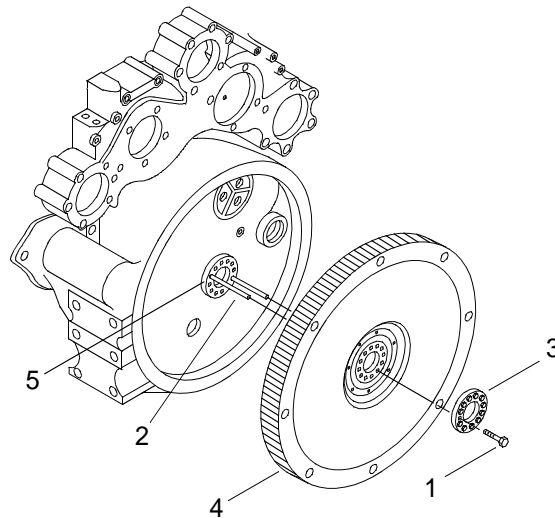

2. Install two flywheel housing alignment studs (2) in flywheel bolt holes.
3. Remove remaining ten flywheel bolts (1) and scuff plate (3) from flywheel (4).
4. Attach flywheel lifting sling to flywheel (4).
5. Attach chain hoist to the flywheel lifting sling to support the flywheel (4).

WARNING



HEAVY PARTS

6. Remove flywheel (4) from the crankshaft (5).

INSTALL FLYWHEEL

NOTE

New flywheel bolts should be used. If the old flywheel bolts are determined serviceable they should be cleaned thoroughly before reuse.

The flywheel bolt tap depth in the 8V92 engine crankshaft has been shortened from 2.620 in. to 1.620 in., starting with engine serial number 8VF-3120. With this change the shorter flywheel bolts can be used on the older engines. The longer bolts cannot be used on the newer engines.

1. Attach flywheel lifting sling and chain hoist to the new flywheel (4).
2. Using the flywheel housing alignment studs (2), install the flywheel (4) on the crankshaft (5) and align the bolt holes in the flywheel (4) with the bolt holes in the crankshaft (5).

WARNING

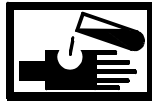
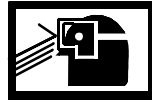
**CHEMICAL****EYE PROTECTION**

CAUTION

**Do not allow grease to get between the flywheel and the crankshaft.
Maximum friction is required. Failure to comply may result in damage to engine.**

3. Coat ten flywheel bolts (1) with antiseize compound.

WARNING

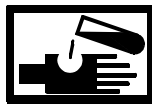
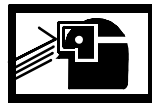
**CHEMICAL****EYE PROTECTION**

4. Using wiping rag, wipe excess antiseize compound from ten flywheel bolts (1)
5. Install scuff plate (3) on crankshaft (5).

WARNING

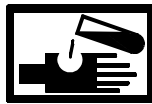
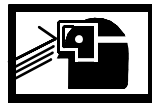
**CHEMICAL****EYE PROTECTION**

6. Install ten flywheel bolts (1) into the crankshaft (5).
7. Remove two flywheel housing alignment studs (2).

WARNING

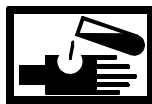
**CHEMICAL****EYE PROTECTION**

8. Coat two flywheel bolts (1) with antiseize compound.

WARNING

**CHEMICAL****EYE PROTECTION**

9. Using wiping rag, wipe excess antiseize compound from two flywheel bolts (2).

WARNING

**CHEMICAL****EYE PROTECTION**

10. Install remaining two flywheel bolts (1) in the crankshaft (4).
11. Using torque wrench, torque flywheel bolts (1) to 50 ft lbs (68 N-m).
12. Turn flywheel bolts (1) an additional 90° to 120° to obtain the proper clamping.
13. Install marine gear. (TM 55-1945-205-24-1-3)
14. Install marine gear oil pump. (TM 55-1945-205-24-1-3)
15. Install hydraulic pump. (TM 55-1945-205-24-1-1)
16. Install electronic control valve. (TM 55-1945-205-24-1-3)
17. Service marine gear. (TM 55-1945-205-24-1-3)
18. Install marine gear to transfer case drive shaft. (TM 55-1945-205-24-1-1)
19. Install marine gear to transfer case machinery guard. (TM 55-1945-205-24-1-1)
20. Install powered section engine hatch. (TM 55-1945-205-24-1-1)
21. Install operators cab or air intake plenum. (TM 55-1945-205-24-1-1)
22. Install navigation mast assembly. (TM 55-1945-205-24-1-1)
23. Install SINGARS antenna. (TM 11-5820-890-10-8)
24. Perform operational checks. (TM 55-1945-205-10-1)

END OF WORK PACKAGE

**GENERAL SUPPORT MAINTENANCE
CAUSEWAY FERRY
FLYWHEEL
REPAIR**

INITIAL SETUP:**Tools**

Tool Kit, General Mechanic's (Item 130, WP 0188 00)
Torch Set, Cutting and Welding (Item 132, WP 0188 00)
Goggles, Plate, Welders (Item 55, WP 0188 00)
Mittens, Heat Protective (Item 83, WP 0188 00)
Tongs, Blacksmiths (Item 128, WP 0188 00)
Apron, Utility (Item 8, WP 0188 00)
Gloves, Chemical (Item 52, WP 0188 00)
Goggles, Industrial (Item 54, WP 0188 00)

Materials/Parts

Lumber, Softwood, Dimension (2 in. X 4 in. X 6 ft Min Wooden Blocks) (Item 23, WP 0187 00)
Qty 2
Cleaning Compound (Item 10, WP 0187 00)
Rags, Wiping (Item 28, WP 0187 00)

Personnel Required

Engineer 88L

DISASSEMBLE FLYWHEEL

1. Support the flywheel (1) on a wooden wedge just slightly smaller than the ring gear (2) with the ring gear facing down.

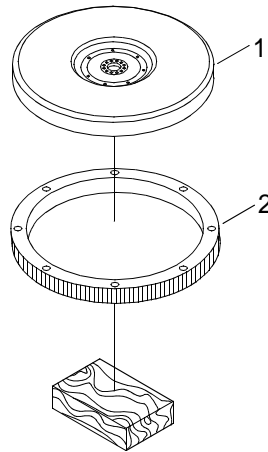

WARNING



EYE PROTECTION

NOTE

Note the direction of the chamfer on the ring gear.

- Using a brass drift and a hammer, drive the ring gear (2) off of the flywheel (1), working your way around the ring gear (2) and being careful not to bind the ring gear.

CLEAN FLYWHEEL

WARNING

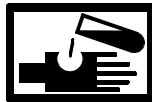

CHEMICAL



EYE PROTECTION

- Using wiping rag and cleaning compound, clean flywheel (1) and ring gear (2).

WARNING



CHEMICAL

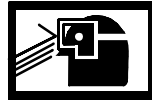

EYE PROTECTION

Air pressure should not exceed 40 PSI (276 kPa). Failure to comply could result in serious injury to personnel.

- Dry parts using compressed air.

INSPECT FLYWHEEL

- Inspect ring gear (2) for cracks or excessive wear. Replace defective part.
- Inspect butt end of the crankshaft and the flywheel contact surfaces for fretting or brinelling. Replace defective part.
- Inspect bolt holes in the flywheel to ensure they are not out of round or damaged. Replace defective part.

ASSEMBLE FLYWHEEL

1. Support flywheel (1), ring step side up, and ring gear (2) on a metal surface.

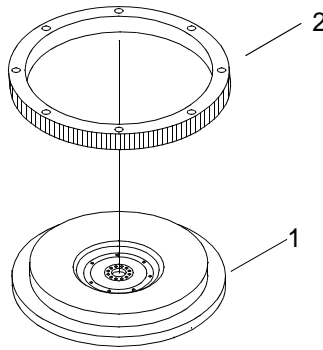

WARNING

**HOT AREA****EYE PROTECTION**

2. Using torch set and heat protective mittens, flash heat the ring gear uniformly.
3. Using tongs, place ring gear (2) over flywheel (1) with the chamfer on the ring gear facing the correct direction.
4. Using a ball peen hammer, tap the ring gear (2) onto the flywheel (1) ensuring the ring gear is completely seated on the flywheel.

END OF WORK PACKAGE

**GENERAL SUPPORT MAINTENANCE
CAUSEWAY FERRY
FLYWHEEL HOUSING
REPLACEMENT**

INITIAL SETUP:**Tools**

Tool Kit, General Mechanic's
(Item 130, WP 0188 00)
Alignment Stud, Flywheel Housing
(Item 5, WP 0188 00)
Apron, Utility (Item 8, WP 0188 00)
Gloves, Chemical (Item 52, WP 0188 00)
Goggles, Industrial (Item 54, WP 0188 00)
Wrench, Torque (0-175 ft lbs)
(Item 138, WP 0188 00)
Wrench, Torque (150-750 in. lbs)
(Item 142, WP 0188 00)
Wrench Set, Socket (3/8 in. sqdr.)
(Item 135, WP 0188 00)
Bolt, Eye (Item 12, WP 0188 00)
Qty 2
Sling 5300 lbs 6 ft (Green)
(Item 118, WP 0188 00)
Qty 4
Shackle, 1/2 in., 2 ton (Item 115, WP 0188 00)
Qty 4

Materials/Parts

Housing, Flywheel
(72582)
NSN 2815-01-332-1960
PN 8925167
Gasket
(72582)
NSN 5330-01-058-0584
PN 5144875
Gasket
(72582)
NSN 5330-01-088-5984
PN 5104507
Qty 3
Gasket
(72582)
NSN 5330-01-079-9963
PN 5104506
Screw, Cap, Hexagon Head
(72582)
NSN 5306-00-894-2381
PN 5121466
Qty 4

Materials/Parts (Continued)

Screw, Cap, Hexagon Head
(72582)
NSN
PN 5148999
Qty 3
Screw, Cap, Hexagon Head
(55380)
NSN 5306-00-865-4942
PN 271570
Qty 2
Screw, Cap, Hexagon Head
(06085)
NSN 5306-01-345-9028
PN 8297582
Qty 6
Screw, Cap, Hexagon Head
(72582)
NSN 5306-01-084-4413
PN 5103530
Screw, Cap, Hexagon Head
(80204)
NSN 5305-00-071-2076
PN B1821BH050C325N
Qty 6
Screw, Cap, Hexagon Head
(80204)
NSN 5305-00-068-0510
PN B1821BH038C100N
Qty 6
Oil, Lubricating, Engine, 10W
(Item 25, WP 0187 00)
Grease, Automotive and Artillery
(Item 20, WP 0187 00)
Sealing Compound, (Pipe Sealant)
(Item 29, WP 0187 00)
Sealing Compound, (Ultra-Blue)
(Item 30, WP 0187 00)
Cloth, Abrasive (Item 12, WP 0187 00)

Personnel Required

Engineer 88L (2)

Equipment Condition

Crankcase Breather Limiter Removed. (WP 0106 00)
 Air Inlet Collector Assembly Removed. (WP 0104 00)
 Turbochargers Removed. (WP 0114 00)
 Blower Drive Shaft And Spring Removed. (WP 0109 00)
 Exhaust Manifolds Removed. (WP 0163 00)
 Marine Gear Oil Cooler Removed. (TM 55-1945-205-24-1-3)
 Fuel Cooler Removed. (WP 0081 00)
 Air Box Covers Removed. (WP 0035 00)
 Air Box Drains Removed. (WP 0036 00)
 Starting Motor Removed.(WP 0170 00)
 Lube Oil Dipstick Tube Assembly Removed. (WP 0130 00)
 Overspeed Governor Removed. (WP 0175 00)
 Marine Gear Oil Cooler Mounting Bracket Removed. (WP 0164 00)
 Lube Oil Cooler Removed. (WP 0128 00)
 Engine Installed On Stand. (WP 0032 00)
 Electrical System Hour Meter Removed. (WP 0167 00)
 Electrical System Hour Meter Bracket Removed. (WP 0168 00)
 Raw Water Pump Removed. (WP 0160 00)
 Electronic Governor Magnetic Pick-Up Removed. (WP 0100 00)
 Oil Pan Removed (WP 0127 00)
 Flywheel Removed. (WP 0069 00)

REMOVE FLYWHEEL HOUSING

WARNING

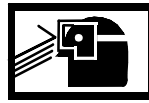
HEAVY PARTS

EYE PROTECTION

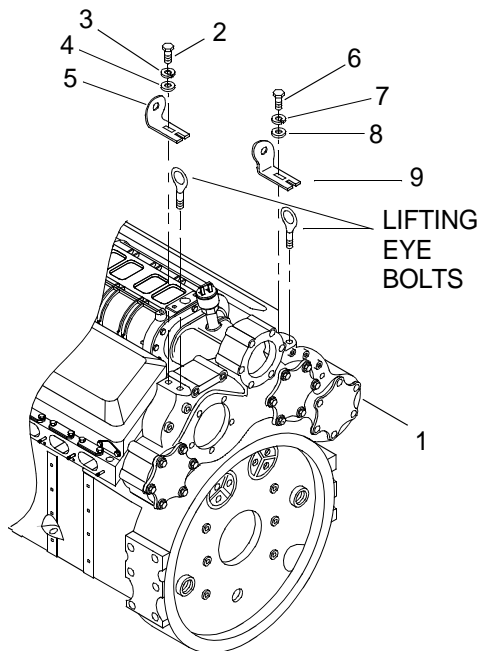
1. Install two lifting eye bolts in flywheel housing (1).



WARNING**HEAVY OBJECTS**

2. Support flywheel housing (1) with a crane, slings and shackles from lifting eye bolts.

NOTE

Do not reuse the old cap screws that secure the flywheel housing to the engine block in this task, tag and mark all screws and bolts throughout this task so that they may be matched with new cap screws to be installed in their proper location.

3. Remove two cap screws (2), lock washers (3), flat washers (4) and left bank bracket (5).
4. Remove two cap screws (6), lock washers (7), flat washers (8) and right bank bracket (9).
5. Remove six cap screws (10) and washers (11) from flywheel housing (1).

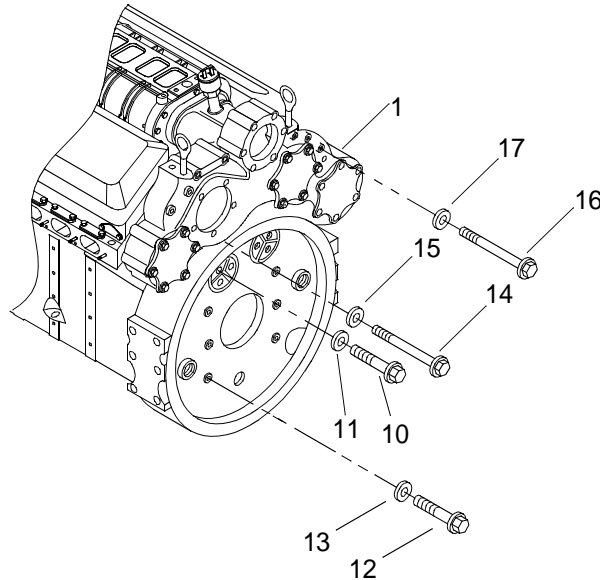

6. Remove six cap screws (12) and lock washers (13) from flywheel housing (1).
7. Remove four cap screws (14) and washers (15) from flywheel housing (1).
8. Remove three cap screws (16) and washers (17) from flywheel housing (1).

9. Remove five cap screws (18) and lock washers (19) from access cover (20).

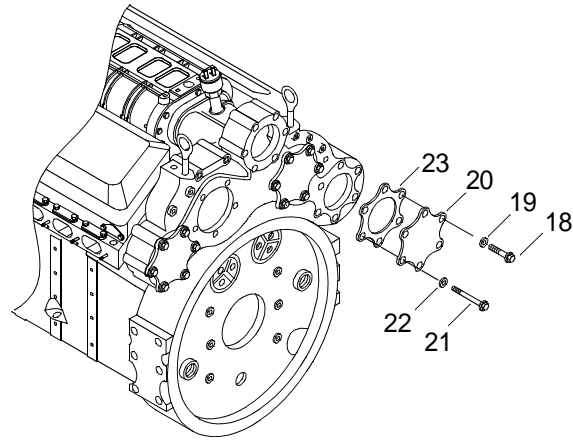

10. Remove cap screw (21) and copper washer (22).
11. Remove access cover (20).
12. Remove gasket (23) and discard.
13. Remove three hex nuts (24), lock washers (25), cap screws (26) and washers (27) from access cover (28).

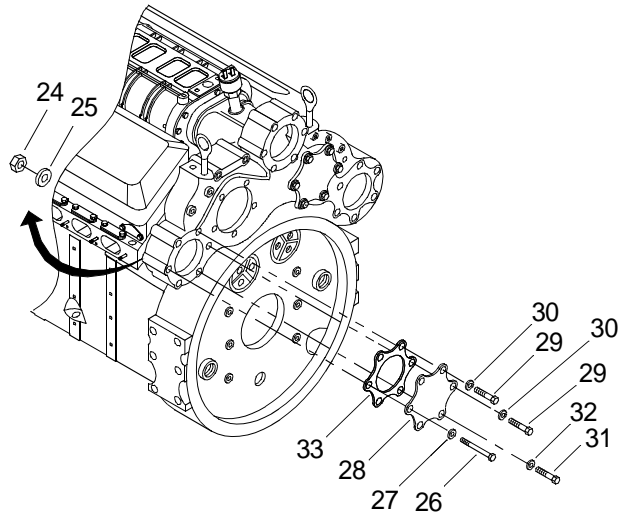

14. Remove two cap screws (29) and lock washers (30).
15. Remove cap screw (31) and washer (32).
16. Remove access cover (28).
17. Remove gasket (33) and discard.

18. Remove two cap screws (34) and lock washers (35) from access cover (36).

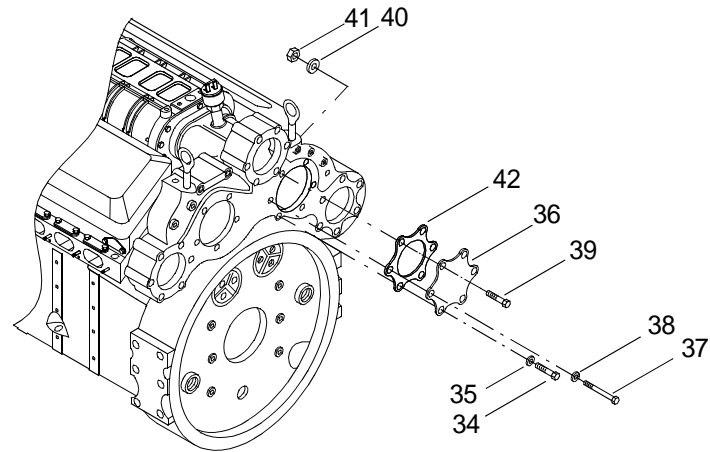

19. Remove three cap screws (37) and lock washers (38) from access plate (36).

20. Remove cap screw (39), copper washer (40) and hex nut (41).

21. Remove access plate (36).

22. Remove gasket (42) and discard.

23. Remove two cap screws (43) and lock washers (44).

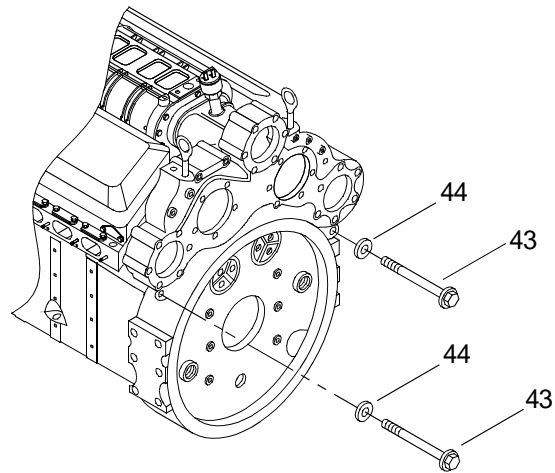

24. Remove cap screw (45) and washer (46) from air box drain retaining clip (47).

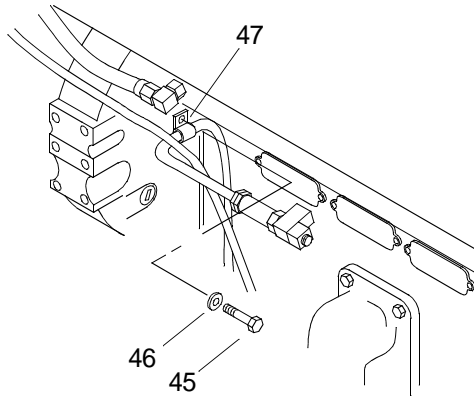

CAUTION

The screw inside the access hole must be removed. Failure to remove the cap screw will result in the flywheel housing being cracked and rendered unserviceable.

25. Remove cap screw (48) from access hole.

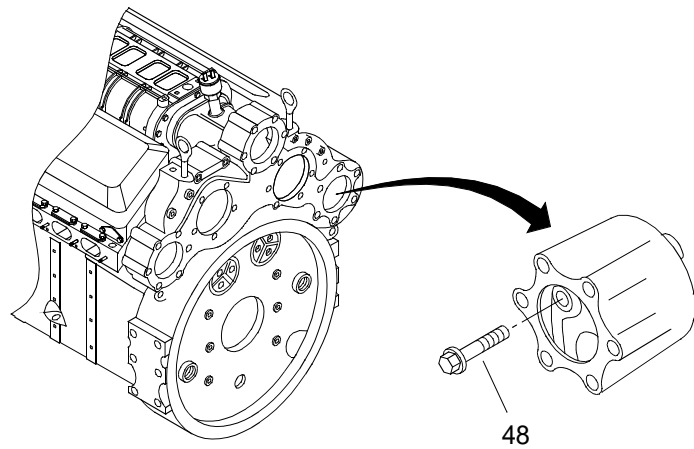

26. Install four aligning studs into the engine block (49).

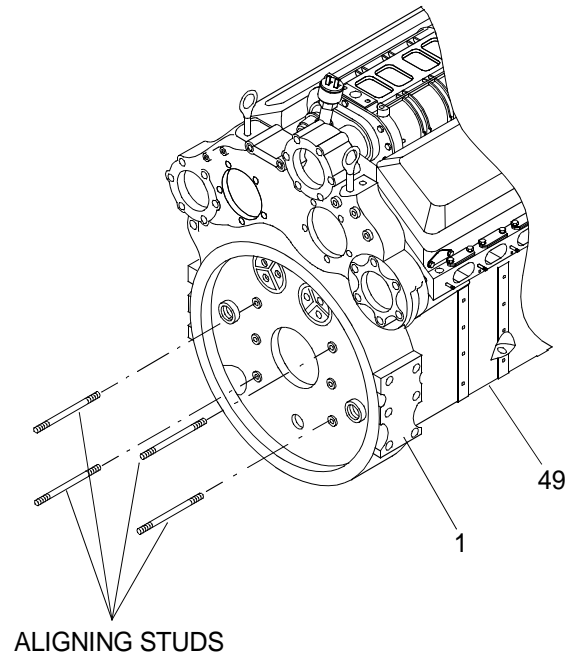

WARNING



HEAVY PARTS

27. Using slings, shackles and crane, remove flywheel housing (1) from the back end of engine (49).

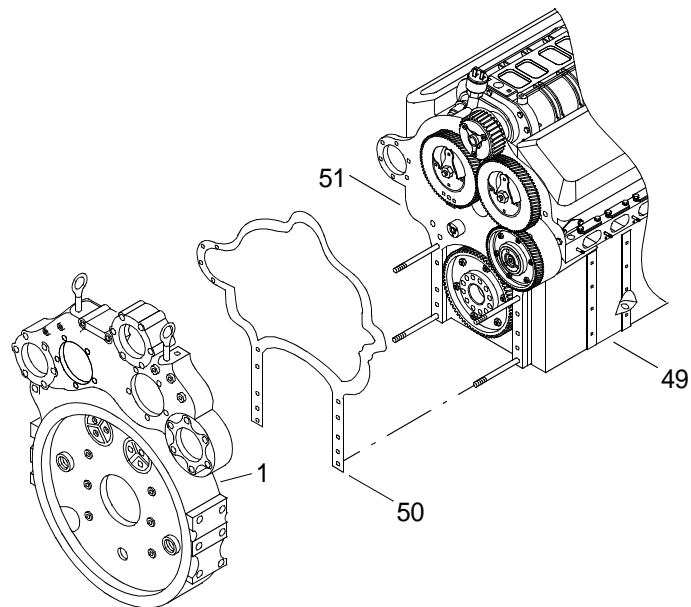

WARNING

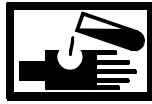
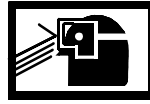
**CHEMICAL****EYE PROTECTION**

28. Remove gasket (50) from engine rear end plate (51) and discard.

WARNING

**EYE PROTECTION**

29. Using a putty knife, clean gasket residue from rear end plate (51) and flywheel housing (1).

30. Remove plugs (52 and 53) from flywheel housing (1).

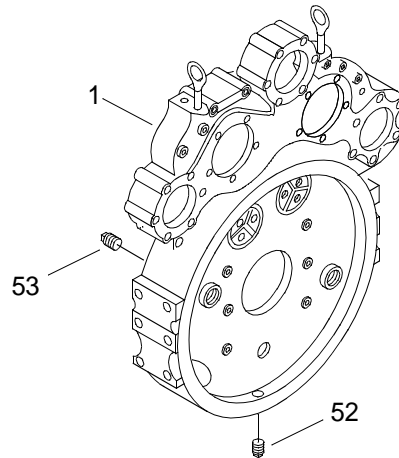

31. Remove slings and shackles from flywheel housing (1).

32. Remove rear crankshaft oil seal. (WP 0061 00)

33. Remove lifting eye bolts from flywheel housing (1).

34. Discard flywheel housing (1).

INSTALL FLYWHEEL HOUSING

WARNING

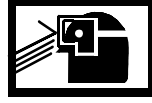
**CHEMICAL****EYE PROTECTION**

CAUTION

Crankshaft must be clean and smooth. Failure to follow procedures can cause damage to oil seal lip.

NOTE

Polishing motion should be clockwise around end of crankshaft.

1. Polish end of crankshaft (54) with abrasive cloth wet with engine lubricating oil.

WARNING

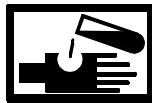
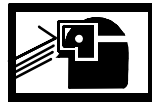
**CHEMICAL****EYE PROTECTION**

2. Lubricate gear train teeth (55) with engine lubricating oil.

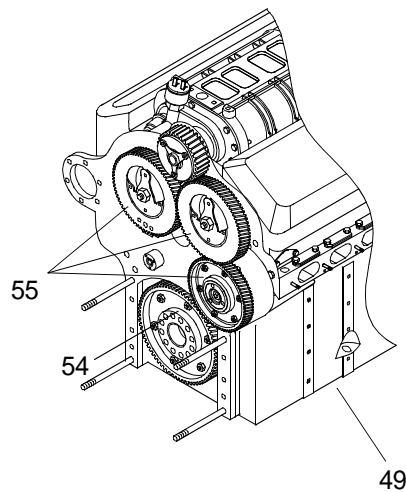

3. Install new crankshaft rear oil seal. (WP 0061 00)

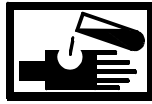
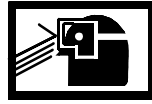
WARNING**CHEMICAL****EYE PROTECTION**

4. Coat threads on pipe plugs (52 and 53) with pipe sealing compound.

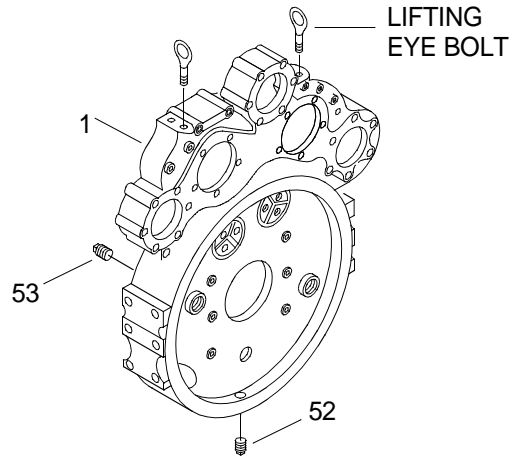

5. Install pipe plugs (52 and 53) in flywheel housing (1).
6. Install two lifting eye bolts on new flywheel housing (1).

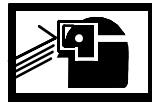
WARNING**CHEMICAL****EYE PROTECTION**

7. Apply ultra blue sealing compound to seal surface of engine block end plate (51).

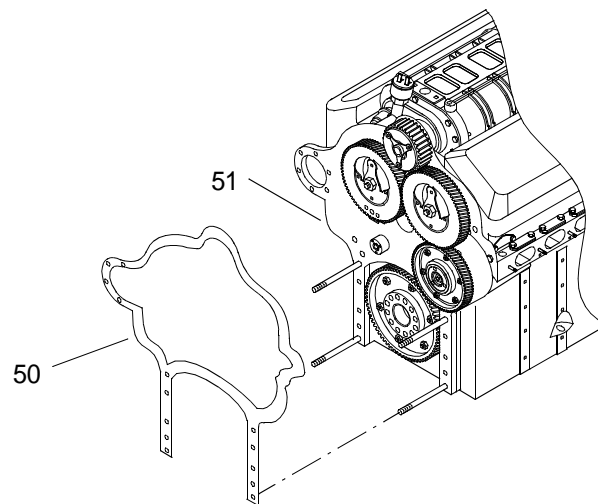

8. Install new gasket (50) on engine block end plate (51).

WARNING

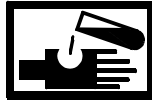
**CHEMICAL****EYE PROTECTION**

9. Apply ultra blue sealing compound to gasket (50).

WARNING

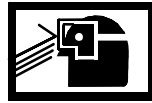
**CHEMICAL****EYE PROTECTION**

10. Coat the lip of the crankshaft oil seal with engine lubricating oil.
11. Attach slings and shackles to lifting eye bolts.

WARNING

**HEAVY PARTS**

12. Using crane, slings and shackles, install new flywheel housing (1) over aligning studs on back of engine (49) and crankshaft (54).

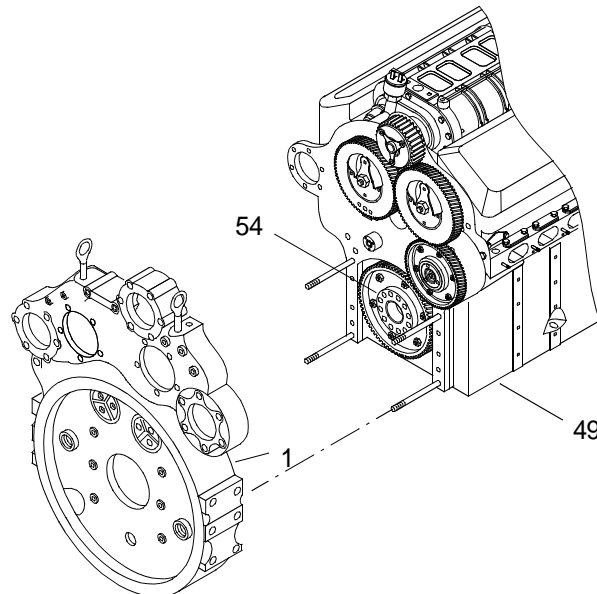

13. Install new cap screw (48) into access hole.

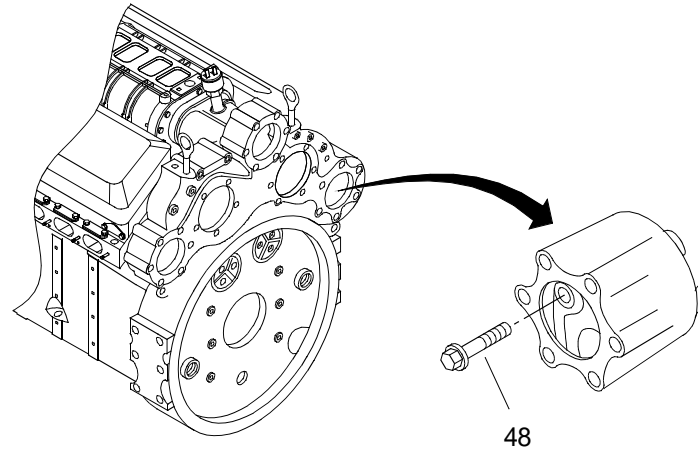

14. Install cap screw (45) and washer (46) through air box drain retaining clip (47).

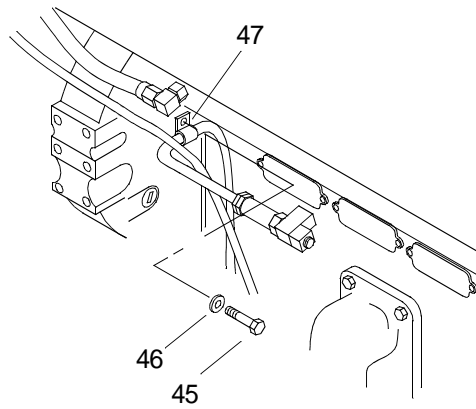

15. Install two new cap screws (43) and lock washers (44) into flywheel housing (1).

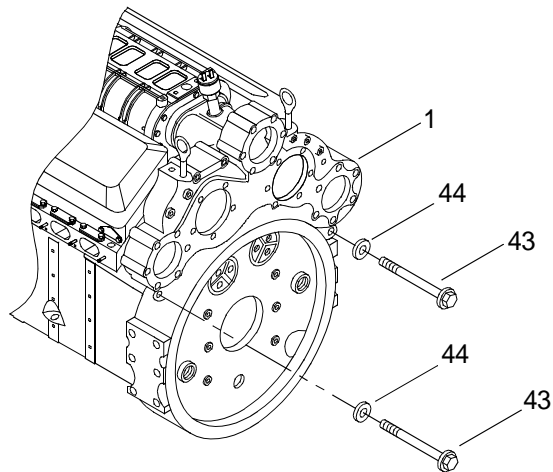

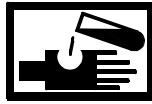
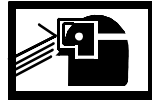
WARNING**CHEMICAL****EYE PROTECTION**

16. Apply ultra blue sealing compound to new gasket (42).

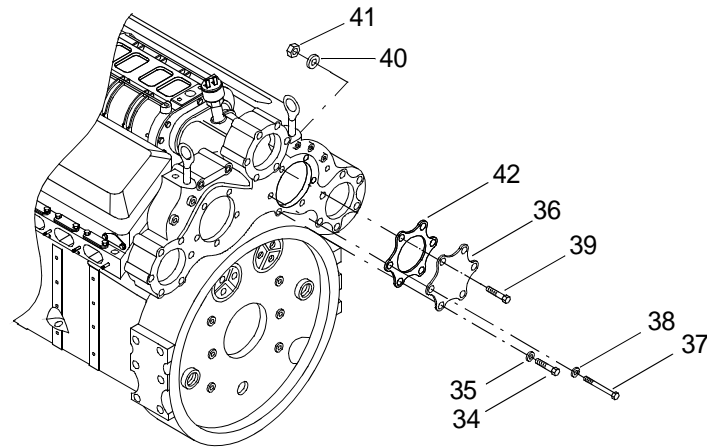

17. Install new gasket (42) on flywheel housing (1).
18. Install access plate (36) on flywheel housing (1).
19. Install cap screw (39) through access cover (36), flywheel housing (1), copper washer (40) into hex nut (41).
20. Install three cap screws (37) and lock washers (38) through access plate (36) and into flywheel housing (1).
21. Install two cap screws (34) and lock washers (35) through access plate (36) and into flywheel housing (1).

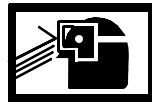
WARNING**CHEMICAL****EYE PROTECTION**

22. Apply ultra blue sealing compound to flywheel housing (1) and access plate (28).

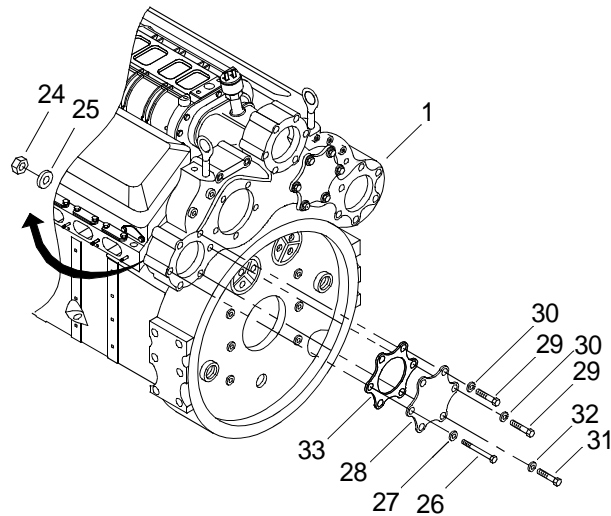

23. Install new gasket (33) on flywheel housing (1).
24. Install cap screws (31) and lock washers (32) through access cover (28) and into flywheel housing (1).
25. Install two cap screws (29) and lock washers (30) through access cover (28) and into flywheel housing (1).
26. Install three cap screws (26), copper washers (27), lock washers (25) and hex nuts (24) through access cover (28) and into flywheel housing (1).
27. Install four new cap screws (14) and lock washers (15) into flywheel housing (1).

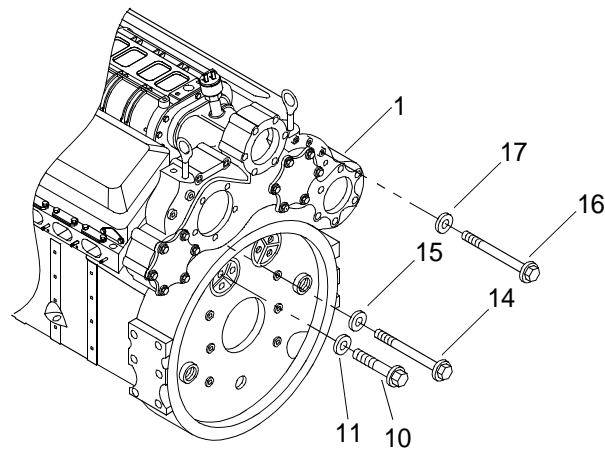

28. Install three new cap screws (16) and lock washers (17) into flywheel housing (1).

WARNING

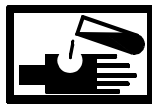

CHEMICAL

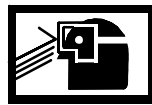

EYE PROTECTION

29. Coat six new cap screws (10) with sealing compound.

30. Install six cap screws (10) and lock washers (11) into flywheel housing (1).

31. Remove slings, shackles, two lifting eye bolts and four aligning studs.

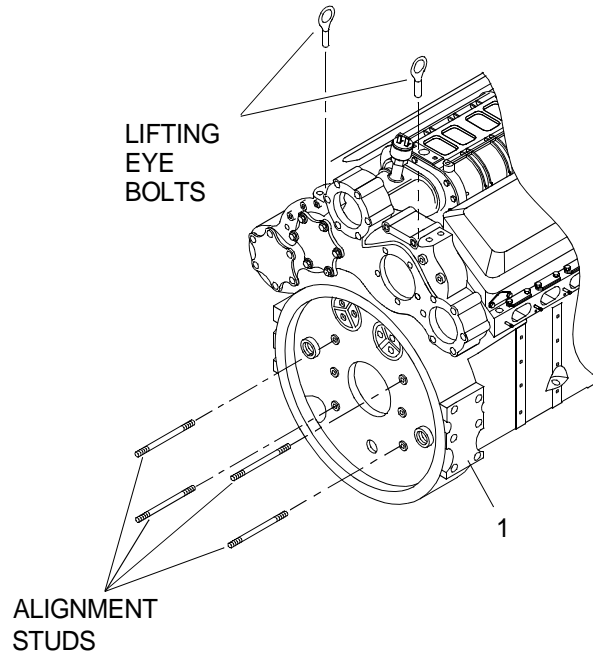

32. Install six new cap screws (12) and lock washers (13) into flywheel housing (1).

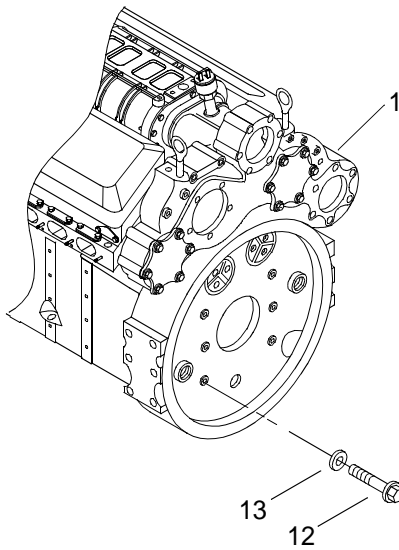

33. Install two cap screws (2), lock washers (3), flat washers (4) and left bank bracket (5) on flywheel housing (1).

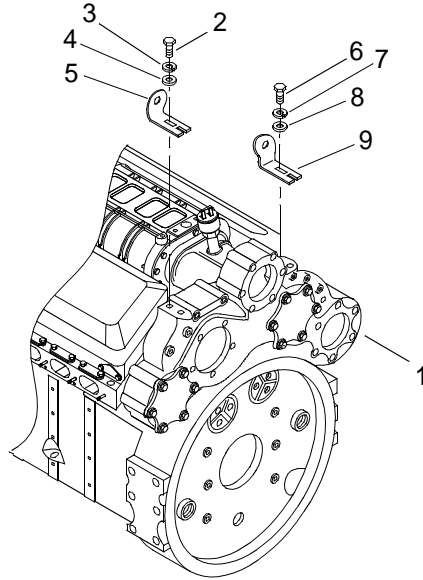

34. Install two cap screws (6), lock washers (7), flat washers (8) and right bank bracket (9) on flywheel housing (1).

NOTE

The tightening sequence is different from the torquing sequence. The two different sequences must be followed for the flywheel housing to align properly.

35. Using flywheel housing tightening sequence diagram, snug all mounting bolts in the specified order.

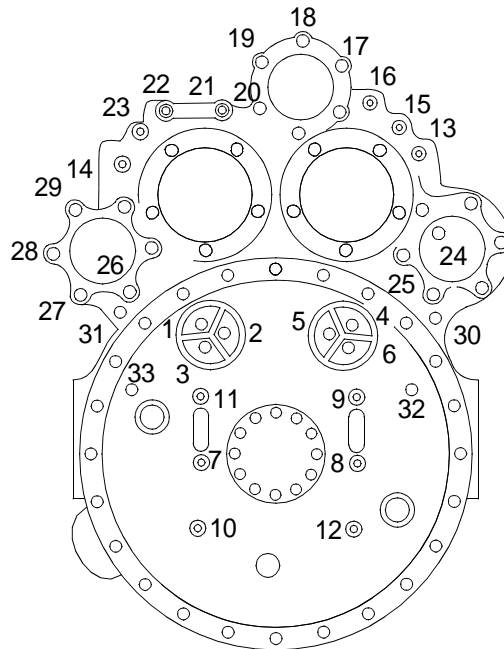

FLYWHEEL TIGHTENING
SEQUENCE DIAGRAM

NOTE

During the following procedures, use of a torque sequence diagram shall be used for torque of cap screws 1-33.

36. Using torque wrench, torque the first six cap screws in flywheel housing to 90-100 ft lbs (122-136 N-m).

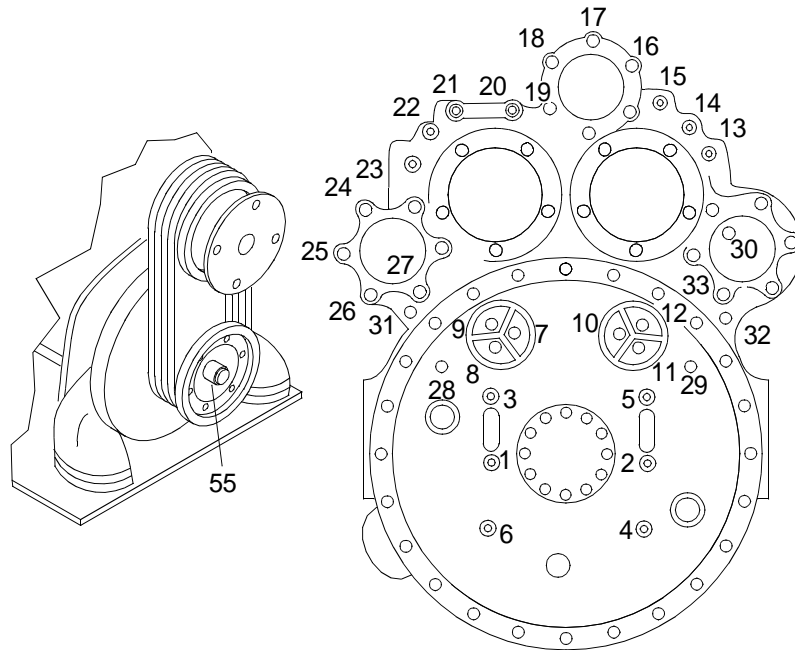

FLYWHEEL HOUSING TORQUE SEQUENCE DIAGRAM

37. Using torque wrench and socket set, torque the seventh through ninth cap screws to 480-540 in. lbs (54-61 N-m).
38. While one soldier turns the crankshaft screw (55) clockwise the other soldier, using torque wrench, socket set and a torque sequence diagram, torques the tenth through twelfth cap screws to 480-540 in. lbs (54-61 N-m).
39. Using torque wrench and socket set, torque the thirteenth through twenty seventh cap screws to 300-360 in. lbs (34-41 N-m).
40. Using torque wrench and socket set, torque cap screw (45) on the right side of the engine to 480-540 in. lbs (54-61 N-m).

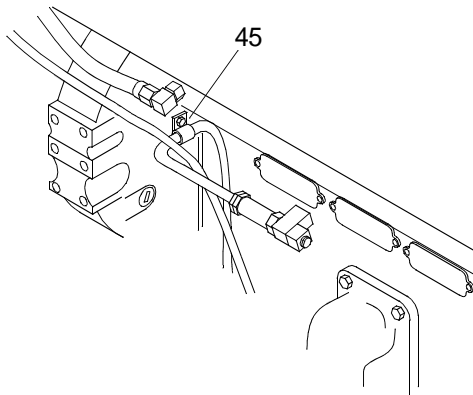

41. Using torque wrench and socket set, torque the twenty eighth cap screw on the flywheel housing to 360-420 in. lbs (41-47 N-m).

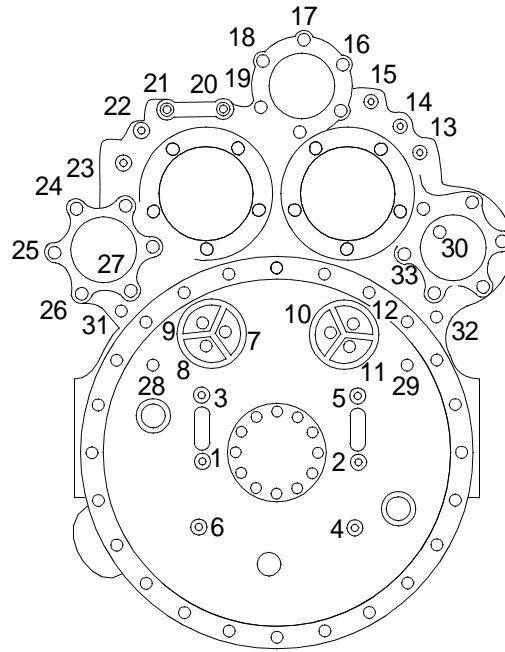

FLYWHEEL HOUSING TORQUE SEQUENCE DIAGRAM

42. Using torque wrench, torque the twenty ninth through thirty-third cap screws to 137-147 ft lbs (186-199 N-m).

WARNING

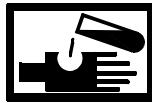

CHEMICAL

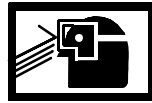

EYE PROTECTION

43. Apply ultra blue sealing compound to flywheel housing (1) and to access cover (20).

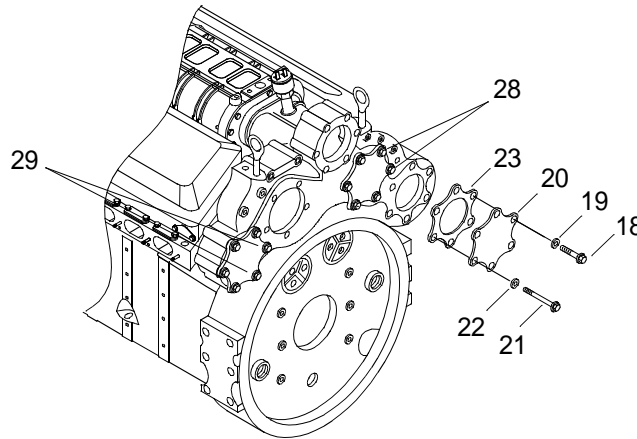

44. Install new gasket (23) on flywheel housing (1).
45. Install access cover (20) on flywheel housing (1).

-
46. Install cap screw (21) through copper washer (22), access cover (20) and gasket (23).
 47. Install five cap screws (18) and lock washers (19).
 48. Using torque wrench and socket set, torque cap screws (18 and 21) to 300-360 in. lbs (34-41 N-m).
 49. Using torque wrench and socket set, torque cap screws (28 and 29) to 300-360 in. lbs (34-41 N-m).
 50. Install flywheel. (WP 0069 00)
 51. Install oil pan. (WP 0127 00)
 52. Install electronic governor magnetic pick-up. (WP 0100 00)
 53. Install raw water pump. (WP 0160 00)
 54. Install electrical system hour meter bracket. (WP 0168 00)
 55. Install electrical system hour meter. (WP 0167 00)
 56. Remove from stand. (WP 0032 00)
 57. Install lube oil cooler. (WP 0128 00)
 58. Install marine gear oil cooler mounting bracket. (WP 0164 00)
 59. Install overspeed governor. (WP 0175 00)
 60. Install lube oil dipstick tube assembly. (WP 0130 00)
 61. Install starting motor.(WP 0170 00)
 62. Install air box drains. (WP 0036 00)
 63. Install air box covers. (WP 0035 00)
 64. Install fuel cooler. (WP 0081 00)
 65. Install marine gear oil cooler. (TM 55-1945-205-24-1-3)
 66. Install exhaust manifolds. (WP 0163 00)
 67. Install blower driveshaft and spring. (WP 0109 00)
 68. Install turbochargers. (WP 0114 00)
 69. Install air inlet collector assembly. (WP 0104 00)
 70. Install crankcase breather limiter. (WP 0106 00)

END OF WORK PACKAGE

**GENERAL SUPPORT MAINTENANCE
CAUSEWAY FERRY
PISTON AND LINER ASSEMBLY
REMOVAL AND INSTALLATION**

INITIAL SETUP:**Tools**

Tool Kit, General Mechanic's
(Item 130, WP 0188 00)
Liner Puller, (Item 78, WP 0188 00)
Wrench, Torque (0-175 ft lbs)
(Item 138, WP 0188 00)
Gloves, Chemical (Item 52, WP 0188 00)
Goggles, Industrial (Item 54, WP 0188 00)
Bracket, Mounting (Item 17, WP 0188 00)

Materials/Parts

Gasket
(72582)
NSN 5330-00-911-4628
PN 5117242
Insert, Standard
(72582)
NSN 2815-01-058-0254
PN 5148501
Seal
(72582)
NSN 5330-01-054-2267
PN 8927189
Cloth, Cleaning (Item 13, WP 0187 00)
Oil, Lubricating, Engine, 30W
(Item 26, WP 0187 00)

Personnel Required

Engineer 88L (2)

Equipment Condition

Crankcase Breather Limiter Assembly Removed.
(WP 0106 00)
Air Inlet Collector Assembly Removed.
(WP 0104 00)
Turbocharger Removed. (WP 0114 00)
Exhaust Manifold Removed. (WP 0163 00)
Marine Gear Oil Cooler Removed.
(TM 55-1945-205-24-1-3)

Equipment Condition (Cont'd)

Fuel Cooler Removed. (WP 0081 00)
Air Box Covers Removed. (WP 0035 00)
Air Box Drains Removed. (WP 0036 00)
Starting Motor Removed. (WP 0170 00)
Lube Oil Dipstick Tube Assembly Removed.
(WP 0130 00)
Marine Gear Oil Cooler Mounting Bracket
Removed. (WP 0164 00)
Lube Oil Cooler Removed. (WP 0128 00)
Engine Installed On Stand. (WP 0032 00)
Water Pump Bypass Tubes Removed.
(WP 0148 00)
Cylinder Head Poppet Valve Rocker Arm Covers
Removed. (WP 0043 00)
Cylinder Head Poppet Valve Rocker Arms
Removed. (WP 0048 00)
Overspeed Governor Removed. (WP 0175 00)
Electronic Governor Actuator Rod Removed.
(WP 0097 00)
Governor Actuator Removed. (WP 0098 00)
Fuel Pump Removed. (WP 0094 00)
Air Intake Housing Removed. (WP 0103 00)
Blower Drive Shaft Removed. (WP 0109 00)
Blower Removed. (WP 0110 00)
Heat Exchanger Removed. (WP 0138 00)
Starboard Thermostat Housing Removed.
(WP 0144 00)
Port Thermostat Housing Removed. (WP 0145 00)
Fuel Injector Control Tube And Lever Removed.
(WP 0086 00)
Cylinder Heads Removed. (WP 0046 00)
Lube Oil Pan Removed. (WP 0127 00)
Lube Oil Pressure Regulator Valve Removed.
(WP 0123 00)
Lube Oil Pressure Relief Valve Removed.
(WP 0125 00)

REMOVE PISTON AND LINER ASSEMBLY
NOTE

Piston and liner assembly components should be matched and marked during removal to ensure that they are installed in the same position.

1. Rotate engine (1) so bottom side is up.

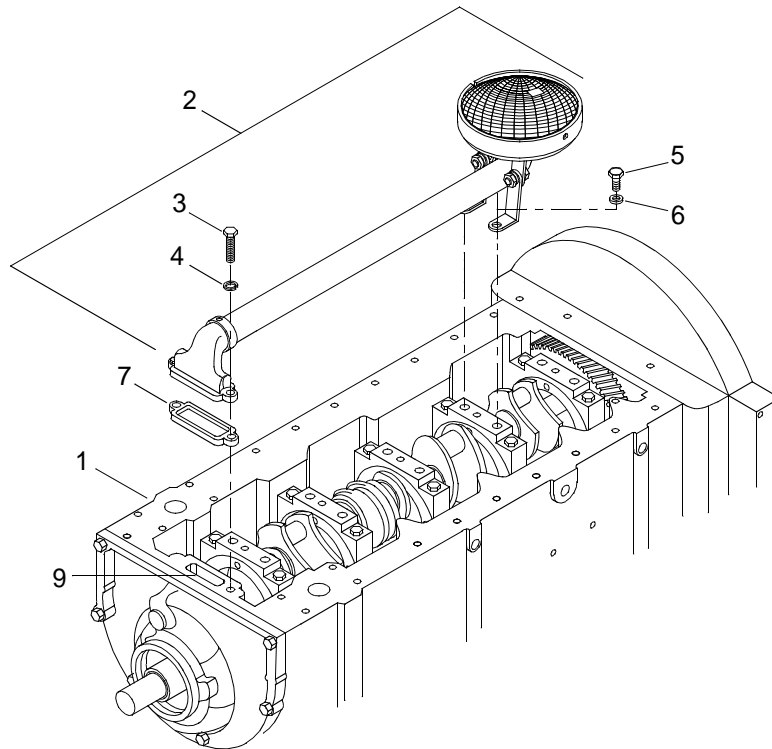

2. Remove the oil distribution inlet tube and screen assembly (2).
 - a. Remove two cap screws (3) and lock washers (4) from oil distribution inlet tube and screen assembly (2).
 - b. Remove two cap screws (5) and lock washers (6) from oil distribution inlet tube and screen assembly (2).
 - c. Remove oil distribution inlet tube and screen (2) as an assembly.
 - d. Remove and discard gasket (7).
3. Rotate engine (1) so the top side is up.
4. Lower the piston (8) to just above the air inlet ports (9).

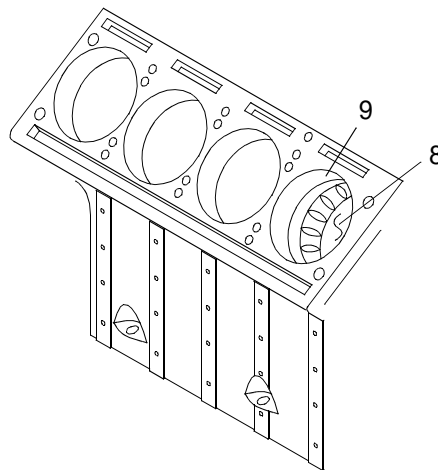

5. Insert liner puller into the cylinder liner air inlet ports (9).

6. Raise the piston (8) until it makes contact with the liner puller tool and pushes the liner puller tool to the top of the air inlet port (9).
7. Rotate engine (1) so bottom side is up.

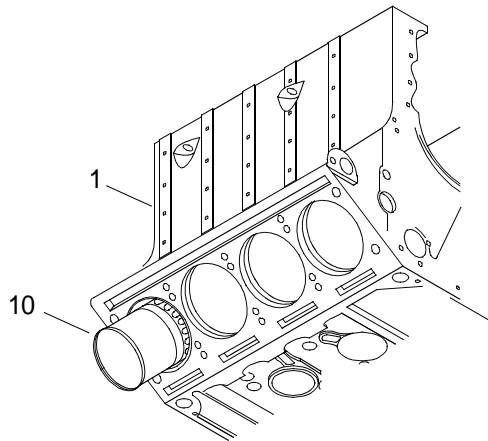

8. Continue the rotation of the crankshaft and push the piston and liner assembly (10) out of the block (1).
9. Remove two rod cap hex nuts (11) connecting rod cap (12) and lower half of bearing (13).

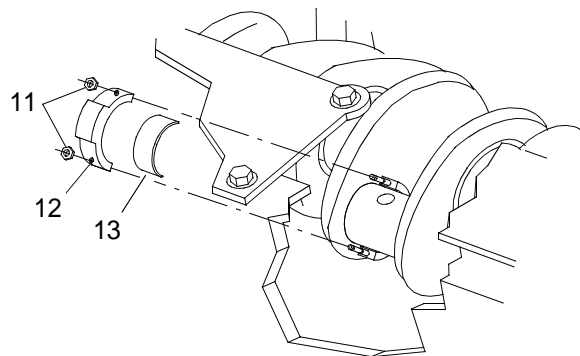

10. Have one soldier rotate the crankshaft and push the piston and liner assembly (10) out of the block (1).

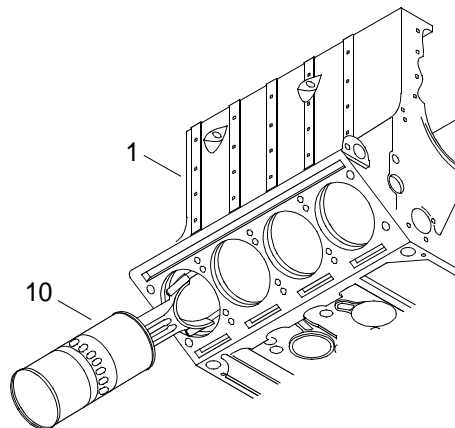

CAUTION

Do not allow the piston to fall out of the cylinder liner. Failure to comply may result in damage to equipment.

If the rings are allowed to expand after being removed from the cylinder liner, they must be replaced.

11. Have the other soldier catch the piston and liner assembly (10).
12. Remove two cylinder liner seal rings (14) from engine block (1) and discard.

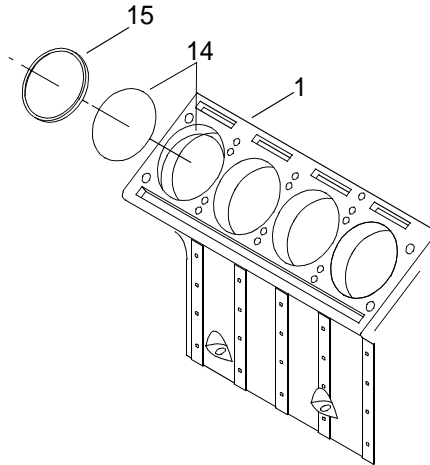

13. Remove liner insert (15) from engine block (1) and discard.
14. Repeat steps 1 thru 13 to remove remaining seven pistons and liner assemblies.

INSTALL PISTON AND LINER ASSEMBLY

1. Install two new cylinder liner seal rings (14) into block (1).

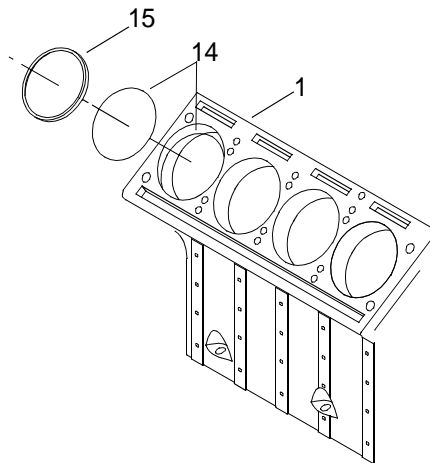

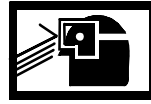
WARNING**CHEMICAL****EYE PROTECTION**

2. Apply lubricating oil to inner surface of the liner seal rings (14).
3. Install new liner insert (15) into counter bore of engine block (1).
4. Push the piston (8) up into the cylinder liner (16) until the compression rings pass the liner ports (9).

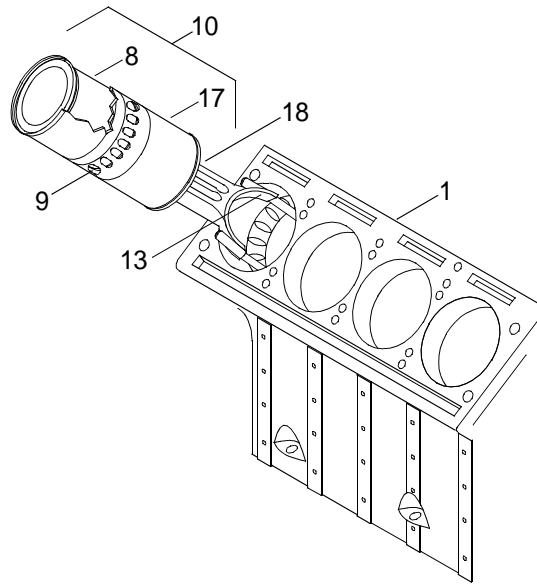
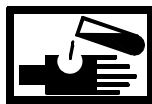
**WARNING****CHEMICAL****EYE PROTECTION**

5. Coat the connecting rod bearings (13) with lubricating oil.

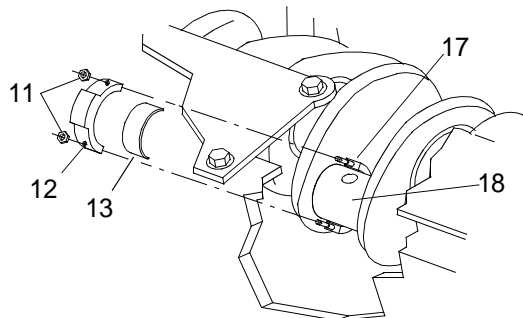

6. Install the upper half of bearing (13) onto connecting rod (17).

7. One engineer inserts the piston and liner assembly (10).
8. Position crankshaft journal (18) at the bottom of its stroke.

WARNING



CHEMICAL



EYE PROTECTION

9. Lubricate crankshaft journal (18) with lubricating oil.
10. The other engineer guides the connecting rod (18) onto the crankshaft journal (17).
11. Install lower half of bearing (13) in connecting rod cap (12).
12. Install connecting rod cap (12) onto connecting rod (17).
13. Install two hex nuts (11).
14. Using torque wrench, torque hex nuts (11) to 70 ft lbs (95 N-m).
15. Install mounting brackets to hold liner into place.
16. Repeat steps 1 thru 14 to install remaining seven piston and liner assemblies.
17. Rotate engine (1) so that bottom is up.
18. Install the oil distribution inlet tube and screen assembly (2).

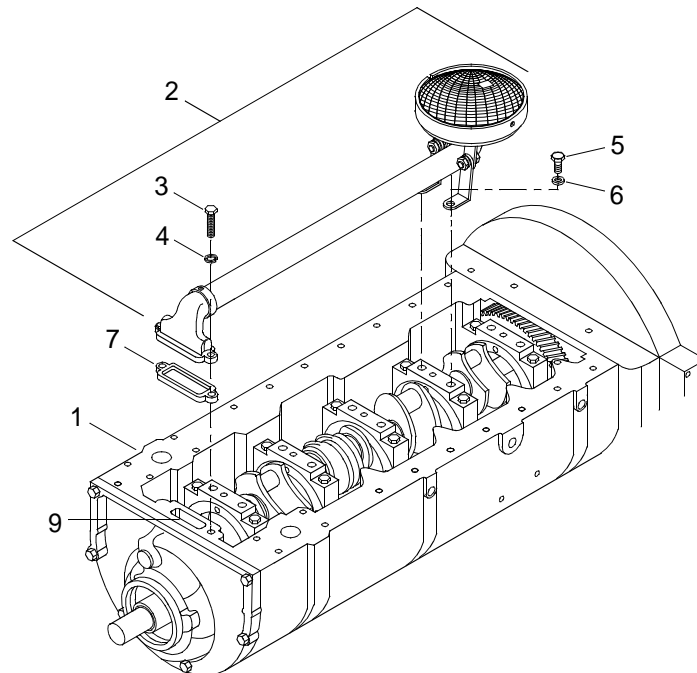

- a. Install new gasket (7).

-
- b. Position oil distribution inlet tube and screen assembly (2) on engine (1).
 - c. Install two lock washers (6) and cap screws (5) in oil distribution inlet tube and screen assembly (2).
 - d. Tighten cap screws (5).
 - e. Install two lock washers (4) and cap screws (3) in oil distribution inlet tube and screen assembly (2).
 - f. Tighten cap screws (3).
19. Install lube oil pressure relief valve. (WP 0125 00)
 20. Install lube oil pressure regulator valve. (WP 0123 00)
 21. Install lube oil pan. (WP 0127 00)
 22. Install cylinder heads. (WP 0046 00)
 23. Install fuel injector control tube and lever. (WP 0086 00)
 24. Install starboard thermostat housing. (WP 0144 00)
 25. Install port thermostat housing. (WP 0145 00)
 26. Install heat exchanger. (WP 0138 00)
 27. Install blower. (WP 0110 00)
 28. Install blower drive shaft. (WP 0109 00)
 29. Install air intake housing. (WP 0103 00)
 30. Install governor actuator. (WP 0098 00)
 31. Install electronic governor actuator rod. (WP 0097 00)
 32. Install overspeed governor. (WP 0175 00)
 33. Install cylinder head poppet valve rocker arms. (WP 0048 00)
 34. Install cylinder head poppet valve rocker arm covers. (WP 0043 00)
 35. Install water pump bypass hose. (WP 0148 00)
 36. Install fuel pump. (WP 0094 00)
 37. Remove engine from stand. (WP 0032 00)
 38. Install lube oil cooler. (WP 0128 00)
 39. Install marine gear oil cooler mounting bracket. (WP 0164 00)
 40. Install lube oil dipstick tube assembly. (WP 0130 00)
 41. Install starting motor. (WP 0170 00)

- 42. Install air box drains. (WP 0036 00)
- 43. Install air box covers. (WP 0035 00)
- 44. Install fuel cooler. (WP 0081 00)
- 45. Install marine gear oil cooler. (TM 55-1945-205-24-1-3)
- 46. Install exhaust manifold. (WP 0163 00)
- 47. Install turbocharger. (WP 0114 00)
- 48. Install air inlet collector assembly. (WP 0104 00)
- 49. Install crankcase breather limiter assembly. (WP 0106 00)

END OF WORK PACKAGE

**GENERAL SUPPORT MAINTENANCE
CAUSEWAY FERRY
PISTON AND CYLINDER LINER
REBUILD**

INITIAL SETUP:**Tools**

Tool Kit, General Mechanic's (Item 130, WP 0188 00)
Blaster, Uneven Surface (Glass Bead) (Item 9, WP 0188 00)
Wrench, Torque (0-175 ft lbs) (Item 138, WP 0188 00)
Vice, Machinist's (Item 133, WP 0188 00)
Caps, Vice Jaw (Item 24, WP 0188 00)
Brush, Wire Scratch (Item 21, WP 0188 00)
Gloves, Chemical (Item 52, WP 0188 00)
Goggles, Industrial (Item 54, WP 0188 00)
Liner Puller, (Item 78, WP 0188 00)
Reconditioning Tool, Piston Ring Groove (Item 103, WP 0188 00)
Gage, Groove (Item 46, WP 0188 00)
Installer, Piston Pin Retainer (Item 72, WP 0188 00)
Tester, Vacuum Gage (Item 125, WP 0188 00)
Body, Cylinder Hone (Item 10, WP 0188 00)
Stone, Abrasive, Cylinder Hone (Item 121, WP 0188 00)
Compressor, Ring (Item 28, WP 0188 00)
Alignment Tool, Piston Pin (Item 07, WP 0188 00)
Gage, Cylinder (Item 44, WP 0188 00)
Setting, Master, Dial Bore Gauge (Item 114, WP 0188 00)
Gage, Master Ring (Item 49, WP 0188 00)
Remover and Replace (Ring Expander) (Item 104, WP 0188 00)
Gage Set, Piston (Item 40, WP 0188 00)
Bracket, Mounting (Hold Down Clamp) (Item 17, WP 0188 00)
Gage, Cylinder (Item 43, WP 0188 00)
Degreaser (Tank, Cleaning) (Item 32, WP 0188 00)

Materials/Parts

Parts Kit, Linear Actuating Cylinder Assembly
(72582)
NSN 3040-01-361-8202
PN 23514258
Qty 8
Cloth, Cleaning (Item 13, WP 0187 00)
Oil, Lubricating, Engine, 10W (Item 25, WP 0187 00)
Cleaning Compound (Item 10, WP 0187 00)
Lumber, Softwood, Dimension (2 in. X 4 in. X 6 ft Min Wooden Blocks) (Item 23, WP 0187 00)
Qty 2

Personnel Required

Engineer 88L (2)

DISASSEMBLE PISTON AND LINER ASSEMBLY

CAUTION

Once the piston has been removed from the liner, if the rings are allowed to expand, they must be replaced. Failure to comply could result in damage to the piston ring grooves.

NOTE

Piston and liner assembly components should be matched and marked during disassembly to ensure that they are assembled in the same order.

This task is typical for the rebuilding of all eight piston and liner assemblies.

1. Slide the piston (1) out through the bottom of the cylinder liner (2).

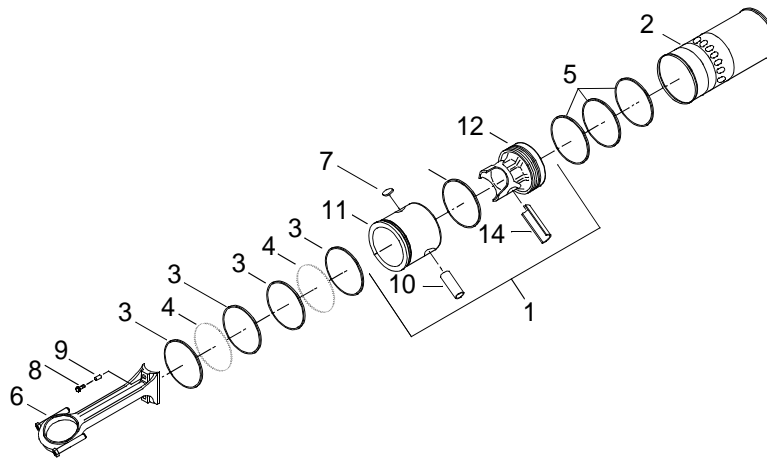

2. Remove the piston rings (3, 4 and 5).
 - a. Secure the connecting rod (6) in a vice equipped with soft vice caps.
 - b. Remove the piston rings (3, 4 and 5) by using ring expander J 8128.
 - c. Discard piston rings (3, 4 and 5).
3. Remove the connecting rod (6).
 - a. Using a narrow chisel or punch, punch a hole through the center of one of the piston pin retainers (7).
 - b. Pry retainer (7) from the piston (1).
 - c. Remove the opposite piston pin retainer (7) in the same manner.
 - d. Discard piston pin retainers (7).
 - e. Remove two screws (8) and spacers (9) securing the connecting rod (6) to the piston pin (10).
 - f. Remove piston (1) from connecting rod (6).

4. Slide the piston pin (10) from the piston (1).

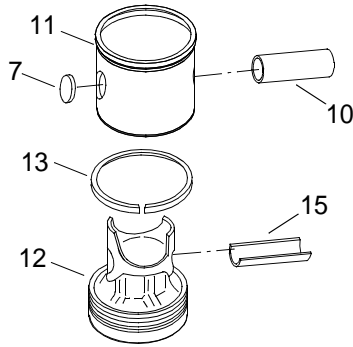

5. Separate the piston skirt (11) from the piston crown (12).
6. Remove the seal ring (13) from the piston crown (12).
7. Discard seal ring (13).
8. Remove the piston pin bushing (14) from piston crown (12).

CLEAN PISTONS

WARNING

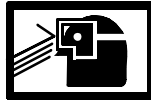

EYE PROTECTION

1. Use a wire brush to clean light carbon from the outside surfaces of the piston crown (12).

WARNING



EYE PROTECTION

2. Using a glass bead blaster, clean heavy carbon deposits from the piston crown (12).

WARNING



CHEMICAL



EYE PROTECTION

3. Using cleaning compound, clean the piston crown (12).
4. Using a reconditioning tool, clean the compression ring grooves.

WARNING



CHEMICAL

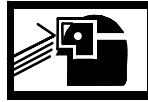

EYE PROTECTION

5. Use compressed air to dry piston crown.

WARNING



CHEMICAL

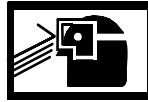

EYE PROTECTION

CAUTION

Do not use glass bead blaster to clean piston skirt. Failure to comply could result in damage to the equipment.

6. Using cleaner, clean the piston skirt (11).

WARNING



CHEMICAL



EYE PROTECTION

7. Using cleaning compound, clean the remaining parts.

WARNING



CHEMICAL



EYE PROTECTION

8. Place the liner (2) in a metal basket and immerse in a tank of cleaning compound.

WARNING



EYE PROTECTION

9. Dry liner using compressed air.

INSPECT PISTONS**NOTE**

The piston crown, bearing and pin must be replaced as an assembly. The piston skirt may be replaced separately.

1. Inspect the piston crown (12) and piston skirt (11) for scoring, heat damage and excessive wear. Replace damaged parts.
2. Inspect the ring groove lands and steps for any evidence of overheating or cracking. Replace damaged parts.
3. Check the tapered fire ring groove width in the piston crown (12) with groove gage.

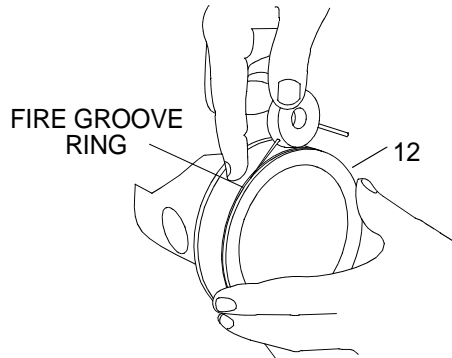

- a. Slide the NO-GO wire 0.106 in. dia all the way around the fire ring groove. If the wire is below or flush at any one area, the piston crown (12) must be replaced.
 - b. Slide the GO wire 0.100 in. dia all the way around the fire ring groove. The GO wire should be flush or protrude slightly.
4. Check the head of the piston crown (12) for small cracks using the fluorescent magnetic particle method. Replace piston crown (12) as necessary.
 5. Measure the piston crown (12) as follows.
 - a. Measure the saddle to crown distance. It must be a minimum of 2.7025 in. (6.86435 cm) and a maximum of 2.7095 in. (6.88213 cm) Replace damaged parts.
 - b. Measure the diameter at the top. It should measure a minimum of 4.8104 in. (12.21841 cm) and a maximum of 4.8134 in. (12.22603 cm) Replace damaged parts.
 - c. Measure the diameter below both compression rings. It should measure a minimum of 4.823 in. (12.22603 cm) and a maximum of 4.8303 in. (12.26896 cm) Replace damaged parts.
 - d. Measure the diameter above and below the seal ring groove. It should measure a minimum of 4.4650 in. (11.3411 cm) and a maximum 4.4750 in. (11.3665 cm) Replace damaged parts.
 - e. Measure the diameter above and below the bearing saddle. It should measure a minimum of 3.2360 in. (8.21944 cm) and a maximum of 3.2370 in. (8.22198 cm) Replace damaged parts.
 6. Measure the piston skirt (11) as follows.

- a. Measure the diameter including the tin. It should measure a minimum of 4.8318 in. (12.27277 cm) and a maximum of 4.8340 in. (12.27836 cm) Replace damaged parts.
 - b. Measure the diameter of the seal ring bore. It should measure a minimum of 4.5000 in. (11.4300 cm) and a maximum of 4.5030 in. (11.43762 cm) Replace damaged parts.
 - c. Measure the inside diameter of the piston pin bore. It should be minimum of 1.5025 in. (3.81635 cm) and a maximum of 1.5035 in. (3.81889 cm) Replace damaged parts.
7. Inspect liners (2) for cracks, excessive scoring or flange irregularities. If found, replace the piston liners (2).
 8. Inspect the liners (2) for poor contact on the outer surfaces.

NOTE

Fretting is a build-up of block material on the outside surface of the liner from movement of the liner in the block during operation.

- a. Check outside diameter for fretting below the ports. If found, a coarse stone or file may be used to remove fretting.

WARNING



CHEMICAL

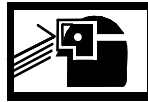

EYE PROTECTION

- b. Check the outside diameter of liners (2) for corrosion. If found, a wire brush and cleaner HA-777 can be used to remove the corrosion.

HONE CYLINDER LINERS

CAUTION

Hone old cylinder liners before reuse. Failure to comply will result in damage to pistons, piston rings or increased time to seat the piston rings.

The engine will need to be completely disassembled and thoroughly cleaned after honing. Failure to comply may result in damage to engine.

If a new cylinder liner is to be used, do not hone the new liner if it has a factory honed surface.

NOTE

During honing process, support the liner firmly being careful not to squeeze it out of round. Using the engine block to support the liner is an accepted method of support, during the honing process.

1. Secure the liners (2) in a suitable fixture.

WARNING

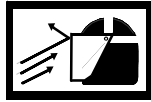

FLYING PARTICLES

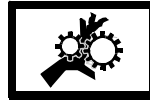

MOVING PARTS

2. Work body with stones, cylinder hone abrasive and cylinder hone up and down the full length of the liner (2), at 300 to 400 RPM's.

NOTE

Upon completion of honing the cylinder, liner should have a criss-cross pattern of marks at a 45° axis.

3. Measure the cylinder liners (2) using a gage, cylinder, setting master, dial bore gage and master ring gage.

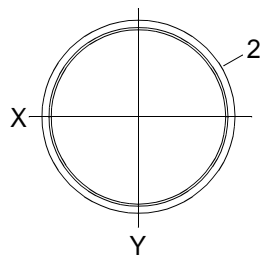

X - LONGITUDUNAL AXIS
(LENGTHWISE OF ENGINE)

Y - TRANSVERSE AXIS
(CROSSWISE OF ENGINE)

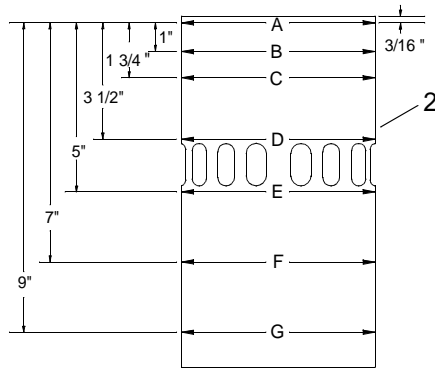

MEASURE INSIDE
DIAMETER OF
LINER AT PLACES
A, B, C, D, E, F
AND G ON "X" AND
"Y" AXES.

- a. Measure the inside bore of the cylinder liner at (A, B, C, D, E, F and G) on both the (X) and (Y) axis.

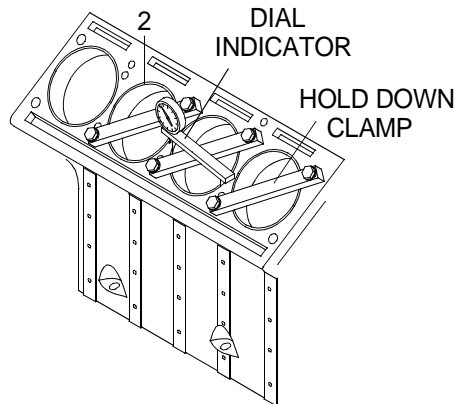

-
- {1} Calculate the general inside diameter of the liner, it should measure a minimum of 4.8390 in. (12.29106 cm) and a maximum of 4.8415 in. (12.29741 cm). Replace damaged parts.
- {2} Calculate out of round of a new cylinder liner, it must not exceed 0.0020 in. (0.00508 cm). Replace damaged parts.
- {3} Calculate out of round of a used cylinder liner, it must not exceed 0.0025 in. (0.00635 cm). Replace damaged parts.
- {4} Calculate taper of a new cylinder liner, it must not exceed 0.0015 in. (0.00381 cm). Replace damaged parts.
- {5} Calculate taper of a used cylinder liner, it must not exceed 0.0025 in. (0.00635 cm) Replace damaged parts.
- b. Measure the outside diameter of the cylinder liner upper surface, not to exceed 5.3577 in. (13.60855 cm) minimum and a maximum of 5.3595 in. (13.61313 cm). Replace damaged parts.
- c. Measure the outside diameter of the cylinder liner seal ring surface, not to exceed a minimum of 5.3347 in. (13.55013 cm) and a maximum of 5.3365 in. (13.55471 cm). Replace damaged parts.
- d. Measure the outside diameter of the cylinder liner lower surface, not to exceed a minimum of 5.2142 in. (13.24406 cm) and a maximum of 5.2160 in. (13.24864 cm). Replace damaged parts.
- e. Measure the flange depth below the top surface of the block.
- {1} Install liner insert (15) previously marked for that cylinder bore and liner (2) back in the original cylinder bore it came from.

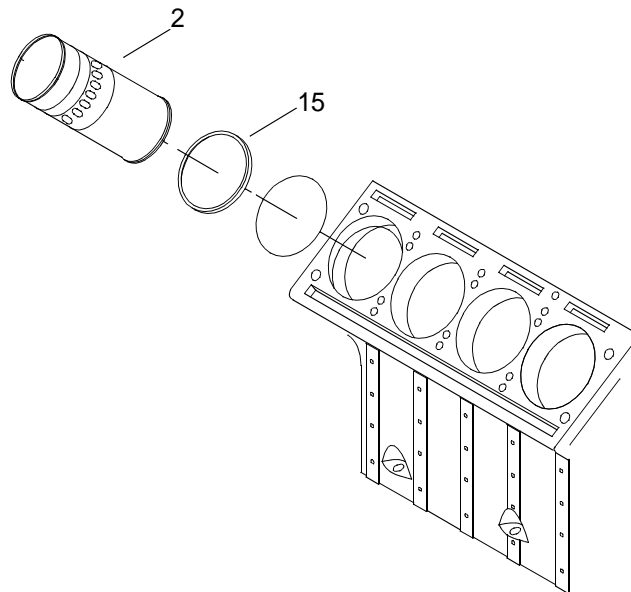
**NOTE**

Do not use excessive force to install the liner. The liner should slide smoothly into place by hand.

- {2} Push the liner insert (15) into the cylinder bore until it rests on the insert.

{3} Clamp the liner into place with hold down clamp.

{4} Measure the distance from the top of the block to the top of the cylinder liner (15). The liner (15) must be a minimum of 0.04187 in. (0.010634 cm) to a maximum of 0.0482 in. (0.12242 cm)

{5} Remove the clamp.

{6} Remove the liner (15).

- f. Calculate the variation in depth between adjacent liners. There can not be more than 0.0015 in. (0.00381 cm) between adjacent liners.

ASSEMBLE PISTON WITH SEAL RING

NOTE

On new bearings, there is a 0.0005 in. (0.00127 cm) to 0.0105 in. (0.02667 cm) clearance between the edge of the bearing and the groove in the piston crown (9). The bearings should slide in without force.

1. Install the piston pin bushing (14) into the piston crown (12).

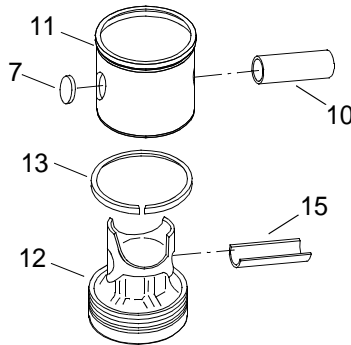

2. Install the new ring (13) into the counterbore of skirt (11).
3. Verify the end gap is a minimum of 0.0020 in. (0.00508 cm) and a maximum of 0.0170 in. (0.04318 cm).

WARNING

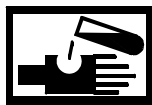

CHEMICAL



EYE PROTECTION

4. Coat the ring (13) with engine oil.
5. Install ring (13) on the piston crown (12) and ensure that it spins freely.
6. Measure the side clearance to be no less than 0.0005 in. (0.00127 cm) and no more than 0.0030 in. (0.00762 cm).
7. Push the piston skirt (11) over the ring (13) on the piston crown (12).

NOTE

The piston crown should spin freely.

8. Hold the piston assembly (1) in one hand by the piston skirt (11).
9. Install the piston pin (10).

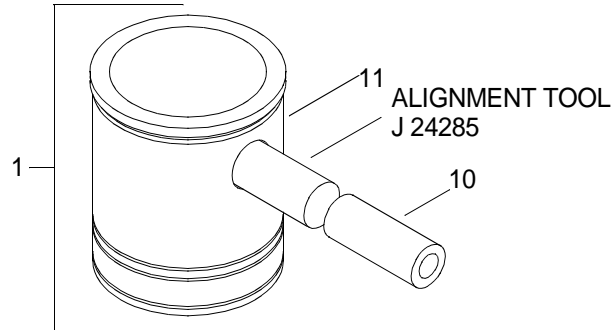

- a. Using aligning tool, align the piston crown (12), piston skirt (11) and the bearing (14).

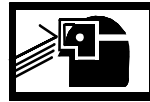
WARNING**CHEMICAL****EYE PROTECTION**

- b. Lubricate piston pin (10) with engine oil.

WARNING**CHEMICAL****EYE PROTECTION**

- c. Press piston pin (10) into piston assembly (1) with threaded holes pointing down.

FIT AND MEASURE PISTON RINGS AND PISTONS

1. Fit the new piston rings.
 - a. Insert one of the rings (3 or 5) at a time into the cylinder liner (2) far enough down to be within normal ring travel.

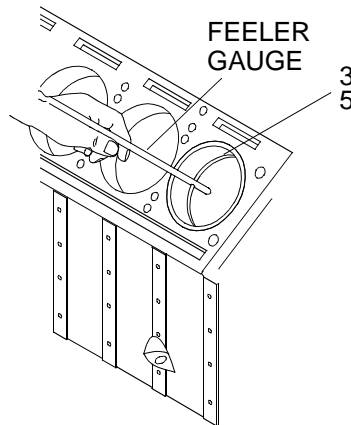

- b. Using the skirt of the piston (1), push the ring down slightly, to level the ring with the top of the liner.
- c. Measure the gap between the ends of the ring as follows:
 - {1} Measure the new top ring (5), it should have an end gap of no less than 0.0250 in. (0.0635 cm) and not more than 0.0450 in. (0.1143 cm).
 - {2} Measure the new middle and lower rings (5), they should have an end gap not less than 0.0250 in. (0.0635 cm) and not more than 0.0450 in. (0.1143 cm).
 - {3} Measure the new top rings (3), they should have an end gap of no less than 0.0070 in. (0.01778 cm) and not more than 0.0170 in. (0.004318 cm).
 - {4} Measure the new lower rings (3), they should have an end gap not less than 0.0100 in. (0.0254 cm) and not more than 0.0250 in. (0.0635 cm).

CAUTION

Filing of the ring gap must only go from outside to inside to prevent chipping of the chrome molly plate on the rings. Failure to comply will result in damage to equipment.

NOTE

The ends of the ring must remain square and the chamfer on the outer edge must be approximately 0.015 in. (0.00381 cm).

- d. If the ring gap is too small, file the ends of the ring so the ring must remain at a 90° angle to the cylinder wall.
 - e. If the ring gap is too large, measure the cylinder liner, if the liner is within tolerances, replace the ring. If the liner is not within tolerances replace the liner and remeasure the ring gap.
 - f. Using the same procedure, measure the end gap on all the rings.
2. Measure the piston ring side clearance.
 - a. Ensure the piston ring grooves are clean and free of debris.

- b. Support the piston (1) on its side and place the outer edge of the piston rings (3 or 5) in the piston ring groove.

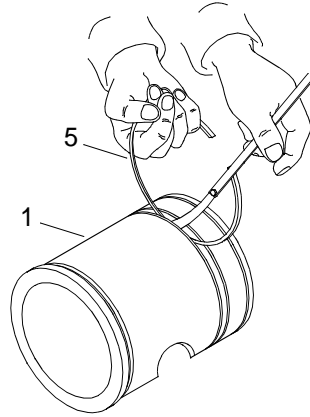

- c. Using a feeler gage between one of the rings (5) and the piston ring groove, measure the clearance as follows.

{1} Measure the top fire ring, it should have a side clearance not less than 0.0010 in. (0.00254 cm) and not more than 0.0050 in. (0.0127 cm).

{2} Measure the middle compression ring, it should have a side clearance not less than 0.0100 in. (0.0254 cm) and not more than 0.0130 in. (0.03302 cm).

{3} Measure the bottom compression ring, it should have a side clearance not less than 0.0040 in. (0.01016 cm) and not more than 0.0070 in. (0.01778 cm).

- d. Follow the same procedure to measure clearance in 90° increments around the piston (1).

FIT PISTONS

1. Measure the piston skirt (11) lengthwise and crosswise of the piston pin journal.
2. With the cylinder liner (2) installed in the block, hold cylinder (1) upside down in the liner (2).

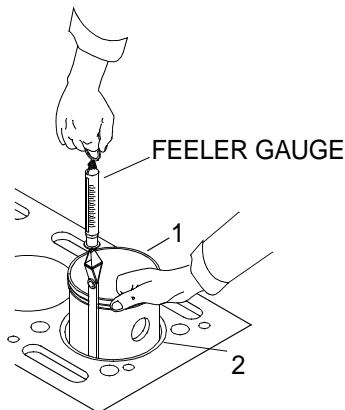

3. Measure the clearance in four places 90° apart.
 - a. Use spring scale feeler gage set to measure the clearance between the piston (1) and liner (2), a minimum of 0.0051 in. (0.01295 cm) or a maximum clearance of 0.0120 in. (0.03048 cm) is allowed.
 - b. Use the spring scale to measure six lb of pull to remove the feeler gage.

INSTALL RINGS**CAUTION**

Do not expand rings more than necessary or damage to equipment may occur.

1. Install new compression and fire rings (5).

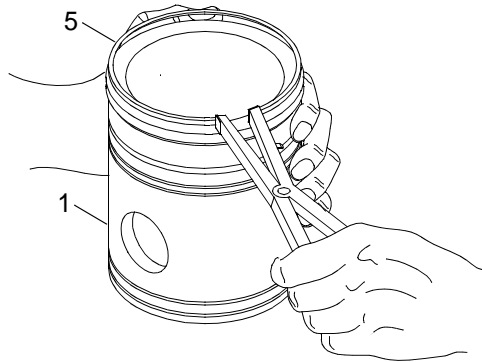

2. Using the tool, expand one of the compression and fire rings (5).
3. Start with the bottom compression and fire ring (5) and work up to the top.
4. Stagger the end gaps so they are at 0°, 120° and 240°.
5. Install new oil control rings (3 and 4).

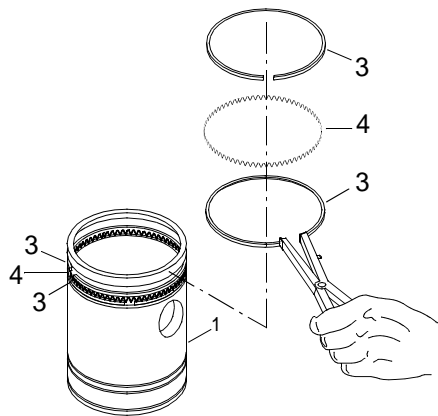

- a. Using tool, install expander ring (4) in piston (1).
- b. Install top oil control ring (3) in the top of the oil ring groove above the oil ring expander (4).
- c. Rotate oil control ring (3) end gap 180° from expander (4) end gap.
- d. Install lower oil control ring (3) below the oil ring expander (4) in the bottom of the oil ring groove.
- e. Rotate oil control ring (3) end gap 90° from expander (4) end gap.
- f. Follow the same procedure for the second set of oil control rings.

INSTALL CONNECTING RODS

WARNING

**CHEMICAL****EYE PROTECTION**

1. Lightly coat threads of bolt (8) with engine oil.

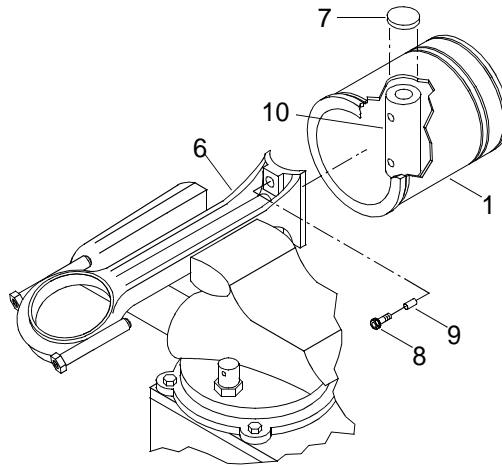

2. Install spacers (9) on connecting bolts (8).
3. Install piston (1) to connecting rod (6) using bolts (8).
4. Clamp the connecting rod (6) in a vice equipped with soft vice caps.
5. Using torque wrench, torque bolts to 55-60 ft lb (75-81 N-m).
6. Install new piston pin retainer (7).

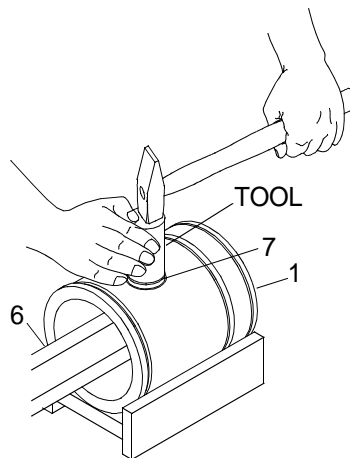

CAUTION

Do not hold piston in a vice to install piston pin retainers. Failure to comply could result in damage to equipment.

7. Support piston assembly (1) on a solid surface using wooden blocks so that it cannot roll.
8. Place a new piston pin retainer (7) in position on the piston (1).
9. Place crowned end of installer against the retainer (7) and strike the retainer with a hammer just hard enough to drive the piston pin retainer (7) into the piston.
10. Ensure the piston pin retainer (7) is seated properly.
11. Install the other piston pin retainer (7) using the same steps.

TEST RETAINER FOR LEAKS

1. Place the suction cup of vacuum gage tester over the retainer (7).

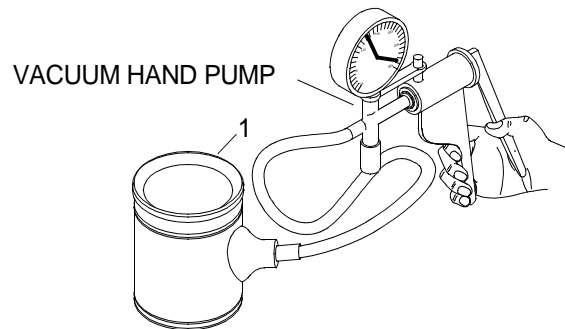
NOTE

A leak at the piston pin retainer is indicated by a drop in the reading during the following procedure.

2. Operate the lever on the vacuum gage tester to 10 in.Hg on the gauge. Repair as necessary.

INSTALL PISTONS IN LINERS

WARNING

CHEMICAL

EYE PROTECTION

1. Apply engine oil to piston rings (3, 4 and 5).

WARNING

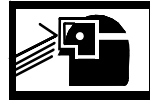
**CHEMICAL****EYE PROTECTION**

- Lubricate the inside of the cylinder liner (2) with engine oil.

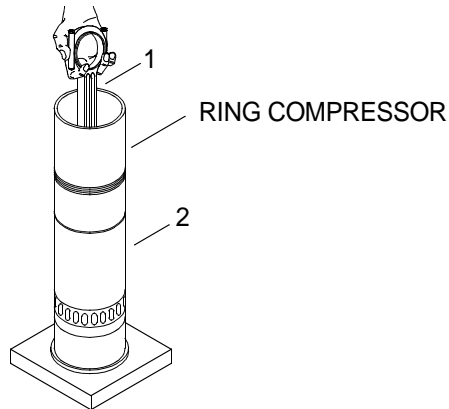

- Install piston (1) in liner (2).
- Insert piston assembly (1) into ring compressor tool.

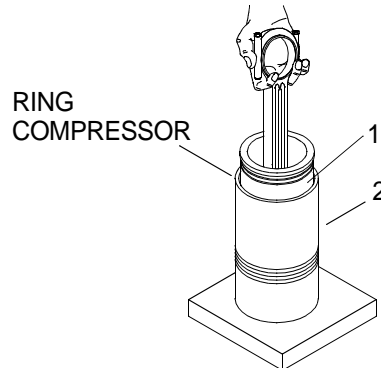

- Have one soldier hold the cylinder liner (2) on a block of wood with the flange end down.
- Have the other soldier place the ring compressor with piston assembly (1) on the cylinder liner (2).
- Align the numbers on the connecting rod (6) with the marks on the liner (2).
- Push the piston assembly (1) into the cylinder liner (2) until it is free of the ring compressor.

END OF WORK PACKAGE

**GENERAL SUPPORT MAINTENANCE
CAUSEWAY FERRY
VIBRATION DAMPER
REPLACEMENT**

INITIAL SETUP:**Tools**

Tool Kit, General Mechanic's (Item 130, WP 0188 00)
Puller Kit, Universal (Cross Bar) (Item 99, WP 0188 00)
Wrench, Torque (0-175 ft lbs) (Item 138, WP 0188 00)
Wrench, Torque (100-600 ft lbs) (Item 139, WP 0188 00)
Wrench Set, Socket ($\frac{3}{4}$ in. sqdr.) (Item 134, WP 0188 00)
Hammer, Hand, (Dead Blow) (Item 59, WP 0188 00)
Gloves, Chemical (Item 52, WP 0188 00)
Goggles, Industrial (Item 54, WP 0188 00)

Materials/Parts

Damper, Vibration, Engine
(72582)
NSN 2841-01-051-9849
PN 8922492
Ring, Retaining
(72582)
NSN 5325-01-286-3994
PN 23503769
Oil, Lubricating, Engine, 10W (Item 25, WP 0187 00)

Personnel Required

Engineer 88L

References

TM 55-1945-205-10-1

Equipment Condition

Alternator Belt Guard Removed. (TM 55-1945-205-24-1-1)
Alternator Belt Removed. (TM 55-1945-205-24-1-1)

REMOVE VIBRATION DAMPER**NOTE**

The following procedure is typical for the removal and installation of the crankshaft vibration dampers on both port and starboard engines.

1. Remove crankshaft pulley retaining bolt (1) and washer (2).

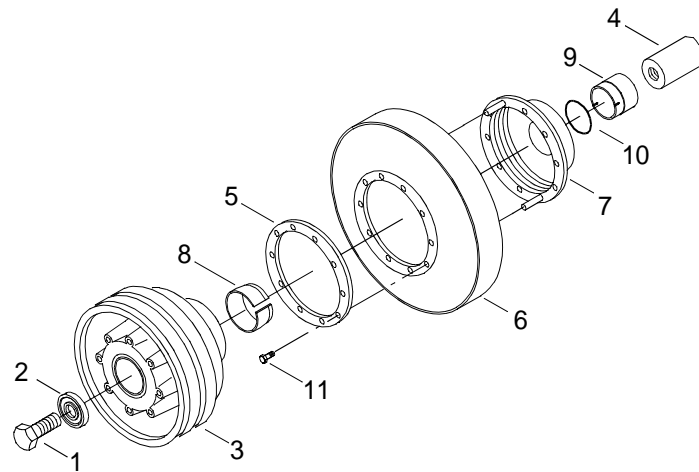

2. Using puller, remove crankshaft pulley (3).
3. Install pulley retaining bolt (1) in crankshaft (4).
4. Using puller, remove scuff plate (5), vibration damper (6), hub (7) and outer cone (8), as an assembly, until outer cone (8) is loose on the crankshaft (4).
5. Using a punch, separate outer cone (8) from vibration damper (6).
6. Remove puller and pull outer cone (8) off crankshaft (4).
7. Remove scuff plate (5), vibration damper (6) and hub (7), as an assembly, off crankshaft (4).
8. Remove inner cone (9) from the crankshaft (4).
9. Remove and discard seal ring (10) from inner core (9).
10. Remove eight bolts (11) from scuff plate (5).
11. Remove scuff plate (5) and hub (7) from vibration damper (6). Discard vibration damper (6).

INSTALL VIBRATION DAMPER

WARNING

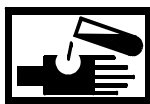

CHEMICAL



EYE PROTECTION

NOTE

All parts on the front of the crankshaft must be installed easily without using force.

1. Lubricate new seal ring (10) with engine lubricating oil.

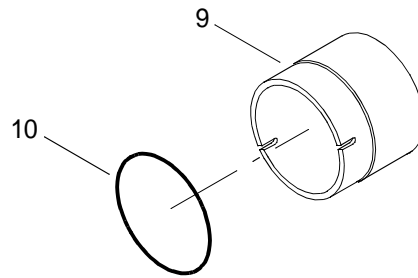

2. Install new seal ring (10) in groove inside inner cone (9).

NOTE

The tapered end of the inner cone must point toward the front end of the crankshaft.

3. Slide inner cone (9) over end of crankshaft (4), through the oil seal (12) and against the oil pump drive hub (13).

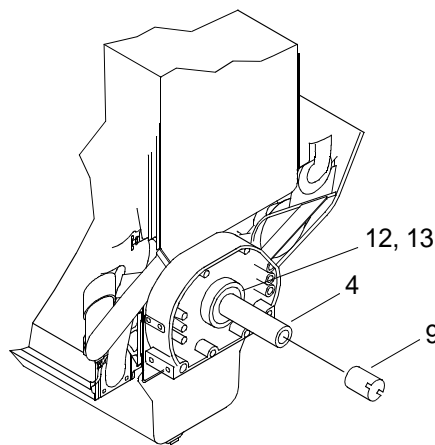

4. Assemble new vibration damper (6) and hub (7).
 - a. Place the vibration damper/hub assembly (6 and 7) over the dowel pins (14).

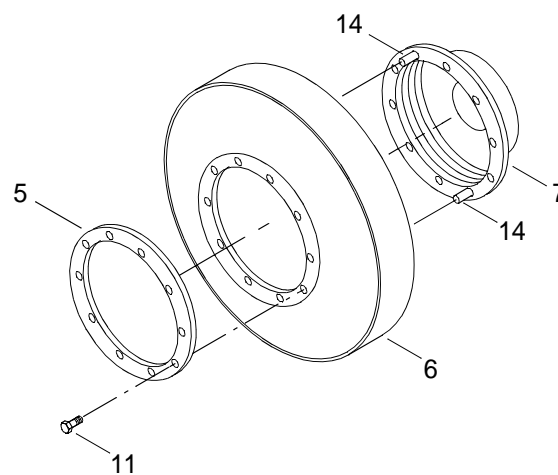

- b. Place scuff plate (5) over dowels (4) and against vibration damper (6).
 - c. Install eight lock bolts (11).

- d. Using torque wrench, torque bolts (11) to 75 - 85 ft lbs (102 - 115 N-m).
5. Install vibration damper (6) assembly over end of crankshaft (4) with long end of hub (7) facing inner cone (9).

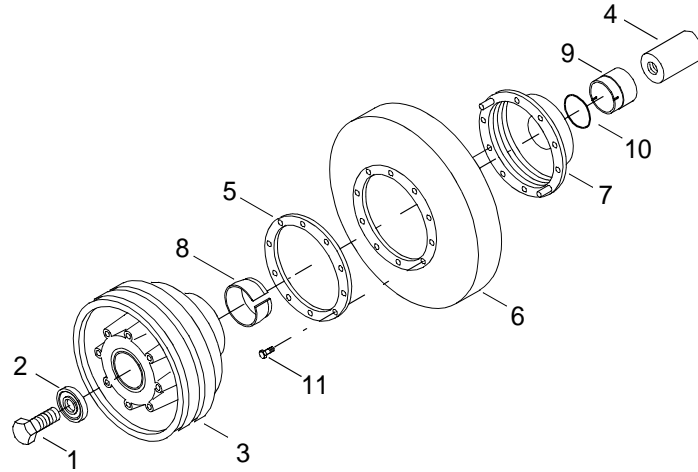

6. Install outer cone (8) over end of crankshaft (4) and against hub (7) with tapered end of cone (8) pointing toward hub (7).
7. Remove crankshaft pulley retaining bolt (1) from crankshaft (4).
8. Install pulley (3) on crankshaft (4).
9. Install lock washer (2) and crankshaft pulley retaining bolt (1).
10. Tighten crankshaft pulley retaining bolt (1).
- Using torque wrench, torque bolt (1) to 180 ft lbs (245 N-m).
 - Strike end of bolt (1) a sharp blow with a dead blow hammer.
 - Using a torque wrench, torque bolt (1) to 300 ft lbs (407 N-m).
 - Strike end of bolt (1) a sharp blow with a dead blow hammer.
 - Using a torque wrench, torque bolt (1) to 290 - 310 ft lbs (393 - 420 N-m).
11. Install alternator belt. (TM 55-1945-205-24-1-1)
12. Install alternator belt guard. (TM 55-1945-205-24-1-1)
13. Perform operational checks. (TM 55-1945-205-10-1)

END OF WORK PACKAGE

**GENERAL SUPPORT MAINTENANCE
CAUSEWAY FERRY
FRONT BALANCE WEIGHT COVER
REPAIR**

INITIAL SETUP:**Tools**

Tool Kit, General Mechanic's (Item 130, WP 0188 00)
Press, Arbor, Hand Operated (Item 97, WP 0188 00)
Apron, Utility (Item 8, WP 0188 00)
Gloves, Chemical (Item 52, WP 0188 00)
Goggles, Industrial (Item 54, WP 0188 00)

Materials/Parts

Seal, Plain Encased
(72582)
NSN 5330-01-377-2000
PN 23512418
Cleaner (Item 8, WP 0187 00)
Oil, Lubricating, Engine, 10W (Item 25, WP 0187 00)

Personnel Required

Engineer 88L

DISASSEMBLE FRONT BALANCE COVER

1. Place front balance weight cover (1) on table of hand operated arbor press.

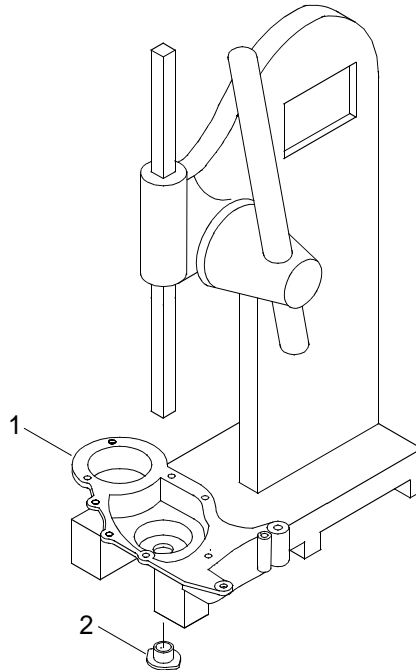

WARNING

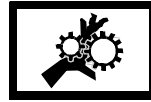
**EYE PROTECTION****MOVING PARTS**

2. Press oil seal (2) from front balance weight cover (1). Discard oil seal (2).

CLEAN BALANCE WEIGHT COVER

WARNING

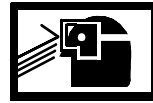
**CHEMICAL****EYE PROTECTION**

1. Using cleaner, clean any grease, oil and dirt from the cover (1).

WARNING

**EYE PROTECTION**

2. Dry cover (1) with compressed air.

INSPECT BALANCE WEIGHT COVER

1. Inspect balance weight cover (1) for cracks, dents or damage that may impair the operation of the balance weight cover. If found, replace balance weight cover (1).
2. Inspect oil seal mating surface (3) of front balance weight cover (1) for nicks, scratches and burrs. If found, replace front balance weight cover (1).

ASSEMBLE FRONT BALANCE WEIGHT COVER

WARNING**CHEMICAL****EYE PROTECTION**

1. Lightly lubricate outer surface of new oil seal (2) with lubricating oil.

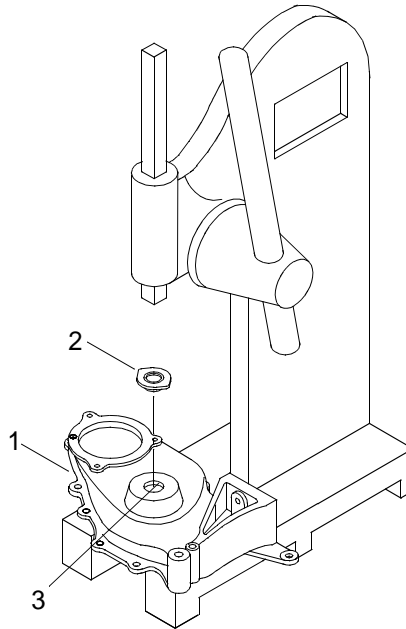

2. Install oil seal (2) in front balance weight cover (1).
 - a. Place front balance weight cover (1) on table of hand operated arbor press.
 - b. Press oil seal (2) into front balance weight cover (1), seal lip facing inward, until oil seal (2) is flush with front edge of balance weight cover (1).

END OF WORK PACKAGE

**DIRECT SUPPORT MAINTENANCE
CAUSEWAY FERRY
FRONT BALANCE WEIGHT COVER
REMOVAL AND INSTALLATION**

INITIAL SETUP:**Tools**

Tool Kit, General Mechanic's (Item 130, WP 0188 00)
Mallet, Rubber (Item 81, WP 0188 00)
Wrench, Torque (150-750 in. lbs) (Item 142, WP 0188 00)
Wrench Set, Socket (3/8 in. sqdr.) (Item 135, WP 0188 00)
Gloves, Chemical (Item 52, WP 0188 00)
Goggles, Industrial (Item 54, WP 0188 00)

Materials/Parts

Gasket
(72582)
NSN 5330-01-350-4262
PN 5123638
Cleaner (Item 08, WP 0187 00)

Personnel Required

Engineer 88L

References

TM 55-1945-205-10-1

Equipment Condition

Main Navigation Mast Removed. (TM 55-1945-205-24-1-1)
SINCGARS Antenna Removed. (TM 11-5820-890-10-8)
Powered Section Intake Plenum Or Operators Cab Removed. (TM 55-1945-205-24-1-1)
Powered Section Engine Hatch Removed. (TM 55-1945-205-24-1-1)
Alternator Belt Guard Removed. (TM 55-1945-205-24-1-1)
Engine Cool To Touch.
Fresh Water Cooling System Drained. (WP 0134 00)
Heat Exchanger Removed. (WP 0138 00)
Fresh Water Pump Removed. (WP 0152 00)
Forward Lifting Bracket Removed. (WP 0139 00)

REMOVE FRONT BALANCE WEIGHT COVER ASSEMBLY**NOTE**

Bolts vary in length, tag all bolts for reinstallation in the proper location.

1. Remove two bolts (1) and two flat washers (2) from front balance weight cover assembly (3).

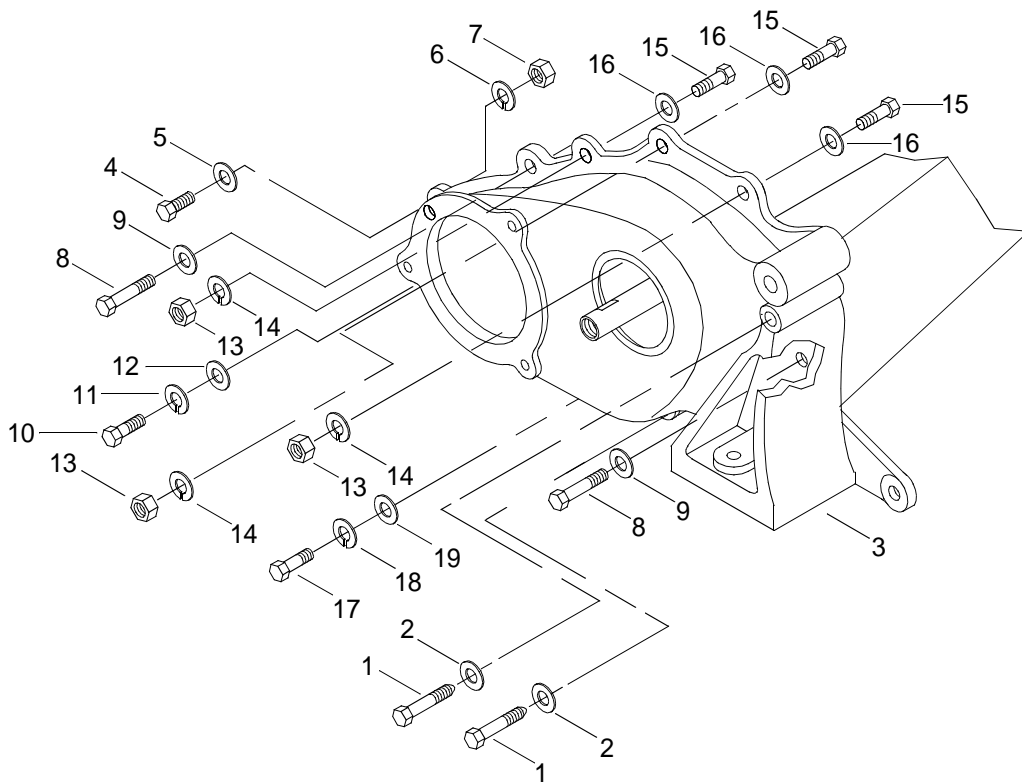

2. Remove bolt (4), washer (5), lock washer (6) and nut (7) from front balance weight cover (3).
3. Remove two bolt (8) and two washers (9) from front balance weight cover (3).
4. Remove bolt (10), lock washer (11) and washer (12) from balance weight cover (3).
5. Remove three nuts (13), lock washers (14) from bolt (15).
6. Remove bolt (15) and lock washers (16) from balance weight cover (3).
7. Remove bolt (17), lock washer (18) and washer (19) from front balance weight cover (3).
8. If necessary, use a rubber mallet to break the seal between the front balance weight cover (4) and the engine (20).

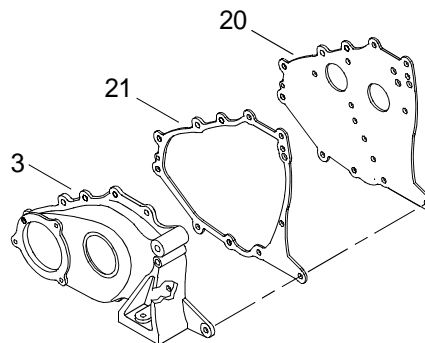

9. Remove front balance weight cover (3).
10. Remove gasket (20) and discard.

INSTALL FRONT BALANCE WEIGHT COVER

WARNING

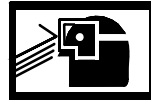
**CHEMICAL****EYE PROTECTION**

1. Using cleaner, clean engine (20) and front balance weight cover (3) of gasket material.
2. Install a new gasket (21) on engine (20).
3. Install front balance weight cover (3) on engine (20).
4. Install bolt (17), lock washer (18) and washer (19) into front balance weight cover (3).
5. Install bolt (15) and lock washers (16) into front balance weight cover (3).
6. Install three nuts (13) lock washers (14) on bolt (15).
7. Install bolts (10), lock washer (11), washer (12) into front balance weight cover (3).
8. Install two bolts (8) and washers (9) into front balance weight cover (3).
9. Install bolt (4), washer (5) lock washer (6) and nut (7) into front balance weight cover (3).
10. Install two bolts (1) and two flat washers (2) from front balance weight cover (3).
11. Using a torque wrench, torque bolts (17) to 420-480 in. lbs (40-47 N-m).
12. Using a torque wrench, torque nuts (13) to 360-420 in. lbs (40-47 N-m).
13. Using a torque wrench, torque bolts (10) to 420-480 in. lbs (47-54 N-m).
14. Using a torque wrench, torque bolts (8) to 420-480 in. lbs (47-53 N-m).
15. Using a torque wrench, torque bolts (4) to 360-420 in. lbs (40-47 N-m).
16. Using a torque wrench, torque bolts (1) to 420-480 in. lbs (47-53 N-m).
17. Install fresh water pump. (WP 0152 00)
18. Install forward lifting bracket. (WP 0139 00)
19. Install heat exchanger. (WP 0138 00)
20. Service fresh water cooling system. (WP 0133 00)
21. Install alternator belt guard. (TM 55-1945-205-24-1-1)
22. Install powered section engine hatch. (TM 55-1945-205-24-1-1)

23. Install powered section intake plenum or operators cab. (TM 55-1945-205-24-1-1)
24. Install main navigation mast. (TM 55-1945-205-24-1-1)
25. Install SINGARS antenna. (TM 11-5820-890-10-8)
26. Perform operational checks. (TM 55-1945-205-10-1)

END OF WORK PACKAGE

**UNIT LEVEL MAINTENANCE
CAUSEWAY FERRY
FUEL SYSTEM
PRIMING**

INITIAL SETUP:**Tools**

Tool Kit, General Mechanic's (Rail and Marine) (Item 130, WP 0188 00)
Gloves, Chemical (Item 52, WP 0188 00)
Goggles, Industrial (Item 54, WP 0188 00)
Pan, Drain (Item 87, WP 0188 00)

Materials/Parts

Spill Clean-Up Kit, Hazardous Material (Item 32, WP 0187 00)

Personnel Required

Engineer 88L

References

TM 55-1945-205-10-1

Equipment Condition

Engine Cool To Touch.

PRIME THE FUEL SYSTEM

1. Position drain pan under fuel return line (1).

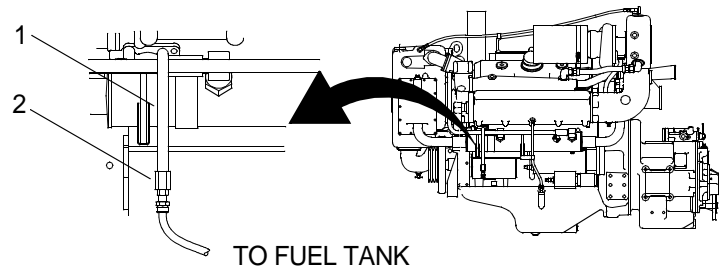

WARNING

**CHEMICAL****EYE PROTECTION**

2. Disconnect fuel return line (1) from fitting (2).

3. Push knob (3) on fuel priming pump (4) in and rotate $\frac{1}{4}$ turn counterclockwise.

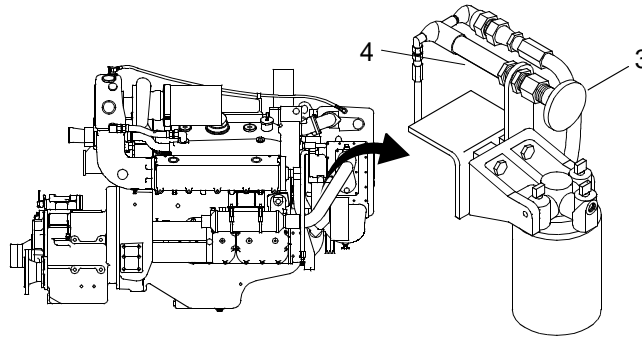
**WARNING**

CHEMICAL



EYE PROTECTION

4. Pump knob (3) until fuel flows, from fuel return line (1), in a steady stream with no bubbles.
5. Push knob (3) in completely and rotate $\frac{1}{4}$ turn clockwise to lock.

WARNING

CHEMICAL



EYE PROTECTION

6. Connect fuel return line (1) to fitting (2).
7. Tighten fitting (2).

WARNING

CHEMICAL



EYE PROTECTION

8. Remove drain pan and dispose of contents in accordance with local procedure.

WARNING

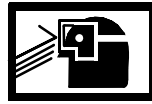
**CHEMICAL****EYE PROTECTION****SLICK FLOOR**

9. Clean up spilled fluid with spill kit and dispose of spill kit waste in accordance with local procedure.
10. Perform operational check of diesel engine. (TM 55-1945-205-10-1)

END OF WORK PACKAGE

**UNIT LEVEL MAINTENANCE
CAUSEWAY FERRY
FUEL SYSTEM
TESTING**

INITIAL SETUP:**Tools**

Tool Kit, General Mechanic's (Rail and Marine) (Item 131, WP 0188 00)
 Pail, Utility (Item 86, WP 0188 00)
 Pan, Drain (Item 87, WP 0188 00)
 Elbow, Pipe to Tube (Item 35, WP 0188 00)
 Thermometer, Self-Indicating (Item 127, WP 0188 00)
 Gloves, Chemical (Item 52, WP 0188 00)
 Goggles, Industrial (Item 54, WP 0188 00)

Materials/Parts

Parts Kit, Fuel Injector, Diesel Engine
 (72582)
 NSN 2910-00-073-3010
 PN 5229649
 Spill Clean-Up Kit, Hazardous Material (Item 32, WP 0187 00)

Personnel Required

Engineer 88L

References

TM 55-1945-205-10-1
 TM 55-1945-205-24-1-1
 TM 11-5820-890-10-8

PERFORM FUEL FLOW TEST**NOTE**

This test is typical for both port and starboard engines.

1. Verify MAIN circuit breaker (1) on propulsion module circuit breaker panel A6 is off.

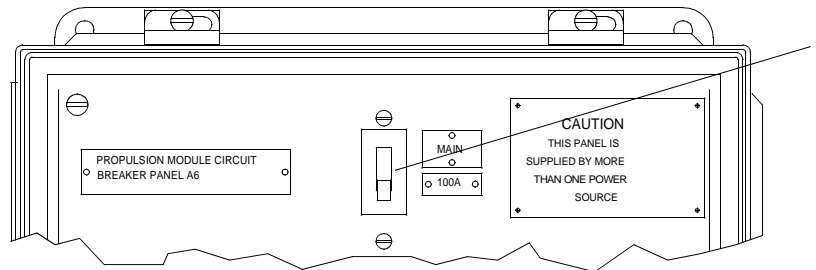

2. Place a drain pan under fuel return line (2).

WARNING

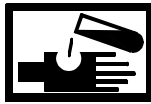
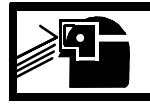
**CHEMICAL****EYE PROTECTION**

3. Disconnect fuel return line (2) at ball valve (3).

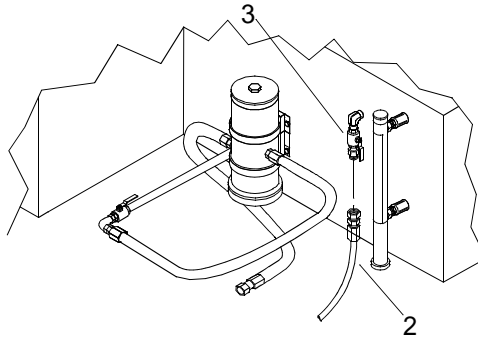

WARNING

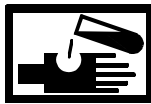
**CHEMICAL****EYE PROTECTION**

4. Install restriction elbow (4) on the end of fuel return line (2).

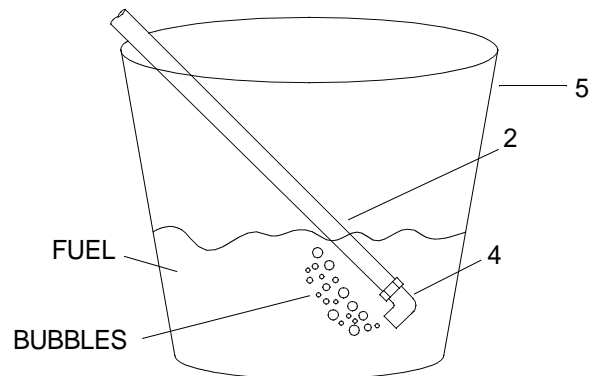

WARNING

**CHEMICAL****EYE PROTECTION**

5. Place the end of fuel return line (2) in a clean five gallon utility pail (5).

-
6. Start engine. (TM 55-1945-205-10-1)

WARNING

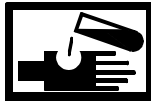

CHEMICAL

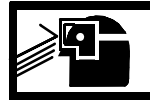

EYE PROTECTION

7. Quickly raise engine to 1800 RPM's and run for one minute.

WARNING

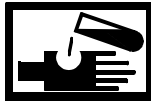

CHEMICAL

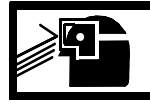

EYE PROTECTION

8. Watch the fuel for bubbles.
9. Shut engine down. (TM 55-1945-205-10-1)

NOTE

Air bubbles present in the fuel indicate a leak on the suction side of the pump.

10. If bubbles were present in the fuel, check and tighten all fuel lines and connections between the fuel tank and the input side of the fuel pump. (WP 0080 00)
11. If bubbles were present, repeat steps 4 thru 10.

WARNING

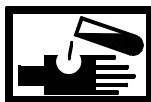

CHEMICAL



EYE PROTECTION

12. If no bubbles were present, measure the amount of fuel in the utility pail (5).

NOTE

A minimum of 0.9 gals of fuel is required for the pump to pass this test.

13. If a minimum of 0.9 gallons of fuel was not delivered to the utility pail, replace the fuel cartridge. (WP 0079 00)

WARNING

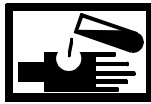
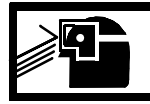
**CHEMICAL****EYE PROTECTION**

14. Pour fuel from utility pail, back in fuel tank.
15. Start engine and run at 1800 RPM's for one minute. (TM 55-1945-205-10-1)
16. Repeat steps 8 thru 14.
17. If the fuel pump fails again, repair the fuel pump. (WP 0095 00)
18. Repeat steps 4 through 10 and verify that the fuel pump passes.

WARNING

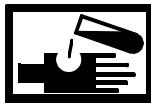
**CHEMICAL****EYE PROTECTION**

19. Remove elbow (4) from fuel return line (2).

WARNING

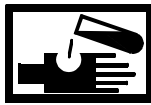
**CHEMICAL****EYE PROTECTION**

20. Install fuel return line (2) on ball valve (3).

WARNING

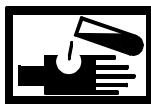
**CHEMICAL****EYE PROTECTION**

21. Remove drain pan and dispose of contents in accordance with local procedure.

WARNING

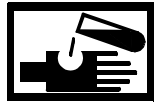
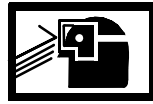
**CHEMICAL****EYE PROTECTION****SLICK FLOOR**

22. Clean up spilled fluid with spill kit and dispose of spill kit waste in accordance with local procedure.

PERFORM INJECTOR CUT OUT TEST**NOTE**

This test is typical for both port and starboard engines.

1. Verify the engine is cool to the touch.
2. Remove SINCGARS antenna. (TM 11-5820-890-10-8)
3. Remove main navigation mast. (TM 55-1945-205-24-1-1)
4. Remove intake plenum assembly. (TM 55-1945-205-24-1-1)
5. Remove operators cab. (TM 55-1945-205-24-1-1)
6. Remove engine hatch. (TM 55-1945-205-24-1-1)
7. Remove crankcase breather limiter assembly. (WP 0106 00)
8. Remove engine air inlet collector assembly. (WP 0104 00)
9. Remove engine poppet valve rocker cover. (WP 0043 00)
10. Install air inlet collector assembly. (WP 0104 00)
11. Install crankcase breather limiter assembly. (WP 0106 00)
12. Start engine and run idle speed. (TM 55-1945-205-10-1)

WARNING

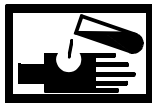
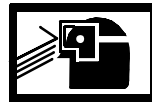
**CHEMICAL****EYE PROTECTION**

13. Using a screwdriver, hold down injector follower (6) on the starboard bank number one injector (7).

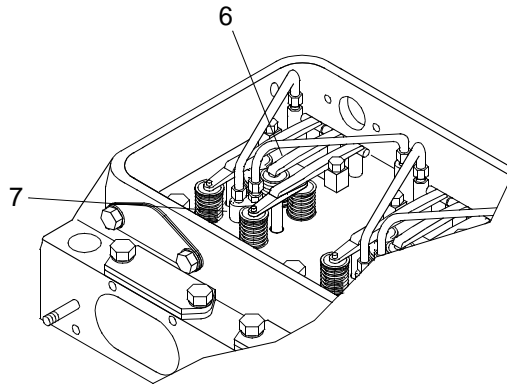

NOTE

When cutting out one injector, there should be a noticeable change in the sound and operation of the engine. If there is none, the injector is misfiring.

14. While holding down the injector follower (6), listen to the sound and notice the operation of the engine.
15. If there was a noticeable change repeat steps 13 and 14 for the remaining seven injectors (7).
16. If there was no noticeable change, shut engine down. (TM 55-1945-205-10-1)

WARNING



CHEMICAL

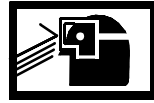

EYE PROTECTION

17. Remove injector inlet line (8) from injector (7) and injector manifold (9).

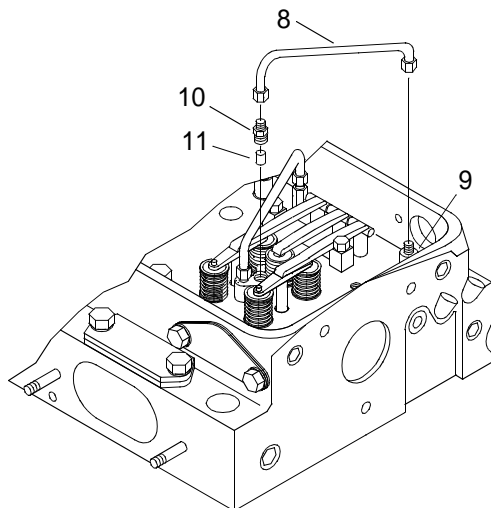

WARNING

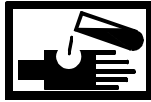
**CHEMICAL****EYE PROTECTION**

18. Place a finger over the opening in injector manifold (9).
19. Crank the engine without allowing it to start.

WARNING

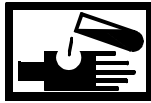
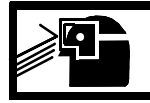
**CHEMICAL****EYE PROTECTION**

20. Verify that there is an ample amount of fuel reaching the injector (7).

WARNING

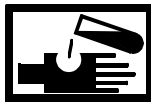
**CHEMICAL****EYE PROTECTION**

21. If an ample amount of fuel is reaching the injector, remove injector inlet fitting (10).

WARNING

**CHEMICAL****EYE PROTECTION**

22. Remove injector filter (11) from injector (7) and discard.
23. Install new injector filter (11) in injector (7).
24. Install injector inlet fitting (10).
25. Install injector inlet line (8) on injector (7) and injector manifold (9).
26. Repeat steps 12 thru 14.
27. If there still was no noticeable change, replace injector (7). (WP 0091 00)
28. If there was a noticeable change repeat steps 13 and 14 for the remaining seven injectors (7).

NOTE

If the fuel line was removed and the engine was operated, step 28 must be performed.

29. Service the lube oil system crankcase. (WP 0115 00)
30. Remove crankcase breather limiter assembly. (WP 0106 00)
31. Remove engine air inlet collector assembly. (WP 0104 00)
32. Install engine poppet valve rocker cover. (WP 0043 00)
33. Install engine air inlet collector assembly. (WP 0104 00)
34. Install crankcase breather limiter assembly. (WP 0106 00)
35. Install engine hatch. (TM 55-1945-205-24-1-1)
36. Install operators cab. (TM 55-1945-205-24-1-1)
37. Install intake plenum assembly. (TM 55-1945-205-24-1-1)
38. Install main navigation mast. (TM 55-1945-205-24-1-1)
39. Install SINGARS antenna. (TM 11-5820-890-10-8)

PERFORM FUEL SPILL BACK TEMPERATURE TEST**NOTE**

This test is typical for both port and starboard engines

1. Start engine. (TM 55-1945-205-10-1)
2. Operate engine for ten minutes after normal operating temperature has been reached.
3. Shut engine down. (TM 55-1945-205-10-1)
4. Position drain pan under fuel return line (2).

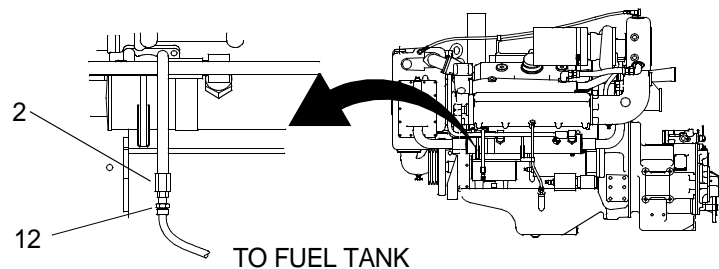

WARNING

**CHEMICAL****EYE PROTECTION**

5. Disconnect fuel return line (2) from fitting (12).

WARNING

**CHEMICAL****EYE PROTECTION**

6. Start engine and run for several seconds allowing an inch of fuel to accumulate in the drain pan.

WARNING

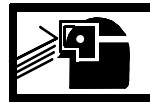
**CHEMICAL****EYE PROTECTION**

7. Using a thermometer, measure the temperature of the fuel.

NOTE

If the fuel temperature exceeds 150°F (66°C), 8% horsepower will be lost for every 20°F increase. (Metric conversions, on increasing increments, are not proportional to standard temperatures.)

8. Verify the fuel temperature is below 150°F (66°C).
9. If the fuel temperature is above 150°F (66°C), replace the fuel cooler. (WP 0081 00)

WARNING

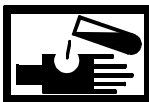
**CHEMICAL****EYE PROTECTION**

10. Connect fuel return line (2) to fitting (12).

WARNING

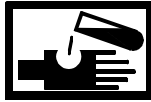
**CHEMICAL****EYE PROTECTION**

11. Remove drain pan and dispose of contents in accordance with local procedure.

WARNING

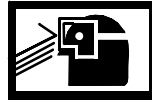
**CHEMICAL****EYE PROTECTION****SLICK FLOOR**

12. Clean up spilled fluid with spill kit and dispose of spill kit waste in accordance with local procedure.

END OF WORK PACKAGE

**UNIT LEVEL MAINTENANCE
CAUSEWAY FERRY
FUEL FILTER CARTRIDGE
REPLACEMENT**

INITIAL SETUP:**Tools**

Tool Kit, General Mechanic's (Rail and Marine) (Item 131, WP 0188 00)
 Gloves, Chemical (Item 52, WP 0188 00)
 Goggles, Industrial (Item 54, WP 0188 00)
 Pan, Drain (Item 87, WP 0188 00)
 Wrench, Strap (Item 137, WP 0188 00)

Materials/Parts

Filter, Cartridge
 (72582)
 NSN 2910-01-450-6813
 PN 23518532
 Fuel, Diesel (Item 19, WP 0187 00)
 Cloth, Cleaning (Item 13, WP 0187 00)

Personnel Required

Engineer 88L

References

TM 55-1945-205-10-1

REMOVE FUEL SYSTEM FILTER CARTRIDGE**NOTE**

The following procedure is typical for both port and starboard engines.

1. Verify MAIN circuit breaker (1) on propulsion module circuit breaker panel A6 is off.

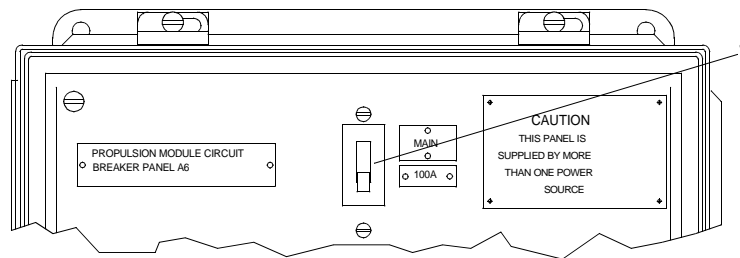

2. Position drain pan beneath filter cartridge (2).

WARNING

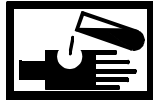
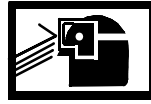
**CHEMICAL****EYE PROTECTION**

3. Remove the fuel filter cartridge (2) from the filter adaptor (3) by turning counterclockwise with a filter wrench.

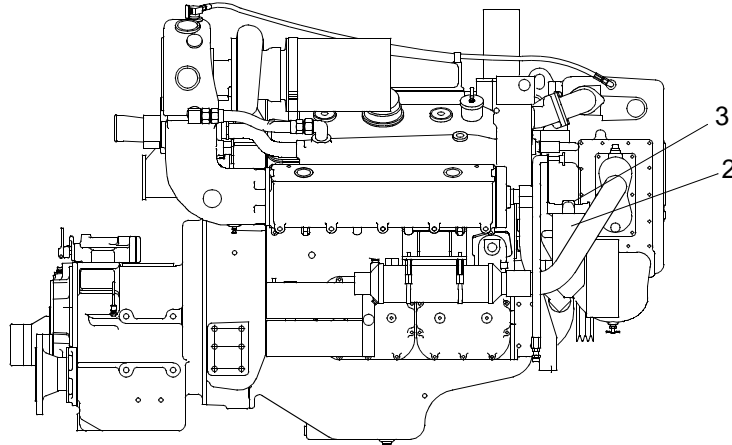

WARNING

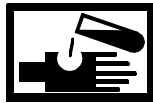
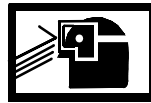
**CHEMICAL****EYE PROTECTION**

CAUTION

Ensure that the filter gasket came off with the fuel filter. Double gasketing will cause massive fuel leaks at the filter. Failure to comply will cause serious damage to equipment.

4. Clean inside the filter adaptor (3) to remove any debris using cleaning cloth.

WARNING

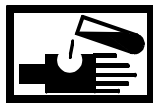
**CHEMICAL****EYE PROTECTION**

5. Remove drain pan and dispose of contents in accordance with local procedures.

WARNING

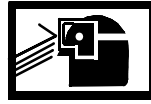
**CHEMICAL****EYE PROTECTION**

6. Discard fuel filter cartridge (2) and contaminated cloth and dispose of in accordance with local procedures.

INSTALL FUEL SYSTEM FILTER CARTRIDGE

WARNING

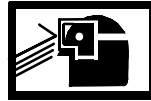
**CHEMICAL****EYE PROTECTION**

1. Apply thin coat of diesel fuel on fuel filter (2) gasket.
2. Install the new fuel filter cartridge (2) on the filter adaptor (3) by turning clockwise by hand until snug.
3. Tighten fuel filter cartridge (2) ¼ additional turn with a filter wrench.
4. Prime fuel system. (WP 0077 00)
5. Start engine. (TM 55-1945-205-10-1)
6. Check fuel lines for leaks.
7. Shut engine down. (TM 55-1945-205-10-1)

END OF WORK PACKAGE

**UNIT LEVEL MAINTENANCE
CAUSEWAY FERRY
FUEL HOSES AND TUBES
REPLACEMENT**

INITIAL SETUP:**Tools**

Tool Kit, General Mechanic's (Rail and Marine) (Item 131, WP 0188 00)
 Gloves, Chemical (Item 52, WP 0188 00)
 Goggles, Industrial (Item 54, WP 0188 00)
 Pan, Drain (Item 87, WP 0188 00)

Materials/Parts

Spill Clean-Up Kit, Hazardous Material (Item 32, WP 0187 00)

Personnel Required

Engineer 88L

References

TM 55-1945-205-10-1

Equipment Condition

Engine Cool To Touch.

REMOVE FUEL TUBES (WITH B-NUTS)**NOTE**

The following procedures are typical for all fuel system rubber hoses/tubes for port and starboard engine fuel systems with b-nuts.

1. Verify MAIN circuit breaker (1) on propulsion module circuit breaker A6 is off.

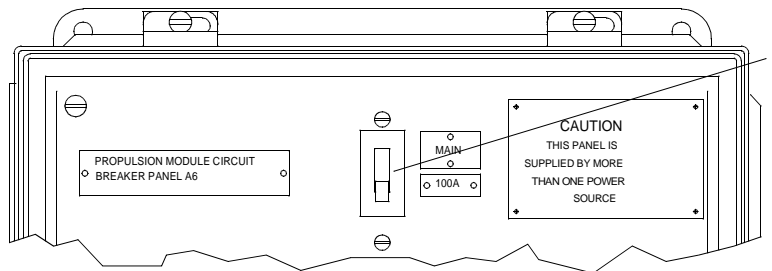

2. Verify fuel supply and return valves (2) are closed.

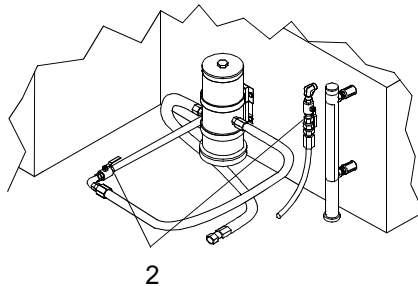

3. Position drain pan under tube (3) being removed.

WARNING



CHEMICAL



EYE PROTECTION

- Loosen b-nut (4) on each end of tube (3).

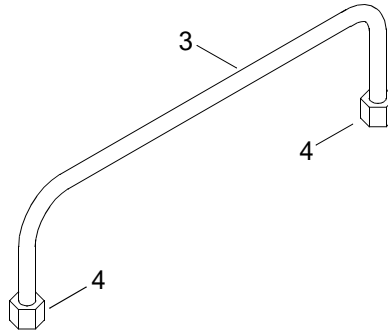

WARNING



CHEMICAL



EYE PROTECTION

- Remove tube (3), drain residual fuel into drain pan. Discard tube (3).

WARNING



CHEMICAL



EYE PROTECTION

- Remove drain pan and dispose of contents in accordance with local procedures.

INSTALL FUEL TUBES (WITH B-NUTS)

- Install tube (3) onto fittings.
- Tighten b-nut (4) at each end of tube (3).

WARNING

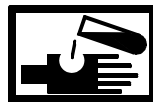

CHEMICAL



EYE PROTECTION



SLICK FLOOR

- Clean up spilled fluid with a spill kit and dispose of spill kit waste in accordance with local procedures.

4. Start engine. (TM 55-1945-205-10-1)
5. Check fuel lines for leaks.
6. Shut down engine. (TM 55-1945-205-10-1)

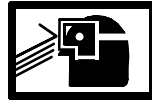
REMOVE FUEL RUBBER HOSES (WITH B-NUT)**WARNING****CHEMICAL****EYE PROTECTION**

1. Position drain pan under hose (5) being removed for draining residual fuel from hose.

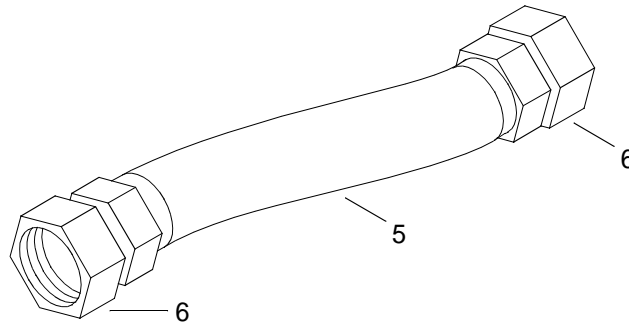
**WARNING****CHEMICAL****EYE PROTECTION**

2. Loosen b-nut (6) at each end of hose (5).

WARNING**CHEMICAL****EYE PROTECTION**

3. Remove hose (5), drain residual fuel into drain pan and discard hose (5).

WARNING

**CHEMICAL****EYE PROTECTION****SLICK FLOOR**

4. Remove drain pan and dispose of drain pan in accordance with local procedures.

INSTALL FUEL RUBBER HOSES (WITH B-NUT)

1. Install hose (5) on fittings.

CAUTION

Do not overtighten b-nut or damage to fitting threads will occur.

2. Tighten b-nut (6) on each end of hose (5).

WARNING

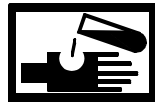
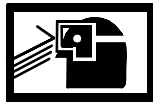
**CHEMICAL****EYE PROTECTION****SLICK FLOOR**

3. Clean up spilled fluid with a spill kit and dispose of spill kit waste in accordance with local procedures.
4. Start engine. (TM 55-1945-205-10-1)
5. Check fuel lines for leaks.
6. Shut down engine. (TM 55-1945-205-10-1)

END OF WORK PACKAGE

**UNIT LEVEL MAINTENANCE
CAUSEWAY FERRY
FUEL COOLER
REPLACEMENT**

INITIAL SETUP:**Tools**

Tool Kit, General Mechanic's (Rail and Marine) (Item 131, WP 0188 00)
Apron, Utility (Item 8, WP 0188 00)
Gloves, Chemical (Item 52, WP 0188 00)
Goggles, Industrial (Item 54, WP 0188 00)
Respirator, Air Filtering (Item 109, WP 0188 00)
Pan, Drain (Item 87, WP 0188 00)

Materials/Parts

Cooler Assembly
(72582)
PN 23508424
Spill Clean-Up Kit, Hazardous Material (Item 32, WP 0187 00)
Tape, Antiseizing (Item 34, WP 0187 00)

Personnel Required

Engineer 88L

References

TM 55-1945-205-10-1

Equipment Condition

Engine Cool To Touch.
Engine Cooling System Drained. (WP 0134 00)

REMOVE FUEL SYSTEM COOLER

1. Verify fuel supply and return valves (1) are closed.

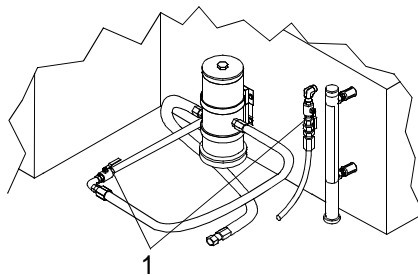

2. Verify butterfly valve (2) on sea chest is off.

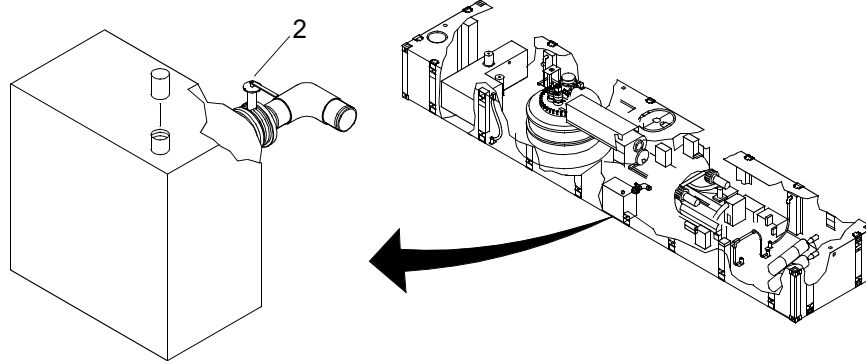

3. Position a drain pan under fuel cooler (5).
4. Remove four clamps (3) from two hoses (4).

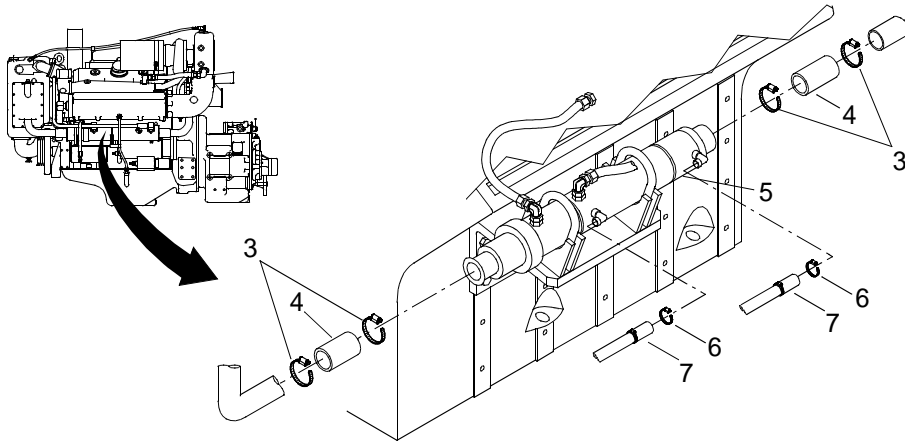

5. Remove two hoses (4) from fuel cooler (5) and allow raw water to drain into the bilge.

WARNING



CHEMICAL

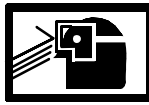

EYE PROTECTION



POISON



VAPOR

6. Remove two clamps (6) from two fresh water coolant hoses (7).

WARNING

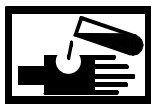

CHEMICAL



EYE PROTECTION



POISON



VAPOR

7. Remove two fresh water coolant hoses (7) from fuel cooler (5) and allow fresh water to drain into the drain pan.

8. Position second drain pan under fuel cooler (5).

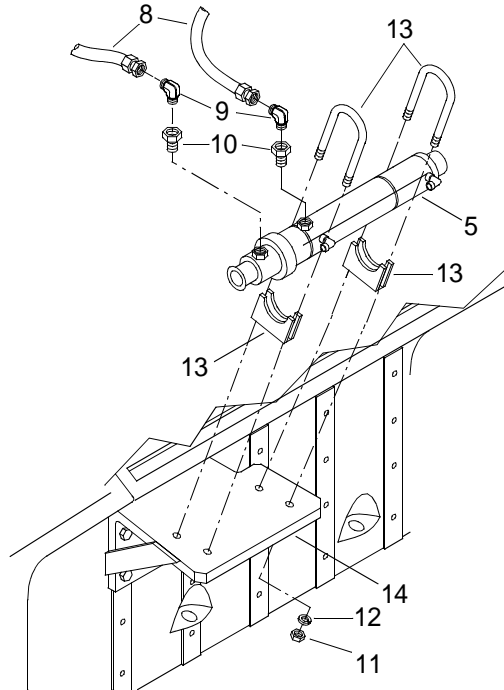

WARNING



CHEMICAL



EYE PROTECTION

9. Remove two fuel lines (8) from elbows (9) and allow fuel to drain into drain pan.

WARNING



CHEMICAL



EYE PROTECTION

10. Remove two elbows (9) from bushings (10).

WARNING

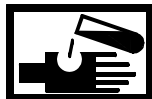

CHEMICAL



EYE PROTECTION

11. Remove two bushings (10) from fuel cooler (5).

12. Remove four hex nuts (11) and lock washers (12) from clamps (13).

13. Remove clamps (13).

14. Remove fuel cooler (5) from bracket (14) and discard.

WARNING



CHEMICAL



EYE PROTECTION



POISON



VAPOR

15. Remove two drain pans and dispose of contents in accordance with local procedures.

INSTALL FUEL SYSTEM COOLER

1. Install clamps (13) on new fuel cooler (3).

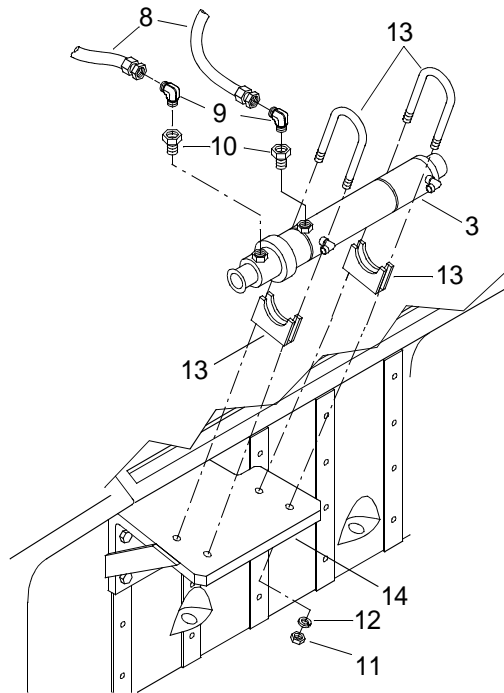

2. Position new fuel cooler (3) on bracket (14).

3. Install four hex nuts (11) and lock washers (12) on clamps (13).

4. Tighten hex nuts (11).

5. Wrap bushing (10) threads with antiseize tape.

6. Install two bushings (10) on fuel cooler (5).

7. Wrap elbows (9) threads with antiseize tape.

8. Install two elbows (9) on bushings (10).

9. Install two fuel lines (8) on elbows (9).

10. Install fresh water coolant hoses (7) on fuel cooler (5).

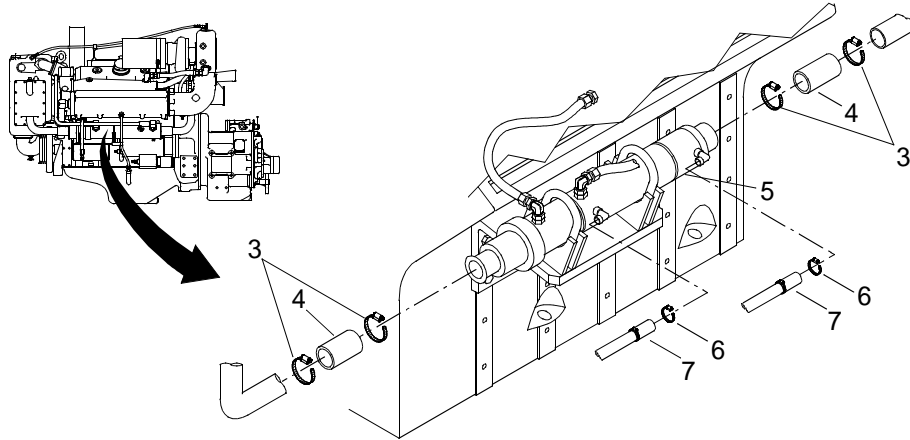

11. Install clamps (6) on fresh water coolant hoses (7).

12. Tighten clamps (6).

13. Install two hoses (5) on fuel cooler (3).

14. Install four clamps (4) on two hoses (5).

15. Tighten clamps (4).

16. Service fresh water cooling system. (WP 0133 00)

17. Prime fuel system. (WP 0077 00)

18. Start engine. (TM 55-1945-205-10-1)

19. Check fuel cooler (4) for leaks.

20. Shut engine down. (TM 55-1945-205-10-1)

21. Service fresh water cooling system. (WP 0133 00)

WARNING



CHEMICAL



EYE PROTECTION



POISON



VAPOR



SLICK FLOOR

22. Clean up spilled fluids with spill kit and dispose of spill kit waste in accordance with local procedure.

END OF WORK PACKAGE

**UNIT LEVEL MAINTENANCE
CAUSEWAY FERRY
FUEL COOLER MOUNTING BRACKET
REPLACEMENT**

INITIAL SETUP:**Tools**

Tool Kit, General Mechanic's (Rail and Marine) (Item 130, WP 0188 00)

Materials/Parts

Bracket
(72582)
PN 23501255

Personnel Required

Engineer 88L

Equipment Condition

Engine Cool To Touch.
Engine Cooling System Drained. (WP 0134 00)
Fuel Cooler Removed. (WP 0081 00)

REMOVE FUEL COOLER MOUNTING BRACKET

1. Remove four cap screws (1) and lock washers (2) from bracket (3).

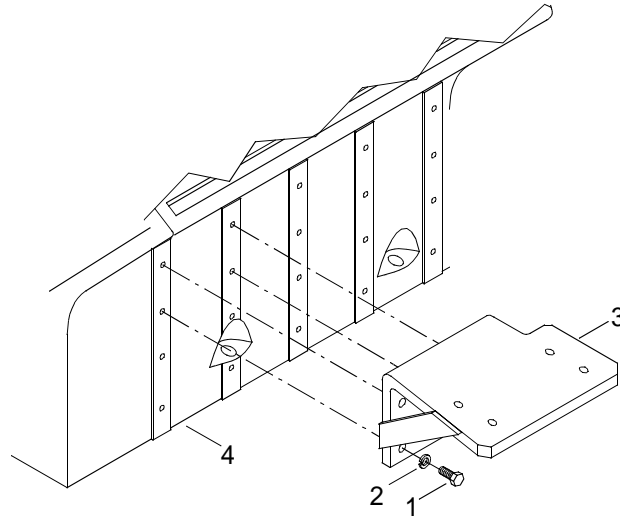

2. Remove bracket (3) from engine (4) and discard.

INSTALL FUEL COOLER MOUNTING BRACKET

1. Position bracket (3) on engine (4).
2. Install four cap screws (1) and lock washers (2) on bracket (3).
3. Tighten cap screws (1).
4. Install fuel cooler. (WP 0081 00)
5. Service fresh water cooling system. (WP 0133 00)

END OF WORK PACKAGE

**UNIT LEVEL MAINTENANCE
CAUSEWAY FERRY
FUEL FILTER ADAPTOR
REPLACEMENT**

INITIAL SETUP:**Tools**

Tool Kit, General Mechanic's (Rail and Marine) (Item 131, WP 0188 00)
Gloves, Chemical (Item 52, WP 0188 00)
Goggles, Industrial (Item 54, WP 0188 00)
Pan, Drain (Item 87, WP 0188 00)

Materials/Parts

Adaptor
(72582)
PN 25011019
Tape, Antiseizing (Item 34, WP 0187 00)

Personnel Required

Engineer 88L

References

TM 55-1945-205-10-1

Equipment Condition

Fuel Filter Cartridge Removed. (WP 0079 00)

REMOVE FUEL FILTER ADAPTOR

1. Place a drain pan under fuel filter adaptor (1).

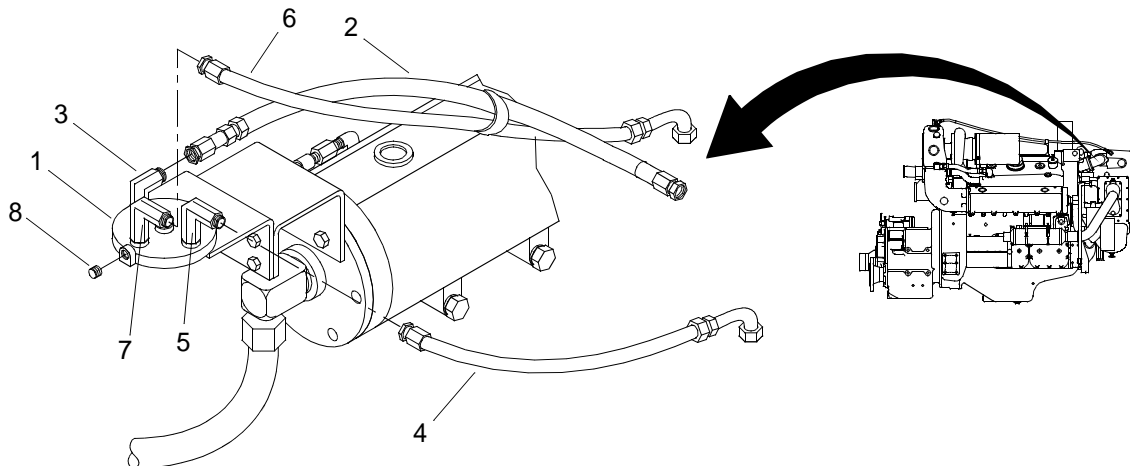

WARNING

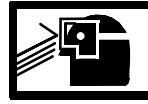
**CHEMICAL****EYE PROTECTION**

2. Disconnect fuel line (2) from elbow (3).

WARNING

**CHEMICAL****EYE PROTECTION**

3. Remove elbow (3) from fuel filter adaptor (1).

WARNING

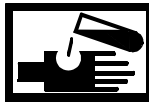
**CHEMICAL****EYE PROTECTION**

4. Disconnect fuel line (4) from elbow (5).

WARNING

**CHEMICAL****EYE PROTECTION**

5. Remove elbow (5) from fuel filter adaptor (1).

WARNING

**CHEMICAL****EYE PROTECTION**

6. Disconnect fuel line (6) from elbow (7).

WARNING**CHEMICAL****EYE PROTECTION**

7. Remove elbow (7) from fuel filter adaptor (1).

WARNING**CHEMICAL****EYE PROTECTION**

8. Remove pipe plug (8) from fuel filter adaptor (1).
9. Remove four hex nuts (9), lock washers (10) and flat washers (11) from cap screws (12) and flat washers (13).

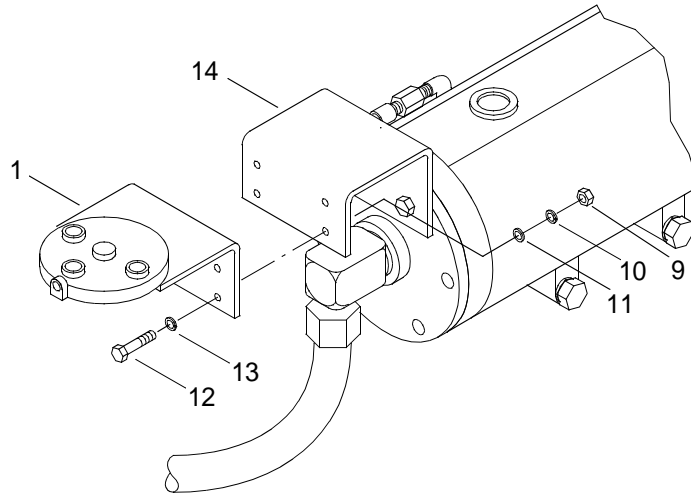

10. Remove four cap screws (12) and flat washers (13) from fuel filter adaptor (1).
11. Remove fuel filter adaptor (1) from mounting bracket (14) and discard.

WARNING**CHEMICAL****EYE PROTECTION**

12. Remove drain pan and dispose of its contents in accordance with local procedure.

INSTALL FUEL FILTER ADAPTOR

1. Install new fuel filter adaptor (1) on mounting bracket (14).

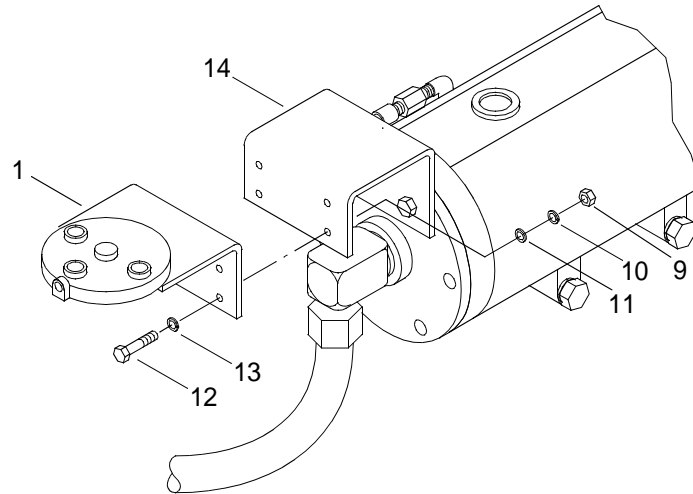

2. Install four cap screws (12) and flat washers (13) on fuel filter adaptor (1).
3. Install four flat washers (11), lock washers (10) and hex nuts (9) on cap screws (12) and flat washers (13).
4. Tighten hex nuts (9).
5. Wrap threads of pipe plug (8) with antiseize tape.

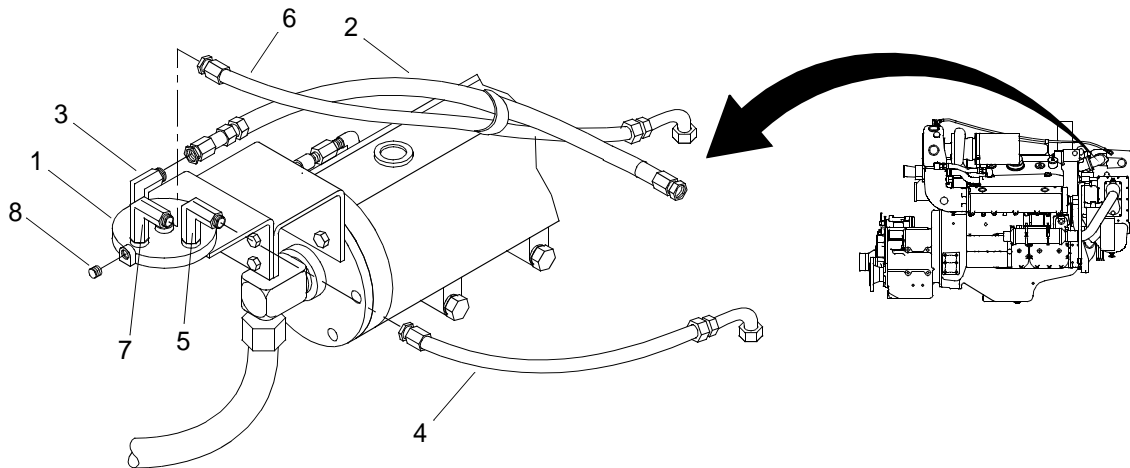

6. Install pipe plug (8) in fuel filter adaptor (1).
7. Tighten pipe plug (8).
8. Wrap both ends of elbow (7) threads with antiseize tape.
9. Install elbow (7) on fuel filter adaptor (1).
10. Tighten elbow (7).
11. Connect fuel line (6) to elbow (7).

12. Tighten fuel line (6).
13. Wrap both ends of elbow (5) threads with antiseize tape.
14. Install elbow (5) on fuel filter adaptor (1).
15. Tighten elbow (5).
16. Connect fuel line (4) on elbow (5).
17. Tighten fuel line (4).
18. Wrap both ends of elbow (3) threads with antiseize tape.
19. Install elbow (3) on fuel filter adaptor (1).
20. Tighten elbow (3).
21. Connect fuel line (2) to elbow (3).
22. Tighten fuel line (2).

WARNING

**CHEMICAL****EYE PROTECTION****SLICK FLOOR**

23. Clean up spilled fluid with a spill kit and dispose of spill kit waste in accordance with local procedure.
24. Install fuel filter cartridge. (WP 0079 00)
25. Perform operational check of diesel engine. (TM 55-1945-205-10-1)

END OF WORK PACKAGE

**UNIT LEVEL MAINTENANCE
CAUSEWAY FERRY
FUEL FILTER MOUNTING BRACKET
REPLACEMENT**

INITIAL SETUP:**Tools**

Tool Kit, General Mechanic's (Rail and Marine) (Item 131, WP 0188 00)

Materials/Parts

Bracket
(72582)
PN 23506219

Personnel Required

Engineer 88L

References

TM 55-1945-205-10-1

Equipment Condition

Fuel Filter Cartridge Removed. (WP 0079 00)

Fuel Filter Adaptor Removed. (WP 0083 00)

REMOVE FUEL FILTER MOUNTING BRACKET

1. Remove two cap screws (1) from mounting bracket (2).

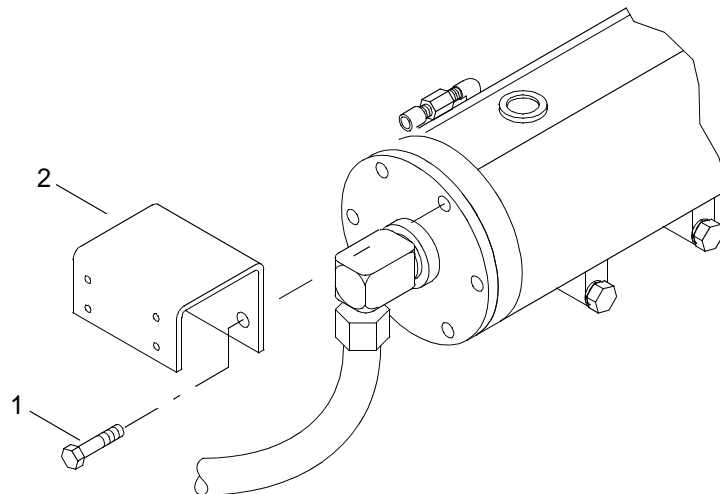

2. Remove bracket (2) from exhaust manifold (3) and discard.

INSTALL FUEL FILTER MOUNTING BRACKET

1. Position new bracket (2) on exhaust manifold (3).
2. Install two cap screws (1) on bracket (2).
3. Tighten cap screws (1).

4. Install fuel filter adaptor. (WP 0083 00)
5. Install fuel filter. (WP 0079 00)
6. Perform operational check of diesel engine. (TM 55-1945-205-10-1)

END OF WORK PACKAGE

**UNIT LEVEL MAINTENANCE
CAUSEWAY FERRY
FUEL ADAPTOR (BLOCK)
REPLACEMENT**

INITIAL SETUP:**Tools**

Tool Kit, General Mechanic's (Rail and Marine) (Item 131, WP 0188 00)
Gloves, Chemical (Item 52, WP 0188 00)
Goggles, Industrial (Item 54, WP 0188 00)
Pan, Drain (Item 87, WP 0188 00)
Wrench, Pipe (Item 136, WP 0188 00)

Materials/Parts

Adaptor
(72582)
PN 25011019
Spill Clean-Up Kit, Hazardous Material (Item 32, WP 0187 00)
Tape, Antiseizing (Item 34, WP 0187 00)

Personnel Required

Engineer 88L

References

TM 55-1945-205-10-1

Equipment Condition

Auto Shutdown System Fuel Oil Pressure Switch Removed. (WP 0179 00)

REMOVE FUEL ADAPTOR (BLOCK)

1. Place a drain pan under fuel system block (1).

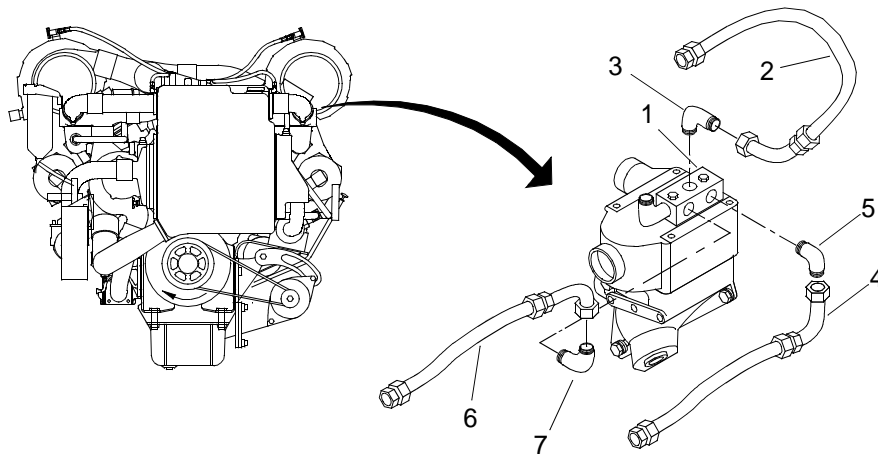

WARNING

**CHEMICAL****EYE PROTECTION**

2. Remove fuel line (2) from elbow (3).

WARNING

**CHEMICAL****EYE PROTECTION**

3. Remove elbow (3) from fuel system block (1).

WARNING

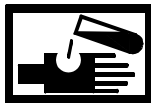
**CHEMICAL****EYE PROTECTION**

4. Remove fuel line (4) from elbow (5).

WARNING

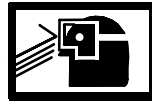
**CHEMICAL****EYE PROTECTION**

5. Remove elbow (5) from fuel system block (1).

WARNING

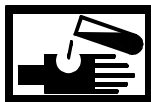
**CHEMICAL****EYE PROTECTION**

6. Remove fuel line (6) from elbow (7).

WARNING**CHEMICAL****EYE PROTECTION**

7. Remove elbow (7) from fuel system block (1).
8. Remove pipe plug (8) from fuel system block (1).

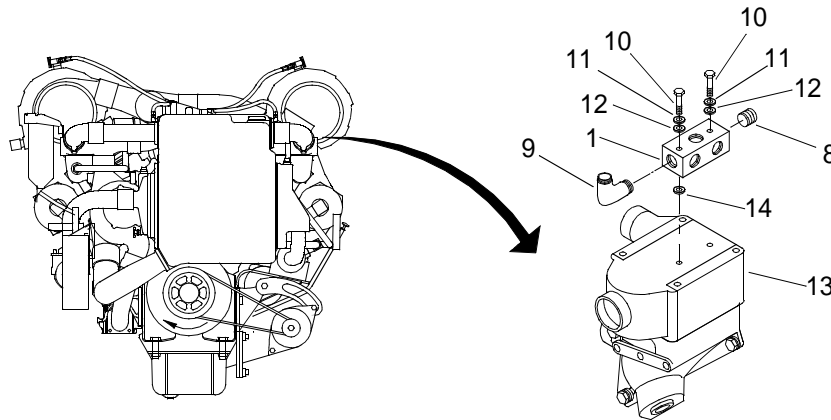

9. Remove auto shutdown system fuel oil pressure switch elbow (9) from fuel system block (1).
10. Remove two cap screws (10), lock washers (11) and flat washers (12) from fuel system block (1).
11. Remove fuel system block (1) from thermostat housing (13) and discard.
12. Remove two spacers (14) and retain for reuse.

WARNING**CHEMICAL****EYE PROTECTION**

13. Remove drain pan and dispose of its contents in accordance with local procedure.

INSTALL FUEL ADAPTOR (BLOCK)

1. Position two spacers (14) on thermostat housing (13).

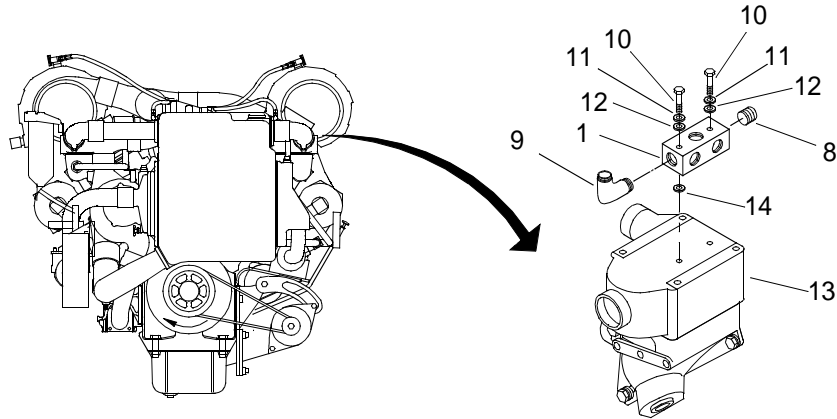

2. Position new fuel system block (1) on thermostat housing (13).
3. Install four cap screws (10), lock washers (11) and flat washers (12) on fuel system block (1).
4. Wrap auto shutdown system fuel oil pressure switch elbow (9) threads with antiseize tape.
5. Install auto shutdown system fuel oil pressure switch elbow (9) on fuel system block (1).
6. Tighten auto shutdown system fuel oil pressure switch elbow (9).
7. Wrap pipe plug (8) threads with antiseize tape.
8. Install pipe plug (8) on fuel system block (1).
9. Tighten pipe plug (8).
10. Wrap both ends of elbow (7) threads with antiseize tape.

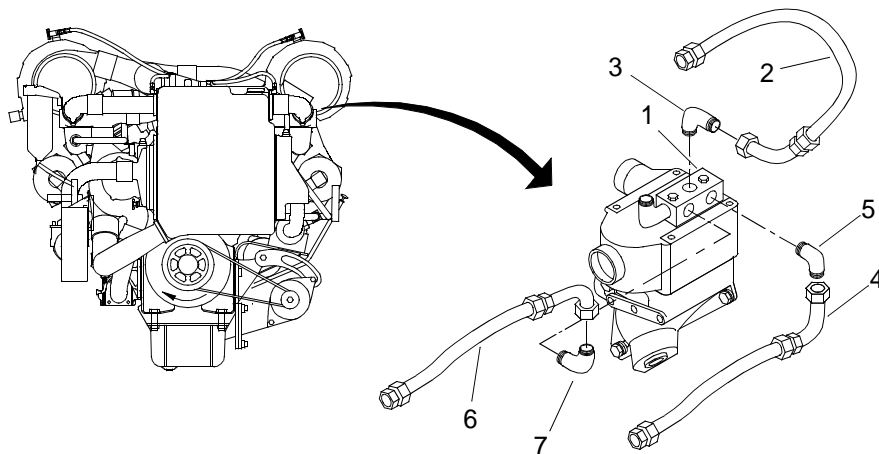

11. Install elbow (7) on fuel system block (1).
12. Tighten elbow (7).

-
13. Install fuel line (6) on elbow (7).
 14. Tighten fuel line (6).
 15. Wrap both ends of elbow (5) threads with antiseize tape.
 16. Install elbow (5) on fuel system block (1).
 17. Tighten elbow (5).
 18. Install fuel line (4) on elbow (5).
 19. Tighten fuel line (4).
 20. Wrap both ends of elbow (3) threads with antiseize tape.
 21. Install elbow (3) on fuel system block (1).
 22. Tighten elbow (3).
 23. Install fuel line (2) on elbow (3).
 24. Tighten fuel line (2).

WARNING

**CHEMICAL****EYE PROTECTION****SLICK FLOOR**

25. Clean up spilled fluid with a spill kit and dispose of spill kit waste in accordance with local procedure.
26. Install auto shutdown system fuel oil pressure switch. (WP 0179 00)
27. Perform operational check of diesel engine. (TM 55-1945-205-10-1)

END OF WORK PACKAGE

**DIRECT SUPPORT MAINTENANCE
CAUSEWAY FERRY
FUEL INJECTOR CONTROL TUBE AND LEVER ASSEMBLY
REMOVAL AND INSTALLATION**

INITIAL SETUP:**Tools**

Tool Kit, General Mechanic's (Item 130, WP 0188 00)
Wrench Set, Socket (3/8 in. sqdr.) (Item 135, WP 0188 00)
Wrench, Torque (10-250 in. lbs) (Item 141, WP 0188 00)

Personnel Required

Engineer 88L

References

TM 55-1945-205-10-1

Equipment Condition

Engine Cool To Touch.
SINCGARS Antenna Removed. (TM 11-5820-890-10-8)
Main Navigation Mast Removed. (TM 55-1945-205-24-3-1)
Intake Plenum Assembly Removed. (TM 55-1945-205-24-3-1)
Operators Cab Removed. (TM 55-1945-205-24-3-1)
Powered Section Engine Hatch Removed. (TM 55-1945-205-24-3-1)
Crankcase Breather Limiter Assembly Removed. (WP 0106 00)
Air Inlet Collector Assembly Removed. (WP 0104 00)
Cylinder Head Poppet Valve Rocker Arm Covers Removed. (WP 0043 00)
Air Intake Housing Removed. (WP 0103 00)
Electronic Governor Actuator Removed. (WP 0098 00)
Electronic Governor Rod Assembly Removed. (WP 0097 00)

REMOVE INJECTOR CONTROL TUBE ASSEMBLY**NOTE**

The procedure is typical for the removal and installation of the fuel system injector control tube and lever assembly on both cylinders and on both the starboard and port engines.

1. Remove cotter pin (1) and clevis pin (2) connecting fuel rod (3) to the injector tube control lever (4).

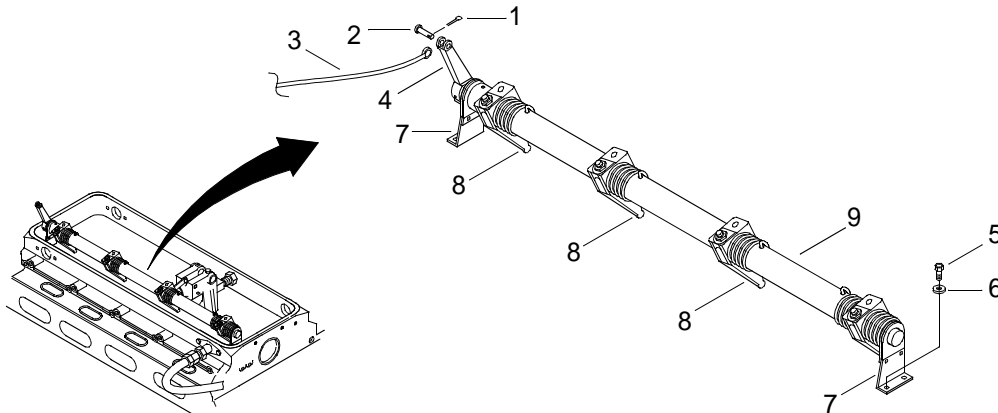

2. Remove two bolts (5) and two lock washers (6) from brackets (7).

3. Disengage rack control levers (8) from injector control racks.
4. Remove injector control tube and lever assembly (9) from cylinder head (10).

INSTALL FUEL CONTROL TUBE ASSEMBLY

1. Align injector control tube and lever assembly (9) with mounting holes in cylinder head (10).
2. Engage rack control levers (8) into injector control racks as the injector control tube and lever assembly (9) is placed on cylinder head (10).
3. Install two bolts (5) and two lock washers (6) in brackets (7) securing injector control tube and lever assembly (9) on cylinder head (10).
4. Using a torque wrench and socket set, torque bolts (5) to 120 - 144 in. lb (14 - 16 N-m).
5. Connect the fuel rod (3) to injector tube control lever (4) with clevis pin (2) and cotter pin (1).
6. Check and adjust fuel modulator settings. (WP 0090 00)
7. Adjust the fuel injector timing. (WP 0092 00)
8. Install air intake housing. (WP 0103 00)
9. Install cylinder head poppet valve rocker arm covers. (WP 0043 00)
10. Install air inlet collector assembly. (WP 0104 00)
11. Install crankcase breather limiter assembly. (WP 0106 00)
12. Install engine hatch. (TM 55-1945-205-24-1-1)
13. Install operators cab. (TM 55-1945-205-24-1-1)
14. Install intake plenum assembly. (TM 55-1945-205-24-1-1)
15. Install main navigation mast. (TM 55-1945-205-24-1-1)
16. Install SINCGARS antenna. (TM 11-5820-890-10-8)
17. Perform operational check of diesel engine. (TM 55-1945-205-10-1)

END OF WORK PACKAGE

**DIRECT SUPPORT MAINTENANCE
CAUSEWAY FERRY
FUEL INJECTOR CONTROL TUBE AND LEVER ASSEMBLY
REPAIR**

INITIAL SETUP:**Tools**

Tool Kit, General Mechanic's (Item 130, WP 0188 00)
 Drill Set, Twist (Item 33, WP 0188 00)
 Drilling Machine, Upright (Item 34, WP 0188 00)
 Press, Arbor, Hand Operated (Item 97, WP 0188 00)
 Gloves, Chemical (Item 52, WP 0188 00)
 Goggles, Industrial (Item 54, WP 0188 00)
 Sheet, Metal (Bar Stock) (Item 117, WP 0188 00)
 Bolt, Machine (Item 15, WP 0188 00)

Materials/Parts

Cleaner (Item 8, WP 0187 00)

Personnel Required

Engineer 88L

DISASSEMBLE FUEL INJECTOR CONTROL TUBE AND LEVER ASSEMBLY**NOTE**

This task is typical for both port and starboard fuel system injector rack assemblies and both port and starboard engines.

1. Loosen lock nut (1) and adjusting screw (2) at each rack control lever (3).

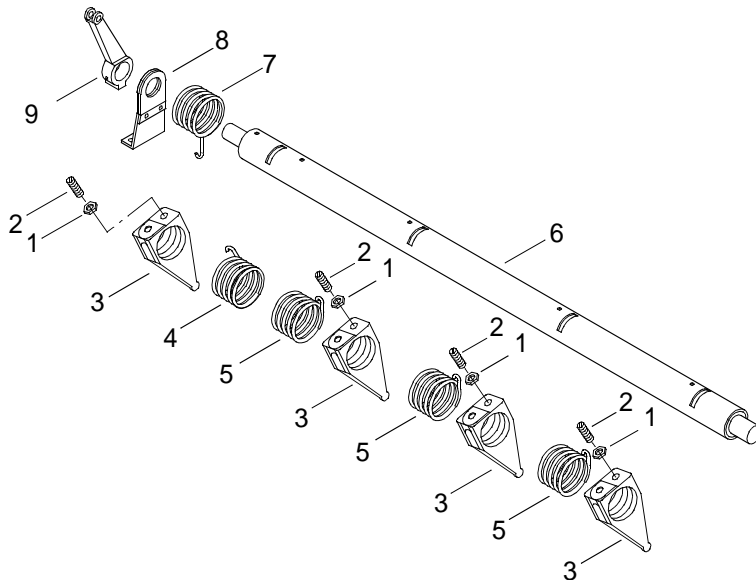

2. Disconnect left hand yield spring (4) and three right hand yield springs (5) at each rack control lever (3).
3. Roll the yield springs (4, 5) out of the slots of injector control tube (6).
4. Disconnect return spring (7) from stationary bracket (8) and injector tube control lever (9).

5. Remove stationary bracket (8) from control tube (6).
6. Remove yield springs (4, 5), return spring (7) and rack control levers (3) from control tube (6).

CLEAN FUEL INJECTOR CONTROL COMPONENTS

WARNING



CHEMICAL



EYE PROTECTION

1. Clean all components of the injector control tube assembly with cleaner.

WARNING



EYE PROTECTION

Do not exceed 40 PSI (279.79kPa) when using compressed air for drying components. Failure to observe this precaution could result in serious injury.

2. Using compressed air, dry all components of the injector control tube assembly thoroughly.

INSPECT FUEL INJECTOR CONTROL COMPONENTS.

NOTE

Repair is limited to the replacement of damaged components.

1. Inspect control tube (6), control lever (9) and rack control levers (3) for excessive wear, scratches, score marks, helix chipping, abrasion and other deterioration. Replace defective parts.
2. Inspect yield springs (4, 5) and return spring (7) for rust and corrosion. Replace defective parts.

INDEX REPLACEMENT CONTROL LEVER TO INJECTOR CONTROL TUBE ASSEMBLY

1. Remove control lever (9) from injector control tube (6) assembly.

- Fabricate an indexing bracket (10) from 5" long piece of 1/2" wide, 1/8" thick bar stock.

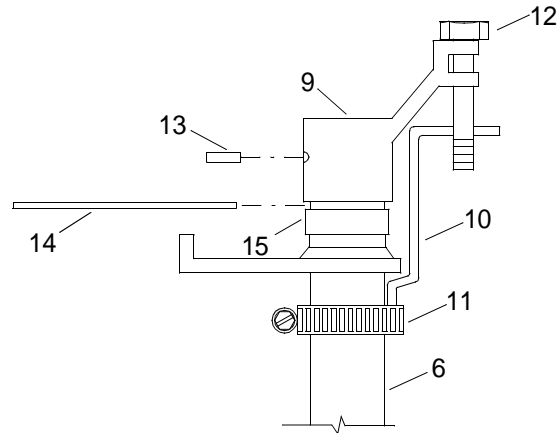

- Secure the indexing bracket (10) to the control tube (6) with a hose clamp (11).
- Insert a 1/4" X 1 3/4" bolt (12) through the end of the control lever (9).
- Rotate the indexing bracket (10) and clamp (11) until the indexing bracket (10) is resting against the bolt (12).

NOTE

Make sure the indexing bracket cannot be moved.

- Tighten the clamp (11) to hold the indexing bracket (10) securely against the bolt (12).
- Install control lever (9) onto injector control tube (6)

NOTE

Before pressing on the control lever, make sure the opposite end of the control tube is supported.

- Remove the pin (13) from the control lever (9) and press the control lever (9) to remove from control tube (6).
- Remove bolt (12) from control lever (9).
- Reinsert the 1/4 in. X. 1 3/4 in. bolt (12) through the end of a control lever (9) and press the control lever (9) onto the control tube (6) with the bolt (12) resting against the indexing bracket (10).
- Place a 0.011 in. (0.028 cm) feeler gage (14) under the control lever (9) to get proper clearance between the control lever (9) and the spacer (15) on the control tube (6).
- Position the control tube (6) on the table of a drill press and drill a 1/8" hole through the control lever (9) approximately 45° from the location of the former hole.
- After drilling, install a pin (13).

ASSEMBLE CYLINDER HEAD INJECTOR CONTROL TUBE AND LEVER ASSEMBLY

1. Install three rack control levers (3), with the levers facing the front bracket (8) position and three right-hand helix yield springs (5) on control tube (6).

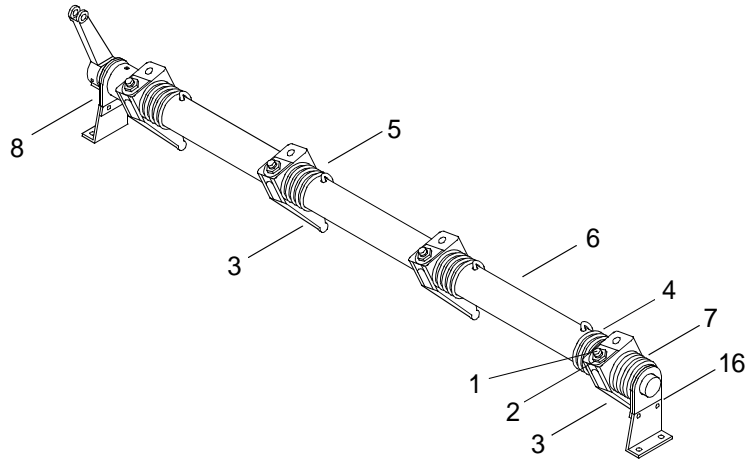

2. Install the odd (left-hand helix) yield spring (4) and a rack control lever (3) with the lever facing the rear bracket (16) position.
3. Attach the curled end of the yield springs (4,5) to the rack control levers (3) and roll the odd, left-hand yield spring (4) into the notch and the right-hand, helix yield springs (5) into the slots in the control tube (6).
4. Turn the four adjusting screws (1) into the notch and slots far enough to position the rack control levers (3) on the control tube (6).
5. Tighten four lock nuts (2).
6. Install control tube return spring (7) and rear bracket (16) on the control tube (6).
7. Attach the curled end of the control tube return spring (7) to the rear rack control lever (3) and the extended end of the return spring (7) behind the rear bracket (16).

END OF WORK PACKAGE

**DIRECT SUPPORT MAINTENANCE
CAUSEWAY FERRY
FUEL IGNITION MODULATOR ASSEMBLY
REMOVAL AND INSTALLATION**

INITIAL SETUP:**Tools**

Tool Kit, General Mechanic's (Item 130, WP 0188 00)
 Gloves, Chemical (Item 52, WP 0188 00)
 Goggles, Industrial (Item 54, WP 0188 00)
 Wrench Set, Socket (3/8 in. sqdr.) (Item 135, WP 0188 00)
 Wrench, Torque (10-250 in. lbs) (Item 141, WP 0188 00)

Personnel Required

Engineer 88L

References

TM 55-1945-205-10-1

Equipment Condition

SINGARS Antenna Removed. (TM 11-5820-890-10-8)
 Main Navigation Mast Removed. (TM 55-1945-205-24-3-1)
 Intake Plenum Assembly Removed. (TM 55-1945-205-24-3-1)
 Operators Cab Removed. (TM 55-1945-205-24-3-1)
 Powered Section Engine Hatch Removed. (TM 55-1945-205-24-3-1)
 Engine Cool To Touch.
 Crankcase Breather Limiter Assembly Removed. (WP 0106 00)
 Air Inlet Collector Assembly Removed. (WP 0104 00)
 Cylinder Head Poppet Valve Rocker Arm Covers Removed. (WP 0043 00)
 Fuel Manifolds Removed. (WP 0050 00)

REMOVE FUEL IGNITION MODULATOR ASSEMBLY**NOTE**

The following task is typical for the removal and installation of fuel ignition modulator assemblies in both port and starboard engines.

The fuel modulator is located on the port (left) cylinder head between cylinders 3 and 4.

1. Disconnect air supply tube (1) from elbow (2).

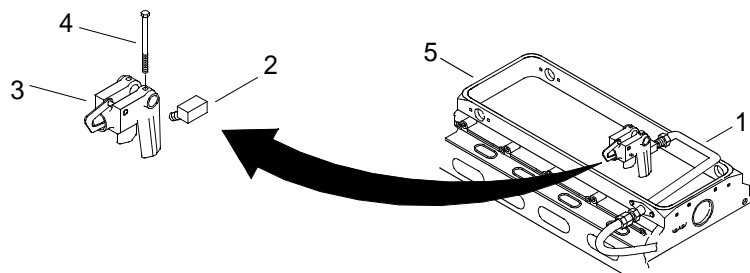

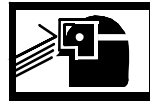
WARNING**CHEMICAL****EYE PROTECTION**

- Remove elbow (2) from fuel modulator (3).

WARNING**CHEMICAL****EYE PROTECTION**

- Remove two bolts (4) from fuel modulator (3).

WARNING**CHEMICAL****EYE PROTECTION**

- Remove fuel modulator (3) from cylinder head (5).
- Remove cap screw (6) and washer (7) from lever (8).

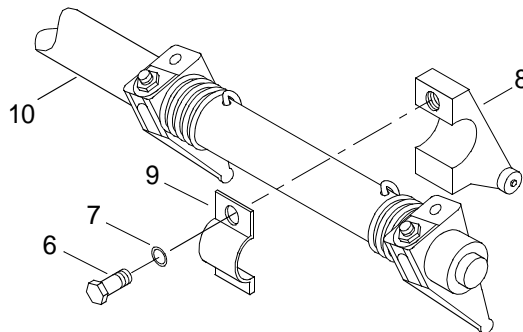

- Remove lever (8) and clamp (9) from control tube (10).

INSTALL FUEL IGNITION MODULATOR ASSEMBLY

- Install lever (8) and clamp (9) on control tube (10).
- Install cap screw (6) and washer (7) securing lever (8) to control tube (10).
- Using torque wrench and socket set, torque cap screws (6) to 120 - 144 in. lb (14 to 16 N-m).

4. Position fuel modulator (3) on cylinder head (5).

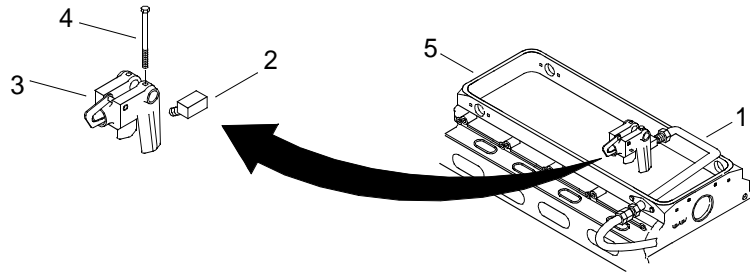

5. Install two cap screws (4), to secure modulator (3) on cylinder head (5).
6. Tighten cap screws (4).
7. Install elbow (2) onto modulator (3).
8. Connect air supply tube (1) to elbow (2).
9. Install fuel manifolds. (WP 0050 00)
10. Install cylinder head poppet valve rocker arm covers. (WP 0043 00)
11. Adjust fuel ignition modulator. (WP 0090 00)
12. Install air inlet collector assembly. (WP 0104 00)
13. Install crankcase breather limiter assembly. (WP 0106 00)
14. Install powered section engine hatch. (TM 55-1945-205-24-1-1)
15. Install operators cab. (TM 55-1945-205-24-1-1)
16. Install intake plenum assembly. (TM 55-1945-205-24-1-1)
17. Install main navigation mast. (TM 55-1945-205-24-1-1)
18. Install SINGARS antenna. (TM 11-5820-890-10-8)
19. Perform operational check of diesel engine. (TM 55-1945-205-10-1)

END OF WORK PACKAGE

**GENERAL SUPPORT MAINTENANCE
CAUSEWAY FERRY
FUEL IGNITION MODULATOR ASSEMBLY
REPAIR**

INITIAL SETUP:**Tools**

Tool Kit, General Mechanic's (Item 130, WP 0188 00)
Gloves, Chemical (Item 52, WP 0188 00)
Goggles, Industrial (Item 54, WP 0188 00)

Materials/Parts

Cleaner (Item 8, WP 0187 00)

Personnel Required

Engineer 88L

DISASSEMBLE FUEL MODULATOR ASSEMBLY

1. Remove cam pivot pin (1) from top of modulator housing (2).

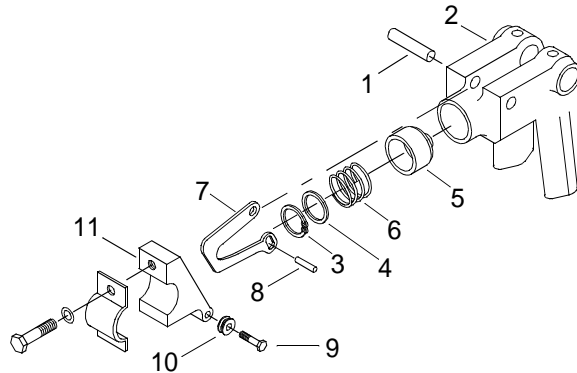

2. Remove retainer (3), ring (4), piston (5), spring (6) and cam (7) from modulator housing assembly (2).
3. Remove piston pin (8) connecting the cam (7) to piston (5).
4. Remove retainer (3), ring (4), piston (5), and spring (6) from cam (7).
5. Remove pin (9) and roller (10) from lever assembly (11).

CLEAN FUEL MODULATOR ASSEMBLY

WARNING



CHEMICAL



EYE PROTECTION

1. Using cleaner, clean the exterior and cylinder bore of the fuel modulator housing (2).

WARNING

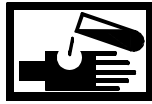
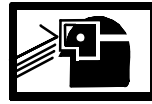
**CHEMICAL****EYE PROTECTION**

- Using cleaner, clean the modulator assembly components.

WARNING

**EYE PROTECTION**

Do not exceed 40 PSI (279.79 kPa) when using compressed air for drying components. All personnel must wear safety goggles during this procedure. Failure to observe this precaution could result in serious injury.

- Using compressed air, dry parts.

INSPECT FUEL MODULATOR ASSEMBLY

- Inspect piston (5) outer diameter for wear and score marks. Replace defective parts.
- Inspect cylinder bore of fuel modulator housing (2) for wear and score marks. Replace defective parts.
- Inspect the operating surfaces of the cam (7), roller (10), pin (8), pin (1) and pin (9) for wear. Replace defective parts.

ASSEMBLE FUEL MODULATOR ASSEMBLY

- Install pin (9) and roller (10) onto lever (11).
- Install spring (6), ring (4), retainer (3), and piston (5) on cam (7).
- Install piston pin (8) connecting cam (7) to piston (5).
- Install cam assembly (7) into fuel modulator housing (2).
- Install cam pivot pin (1) at top of modulator (2).

END OF WORK PACKAGE

**DIRECT SUPPORT MAINTENANCE
CAUSEWAY FERRY
FUEL IGNITION MODULATOR ASSEMBLY
ADJUSTMENT**

INITIAL SETUP:**Tools**

Tool Kit, General Mechanic's (Item 130, WP 0188 00)
Gage, Injector Rack (Item 47, WP 0188 00)

Personnel Required

Engineer 88L

References

TM 55-1945-205-10-1

Equipment Condition

SINGGARS Antenna Removed. (TM 11-5820-890-10-8)
Main Navigation Mast Removed. (TM 55-1945-205-24-3-1)
Intake Plenum Assembly Removed. (TM 55-1945-205-24-3-1)
Operators Cab Removed. (TM 55-1945-205-24-3-1)
Powered Section Engine Hatch Removed. (TM 55-1945-205-24-3-1)
Engine Cool To Touch.
Air Intake Housing Removed. (WP 0103 00)
Crankcase Breather Limiter Assembly Removed. (WP 0106 00)
Air Inlet Collector Assembly Removed. (WP 0104 00)
Electronic Governor Rod Removed. (WP 0097 00)
Electronic Governor Actuator Removed. (WP 0098 00)
Cylinder Head Poppet Valve Rocker Arm Covers Removed. (WP 0043 00)

ADJUST FUEL IGNITION MODULATOR ASSEMBLY**NOTE**

Before attempting to adjust the fuel modulator and rack control levers, the fuel modulator lever and roller assembly must be free of cam contact.

For this procedure, use the fuel injector next to, and forward of, the fuel modulator assembly.

1. Loosen clamp screw (1) to ensure that the fuel modulator lever (2) and roller (3) assembly are not in contact with the cam. (4).

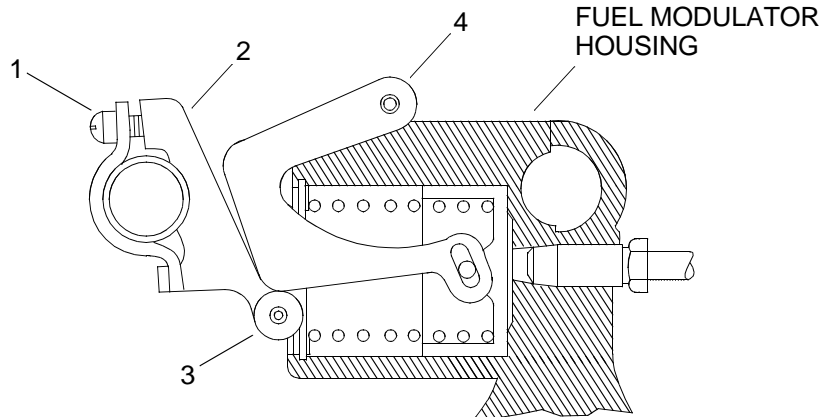

2. With the engine stopped, insert a 0.454 in. (1.15 cm) injector rack gage between the injector body (5) rack recess and the shoulder on the injector rack (6).

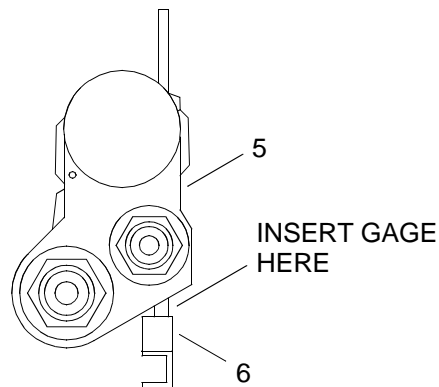

NOTE

The injector rack gage must stand up while being held in place by the rack.

3. Verify that the handle of the injector rack gage is at a 45° angle.
4. Hold the run/stop lever in the run position.
5. With the clamp screw (1) loose, push the fuel modulator lever (2) and roller assembly (3) until the roller (3) contacts the cam (4) with enough force to take up the clearances between the roller (3) and cam pin.

6. Insert a 3/8 in. x 3 in. x 0.017 in. (0.043 cm) feeler gage between the cam (4) and the roller (3).

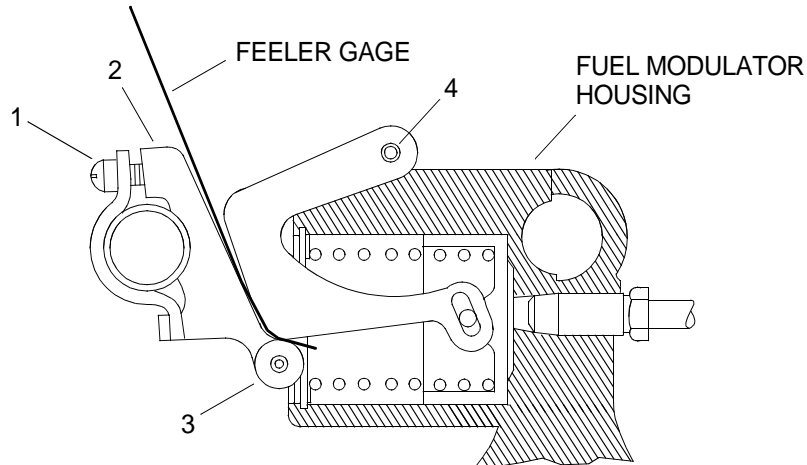

7. Verify that the cam (4) is centered.
8. Tighten clamp screw (1) until the feeler gage falls.
9. Replace the 0.017 in. (0.043 cm) feeler gage with a 0.004 in. (0.010 cm) thick feeler gage.
10. Tighten the clamp screw (1) until the feeler gage falls again.
11. Hold the governor in the maximum speed position.
12. Check that the 0.004 in. (0.010 cm) injector rack gage stands at a 45° angle by itself.
13. Remove the 0.004 in. (0.010 cm) feeler gage.
14. Insert a 0.005 in. (0.013 cm) thick feeler gage between the roller (3) and the cam (4). If the 0.005 in. (0.013 cm) injector rack gage falls, the setting is correct.
15. Remove the 0.005 in. (0.013 cm) feeler gage.
16. Install cylinder head poppet valve rocker arm covers. (WP 0043 00)
17. Install electronic governor actuator. (WP 0098 00)
18. Install electronic governor rod. (WP 0097 00)
19. Install air inlet collector assembly. (WP 0104 00)
20. Install crankcase breather limiter assembly. (WP 0106 00)
21. Install air intake housing. (WP 0103 00)
22. Install powered section engine hatch. (TM 55-1945-205-24-1-1)
23. Install operators cab. (TM 55-1945-205-24-1-1)

24. Install intake plenum assembly. (TM 55-1945-205-24-1-1)
25. Install main navigation mast. (TM 55-1945-205-24-1-1)
26. Install SINGARS antenna. (TM 11-5820-890-10-8)
27. Perform operational checks. (TM 55-1945-205-10-1)

END OF WORK PACKAGE

**DIRECT SUPPORT MAINTENANCE
CAUSEWAY FERRY
FUEL INJECTOR ASSEMBLY
REMOVAL, CLEANING, INSPECTION AND INSTALLATION**

INITIAL SETUP:**Tools**

Tool Kit, General Mechanic's (Item 130, WP 0188 00)
Reamer, Hand (Item 102, WP 0188 00)
Wrench, Torque (150-750 in. lbs) (Item 142, WP 0188 00)
Wrench Set, Socket (3/8 in. sqdr.) (Item 135, WP 0188 00)
Apron, Utility (Item 8, WP 0188 00)
Gloves, Chemical (Item 52, WP 0188 00)
Goggles, Industrial (Item 54, WP 0188 00)
Compressor Unit, Reciprocating, Power Drive (Item 27, WP 0188 00)
Hose Assembly, Non-metallic (Item 66, WP 0188 00)

Materials/Parts

Cloth, Cleaning (Item 13, WP 0187 00)
Cleaner (Item 8, WP 0187 00)
Fuel, Diesel (Item 19, WP 0187 00)
Grease, Automotive and Artillery (Item 20, WP 0187 00)

Personnel Required

Engineer 88L

References

TM 55-1945-205-10-1

Equipment Condition

Engine Cool To Touch.
SINCGARS Antenna Removed. (TM 11-5820-890-10-8)
Main Navigation Mast Removed. (TM 55-1945-205-24-1-1)
Intake Plenum Assembly Removed. (TM 55-1945-205-24-1-1)
Operators Cab Removed. (TM 55-1945-205-24-1-1)
Powered Section Engine Hatch Removed. (TM 55-1945-205-24-1-1)
Crankcase Breather Limiter Assembly Removed. (WP 0106 00)
Air Inlet Collector Assembly Removed. (WP 0104 00)
Cylinder Head Poppet Valve Rocker Arm Covers Removed. (WP 0043 00)
Fuel Manifolds Removed. (WP 0050 00)
Cylinder Head Poppet Valve Rocker Arms Removed. (WP 0048 00)

REMOVE FUEL INJECTOR ASSEMBLY**NOTE**

This procedure is typical for removal and installation of all injectors in both the port and starboard engines.

1. Loosen retaining nut (1) and injector control rack lever adjusting screw (2).

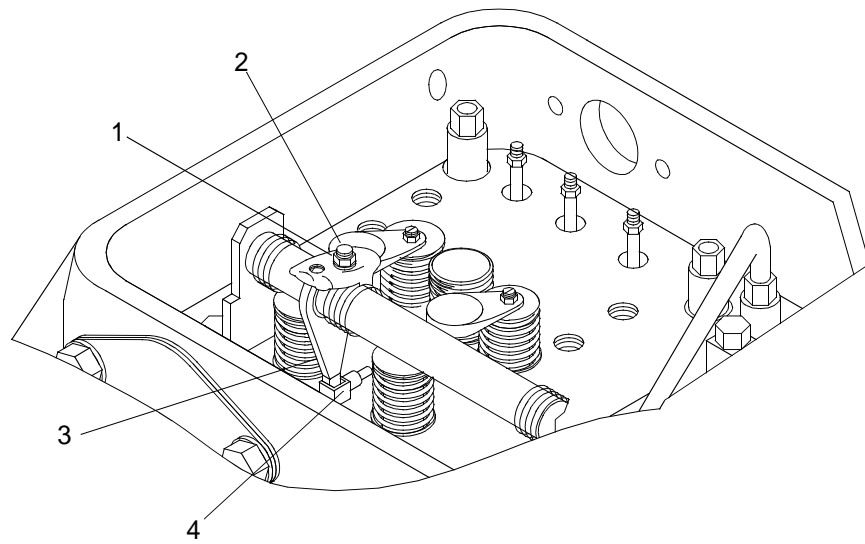

2. Slide injector control rack lever (3) away from injector control rack (4).
3. Mark and remove cap screw (5), washer (6) and clamp (7).

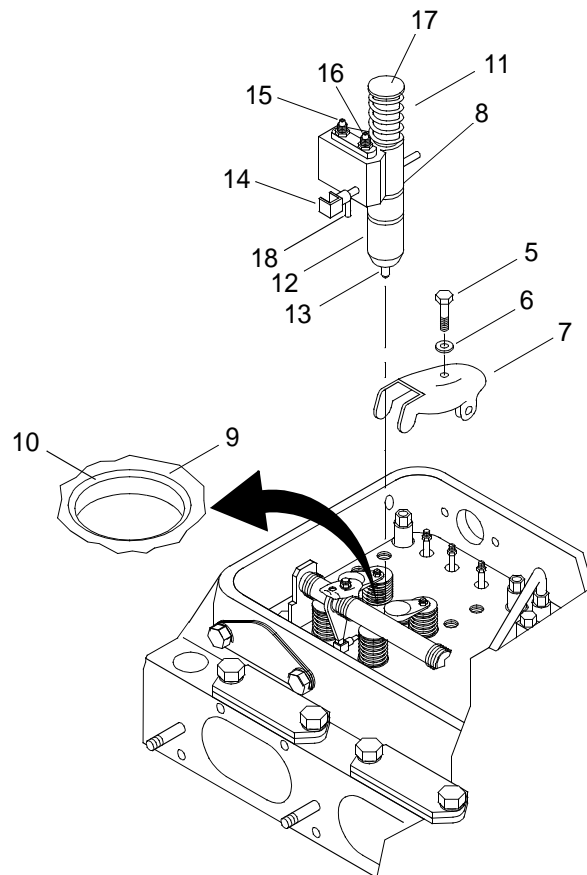

4. Remove injector (8).

CAUTION

Cylinder head injector hole must be covered to keep out foreign matter.

- Cover injector hole (9) with clean, lint free cloth.

CLEAN FUEL INJECTOR ASSEMBLY

WARNING

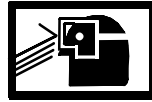
CHEMICAL

EYE PROTECTION

- Clean exterior surface of injector (8) with cleaner.

WARNING

EYE PROTECTION

Do not exceed 40 psi when using compressed air for drying components. Failure to comply could result in injury to personnel.

- Dry injector using compressed air.

WARNING

CHEMICAL

EYE PROTECTION

- Pack reamer with grease.
- Remove any carbon deposits from cylinder head injector tube beveled seat (10) using injector tube bevel reamer or equivalent.

INSPECT FUEL INJECTOR ASSEMBLY

- Inspect injector follower spring (11) for rust and corrosion. If found, replace fuel injector.
- Inspect injector follower spring (11) for wear, scratches, score marks, helix chipping, abrasion and deterioration. If found, replace fuel injector.
- Inspect injector body (12) for wear, scratches, score marks, helix chipping, abrasion and deterioration. If found, replace fuel injector.
- Inspect injector spray tip (13) for carbon build-up, rust and corrosion. If found, replace fuel injector.

5. Inspect injector spray tip (13) for wear, scratches score marks, helix chipping, abrasion and deterioration. If found, replace fuel injector.
6. Inspect injector rack (14) for wear, scratches score marks, helix chipping, abrasion and deterioration. Replace defective parts. (WP 0086 00)
7. Inspect injector filler caps and nuts (15 and 16) for rust and corrosion. If found, replace fuel injector.
8. Inspect top of injector follower (17) for rust and corrosion. If found, replace fuel injector.
9. Inspect top of injector follower (17) for wear, scratches, core marks, helix chipping, abrasion and deterioration. If found, replace fuel injector.
10. Inspect injector body (12) for wear, scratches, score marks, helix chipping, abrasion and deterioration. If found, replace fuel injector.

INSTALL FUEL INJECTOR ASSEMBLY

WARNING



CHEMICAL



EYE PROTECTION

1. Add diesel fuel to fuel inlet filter cap (16), until it runs out of outlet filter cap (15).
2. Using lint free cloth, wipe excess fuel from injector.
3. Remove cover from injector tube hole (9).
4. Align dowel pin (18) with cylinder head locating hole.
5. Install injector (8) into injector tube hole (9).
6. Slide injector rack control lever (3) into injector control rack (4).

CAUTION

Make sure clamp does not interfere with injector follower spring or exhaust valve spring.

7. Install clamp (7), bolt (5) and convex washer (6) securing injector (8).

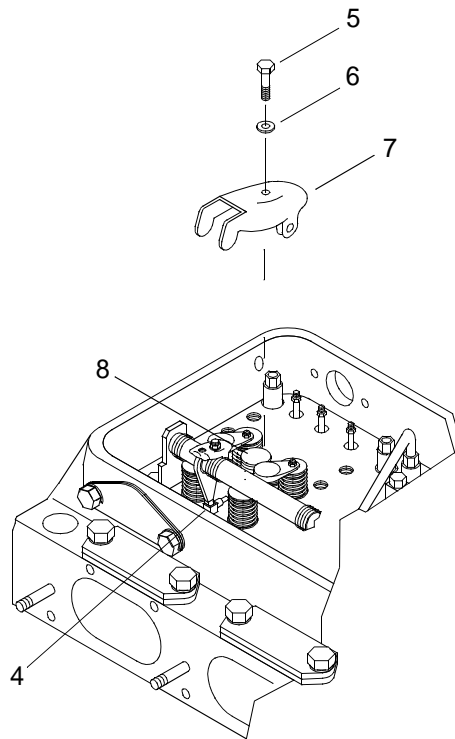

8. Using torque wrench and socket set, torque bolt (5) to 240 - 300 in. lbs (27-34 N-m).
9. Check injector control rack (4) for free movement. If injector control rack is sticking or binding, loosen bolt (5).
10. Using torque wrench and socket set, torque bolt (5) to 240 - 300 in. lbs (27-34 N-m).
11. Prime fuel system. (WP 0077 00)
12. Install cylinder head poppet valve rocker arms. (WP 0048 00)
13. Start engine. (TM 55-1945-205-10-1)
14. Check fuel injector lines for leaks.
15. Install fuel manifolds. (WP 0050 00)
16. Install cylinder head poppet valve rocker arm covers. (WP 0043 00)
17. Install air inlet collector assembly. (WP 0104 00)
18. Install crankcase breather limiter assembly. (WP 0106 00)
19. Install powered section engineer hatch. (TM 55-1945-205-24-1-1)
20. Install operators cab. (TM 55-1945-205-24-1-1)
21. Install intake plenum assembly. (TM 55-1945-205-24-1-1)

22. Install main navigation mast. (TM 55-1945-205-24-1-1)

23. Install SINCGARS antenna. (TM 11-5820-890-10-8)

24. Perform operational check of diesel engine. (TM 55-1945-205-10-1)

END OF WORK PACKAGE

**DIRECT SUPPORT MAINTENANCE
CAUSEWAY FERRY
FUEL INJECTOR TIMING
ADJUSTMENT**

INITIAL SETUP:**Tools**

Tool Kit, General Mechanic's (Item 130, WP 0188 00)
Gage, Injector Timing (Item 48, WP 0188 00)

Personnel Required

Engineer 88L (2)

References

TM 55-1945-205-10-1

Equipment Condition

Engine Cool To Touch.
SINCGARS Antenna Removed. (TM 11-5820-890-10-8)
Main Navigation Mast Removed. (TM 55-1945-205-24-1-1)
Intake Plenum Assembly Removed. (TM 55-1945-205-24-1-1)
Operators Cab Removed. (TM 55-1945-205-24-1-1)
Powered Section Engine Hatch Removed. (TM 55-1945-205-24-1-1)
Crankcase Breather Limiter Assembly Removed. (WP 0106 00)
Air Inlet Collector Assembly Removed. (WP 0104 00)
Air Intake Housing Assembly Removed. (WP 0103 00)
Cylinder Head Poppet Valve Rocker Arm Cover Removed. (WP 0043 00)

ADJUST FUEL INJECTOR TIMING**NOTE**

This task is typical for all injectors on both port and starboard engines.

The no fuel position can be obtained by fully rotating the fuel rod clevis away from the electronic governor actuator.

1. The first engineer will rotate the crank shaft (1) clockwise while the second engineer holds the fuel rod clevis (2) in the no-fuel position.

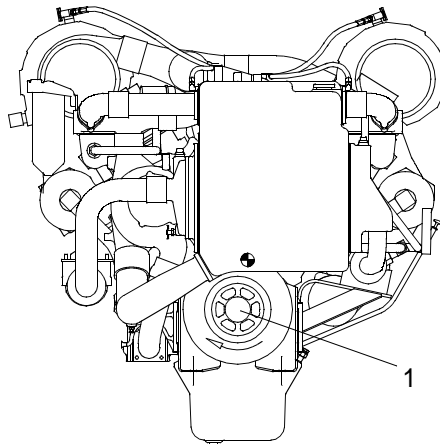

- The second engineer will tell the first engineer when the exhaust valves (3) are in the full open position.

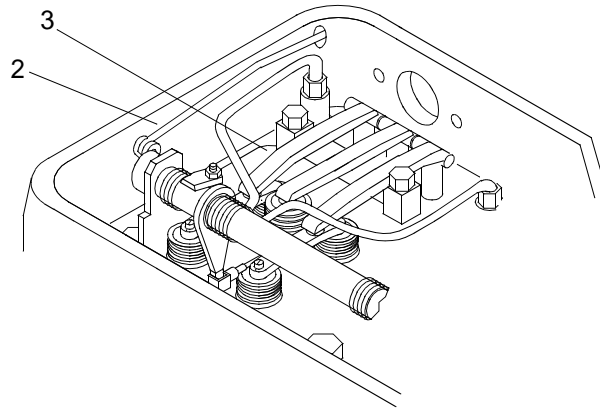

NOTE

The flat side of the injector gage needs to face the injector follower.

- Insert the injector gage in the timing hole at the top of the injector (4).

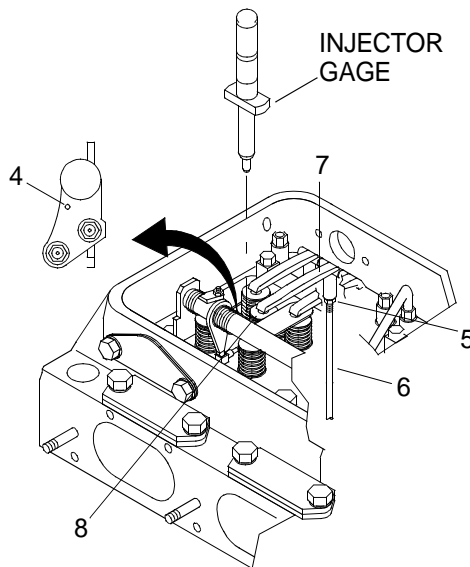

- Loosen lock nut (5) on the injector rocker arm push rod (6).
- Rotate push rod (6) to adjust rocker arm (7) until the flat side of the gage moves just over the top of the injector follower (8).
- Remove the injector gage and tighten lock nut (5) while securing push rod (6).
- Using the injector gage, verify the timing.
- Adjust the timing on the remaining seven fuel injectors (9) in the same manner.
- Install cylinder head poppet valve rocker arm cover. (WP 0043 00)
- Install air inlet collector assembly. (WP 0104 00)

-
11. Install crankcase breather limiter assembly. (WP 0106 00)
 12. Install air intake housing. (WP 0103 00)
 13. Install powered section engine hatch. (TM 55-1945-205-24-1-1)
 14. Install operators cab. (TM 55-1945-205-24-1-1)
 15. Install intake plenum assembly. (TM 55-1945-205-24-1-1)
 16. Install main navigation mast. (TM 55-1945-205-24-1-1)
 17. Install SINGARS antenna. (TM 11-5820-890-10-8)
 18. Perform operational checks. (TM 55-1945-205-10-1)

END OF WORK PACKAGE

**DIRECT SUPPORT MAINTENANCE
CAUSEWAY FERRY
FUEL INJECTOR RACK CONTROL LEVER
ADJUSTMENT**

INITIAL SETUP:**Tools**

Tool Kit, General Mechanic's (Item 130, WP 0188 00)
Wrench, Torque (10-250 in. lbs) (Item 141, WP 0188 00)
Crowfoot Attachment, Socket Wrench 3/8 in. sqdr (Item 31, WP 0188 00)

Materials/Parts

Pin, Cotter
(80205)
NSN 5315-00-839-2325
PN MS24668-132
Qty 8

Personnel Required

Engineer 88L (2)

References

TM 55-1945-205-10-1

Equipment Condition

SINGARS Antenna Removed. (TM 11-5820-890-10-8)
Main Navigation Mast Removed. (TM 55-1945-205-24-1-1)
Intake Plenum Assembly Removed. (TM 55-1945-205-24-1-1)
Operators Cab Removed. (TM 55-1945-205-24-1-1)
Powered Section Engine Hatch Removed. (TM 55-1945-205-24-1-1)
Crankcase Breather Limiter Assembly Removed. (WP 0106 00)
Emergency Stop Solenoid Removed. (WP 0176 00)
Air Inlet Collector Assembly Removed. (WP 0104 00)
Cylinder Head Poppet Valve Rocker Cover Removed. (WP 0043 00)
Electronic Governor Rod Assembly Removed. (WP 0097 00)
Fuel Injector Timing Adjusted. (WP 0092 00)

ADJUST INJECTOR RACK CONTROL LEVER**NOTE**

This task is typical for injectors on both port and starboard engines. The cylinder banks are identified as right and left as viewed from the rear of the engine.

It is necessary to set a baseline to use for adjusting all of the injector rack control levers. This baseline will be set on the first cylinder of the left bank. The first cylinder of the right bank will be set next so it balances with the left cylinder. Once these baseline adjustments are completed, there will be no further adjustment to the number one cylinders of the left and right bank. The remaining cylinders will be set, left and right, using the first cylinder, left bank as a guide.

1. Verify fuel supply and return valves (1) are closed.

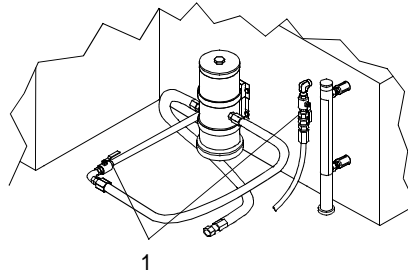

- Loosen four lock nuts (2) and screws (3) on left cylinder bank (4).

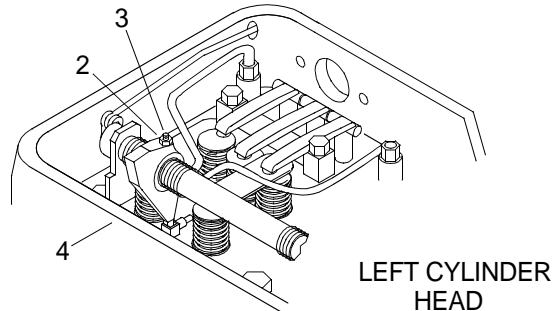

- On the right cylinder bank (5), remove cotter pin (6) and clevis pin (7).

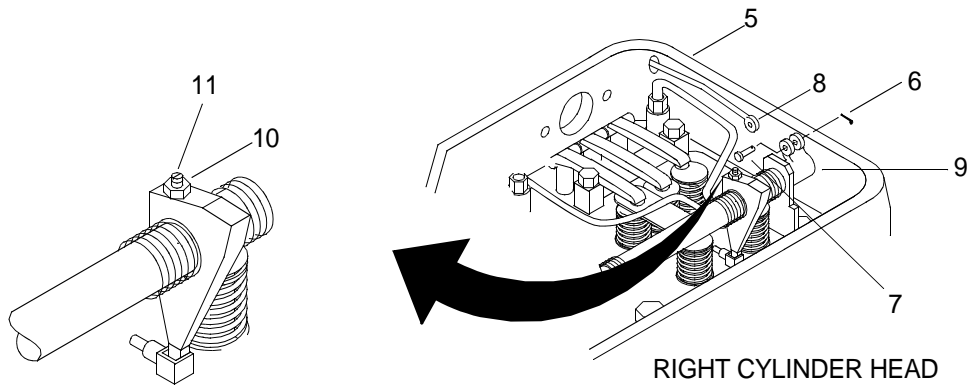

- Disconnect fuel rod (8) from clevis lever (9).
- Loosen four lock nuts (10) and screws (11) on the injectors of the right cylinder bank (5).

NOTE

The full fuel position is reached when the injector rack is completely in.

- The first engineer pulls the throttle control arm (12) to the full fuel position and holds the control arm with light pressure.

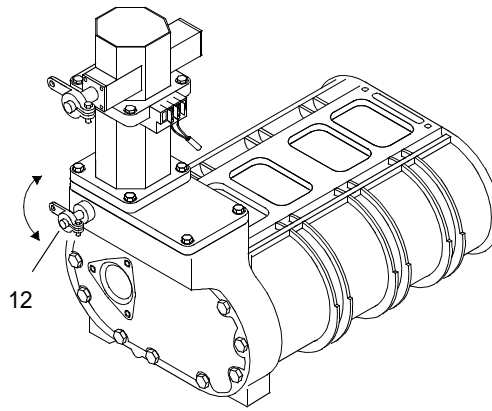

CAUTION

Do not overtighten injector rack control lever adjusting screws. Failure to comply can damage injector rack control tube.

7. The second engineer then tightens the adjusting screw (3) of the left cylinder bank (4), until the injector rack (13) starts to rotate slightly, or until increased resistance is felt while tightening.

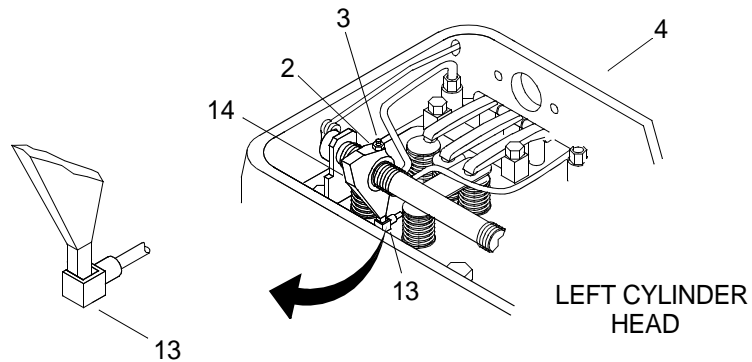

8. Tighten the adjusting screw (3) an additional $\frac{1}{8}$ turn.
9. Tighten lock nut (2).

NOTE

The injector rack control lever adjustment must be verified with the throttle control arm in the full fuel position.

10. Verify the adjustment of the injector rack control lever (14) is not too loose.
 - a. Press downward and observe injector rack (13) for downward rotation.
 - b. Release pressure and observe injector rack (13) to see that it returned to its original position.
 - c. If it does not return to the original position, loosen lock nut (2).
 - d. Tighten adjusting screw (3) slightly.
 - e. Tighten lock nut (2) and verify adjustment again. Repeat this step until adjustment is correct.
11. Verify the adjustment of the control lever (14) is not too tight.

- a. The first engineer returns the throttle control arm (12) to idle position.
- b. The second engineer observes the injector control rack (13).

NOTE

If the injector rack reaches the limit of its downward rotation before the throttle arm is at full fuel position, the adjustment is too tight.

- c. The first engineer slowly moves the throttle arm (12) from idle to full fuel position.
- d. Loosen lock nut (2).
- e. Loosen adjusting screw (3) slightly.
- f. Tighten lock nut (2) and verify adjustment again. Repeat this step until adjustment is correct.

NOTE

When using a torque wrench to obtain desired torque of the lock nut and maintain the position of the adjusting screw, it will be necessary to use a crowfoot attachment. When using an adaptor, refer to the torque limits work package (WP 0182 00) for adaptor formula to calculate the applied torque.

12. While hold the adjusting screw (3) steady, use a torque wrench and crowfoot attachment to torque lock nut (2) to 24 - 35 in. lbs (2.7 - 3.9 N-m).
13. On the left cylinder bank (4), remove the cotter pin (15) and clevis pin (16).

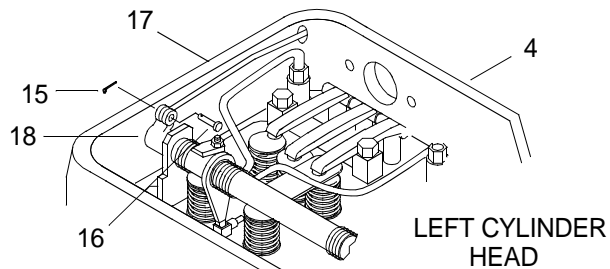

14. Disconnect the fuel rod (17) from the clevis lever (18).
15. On the right cylinder bank (5), install the fuel rod (8) in the clevis lever (9).
16. Install the clevis pin (7) through the clevis lever (9).
17. Install the cotter pin (6) through the clevis pin (7).

NOTE

The full fuel position is reached when the injector lever is completely in the injector rack.

18. The first soldier pulls the throttle control arm (12) to the full fuel position and holds the control arm with light pressure.

CAUTION

Do not overtighten injector rack control lever adjusting screws. Failure to comply can damage injector rack control tube.

19. The second soldier then tightens the adjusting screw (11) of the right cylinder bank (5), until the injector rack (19) starts to rotate slightly, or until increased resistance is felt.

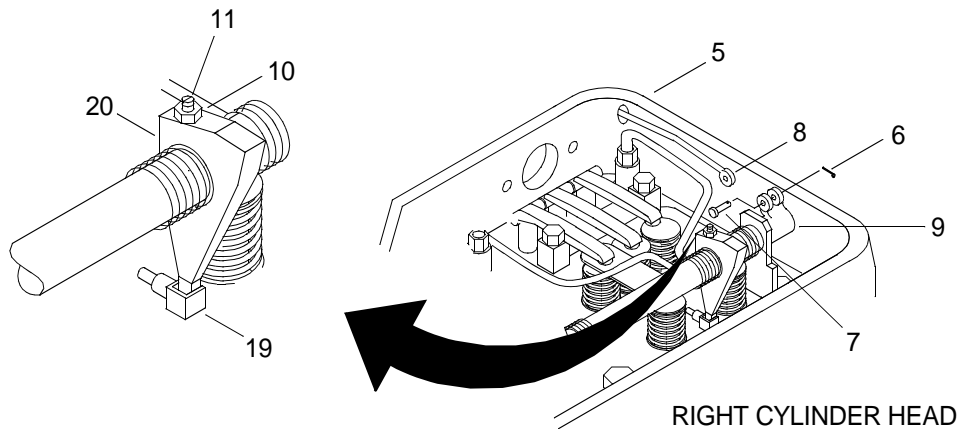

20. Tighten the adjusting screw (11) an additional $\frac{1}{8}$ turn.
21. Tighten lock nut (10).

NOTE

The injector rack control lever adjustment must be verified with the throttle control arm in the full fuel position.

22. Verify the adjustment of the injector rack control lever (20) is not too loose.
 - a. Press downward and observe injector rack (13) for downward rotation.
 - b. Release Pressure and observe injector rack (13) to see that it returned to its original Position.
 - c. If it does not return to the original position, loosen lock nut (10).
 - d. Tighten adjusting screw (11) slightly.
 - e. Tighten lock nut (10).
23. Verify the adjustment of the injector rack control lever (20) is not too tight.
 - a. The first soldier returns the throttle control arm (12) to idle position.
 - b. The second soldier observes the injector control rack (19).

- c. The first soldier slowly moves the throttle arm (12) from idle to full fuel position.
- d. If the injector control rack (19) reaches the limit of its downward rotation before the throttle arm (12) is at full fuel position, the adjustment is too tight.
- e. Loosen lock nut (10).
- f. Loosen adjusting screw (11) slightly.
- g. Tighten lock nut (10) and verify adjustment again. Repeat this step until adjustment is correct.

NOTE

When using a torque wrench to obtain desired torque of the lock nut and maintain the position of the adjusting screw, it will be necessary to use a crowfoot attachment. When using an adaptor, refer to the torque limits work package (WP 0182 00) for adaptor formula to calculate the applied torque.

24. While holding the adjusting screw (11) steady, use a torque wrench and crowfoot adaptor to torque lock nut (10) to 24 - 35 in. lbs (2.7 - 3.9 N-m).
25. The first soldier returns the throttle arm (12) to the idle position.
26. On the left cylinder bank (4), install fuel rod (17) into clevis lever (18) with clevis pin (16) and cotter pin (15).

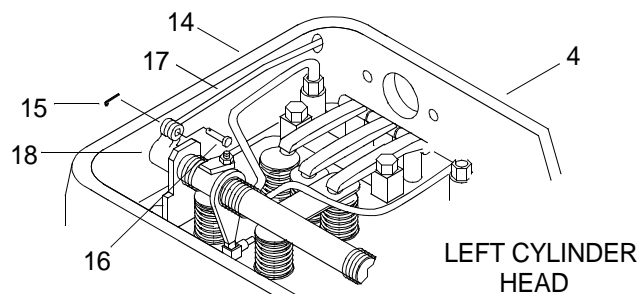

27. The first soldier slowly moves the throttle control arm (12) to the full fuel position while the second soldier observes the movement of the fuel rods (8 and 17) in both cylinder banks.

NOTE

The left and right fuel rods should move smoothly, uniformly and should not bind or bend when throttle control arm is moved from the idle to the full fuel position. The injector rack should rotate downward with gentle pressure and return to original position when pressure is released.

28. Check the drag on both pins (7 and 16) and adjust the number one right until drag is equal to the number one left

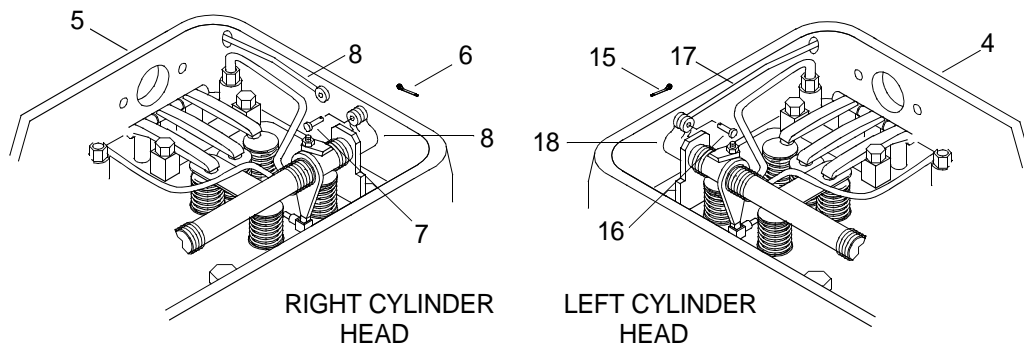

29. On the left cylinder bank (4), remove the cotter pin (15) and clevis pin (16) from the fuel rod (17) and injector rack clevis lever (18).
30. Disconnect the fuel rod (17) from the injector rack clevis lever (18).
31. On the right cylinder bank (5), remove the cotter pin (6) and clevis pin (7) from the fuel rod (8) and injector rack clevis lever (9).

NOTE

Steps 33 through 36 are typical for adjusting the second, third and fourth injector racks of both left and right cylinder banks.

32. Disconnect the fuel rod (8) from the injector rack clevis lever (9).
33. On the left cylinder bank (4) hold the injector rack clevis lever (18) out in the full fuel position and tighten adjusting screw (21) until injector rack (22) starts to rotate slightly or an increase in resistance is felt while tightening.

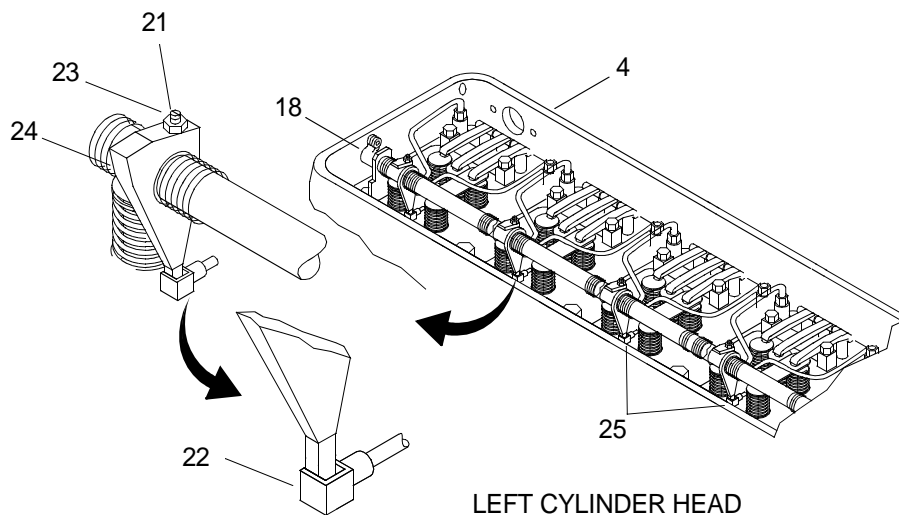

34. Tighten the lock nut (23).
35. Verify the adjustment of the injector rack control lever (24) of the second cylinder, as in steps 10 and 11.

NOTE

Do not alter the adjustment of the first cylinders. All adjustment corrections must be done to the remaining cylinders, using the first cylinders as a guide.

- a. If the adjustment is not correct, make the corrections as outlined, but make the corrections to the second cylinder injector control lever rack (24).
- b. Repeat step 10 to determine if adjustment is too loose and step 11 if the adjustment is too tight.

NOTE

When using a torque wrench to obtain desired torque of the lock nut and maintain the position of the adjusting screw, it will be necessary to use a crowfoot attachment. When using an adaptor, refer to the torque limits work package (WP 0182 00) for adaptor formula to calculate the applied torque.

36. While holding the adjusting screw (3) use a torque wrench and crowfoot adaptor to torque lock nut (2) to 24 - 35 in. lbs (2.7 - 3.9 N-m).
37. Repeat steps 33 through 36 for remaining two injector rack control levers (25).
38. On the left cylinder head (4), install fuel rod (17) on clevis lever (18).
39. Install the clevis pin (16) in the clevis lever (18).
40. Install the cotter pin (15) in the clevis pin (16).
41. On the right cylinder head (5), install fuel rod (8) on the clevis lever (9).
42. Install the clevis pin (7) in the clevis lever (9).
43. Install the cotter pin (6) in the clevis pin (7).
44. Install electronic governor rod assembly. (WP 0097 00)
45. Position the MAIN circuit breaker (1) on propulsion module circuit breaker panel A6 to on.

NOTE

After all injector racks have been adjusted and the fuel rods are installed, verify that all the injector racks return to the original position when the electronic governor is set to the diesel off position.

46. The first engineer verifies the S1 switch (26) of the electronic governor is in the diesel off position.

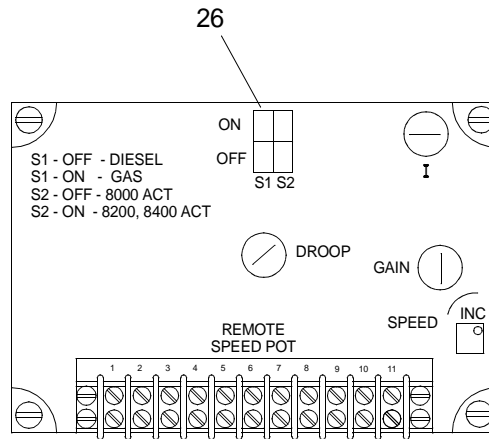

47. The second engineer repeats step 22, (a and b). If the injector racks do not return to the original position, the adjustment procedure must be repeated from step 1.
48. Adjust electronic governor. (WP 0099 00)
49. Install cylinder head poppet valve rockers covers. (WP 0043 00)
50. Install emergency stop solenoid. (WP 0176 00)
51. Install air inlet collector assembly. (WP 0104 00)
52. Install crankcase breather limiter assembly. (WP 0106 00)
53. Install powered section engine hatch. (TM 55-1945-205-24-1-1)
54. Install operators cab. (TM 55-1945-205-24-1-1)
55. Install intake plenum assembly. (TM 55-1945-205-24-1-1)
56. Install main navigation mast. (TM 55-1945-205-24-1-1)
57. Install SINGARS antenna. (TM 11-5820-890-10-8)
58. Perform operational checks. (TM 55-1945-205-10-1)

END OF WORK PACKAGE

**DIRECT SUPPORT MAINTENANCE
CAUSEWAY FERRY
FUEL PUMP
REMOVAL AND INSTALLATION**

INITIAL SETUP:**Tools**

Tool Kit, General Mechanic's (Item 130, WP 0188 00)
Gloves, Chemical (Item 52, WP 0188 00)
Goggles, Industrial (Item 54, WP 0188 00)

Materials/Parts

Gasket
(72582)
NSN 5330-00-212-6290
PN 5150193
Cloth, Cleaning (Item 13, WP 0187 00)

Personnel Required

Engineer 88L

References

TM 55-1945-205-10-1

Equipment Condition

SINGARS Antenna Removed. (TM 11-5820-890-10-8)
Main Navigation Mast Removed. (TM 55-1945-205-24-1-1)
Intake Plenum Assembly Removed. (TM 55-1945-205-24-1-1)
Operators Cab Removed. (TM 55-1945-205-24-1-1)
Engine Cool To Touch.

REMOVE FUEL PUMP

1. Verify MAIN circuit breaker (1) on propulsion module circuit breaker panel A6 is off.

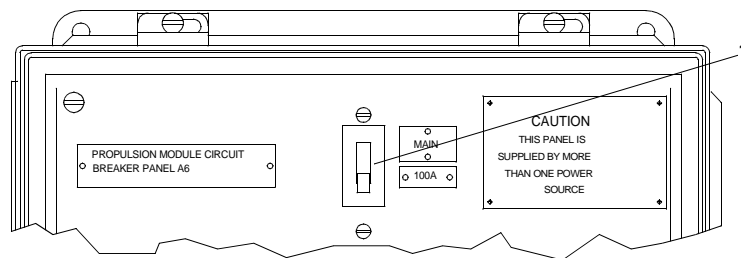

2. Verify fuel supply and return valves (2) are closed.

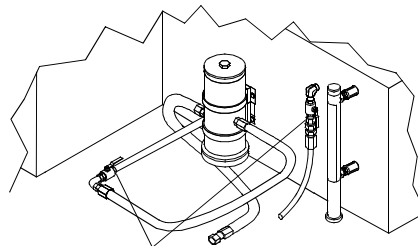

2

3. Place cleaning cloth under fuel lines (3) and (4) to absorb spilled fuel when disconnecting lines.

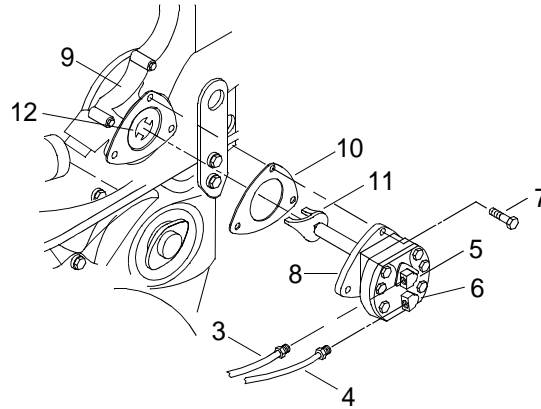

WARNING



CHEMICAL

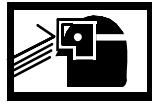

EYE PROTECTION



EXPLOSION



FIRE

4. Disconnect fuel line (3) from elbow (5).

WARNING

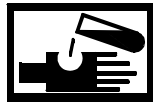

CHEMICAL

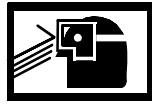

EYE PROTECTION



EXPLOSION



FIRE

5. Disconnect fuel line (4) from elbow (6).

WARNING



CHEMICAL

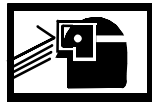

EYE PROTECTION



EXPLOSION



FIRE

6. Remove three nylon patch bolts (7) securing fuel pump (8) to governor housing (9).

WARNING

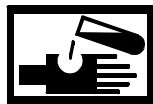

CHEMICAL



EYE PROTECTION



EXPLOSION



FIRE

7. Remove fuel pump (8) from governor housing (9).

WARNING

**CHEMICAL****EYE PROTECTION****EXPLOSION****FIRE**

8. Remove old gasket (10) from governor housing (9). Discard gasket.

INSTALL FUEL PUMP

1. Install new gasket (10) on governor housing (9).

NOTE

The fuel pump must be installed with the inlet opening in the pump cover marked L.H. IN positioned next to the balance weight cover.

2. Install fuel pump (8) on governor housing (9) ensuring that coupling fork (11) lines with the slots in the drive disc (12).
3. Install three nylon patch bolts (7) to secure fuel pump (8) to governor housing (9). Tighten bolts (7).

WARNING

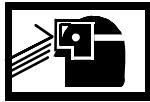
**CHEMICAL****EYE PROTECTION****EXPLOSION****FIRE**

4. Connect the inlet fuel line (4) to inlet port elbow (6) on fuel pump (8). Tighten fuel line (4).

WARNING

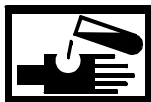
**CHEMICAL****EYE PROTECTION****EXPLOSION****FIRE**

5. Connect outlet port fuel line (3) to outlet port elbow (5) on fuel pump (8). Tighten fuel line (3).

CAUTION

The fuel pump must be primed after installation. Failure to comply could result in the fuel pump seizing after initial start.

6. Prime fuel pump. (WP 0077 00)

WARNING

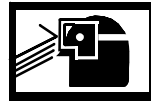
**CHEMICAL****EYE PROTECTION**

7. Dispose of fuel soaked cleaning cloth in accordance with local procedure.
8. Install the engine hatch. (TM 55-1945-205-24-1-1)
9. Install the operators cab. (TM 55-1945-205-24-1-1)
10. Install the intake plenum assembly. (TM 55-1945-205-24-1-1)
11. Install the main navigation mast. (TM 55-1945-205-24-1-1)
12. Install the SINCGARS antenna. (TM 11-5820-890-10-8)
13. Perform operational check of diesel engine. (TM 55-1945-205-10-1)

END OF WORK PACKAGE

**DIRECT SUPPORT MAINTENANCE
CAUSEWAY FERRY
FUEL PUMP
REPAIR**

INITIAL SETUP:**Tools**

Tool Kit, General Mechanic's (Item 130, WP 0188 00)
Tool Kit, Fuel Pump (Item 129, WP 0188 00)
Wrench, Torque (150-750 in. lbs) (Item 142, WP 0188 00)
Wrench Set, Socket (3/8 in. sqdr.) (Item 135, WP 0188 00)
Vise, Machinists, Item 133, WP 0188 00)
Gloves, Chemical (Item 52, WP 0188 00)
Goggles, Industrial (Item 54, WP 0188 00)
Respirator, Air Filtering (Item 109, WP 0188 00)
Hammer, Hand (plastic) (Item 61, WP 0188 00)

Materials/Parts

Gasket
(24617)
NSN 5330-00-599-5577
PN 5161003
Seal, Plain Encased
(72582)
NSN 5330-01-083-3060
PN 5107223
Qty 2
Cloth, Abrasive (Item 12, WP 0187 00)
Oil, Lubricating, Engine, 10W (Item 25, WP 0187 00)
Adhesive (Item 2, WP 0187 00)
Cleaning Compound (Item 10, WP 0187 00)
Lumber, Softwood, Dimension (2 in. X 4 in. X 6 ft Min Wooden Blocks) (Item 23, WP 0187 00)
Qty 2

Personnel Required

Engineer 88L

DISASSEMBLE FUEL PUMP

1. Remove drive coupling fork (1) from pump (2).

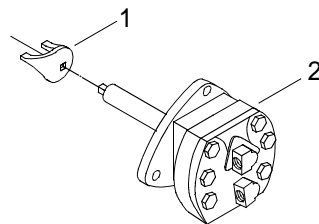

2. Install fuel pump (2) on holding fixture from fuel pump tool set.

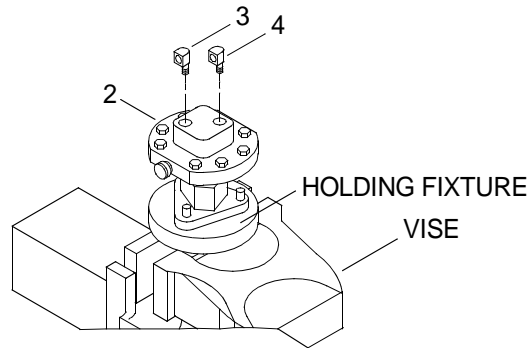

3. Secure holding fixture in a bench vise.
4. Remove inlet port elbow (3) and outlet port elbow (4) from fuel pump (2).
5. Remove eight cap screws (5) and lock washers (6) from fuel pump cover (7).

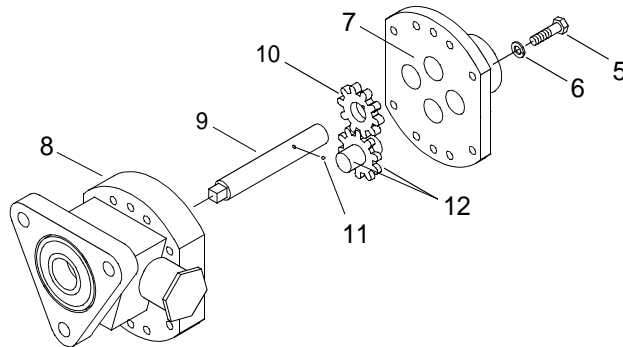

6. Remove the fuel pump cover (7) from the fuel pump body (8).

NOTE

Do not remove the driven gear from the driven shaft. The driven shaft and driven gear are serviced as an assembly.

7. Remove drive shaft (9), drive gear (10) and the gear retaining ball (11) as an assembly from the fuel pump body (8).
8. Remove gear (12) from fuel pump body (8).

9. Disassemble drive shaft (9), drive gear (10) and the gear retaining ball (11) assembly.

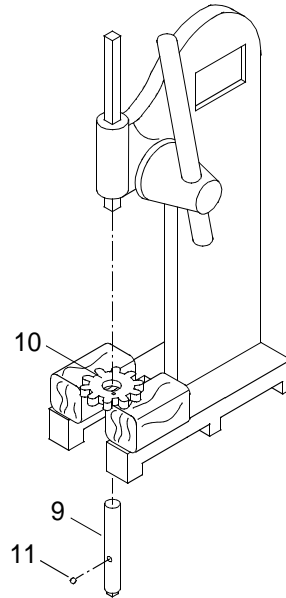

CAUTION

Do not press the squared end of the shaft through the gear. Failure to follow instructions could cause scoring of the oil seal contact surface resulting in premature seal replacement.

- a. Press the drive shaft (9) inward just far enough to remove the gear retaining ball (11).
 - b. Remove the gear retaining ball (11).
 - c. Invert the drive shaft and gear assembly and press the drive shaft (9) from the drive gear (10).
10. Remove the relief valve plug (13) and the copper gasket (14) from the fuel pump body (8). Discard gasket.

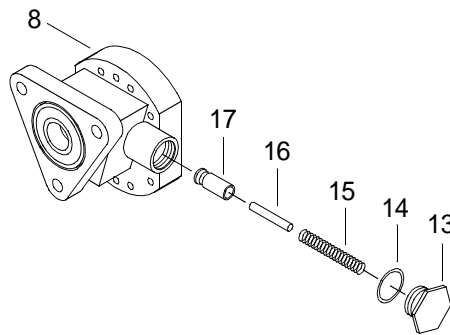

11. Remove the valve spring (15), pin (16) and the relief valve (17) from in the fuel pump body (8).
12. Remove the fuel pump body (8) from holding fixture.
13. Remove the holding fixture from the bench vise.

14. Secure the fuel pump body (8) in the bench vise at a side angle.

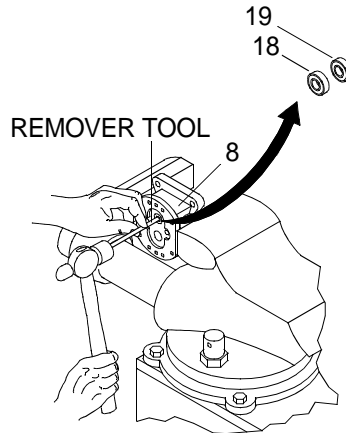

15. Remove the inner and outer oil seal (18, 19) from the fuel pump body (8) using oil seal remover tool.

WARNING

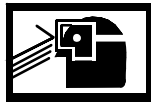

EYE PROTECTION

NOTE

Observe the position of the oil seal lips before the oil seals are removed to permit the installation of new seals in the same position.

- a. Tap the end of the oil seal remover tool with a hammer to remove the seal (18).

WARNING



EYE PROTECTION

- b. Tap the end of the oil seal remover tool with a hammer to remove the seal (19).
- c. Discard oil seals (18,19).

16. Remove the fuel pump body (8) from the bench vise.

CLEAN FUEL PUMP

WARNING

**CHEMICAL****EYE PROTECTION**

1. Using cleaning compound, clean all fuel pump parts.

WARNING

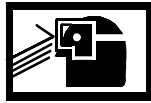
**EYE PROTECTION**

Do not exceed 40 PSI (279.79 kPa) compressed air pressure. Failure to comply could result in serious injury to personnel.

2. Using compressed air, dry parts.

INSPECT FUEL PUMP

1. Inspect the gear retaining ball slot in the drive gear for wear. Replace defective parts.

NOTE

Replace the driven gear and driven shaft only as an assembly.

2. Inspect the pump gear teeth for scoring, chipping or wear. Replace defective parts.
3. Inspect the driven shaft for wear or scoring. Replace defective parts.
4. Inspect the relief valve for scoring or burrs. If found, repair with a fine emery cloth or crocus cloth.
5. If scoring and burrs are present after re-work. Replace defective part.
6. Inspect the relief valve for proper seating into the valve cavity of the pump body. Replace defective parts.
7. Inspect the relief valve spring for wear or distortion replace defective parts.
8. Inspect the fuel pump body for scoring, wear, nicks or chipping. Replace defective parts.
9. Inspect the fuel pump cover for scoring, wear, nicks or chipping. Replace defective parts.
10. Inspect the relief valve plug for wear, scoring, chipping, stripped threads or cracks. Replace defective parts.
11. Inspect the relief valve pin for wear or distortion. Replace defective parts.

ASSEMBLE FUEL PUMP

1. Place the fuel pump body (8) on wooden wedges.

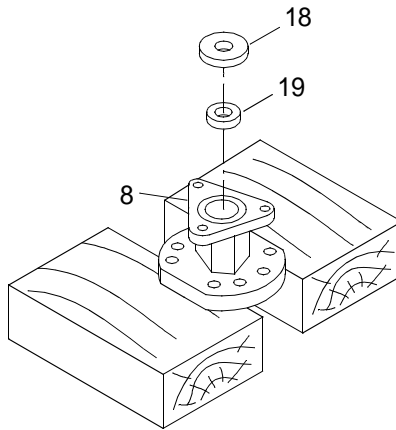

2. Install new oil seals (18, 19) in fuel pump body (8).

WARNING

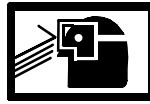
**CHEMICAL****EYE PROTECTION**

- a. Lubricate the lips of the oil seals (18,19) with a light coat of lubricating oil.
- b. Align the new inner oil seal (19) on the pilot of the installer handle so that the lip of the oil seal will face up.

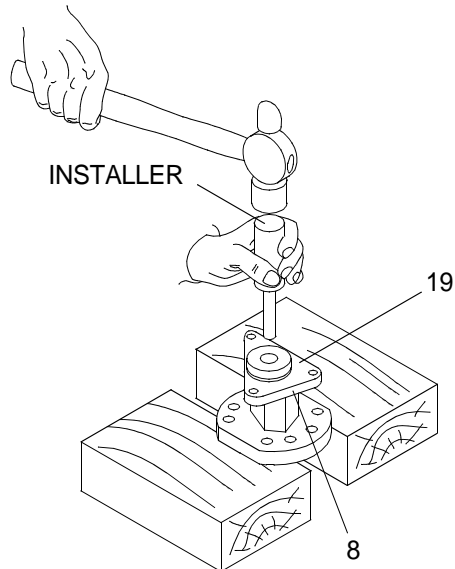

- c. Insert the pilot of the installer handle in the fuel pump body (8) aligning oil seal (19) with the fuel pump body flange so that the oil seal starts straight.
- d. Use hammer to drive oil seal (19) into the fuel pump body (8) until it bottoms out.

- e. Place the shorter end of the adaptor over the pilot and against the shoulder of the installer handle.

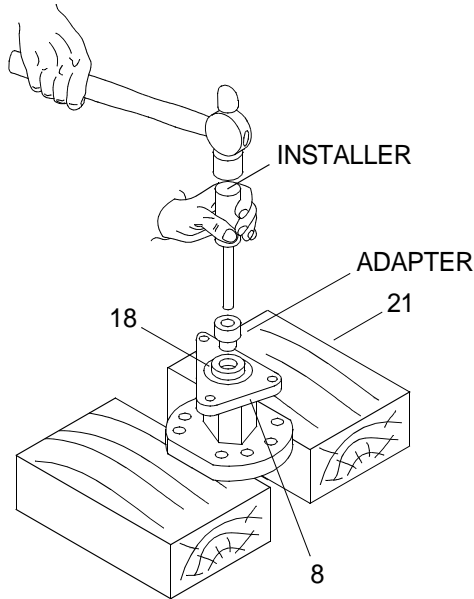

- f. Align the new outer oil seal (18) on the pilot of the installer handle so that the lip of the oil seal (18) faces the adaptor.
- g. Insert the pilot of the installer handle in the fuel pump body (8) aligning oil seal (18) with the fuel pump body flange so that the oil seal starts straight.

NOTE

The oil seals will be positioned so that space between them will correspond with the drain holes located in the bottom of the fuel pump body.

- h. Use hammer to drive oil seal (18) into the fuel pump body (8) until it is flush with the gasket surface.
3. Install the relief valve (17), valve spring (15), pin (16), new copper gasket (14) and the relief valve plug (13) into the valve cavity of the fuel pump body (8).

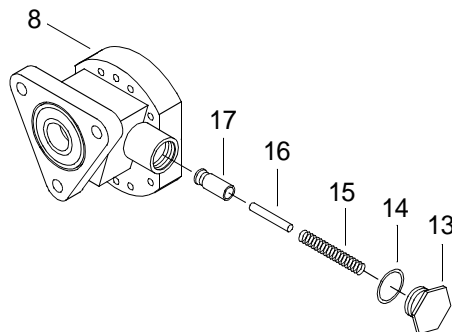

- a. Secure the fuel pump body (8) in a bench vise, equipped with soft jaws, with the relief valve cavity facing up.

WARNING

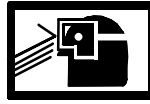
**CHEMICAL****EYE PROTECTION**

- b. Lubricate the outside diameter of the relief valve (17), with a light coat of lubricating oil.

WARNING

**CHEMICAL****EYE PROTECTION**

- c. Install the relief valve (17) into the valve cavity of the fuel pump body (8) with the hollow end up.
- d. Insert the valve spring (15) inside of the relief valve (17).
- e. Insert the pin (16) in the valve spring (15).
- f. Install a new copper gasket (14) on the relief valve plug (13).
- g. Install the relief valve plug (13) in the fuel pump body (8).
- h. Using torque wrench and socket set, torque plug (13) to 216 - 240 in. lb (24-27 N-m).
4. Assemble drive shaft (9), drive gear (10) and retaining ball (11).

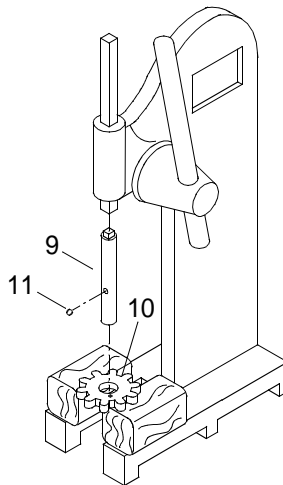

- a. Position drive gear (10) on a press.

CAUTION

Do not press the squared end of the shaft through the gear. Failure to comply could result in premature seal failure.

- b. Press the drive gear (10) inward on the drive shaft (9) just far enough to expose the gear retaining ball (11) detent.
- c. Place the gear retaining ball (11) in the detent.
- d. Press the drive gear (10) back until the end of the slot contacts the gear retaining ball (11).

WARNING

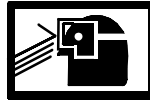
**CHEMICAL****EYE PROTECTION**

5. Lubricate the drive shaft (9) and drive gear (10) with lubricating oil.

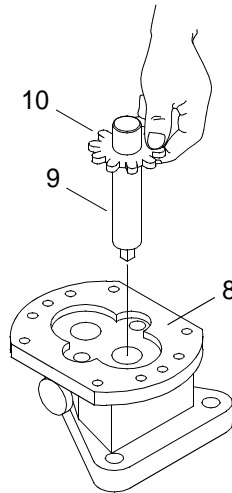

WARNING

**CHEMICAL****EYE PROTECTION**

6. Insert the square end of the drive shaft (9) into the opening of the gear side of the fuel pump body (8) and through the oil seals (18, 19).

7. Install the gear assembly (12) in the fuel pump body (8).

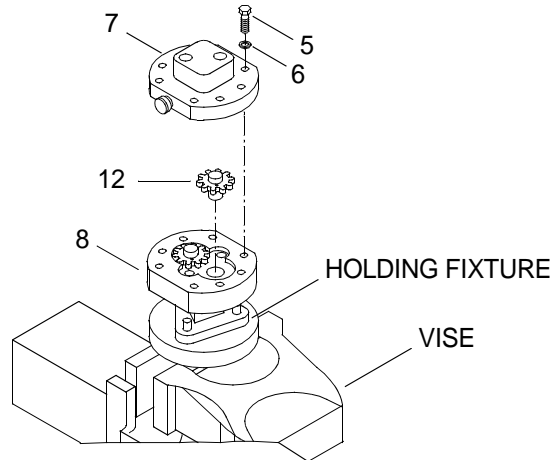

WARNING



CHEMICAL



EYE PROTECTION

CAUTION

The driven gear must be centered on the driven shaft to give proper end clearance and the chamfered end of the gear teeth of the production gear, must face the fuel pump body. Failure to comply may result in damage to equipment.

NOTE

If a service replacement gear with a slot is used, the slot must face toward the fuel pump cover.

- a. Using lubricating oil, lubricate the drive shaft (9) and gear assembly (12).

WARNING



CHEMICAL



EYE PROTECTION

- b. Install the drive shaft (9) and gear (10) in pump body (8).
8. Install the fuel pump cover (7) on the fuel pump body (8).

WARNING

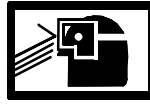
**CHEMICAL****EYE PROTECTION**

- a. Apply a thin coat of adhesive sealant on the face of the fuel pump cover (5) outside of the gear pocket area.
- b. Align the fuel pump cover (7) with two dowel pins on the fuel pump body (8).
- c. Install the fuel pump cover (7) on the fuel pump body (8).
- d. Install eight bolts (5) and lock washers (6) to secure fuel pump cover (7) to the fuel pump body (8). Tighten bolts alternately and evenly.

WARNING

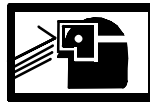
**CHEMICAL****EYE PROTECTION**

CAUTION

Do not coat the first two threads of fittings with sealing compound. Failure to comply may cause damage to equipment.

9. Avoiding the first two threads, apply a thin coat of non-hardening sealant to threads of inlet port (3) and outlet port (4) elbows.
10. Install the inlet port (3) and outlet port (4) elbows onto the replacement fuel pump (6).

NOTE

To allow for proper alignment of fittings begin at low end of torque and increase torque until alignment is achieved.

11. Using torque wrench and socket set, torque ¼ in. elbow fittings to 168 - 192 in. lbs (19-22 N-m).
12. Using torque wrench and socket set, torque 3/8 in. elbow fittings to 216 - 264 in. lb (24-30 N-m).
13. Using torque wrench and socket set, torque ½ in. elbow fittings to 240 - 300 in. lb (27-34 N-m).

14. Remove the fuel pump (2) from the bench vise.

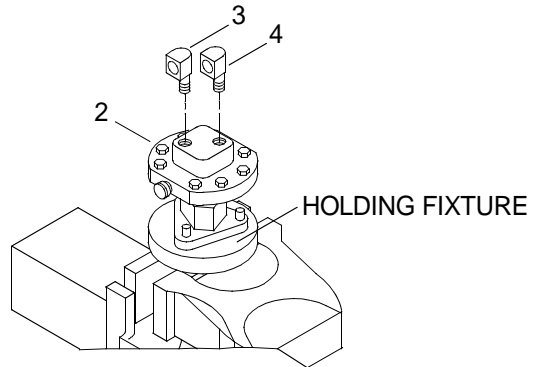

15. Remove the fuel pump (2) from holding fixture.

16. Install drive coupling fork (1) on the end of the pump drive shaft (9).

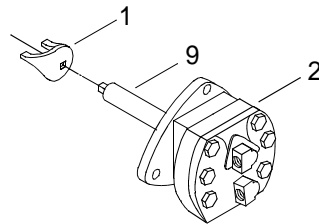

END OF WORK PACKAGE

**UNIT LEVEL MAINTENANCE
CAUSEWAY FERRY
FUEL PRIMING PUMP
REPLACEMENT**

INITIAL SETUP:**Tools**

Tool Kit, General Mechanic's (Rail and Marine) (Item 131, WP 0188 00)
 Gloves, Chemical (Item 52, WP 0188 00)
 Goggles, Industrial (Item 54, WP 0188 00)
 Pan, Drain (Item 87, WP 0188 00)

Materials/Parts

Pump, Engine Priming
 (72582)
 NSN 2910-00-997-2394
 PN 5110760
 Spill Clean-Up Kit, Hazardous Material (Item 32, WP 0187 00)
 Tape, Antiseizing (Item 34, WP 0187 00)

Personnel Required

Engineer 88L

References

TM 55-1945-205-10-1

Equipment Condition

Engine Cool To Touch.

REMOVE FUEL PRIMING PUMP

1. Verify MAIN circuit breaker (1) on propulsion module circuit breaker panel A6 is off.

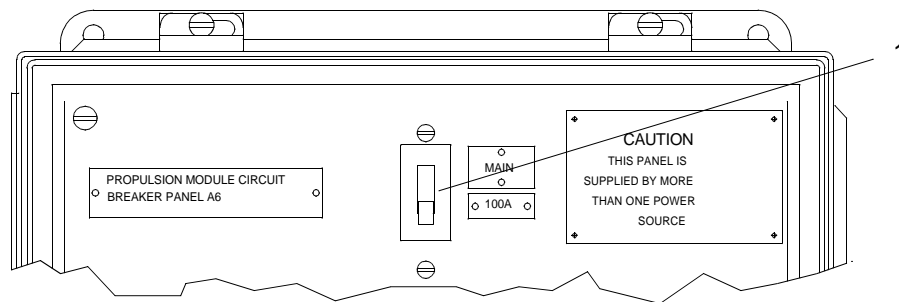

- Verify fuel supply and return valves (2) are closed.

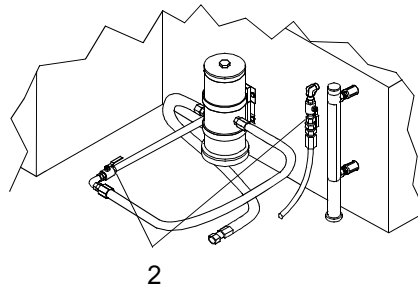

2. Place a drain pan under fuel lines (3) and (4).

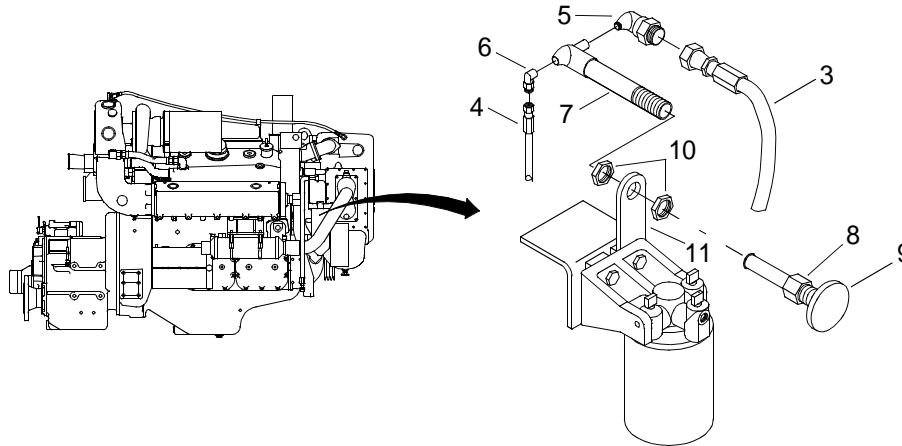

WARNING



CHEMICAL



EYE PROTECTION

NOTE

This task is typical for port and starboard engines.

3. Remove fuel lines (3) and (4) from fittings (5) and (6) and drain fuel into drain pan.
4. Remove fittings (5) and (6) from primer pump body (7).
5. Loosen retaining nut (8) on primer pump body (7).
6. Remove primer pump (9) from primer pump body (7).
7. Loosen nuts (10) on primer pump body (7).
8. Remove outside nut (10) from primer pump body (7).
9. Remove primer pump body (7) from bracket (11).
10. Remove inside nut (10) from primer pump body (7). Discard primer pump body (7).

WARNING

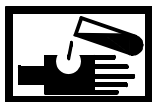

CHEMICAL



EYE PROTECTION

11. Remove drain pan and dispose of contents in accordance with local procedures.

INSTALL FUEL PRIMING PUMP

1. Install inside nut (10) on new primer pump body (7).
2. Position new primer pump body (7) through bracket (11).
3. Install outside nut (10) on primer pump body (7).
4. Tighten nuts (10).
5. Install new primer pump (9) in primer pump body (7).
6. Tighten nut (8) on primer pump body (7).

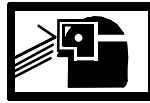
WARNING**CHEMICAL****EYE PROTECTION**

7. Wrap fittings (5) and (6) threads with antiseize tape.
8. Install fittings (5) and (6) on primer pump body (7).

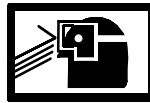
WARNING**CHEMICAL****EYE PROTECTION**

9. Connect fuel lines (3) and (4) to fittings (5) and (6).
10. Tighten fuel lines (3) and (4).
11. Prime fuel system. (WP 0077 00)
12. Start engine. (TM 55-1945-205-10-1)
13. Check connections on primer pump body (7) for leaks.
14. Shut engine down. (TM 55-1945-205-10-1)

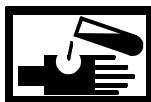
WARNING**CHEMICAL****EYE PROTECTION****SLICK FLOOR**

15. Clean up spilled fluids with spill kit and dispose of spill kit in accordance with local procedure.

END OF WORK PACKAGE

**DIRECT SUPPORT MAINTENANCE
CAUSEWAY FERRY
ELECTRONIC GOVERNOR ROD ASSEMBLY
REPLACEMENT**

INITIAL SETUP:**Tools**

Tool Kit, General Mechanic's (Item 130, WP 0188 00)

Materials/Parts

Rod Assembly
(72582)
PN 23504485

Personnel Required

Engineer 88L

References

TM 55-1945-205-10-1

REMOVE ELECTRONIC GOVERNOR ROD ASSEMBLY

1. Verify MAIN circuit breaker (1) on propulsion module circuit breaker panel A6 is off.

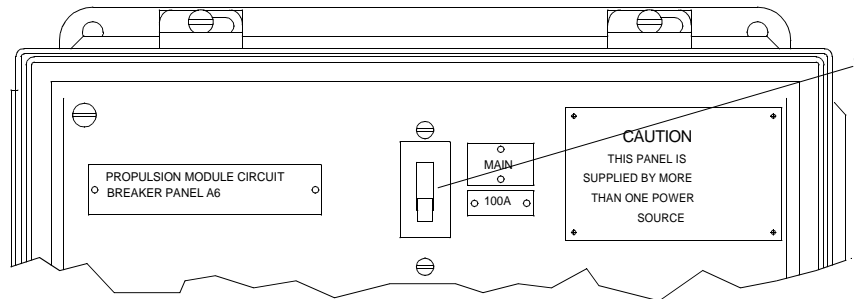

2. Remove two hex nuts (2) and cap screws (3) with lock washers (4) from rod assembly (5).

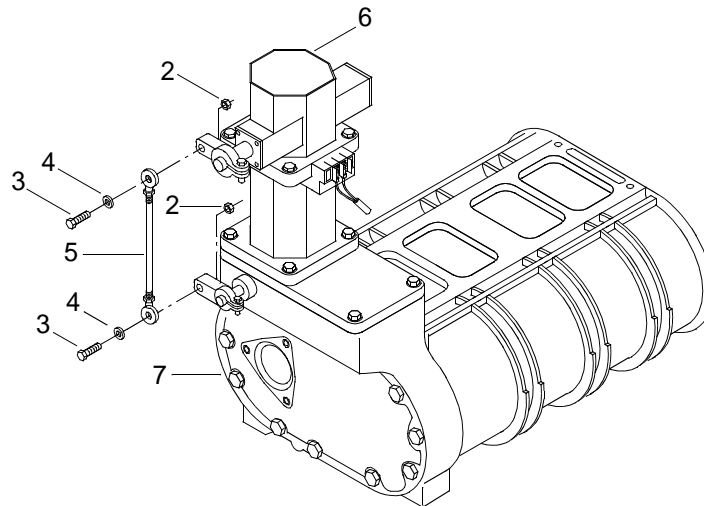

3. Remove rod assembly (5) from actuator (6) and blower (7). Discard rod assembly.

INSTALL ELECTRONIC GOVERNOR ROD ASSEMBLY

1. Install new rod assembly (5) on actuator (6) and blower (7).
2. Install two cap screws (3) with lock washers (4) and hex nuts (2) on rod assembly (5).
3. Tighten hex nuts (2).
4. Perform operational check of diesel engine. (TM 55-1945-205-10-1)

END OF WORK PACKAGE

**DIRECT SUPPORT MAINTENANCE
CAUSEWAY FERRY
ELECTRONIC GOVERNOR ACTUATOR
REPLACEMENT**

INITIAL SETUP:**Tools**

Tool Kit, General Mechanic's (Item 130, WP 0188 00)

Materials/Parts

Actuator, Governor
(72582)
NSN 5330-00-758-2872
PN 23502463
Gasket
(72582)
PN 8927412

Personnel Required

Engineer 88L

References

TM 55-1945-205-10-1

Equipment Condition

Engine Cool To Touch.

REMOVE ELECTRONIC GOVERNOR ACTUATOR**NOTE**

The following task is typical for the removal and installation of electronic governor actuators.

1. Verify MAIN circuit breaker (1) on propulsion module circuit breaker panel A6 is off.

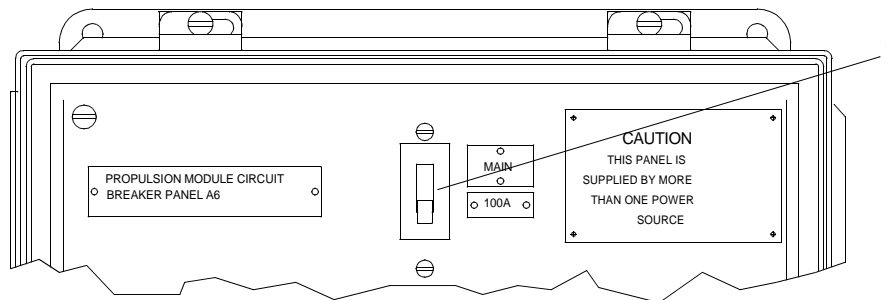

2. Tag and disconnect two wires (2) from the back of the electronic governor actuator (3).

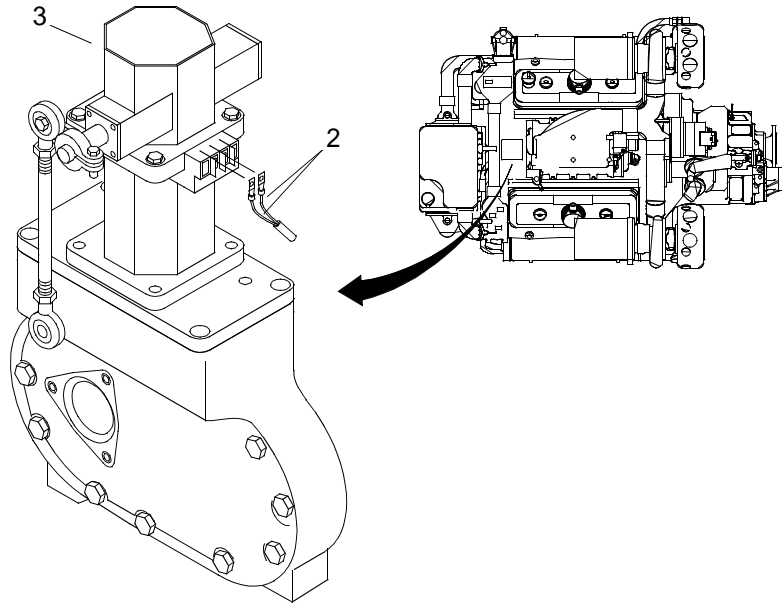

3. Remove hex head bolt (4), flat washer (5), lock washer (6) and hex nut (7) from linkage (8) and disconnect linkage (8) from governor actuator (3).

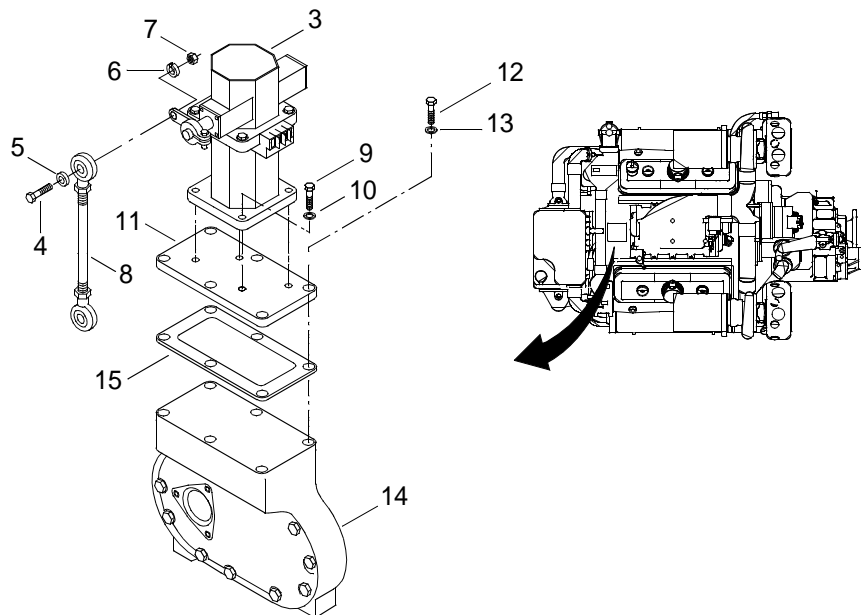

4. Remove four key socket head screws (9) and lock washers (10) from governor actuator (3).
5. Remove governor actuator (3) from adaptor plate (11). Discard governor actuator (3).
6. Remove six bolts (12) and lock washers (13) securing adaptor plate (11) to blower housing end plate (14).
7. Remove adaptor plate (11) and gasket (15). Discard gasket (15).

INSTALL ELECTRONIC GOVERNOR ACTUATOR

1. Position new gasket (15) and adaptor plate (11) on blower housing end plate (14).
2. Install six bolts (12) and lock washers (13) to secure adaptor plate (11) to blower housing end plate (14).
3. Tighten bolts (12).
4. Position new governor actuator (3) on adaptor plate (11).
5. Install four key socket head screws (9) and lock washers (10) to secure governor actuator (3) to adaptor plate (11).
6. Tighten key socket head screws (9).
7. Connect linkage (8) to governor actuator (3) and install hex head bolt (4), flat washer (5), lock washer (6) and hex nut (7).
8. Tighten nut (7).
9. Connect two wires (2) as tagged, on the back of the electronic governor actuator (3) and remove tags.
10. Adjust engine electronic governor controller. (WP 0099 00)
11. Perform operational check of diesel engine. (TM 55-1945-205-10-1)

END OF WORK PACKAGE

**GENERAL SUPPORT MAINTENANCE
CAUSEWAY FERRY
ELECTRONIC GOVERNOR CONTROLLER
REPLACEMENT AND ADJUSTMENT**

INITIAL SETUP:**Tools**

Tool Kit, General Mechanic's (Item 130, WP 0188 00)
Gloves, Chemical (Item 52, WP 0188 00)
Goggles, Industrial (Item 54, WP 0188 00)

Materials/Parts

Controller, Governor
(72582)
PN 23502466
Strap, Tiedown (Item 33, WP 0187 00)
Antiseize Compound (Item 6, WP 0187 00)

Personnel Required

Engineer 88L

References

TM 55-1945-205-10-1

REMOVE ELECTRONIC GOVERNOR CONTROLLER

1. Verify MAIN circuit breaker (1) on propulsion module circuit breaker panel A6 is off.

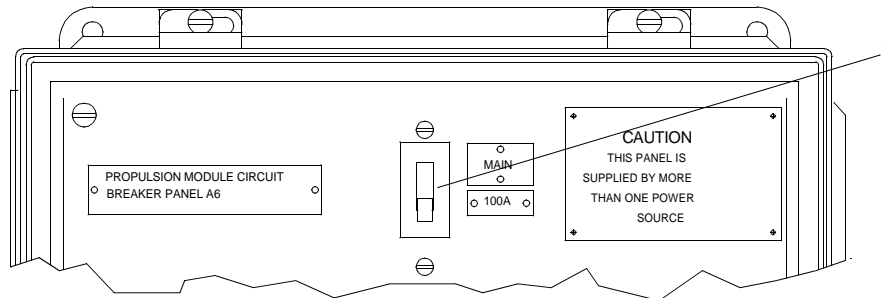

2. Loosen six screws (2) and rotate six clamps (3) securing cover (4) to enclosure (5).

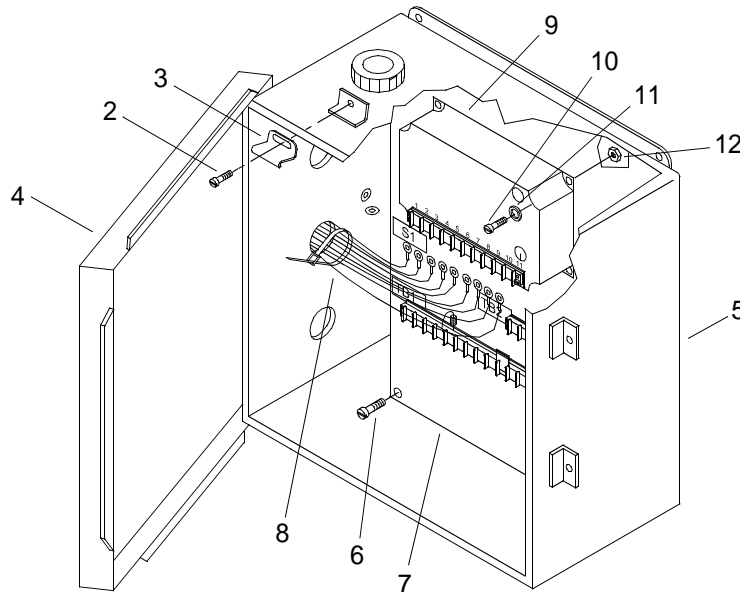

3. Open cover (4).
4. Remove four screws (6) from panel (7).
5. Remove panel (7) from enclosure (5).
6. Cut tiedown straps securing electrical wires (8).
7. Disconnect and tag all electrical wires (8) from governor controller (9).

NOTE

In order to gain access to the nuts securing the governor controller, it will be necessary to pull downward on the top of the panel.

8. Remove four pan head screws (10), four lock washers (11) and four insert nuts (12) securing governor controller (9) to panel (7).
9. Remove governor controller (9).

INSTALL ELECTRONIC GOVERNOR CONTROLLER

WARNING



CHEMICAL



EYE PROTECTION

1. Apply antiseize compound to threads of screws (2, 6 and 10).
2. Install new governor controller (9).

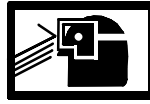
WARNING**CHEMICAL****EYE PROTECTION**

3. Secure governor controller (9) with four pan head screws (10) and four washers (11) and four insert nuts (12).
4. Install panel (7) in enclosure (5).

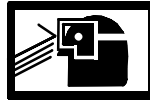
WARNING**CHEMICAL****EYE PROTECTION**

5. Secure panel (7) with four screws (6).
6. Connect electrical wiring (8) as tagged to governor controller (9).
7. Secure loose secure electrical wiring (8) with tiedown straps.

ADJUST ELECTRONIC GOVERNOR CONTROLLER

1. Set governor (9) switches (13 and 14) and potentiometers (15, 16, 17 and 18).

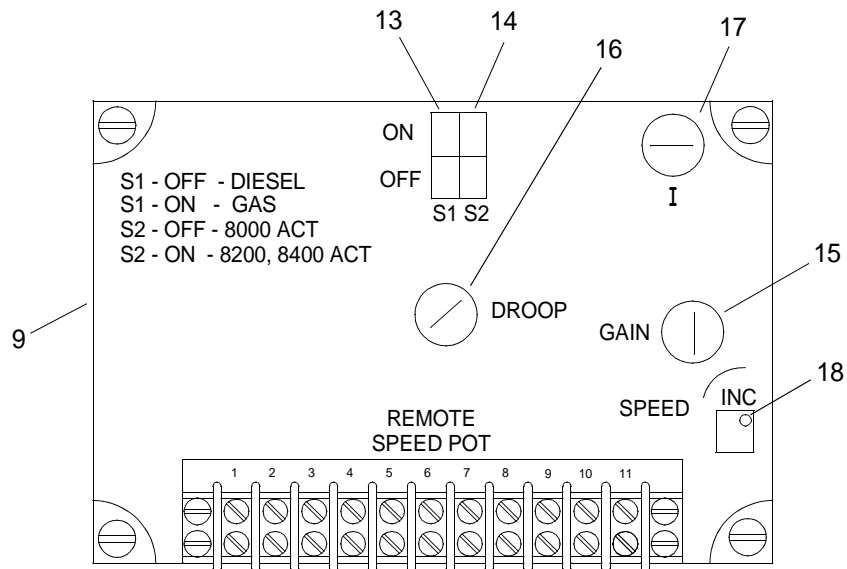

- a. Position switch S1 (13) to the OFF position.
- b. Position switch S2 (14) to the ON position.
- c. Set GAIN potentiometers (15) to the second division from the zero position.

NOTE

The throttle potentiometers and the governor actuator operate synchronously. Therefore, there is no delay so the DROOP adjustment screw must remain in the full counterclockwise position.

- d. Set DROOP potentiometers (16) to the full counterclockwise position.
 - e. Set S1 potentiometers (17) to the third division from the zero position.
2. Start the engine. (TM 55-1945-205-10-1)

NOTE

If the engine does not idle at 800 RPM, the speed potentiometers (18) must be adjusted.

3. Operate the engine at 800 RPM.
4. Adjust the speed potentiometers (18) until the engine maintains 800 RPM.

NOTE

The engine should not be under load while adjusting the I and GAIN.

5. Finalize the S1 and GAIN settings.

NOTE

The actuator lever may need to be disturbed to make it oscillate.

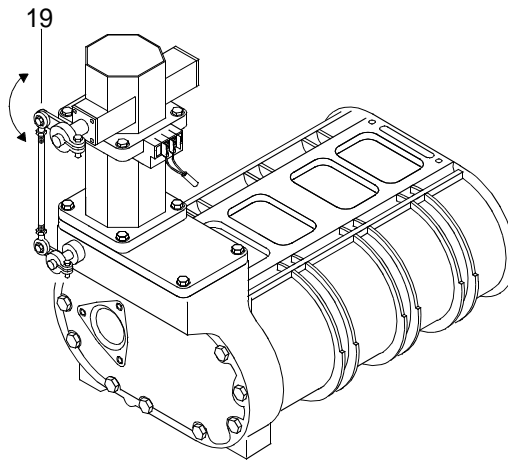

- a. Turn the GAIN potentiometers (15) clockwise slowly until actuator lever (19) oscillates.
- b. Turn the GAIN potentiometers (15) counterclockwise slowly until the actuator lever (19) stops oscillating.

NOTE

The gain adjustment is set correctly when the actuator lever is disturbed and it oscillates three to five times getting slower on each oscillation until it stabilizes.

- c. Disturb the actuator lever (19) and verify that it oscillates three to five times getting slower and slower.
- d. Operate the vessel and verify that the load-to-performance change is satisfactory.

NOTE

If the vessel's performance is satisfactory, skip to step (7).

- e. Turn the GAIN potentiometers counterclockwise one setting.

NOTE

It may be necessary to upset the actuator lever to cause oscillation.

- f. Turn the S1 setting clockwise slowly until the actuator lever (19) becomes unstable and oscillates slowly.
- g. Turn the S1 potentiometers slowly counterclockwise until the actuator lever (19) is stable.
- h. Disturb the actuator lever (19) and verify that it oscillates three to five times, getting slower and slower.
- i. Operate the vessel and verify that the load-to-performance change is satisfactory.
6. Shut engine down. (TM 55-1945-205-10-1)

WARNING

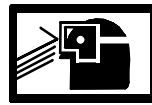
**CHEMICAL****EYE PROTECTION**

7. Close cover (4), rotate six clamps (3) and secure with six screws (2).

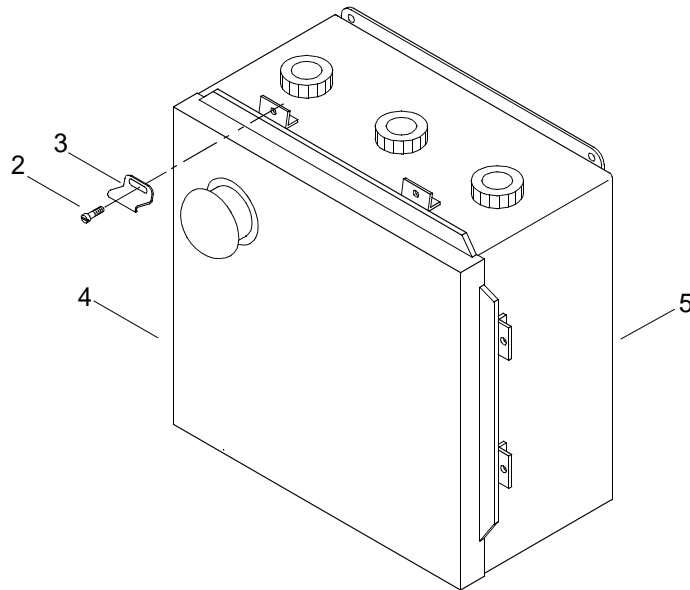
**END OF WORK PACKAGE**

**DIRECT SUPPORT MAINTENANCE
CAUSEWAY FERRY
ELECTRONIC GOVERNOR MAGNETIC PICK-UP
REPLACEMENT**

INITIAL SETUP:**Tools**

Tool Kit, General Mechanic's (Item 130, WP 0188 00)

Materials/Parts

Pick-up, Magnetic
(72582)
PN 8923172

Personnel Required

Engineer 88L

References

TM 55-1945-205-10-1

Equipment Condition

SINGARS Antenna Removed. (TM 11-5820-890-10-8)
Mast Assembly Removed. (TM 55-1945-205-24-1-1)
Operators Cab Or Air Intake Plenum Removed. (TM 55-1945-205-24-1-1)
Powered Section Engine Hatch Removed. (TM 55-1945-205-24-1-1)
Exhaust System Removed. (TM 55-1945-205-24-1-1)
Marine Gear To Transfer Case Machinery Guard Removed. (TM 55-1945-205-24-1-1)
Transfer Case To Pump-Jet Machinery Guard Removed. (TM 55-1945-205-24-1-1)
Marine Gear To Transfer Case Drive Shaft Removed. (TM 55-1945-205-24-1-1)
Marine Gear Drained. (TM 55-1945-205-24-1-3)
Electronic Control Valve Removed. (TM 55-1945-205-24-1-3)
Pressure Vented From Hydraulic System. (TM 55-1945-205-24-1-1)
Hydraulic Pump Removed. (TM 55-1945-205-24-1-1)
Marine Gear Oil Pump Removed. (TM 55-1945-205-24-1-3)
Marine Gear Removed. (TM 55-1945-205-24-1-3)

REMOVE ELECTRONIC GOVERNOR MAGNETIC PICK-UP

1. Disconnect electrical connector (1) from magnetic pick-up (2).

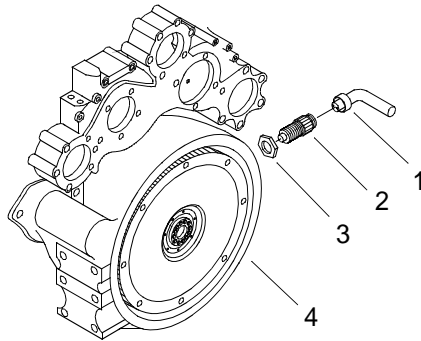

2. Loosen jam nut (3) on magnetic pick-up (2).
3. Remove magnetic pick-up (2) from flywheel housing (4).

-
- Remove jam nut (3) from magnetic pick-up (2). Discard magnetic pick-up (2).

INSTALL ELECTRONIC GOVERNOR MAGNETIC PICK-UP

- Install jam nut (3) on new magnetic pick-up (2).
- Install magnetic pick-up (2) into flywheel housing (4).

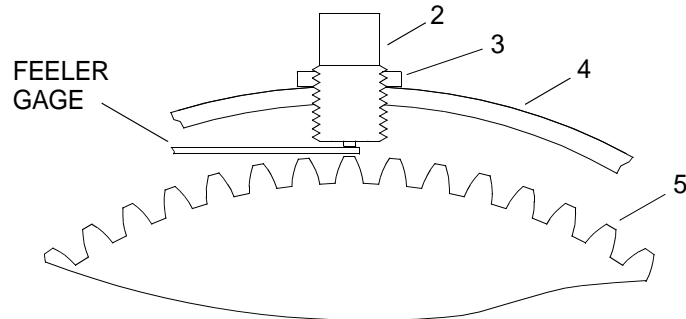

- Using feeler gage, verify magnetic pick-up (2) is 0.015 ± 0.005 in. (0.0381 ± 0.0127 cm.) from flywheel ring gear (5).
- Tighten jam nut (3) on magnetic pick-up (2).
- Verify gap between magnetic pick-up (2) and ring gear (5).
- Connect electrical connector (1) to magnetic pick-up (2).
- Install marine gear. (TM 55-1945-205-24-1-3)
- Install marine gear oil pump. (TM 55-1945-205-24-1-3)
- Install hydraulic pump. (TM 55-1945-205-24-1-1)
- Service hydraulic system. (TM 55-1945-205-24-1-1)
- Install electronic control valve. (TM 55-1945-205-24-1-3)
- Service marine gear. (TM 55-1945-205-24-1-3)
- Install marine gear to transfer case drive shaft. (TM 55-1945-205-24-1-1)
- Install transfer case to pump-jet machinery guard. (TM 55-1945-205-24-1-1)
- Install marine gear to transfer case machinery guard. (TM 55-1945-205-24-1-1)
- Install exhaust system. (TM 55-1945-205-24-1-1)
- Install powered section engine hatch. (TM 55-1945-205-24-1-1)
- Install operators cab or air intake plenum. (TM 55-1945-205-24-1-1)
- Install mast assembly. (TM 55-1945-205-24-1-1)
- Install SINCGARS antenna. (TM 11-5820-890-10-8)
- Perform operational checks. (TM 55-1945-205-10-1)

END OF WORK PACKAGE

**DIRECT SUPPORT MAINTENANCE
CAUSEWAY FERRY
ELECTRONIC GOVERNOR DRIVE ASSEMBLY
REMOVAL AND INSTALLATION**

INITIAL SETUP:**Tools**

Tool Kit, General Mechanic's (Item 130, WP 0188 00)
Hammer, Hand, (Dead Blow) (Item 59, WP 0188 00)

Materials/Parts

Gasket
(72582)
NSN 5330-01-270-1161
PN 8924266
Washer, Flat, Copper
(66242)
NSN 5310-00-271-7426
PN AD 91
Qty 3

Personnel Required

Engineer 88L

References

TM 55-1945-205-10-1

Equipment Condition

Engine Cool To Touch
SINCGARS Antenna Removed. (TM 11-5820-890-10-8)
Main Navigation Mast Removed. (TM 55-1945-205-24-1-1)
Intake Plenum Assembly Removed. (TM 55-1945-205-24-1-1)
Operators Cab Removed. (TM 55-1945-205-24-1-1)
Powered Section Engine Hatch Removed. (TM 55-1945-205-24-1-1)
Crankcase Breather Limiter Assembly Removed. (WP 0106 00)
Air Inlet Collector Assembly Removed. (WP 0104 00)
Cylinder Head Poppet Valve Rocker Arm Covers Removed. (WP 0043 00)
Fresh Water Cooling System Drained. (WP 0134 00)
Fresh Water Cooling System Bypass Hoses Removed. (WP 0148 00)
Fuel Pump Removed. (WP 0094 00)
Tachometer Signal Generator (Sending Unit) Removed (WP 0173 00)
Blower Shaft And Spring Assembly Removed. (WP 0109 00)
Electronic Governor Rod Assembly Removed. (WP 0097 00)
Electronic Governor Actuator Removed. (WP 0098 00)

REMOVE THE GOVERNOR DRIVE ASSEMBLY

1. On the left and right cylinder head, remove the cotter pin (1) and clevis pin (2) from the fuel rod (3) and injector rack clevis (4).

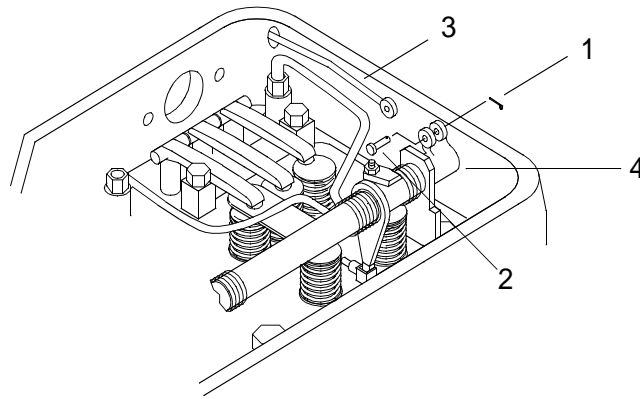

2. Remove clamps (5) from hoses (6).

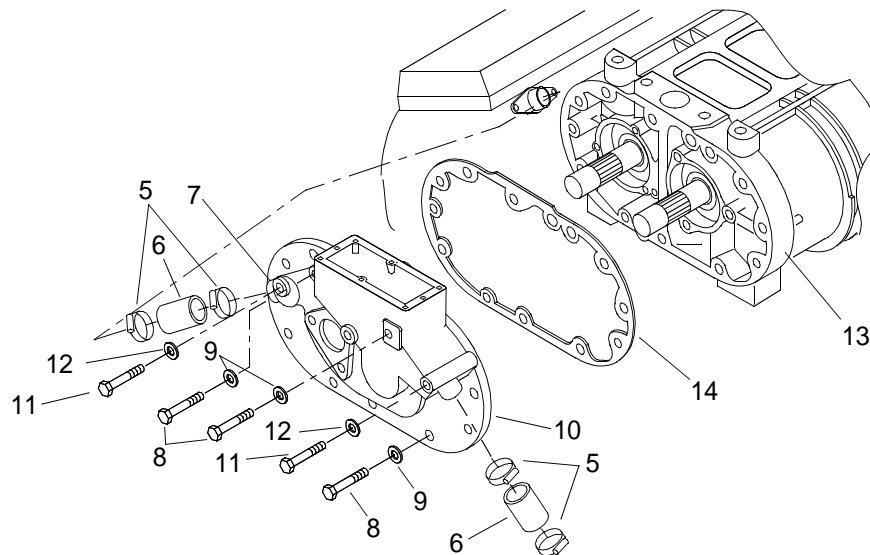

3. Slide hoses (6) up tubes (7).

NOTE

Tag and retain bolts for proper reinstallation.

4. Remove seven cap screws (8) and lock washers (9) from governor drive (10).
5. Remove three cap screws (11) and copper washers (12) from governor drive (10) and discard copper washers.

CAUTION

Do not pry governor drive from blower end plate, the governor drive is doweled into position. Failure to comply will result in damage to the governor drive.

6. Tap governor drive (10) with a dead blow hammer to break seal from blower end plate (13).
7. Remove governor drive (10) from blower end plate (13).
8. Remove and discard gasket (14) from blower end plate (13).

INSTALL THE GOVERNOR DRIVE ASSEMBLY

1. Install new gasket (14) on blower end plate (13).

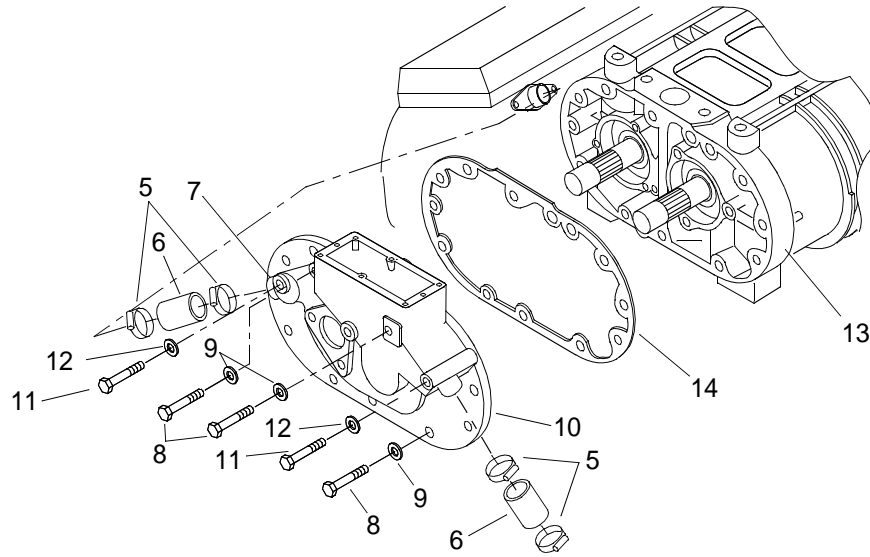

2. Install governor drive (10) on blower end plate (13).
3. Install three cap screws (11) and three new copper washers (12) on governor drive (10).
4. Install seven cap screws (8) and lock washers (9) on governor drive (10).
5. Slide hoses (6) down tubes (7) overlapping both tube (7) and cover (15).
6. Install clamps (5) on hoses (6).
7. On the left and right cylinder heads, install cotter pins (1) and clevis pins (2) from the fuel rods (3) and injector rack clevises (4).

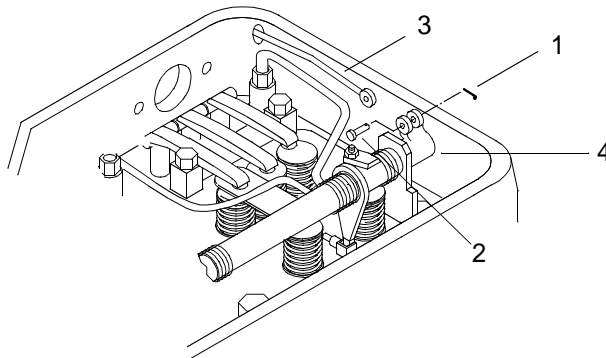

8. Install electronic governor actuator. (WP 0098 00)
9. Install electronic governor rod assembly. (WP 0097 00)
10. Install blower shaft and spring assembly. (WP 0109 00)
11. Install tachometer signal generator (sending unit). (WP 0173 00)

12. Install fuel pump. (WP 0094 00)
13. Install fresh water cooling system bypass hose. (WP 0148 00)
14. Install cylinder head poppet valve rocker arm covers. (WP 0043 00)
15. Install air inlet collector assembly. (WP 0104 00)
16. Install crankcase breather limiter assembly. (WP 0106 00)
17. Service fresh water cooling system. (WP 0133 00)
18. Install powered section engine hatch. (TM 55-1945-205-24-1-1)
19. Install operators cab removed. (TM 55-1945-205-24-1-1)
20. Install intake plenum assembly. (TM 55-1945-205-24-1-1)
21. Install main navigation mast. (TM 55-1945-205-24-1-1)
22. Install SINGARS antenna. (TM 11-5820-890-10-8)
23. Perform operational check of diesel engine. (TM 55-1945-205-10-1)

END OF WORK PACKAGE

**GENERAL SUPPORT MAINTENANCE
CAUSEWAY FERRY
ELECTRONIC GOVERNOR DRIVE ASSEMBLY
REPAIR**

INITIAL SETUP:**Tools**

Tool Kit, General Mechanic's (Item 130, WP 0188 00)
 Press, Arbor, Hand Operated (Item 97, WP 0188 00)
 Pliers, Retaining Ring (Item 93, WP 0188 00)
 Apron, Utility (Item 8, WP 0188 00)
 Gloves, Chemical (Item 52, WP 0188 00)
 Goggles, Industrial (Item 54, WP 0188 00)

Materials/Parts

Seal, Special
 (72582)
 NSN 5330-01-105-6889
 PN 5101691
 Ring, Retaining
 (16764)
 NSN 5325-00-084-3758
 PN 274694
 Bearing, Sleeve
 (72582)
 NSN 3120-00-058-2043
 PN 5127441
 Cleaner (Item 8, WP 0187 00)

Personnel Required

Engineer 88L

DISASSEMBLE THE GOVERNOR DRIVE

1. Loosen cap screw (1) securing remote control lever (2) to shaft and lever assembly (3).

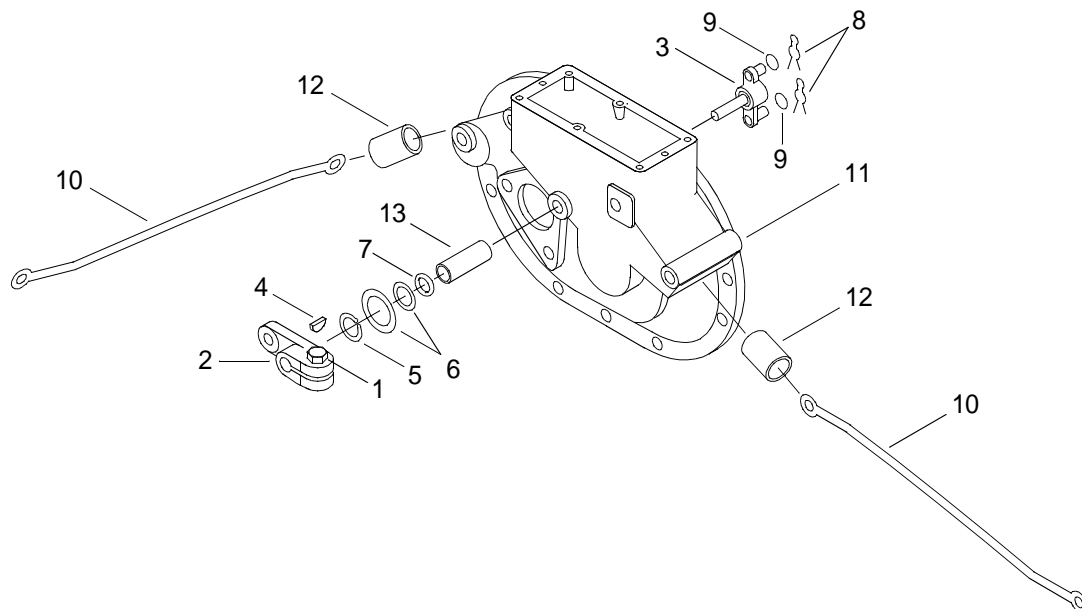

2. Remove remote control lever (2) from shaft and lever assembly (3).
3. Remove woodruff key (4) from shaft and lever assembly (3).
4. Using snap ring pliers, remove retaining ring (5) from shaft and lever assembly (3). Discard retaining ring.
5. Remove two flat washers (6) and seal ring (7) from shaft and lever assembly (3). Discard seal ring
6. Remove two pins (8) and washers (9) from shaft and lever assembly (3).
7. Remove two fuel rods (10) from shaft and lever assembly (3).
8. Slide shaft and lever assembly (3) from housing (11).
9. Using an arbor press, press out two tubes (12) from housing (11).
10. Using an arbor press, press out bushing (13) from housing (11). Discard bushing.

CLEAN THE GOVERNOR DRIVE

WARNING



CHEMICAL



EYE PROTECTION

1. Clean all parts with cleaner.

WARNING



CHEMICAL

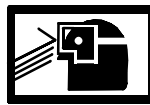

EYE PROTECTION

Do not exceed 40 PSI (279.79 kPa) when using compressed air for cleaning. Failure to comply could result in injury to personnel.

2. Dry all parts with compressed air.

INSPECT THE GOVERNOR DRIVE

1. Inspect remote control lever (2) for cracks or warping. Replace damaged remote control lever.
2. Inspect the shaft and lever assembly (3) for cracks, corrosion, pitting or warping. Replace damaged shaft and lever assembly.
3. Inspect the housing (11) for cracks or any damage that will prevent sealing. Replace damaged housing.
4. Inspect tubes (12) for cracks or dents. Replace damaged tubes.

ASSEMBLE THE GOVERNOR DRIVE

1. Using an arbor press, press new bushing (13) in housing (11).
2. Using an arbor press, press two tubes (12) in housing (11).
3. Position shaft and lever assembly (3) in housing (11).
4. Install new seal ring (7) on shaft of shaft and lever assembly (3).
5. Install two flat washers (6), small washer first, on shaft of shaft and lever assembly (3).
6. Using snap ring pliers, install retaining ring (5) on shaft of shaft and lever assembly (3).
7. Install woodruff key (4) into shaft of shaft and lever assembly (3).
8. Install remote control lever (2) on shaft and lever assembly (3).
9. Tighten cap screw (1) securing remote control lever (2) to shaft and lever assembly (3).
10. Install two fuel rods (10) through tubes (12) onto upper and lower connection of shaft and lever assembly (3).
11. Install washer (9) on each connection of shaft and lever assembly (3).
12. Install pin (8) on each connection of shaft and lever assembly (3).

END OF WORK PACKAGE

**UNIT LEVEL MAINTENANCE
CAUSEWAY FERRY
AIR INTAKE HOUSING
REMOVAL, CLEANING, INSPECTION, REPAIR AND INSTALLATION**

INITIAL SETUP:**Tools**

Tool Kit, General Mechanic's (Rail and Marine) (Item 131, WP 0188 00)
 Brush, Stencil (Soft Bristle) (Item 20, WP 0188 00)
 Apron, Utility (Item 8, WP 0188 00)
 Gloves, Chemical (Item 52, WP 0188 00)
 Goggles, Industrial (Item 54, WP 0188 00)
 Compressor Unit, Reciprocating, Power Drive (Item 27, WP 0188 00)

Materials/Parts

Packings
 (72582)
 NSN 2815-00-725-0633
 PN 5135594
 Qty 2
 Gasket
 (72582)
 NSN 5330-00-716-5634
 PN 5145086
 Cleaner (Item 8, WP 0187 00)
 Grease, Ball and Roller Bearing (Item 21, WP 0187 00)

Personnel Required

Engineer 88L

References

TM 55-1945-205-10-1

Equipment Condition

Engine Cool To Touch.
 SINCGARS Antenna Removed. (TM 11-5820-890-10-8)
 Main Navigation Mast Removed. (TM 55-1945-205-24-1-1)
 Operators Cab Removed. (TM 55-1945-205-24-1-1)
 Intake Plenum Removed. (TM 55-1945-205-24-1-1)
 Powered Section Engine Hatch Removed. (TM 55-1945-205-24-1-1)
 Emergency Stop Solenoid Removed. (WP 0176 00)

REMOVE THE AIR INTAKE HOUSING

1. Verify MAIN circuit breaker (1) on propulsion module circuit breaker panel A6 is off.

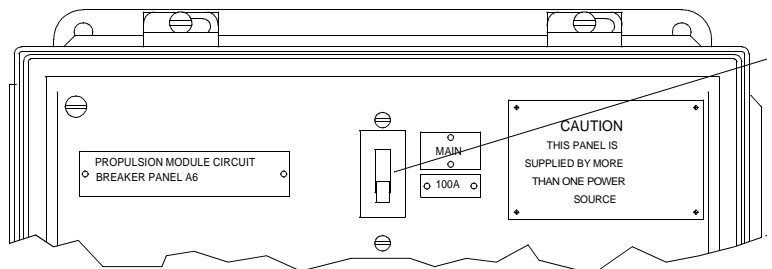

- Loosen eight band clamps (2) from Y-duct (3), angle tube (4) and four hoses (5) between the turbochargers (6) and air inlet housing (7).

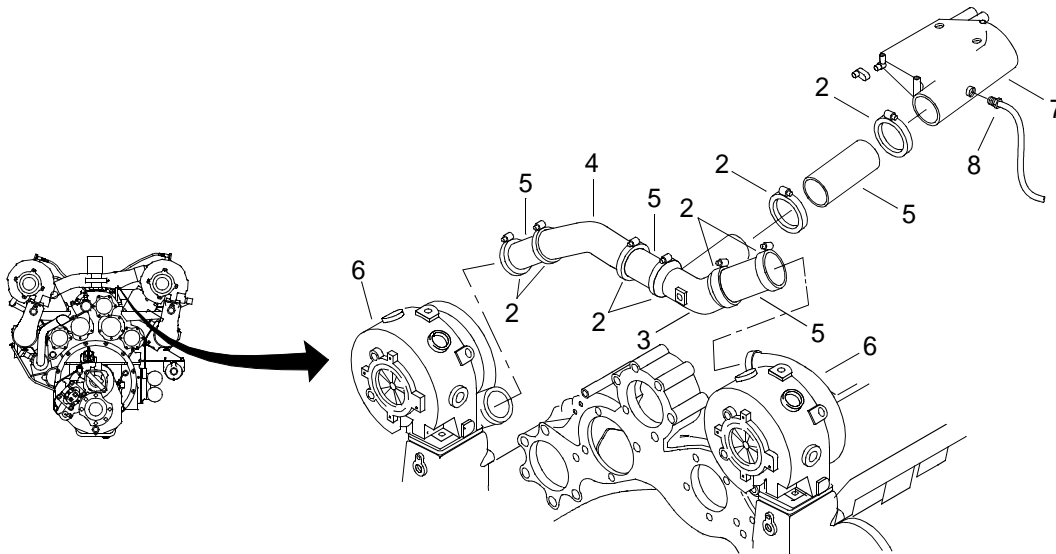

- Remove the Y-duct (3), angle tube (4) and four hoses (5) from air inlet housing (7).
- Remove cold start nozzle fitting (8) from air inlet housing (7).
- Remove six bolts (9), six lock washers (10) and six flat washers (11) securing the air inlet housing (7) to blower (12).

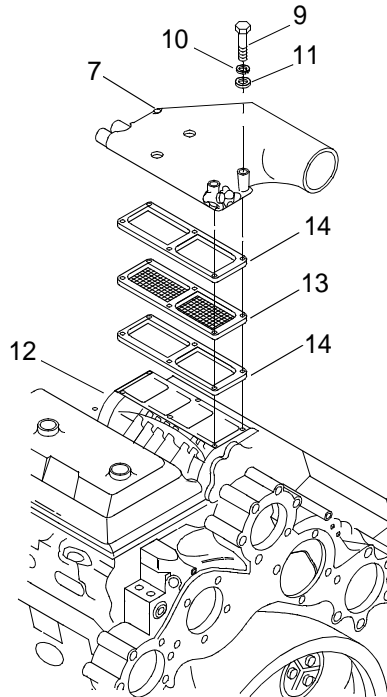

- Remove air inlet housing (7), blower screen (13) and two blower screen gaskets (14).
- Discard blower screen (13) and blower gaskets (14).

DISASSEMBLE AIR INTAKE HOUSING**NOTE**

Make note of the position of the springs and valve assembly before removing from the housing.

1. Remove bolt (15), washer (16), bushing (17), latch (18) and spring (19) from air inlet housing (7).

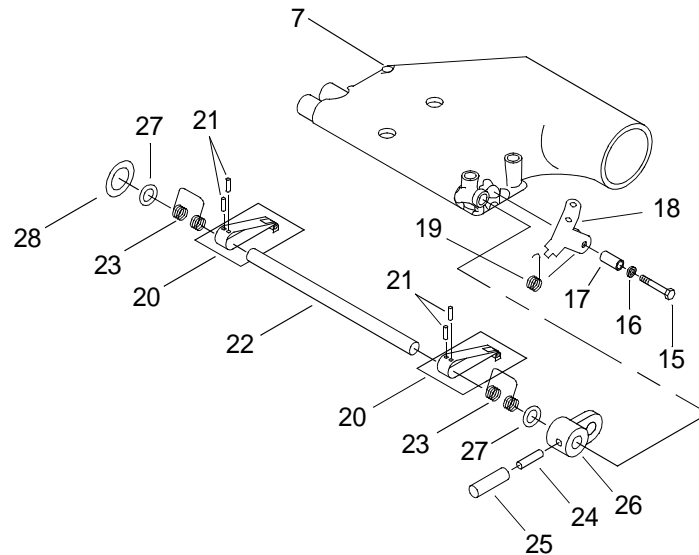

2. Turn air inlet housing (7) over to expose the valve assembly (20).
3. Remove four pins (21) attaching each valve assembly (20) to the shaft (22).
4. Remove the springs (23) and the valve assemblies (20) from the air intake housing (7).
5. Remove the shaft (22) from the air intake housing (7).
6. Remove retaining pin (24) and handle (25) from cam (26).
7. Remove the cam (26) from the shaft (22).
8. Remove the packings (27) from the shaft (22) and discard packings (27).
9. Remove washer (28) from the intake housing (7).

CLEAN AND INSPECT AIR INTAKE HOUSING**WARNING****CHEMICAL****EYE PROTECTION**

1. Using type II cleaner, clean all parts of dirt and grease.

WARNING

**EYE PROTECTION**

When drying parts with compressed air, do not exceed 40 PSI (279.79 kPa). Failure to comply could cause injury to personnel and may damage parts.

2. Dry parts with compressed air of not more than 40 PSI (279.79 kPa).
3. Inspect valve (20) for wear, cracks or distortion. Replace damaged parts.
4. Inspect all remaining parts for wear, cracks or distortion. Replace damaged parts.

ASSEMBLE AIR INTAKE HOUSING

1. Install washer (28) in the intake housing (7).
2. Install the new packing (27) on the cam end of the shaft (22).
3. Install the cam (26) on the shaft (22).
4. Install the retaining pin (24) and handle (25) on the cam (26).

WARNING

**CHEMICAL****EYE PROTECTION**

5. Using grease, lightly lubricate the shaft (22).
6. Position the springs (23) and the valve assemblies (20) in the housing (7) in the same position as noted during disassembly.
7. Install the shaft (22), through the air intake housing (7), going through the springs (23) and valve assemblies (20).
8. Install the new packing (27) on the end of the shaft (22).
9. Verify shaft end (22) seats firmly in housing (7).
10. Install four pins (21) in each of the valve assemblies (20) to secure them to the shaft (22).
11. Install bolt (15), washer (16), bushing (17), latch (18) and spring (19) in air inlet housing (7).

INSTALL AIR INTAKE HOUSING

1. Position new gasket (14) over the blower (12) and align the mounting holes.

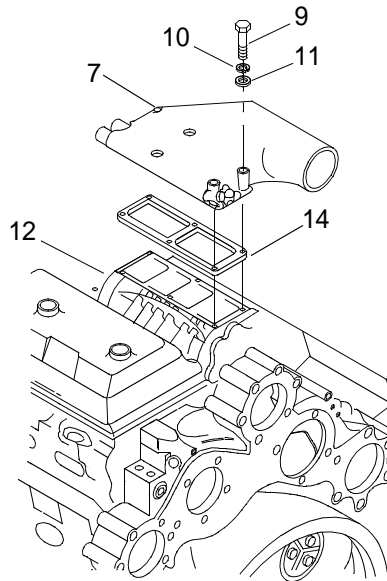

2. Position the intake housing (7) over the gasket (14) and align mounting holes.
3. Install six bolts (9), lock washers (10) and flat washers (11) through the air intake housing (7) into the blower (12).
4. Install cold start nozzle fitting (8) in air inlet housing (7) and tighten fitting (8).
5. Connect Y-duct (3), angle tube (4), four hoses (5) and eight band clamps (2) between the air inlet housing (7) and turbochargers (6).

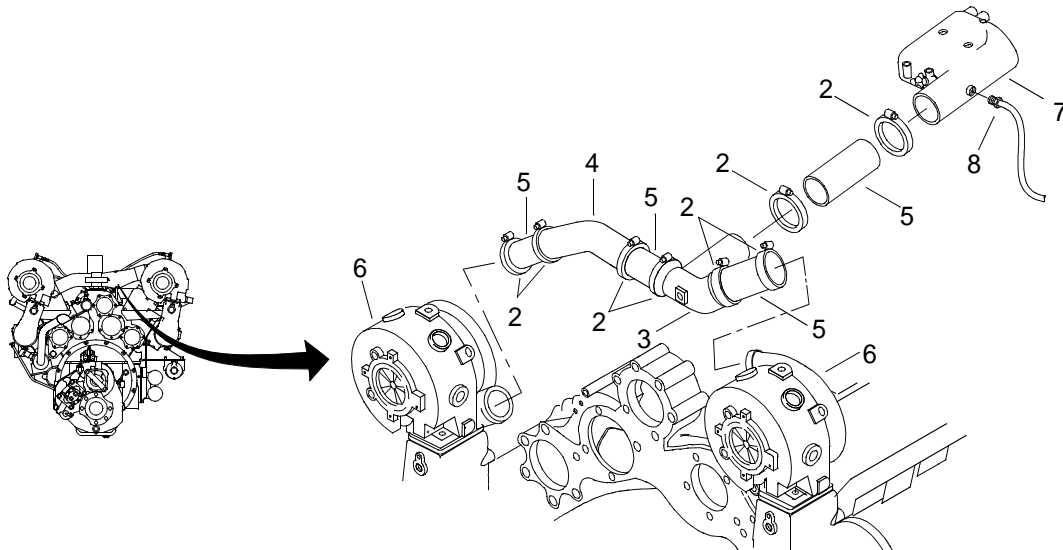

6. Tighten band clamps (2).
7. Install emergency stop solenoid. (WP 0176 00)
8. Install engine hatch. (TM 55-1945-205-24-1-1)

9. Install intake plenum. (TM 55-1945-205-24-1-1)
10. Install operators cab. (TM 55-1945-205-24-1-1)
11. Install main navigation mast. (TM 55-1945-205-24-1-1)
12. Install SINGARS antenna. (TM 11-5820-890-10-8)
13. Perform operational check of diesel engine. (TM 55-1945-205-10-1)

END OF WORK PACKAGE

**UNIT LEVEL MAINTENANCE
CAUSEWAY FERRY
AIR INLET COLLECTOR ASSEMBLY
REMOVAL AND INSTALLATION**

INITIAL SETUP:**Tools**

Tool Kit, General Mechanic's (Rail and Marine) (Item 130, WP 0188 00)

Personnel Required

Engineer 88L

References

TM 55-1945-205-10-1

Equipment Condition

Crankcase Breather Limiter Removed. (WP 0106 00)

REMOVE AIR INLET COLLECTOR ASSEMBLY**NOTE**

The following procedure is typical for removal and installation of both air inlet collector assemblies on the port and starboard engines.

1. Disconnect drain hose (1) from collector assembly (2).

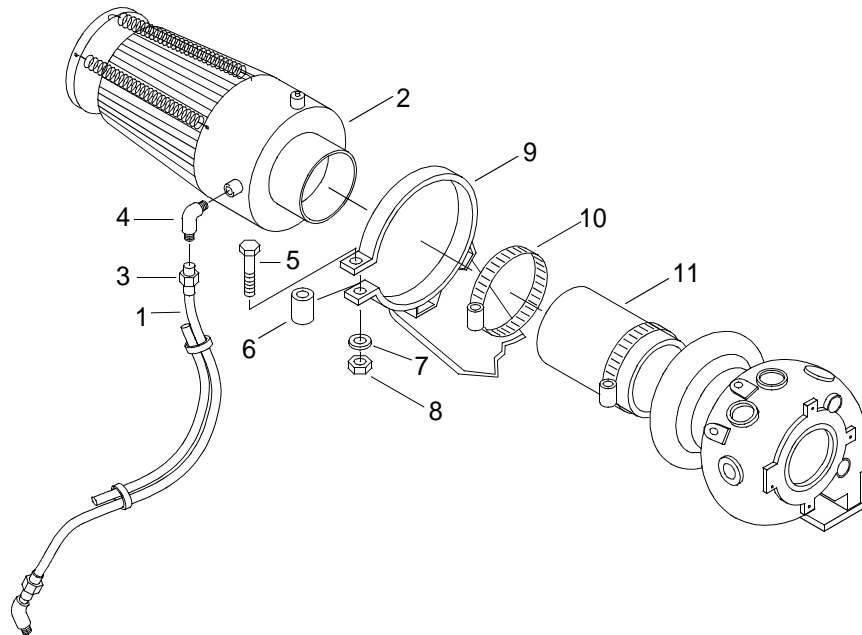

- a. Disconnect hose connector (3) from elbow (4).
 - b. Move hose (1) away from elbow (4).
 - c. Remove elbow (4) from collector assembly (2).
2. Loosen bolt (5), spacer (6), lock washer (7) and nut (8) that secure collector assembly (2) in band (9).

3. Loosen clamp (10) securing collector assembly (2) to hose (11).
4. Slide collector assembly (2) out of band (9).

INSTALL AIR INLET COLLECTOR ASSEMBLY

1. Slide collector assembly (2) into band (9).
2. Install clamp (10) and hose (11) on collector assembly (2).
3. Tighten clamp (10) on hose (11) and collector assembly (2).
4. Insert spacer (7) and tighten bolt (5), lock washer (8), and nut (9) to secure band (10) to collector assembly (2).
5. Connect drain hose (1) to collector assembly (2).
 - a. Install elbow (4) on collector assembly (2).
 - b. Install hose connector (3) onto elbow (4).
6. Install crankcase breather limiter. (WP 0106 00)
7. Perform operational check of diesel engine. (TM 55-1945-205-10-1)

END OF WORK PACKAGE

**UNIT LEVEL MAINTENANCE
CAUSEWAY FERRY
AIR INLET COLLECTOR ASSEMBLY
REPAIR**

INITIAL SETUP:**Tools**

Tool Kit, General Mechanic's (Rail and Marine) (Item 131, WP 0188 00)
 Brush, Stencil (Soft Bristle) (Item 20, WP 0188 00)
 Apron, Utility (Item 8, WP 0188 00)
 Gloves, Chemical (Item 52, WP 0188 00)
 Goggles, Industrial (Item 54, WP 0188 00)
 Compressor Unit, Reciprocating, Power Drive (Item 27, WP 0188 00)

Materials/Parts

Cleaner, Air
 (72582)
 NSN 2940-00-137-4344
 PN 23508034
 Filter Cleaning Kit
 (72582)
 PN DDF9000
 Cleaner (Item 8, WP 0187 00)
 Cloth, Cleaning (Item 13, WP 0187 00)

Personnel Required

Engineer 88L

DISASSEMBLE AIR COLLECTOR ASSEMBLY

WARNING



EYE PROTECTION

NOTE

This task is typical for both port and starboard engines.

1. Remove two retainer springs (1) holding the air filter element (2) onto the air collector assembly (3).

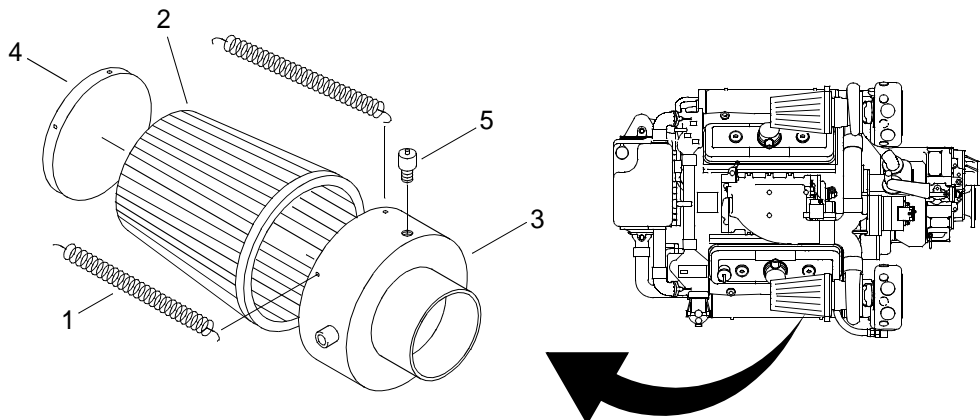

2. Remove plate (4).
3. Remove the air filter element (2).

CAUTION

Unscrew the plastic air restriction gauge by hand. Do not use tools of any kind on the air restriction gauge. Failure to comply will result in damage to the air restriction gauge.

4. Remove the air restriction gauge (5).

CLEAN AIR FILTER

WARNING

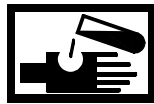

CHEMICAL

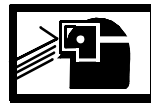

EYE PROTECTION

1. Using cleaner, clean retainer springs (1), collector assembly (3), plate (4) and air restriction gauge (5).

WARNING



EYE PROTECTION

Do not exceed 40 PSI (279.79) when using compressed air for drying components. Failure to comply may result in serious injury to personnel.

2. Using compressed air, dry retainer springs (1), collector assembly (3), plate (4) and air restriction gauge (5).
3. Tap the filter element (2) to loosen and dislodge any large, embedded particles or dirt.
4. Gently brush the filter element (2) with a soft bristle brush

WARNING

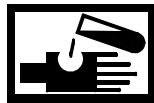

CHEMICAL



EYE PROTECTION

5. Using filter cleaning kit, clean air filter element (2).
6. Rinse off filter element (2) with low pressure water.

CAUTION

Do not use compressed air or heat dryers to dry the filter element as damage to the element will result.

7. Shake off excess water and allow filter element (2) to air dry. Placing in sunlight is allowable.

INSPECT AIR CLEANER FILTER

1. Inspect the exterior and interior of filter element (2) for excessive amounts of dirt or other foreign particles that may have remained after cleaning. Reclean, if necessary. If stubborn, residual dirt cannot be removed with follow-up cleaning, replace filter element.
2. Inspect filter element for rips or tears in screening or cotton fiber filter core. Replace defective part.

ASSEMBLE AIR COLLECTOR ASSEMBLY

WARNING

**CHEMICAL****EYE PROTECTION**

CAUTION

Never use motor oil, transmission fluid, diesel fuel or WD-40 to oil the filter element.

1. Coat filter element (3) with oil from filter cleaning kit.
 - a. Using filter cleaning kit, apply a small amount of oil across the top of each pleat.
 - b. Allow oil to wick into the filter element (2) for twenty minutes.
 - c. Apply oil to any white spots.
2. Position air filter cleaner (2) on collector assembly (3).
3. Install the plate (4) and two retainer springs (1) on opposite sides of the filter element to hold filter element (2) in place.
4. Install remaining retainer springs (1).
5. Install the air restriction gauge (5) into the collector assembly (3).

END OF WORK PACKAGE

**UNIT LEVEL MAINTENANCE
CAUSEWAY FERRY
CRANKCASE BREATHER LIMITER ASSEMBLY
REPLACEMENT**

INITIAL SETUP:**Tools**

Tool Kit, General Mechanic's (Rail and Marine) (Item 130, WP 0188 00)

Materials/Parts

Limiter Assembly
(72582)
PN 23509665
Qty 2

Personnel Required

Engineer 88L

References

TM 55-1945-205-10-1

REMOVE LIMITER ASSEMBLY**NOTE**

The following procedure is typical for removal and installation of limiter assemblies on both sides.

1. Loosen six clamps (1) connecting limiter assembly (2), three hose assemblies (3) and tube (4), to air inlet collector (5) and crankcase breather (6).

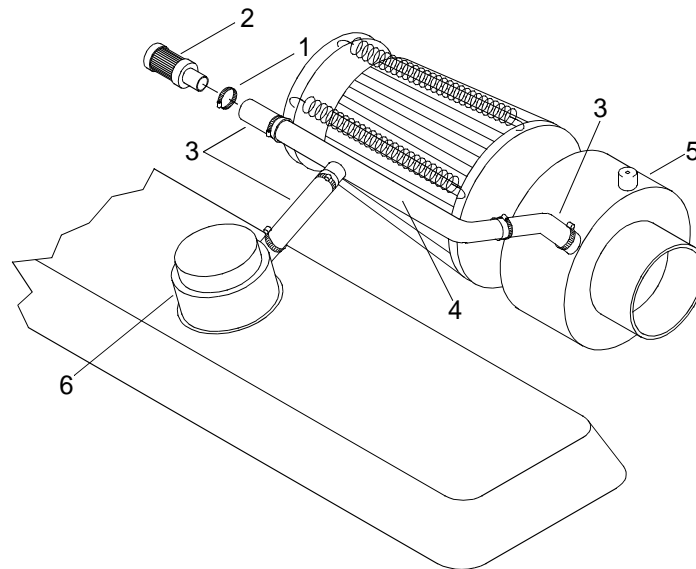

2. Remove limiter assembly (2) and discard.
3. Disconnect two hoses (3) from air inlet collector (5) and crankcase breather (6).
4. Remove three hoses (3) from tube (4).

5. Remove six hose clamps (1).

INSPECT CRANKCASE BREATHER LIMITER ASSEMBLY

1. Inspect clamps (1) for stretching, distortion, or damage. Replace damaged parts.
2. Inspect hoses (3) for wear, cuts and dry rotting. Replace damaged parts.
3. Inspect tube (4) for cracks, dents or damage. Replace damaged parts.

INSTALL LIMITER ASSEMBLY

1. Install six hose clamps (1) on hoses (3).
2. Install three hoses (3) on tube (4).
3. Connect hoses (3) and tube (4) to air inlet collector (5) and crankcase breather (6).
4. Install new limiter assembly (2).
5. Tighten six hose clamps (1).
6. Perform operational check of diesel engine. (TM 55-1945-205-10-1)

END OF WORK PACKAGE

**DIRECT SUPPORT MAINTENANCE
CAUSEWAY FERRY
CRANKCASE VENTILATION BREATHER PIPE
REPLACEMENT**

INITIAL SETUP:**Tools**

Tool Kit, General Mechanic's (Item 130, WP 0188 00)

Materials/Parts

Tube Assembly
(72582)
NSN 4710-01-160-8268
PN 5104817

Tube
(72582)
NSN 4710-01-160-8267
PN 5104816

Hose
(72582)
NSN 4720-01-128-7830
PN 5104960

Hose
(72582)
NSN 4720-01-128-7829
PN 5104959

Elbow
(72582)
NSN 4730-01-160-8269
PN 5104591

Personnel Required

Engineer 88L

References

TM 55-1945-205-10-1

Equipment Condition

SINGARS Antenna Removed. (TM 11-5820-890-10-8)
Main Navigation Mast Removed. (TM 55-1945-205-24-1-1)
Intake Plenum Removed. (TM 55-1945-205-24-1-1)
Operators Cab Removed. (TM 55-1945-205-24-1-1)
Powered Section Engine Hatch Removed. (TM 55-1945-205-24-1-1)
Engine Cool To Touch.
Crankcase Breather Limiter Assembly Removed. (WP 0106 00)
Air Inlet Collector Assembly Removed. (WP 0104 00)
Cylinder Head Poppet Valve Rocker Arm Covers Removed. (WP 0043 00)
Fresh Water Cooling System Drained. (WP 0134 00)
Fresh Water Cooling System Bypass Hose Removed. (WP 0148 00)
Fuel Pump Removed. (WP 0094 00)
Air Intake Housing Removed. (WP 0103 00)
Tachometer Sending Unit Removed (WP 0173 00)
Blower Shaft And Spring Assembly Removed. (WP 0109 00)
Electronic Governor Rod Assembly Removed. (WP 0097 00)
Electronic Governor Actuator Removed. (WP 0098 00)
Blower Removed. (WP 0110 00)

REMOVE CRANKCASE VENTILATION BREATHER PIPES

1. Remove two socket head screws (1) and lock washers (2) from pipe (3).

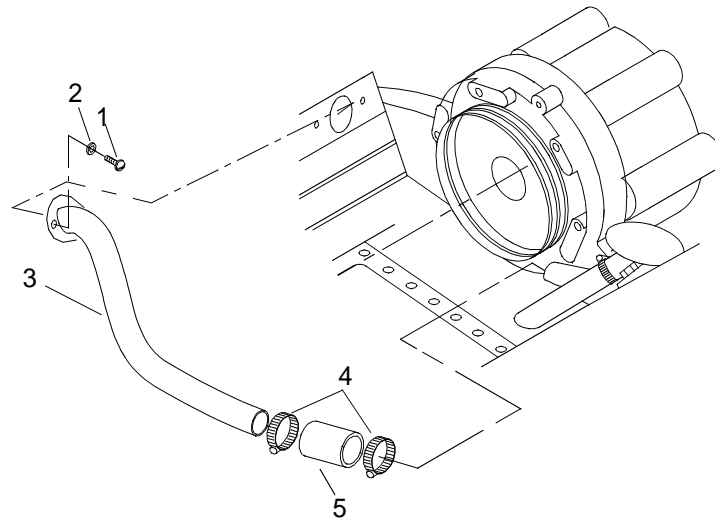

2. Remove two hose clamps (4) from hose (5).
3. Remove pipe (3) and hose (5) as an assembly and discard.
4. Remove two hose clamps (6) from hose (7).

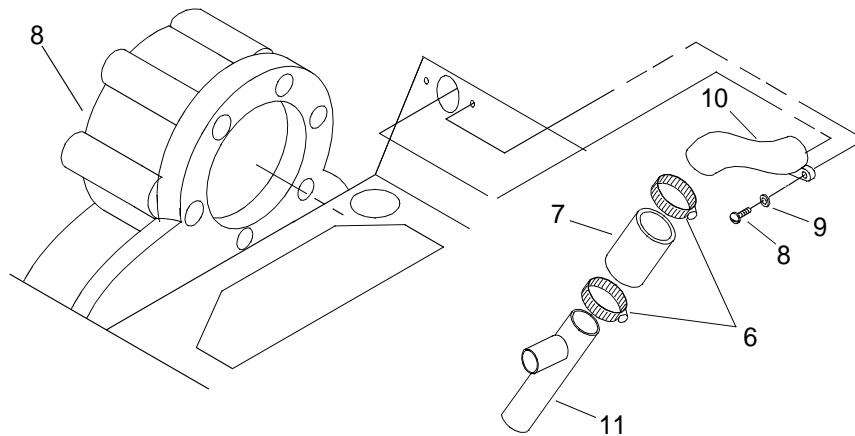

5. Remove two socket head screws (8) and lock washers (9) from elbow (10).
6. Remove pipe (11), elbow (10) and hose (7) as an assembly and discard.

INSTALL CRANKCASE VENTILATION BREATHER PIPES

1. Install new elbow (10) on new hose (7).

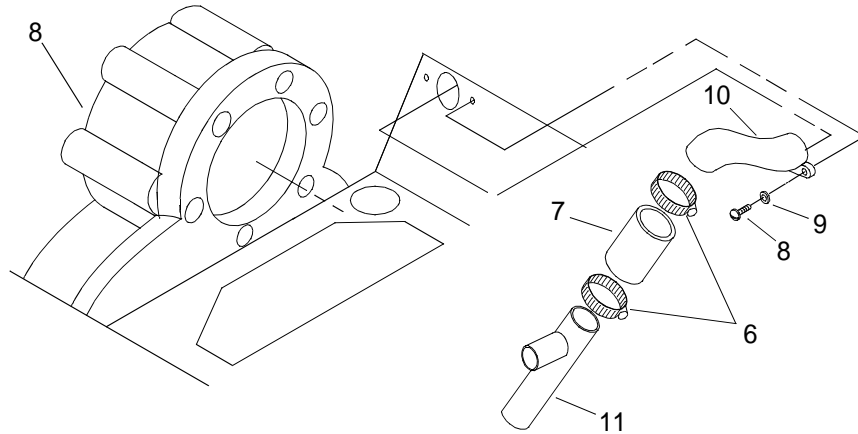

2. Install new pipe (11) on hose (7).
3. Install pipe (11), elbow (10) and hose (7) as an assembly.
4. Install two socket head screws (8) and lock washers (9) on elbow (10).
5. Install two hose clamps (6) on hose (7).
6. Install new hose (5) on new pipe (3).

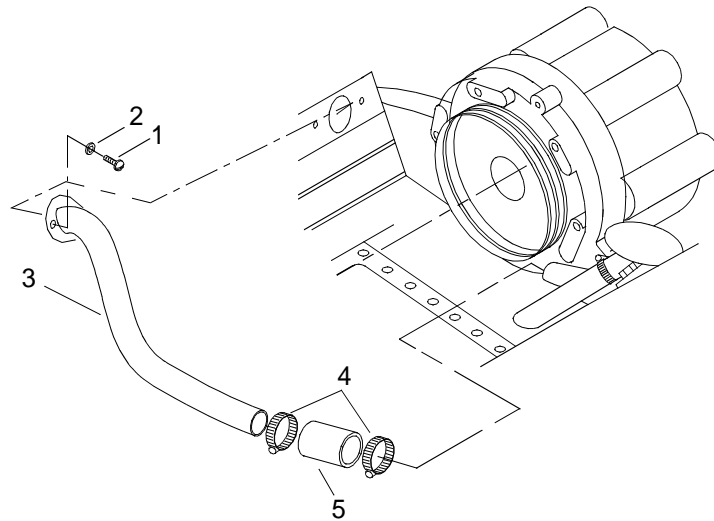

7. Install pipe (3) and hose (5) as an assembly.
8. Install two hose clamps (4) on hose (5).
9. Install two socket head screws (1) and lock washers (2) on pipe (3).
10. Install blower. (WP 0110 00)
11. Install electronic governor actuator. (WP 0098 00)

12. Install electronic governor rod assembly. (WP 0097 00)
13. Install blower shaft and spring assembly. (WP 0109 00)
14. Install tachometer sending unit. (WP 0173 00)
15. Install air intake housing. (WP 0103 00)
16. Install fuel system fuel pump. (WP 0094 00)
17. Install cylinder head poppet valve rocker arm covers. (WP 0043 00)
18. Install air inlet collector assembly. (WP 0104 00)
19. Install crankcase breather limiter assembly. (WP 0106 00)
20. Install fresh water cooling system bypass hose. (WP 0148 00)
21. Service fresh water cooling system. (WP 0133 00)
22. Install powered section engine hatch. (TM 55-1945-205-24-1-1)
23. Install operators cab or intake plenum. (TM 55-1945-205-24-1-1)
24. Install main navigation mast. (TM 55-1945-205-24-1-1)
25. Install SINGARS antenna. (TM 11-5820-890-10-8)
26. Perform operational check of diesel engine. (TM 55-1945-205-10-1)

END OF WORK PACKAGE

**DIRECT SUPPORT MAINTENANCE
CAUSEWAY FERRY
BLOWER BYPASS VALVE
REPLACEMENT**

INITIAL SETUP:**Tools**

Tool Kit, General Mechanic's (Item 130, WP 0188 00)

Materials/Parts

Valve, Safety Relief
(72582)

NSN 4820-01-305-5645
PN 23508370

Seal Ring

(72582)

NSN 5330-01-247-2375
PN 8923959

Personnel Required

Engineer 88L

References

TM 55-1945-205-10-1

Equipment Condition

Engine Cool To Touch.

REMOVE BLOWER BYPASS VALVE

1. Verify MAIN circuit breaker (1) on propulsion module circuit breaker panel A6 is off.

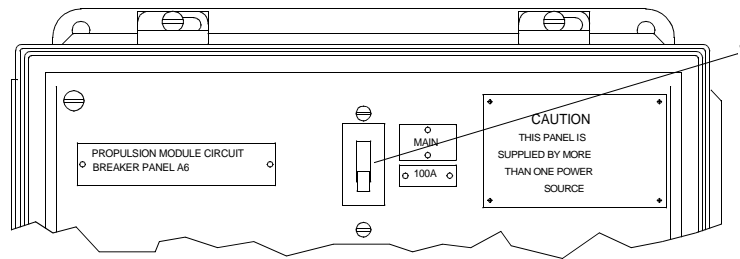

-
2. Squeeze open clamp (2) and slide back onto hose (3).

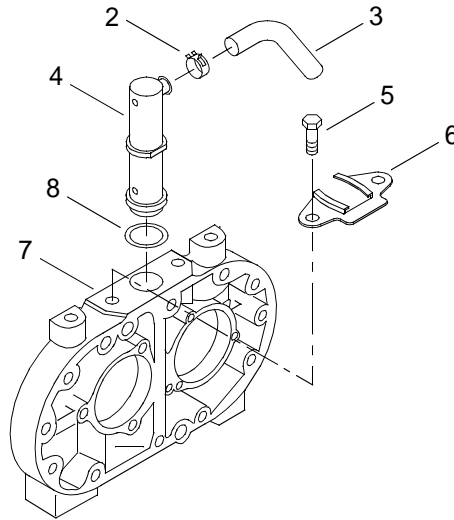

3. Remove hose (3) from valve (4).
4. Remove bolts (5) from collar (6).
5. Remove collar (6) from end plate (7).
6. Remove valve (4) from blower end plate (7) and discard valve (4).
7. Remove and discard seal (8) from blower end plate (7).

INSTALL BLOWER BYPASS VALVE ASSEMBLY

1. Install new seal (8) in blower end plate (7).
2. Push new valve (4) into blower end plate (7).
3. Install collar (4) onto blower end plate (7).
4. Install bolts (5) securing collar (6) to blower end plate (7).
5. Tighten bolts (5).
6. Install hose (3) onto valve (4).
7. Install clamp (2) over hose and valve (4).
8. Perform operational check of diesel engine. (TM 55-1945-205-10-1)

END OF WORK PACKAGE

**DIRECT SUPPORT MAINTENANCE
CAUSEWAY FERRY
BLOWER DRIVE SHAFT AND SPRING ASSEMBLY
REPLACEMENT**

INITIAL SETUP:**Tools**

Tool Kit, General Mechanic's (Item 130, WP 0188 00)
Alignment Tool, Blower Drive (Item 6, WP 0188 00)

Materials/Parts

Assembly, Shaft and Spring
(72582)
NSN 3040-01-159-7151
PN 8922634
Ring, Retaining
(72582)
NSN 5325-01-173-3437
PN 8922605
Gasket
(72582)
NSN 5330-01-088-5984
PN 5104507

Personnel Required

Engineer 88L

References

TM 55-1945-205-10-1

Equipment Condition

Engine Cool To Touch.
SINCGARS Antenna Removed. (TM 11-5820-890-10-8)
Main Navigation Mast Removed. (TM 55-1945-205-24-1-1)
Operators Cab Removed. (TM 55-1945-205-24-1-1)
Intake Plenum Removed. (TM 55-1945-205-24-1-1)
Powered Section Engine Hatch Removed. (TM 55-1945-205-24-1-1)

REMOVE BROKEN DRIVE SHAFT**NOTE**

This task contains procedures for removing both broken and unbroken blower drive shafts.

This task is typical for both port and starboard engines.

1. Remove crankcase breather limiter assembly. (WP 0106 00)
2. Remove air inlet collector assembly. (WP 0104 00)
3. Remove engine poppet valve rocker arm covers. (WP 0043 00)
4. Drain fresh water cooling system. (WP 0134 00)
5. Remove engine fresh water cooling system bypass tube. (WP 0148 00)

6. Remove fuel system fuel pump. (WP 0094 00)
7. Remove air intake housing. (WP 0103 00)
8. Remove tachometer signal generator (sending unit) (WP 0173 00)
9. Remove electronic governor rod assembly. (WP 0097 00)
10. Remove electronic governor actuator. (WP 0098 00)
11. Remove the blower. (WP 0110 00)
12. Remove portion of blower drive shaft (1) from blower drive shaft coupling (2).

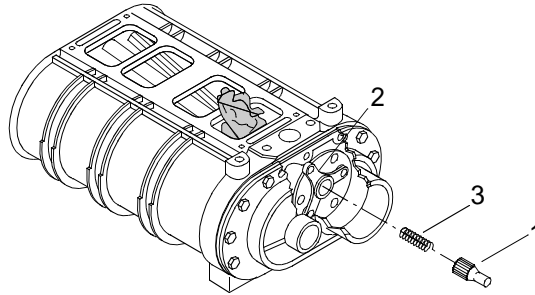

13. Remove spring (3) from blower drive shaft coupling (2).
14. Remove two nuts (4), four bolts (5) and six lock washers (6) securing blower drive shaft cover (7) to housing (8).

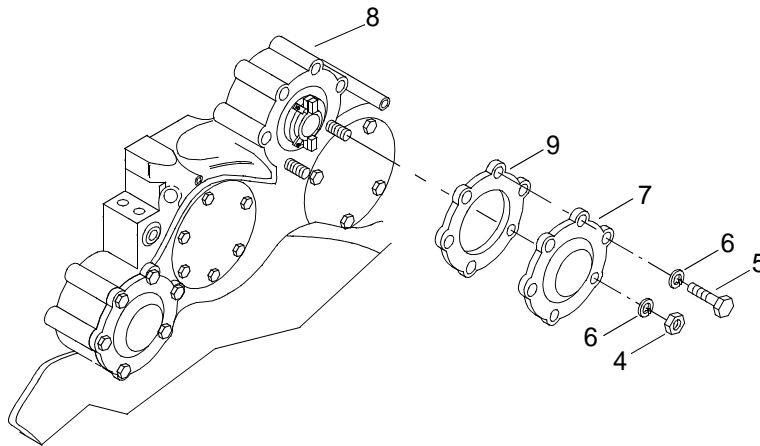

15. Remove cover (7) and gasket (9) from flywheel housing (8) and discard gasket (9).
16. Remove drive shaft retaining ring (10) from blower drive (11).

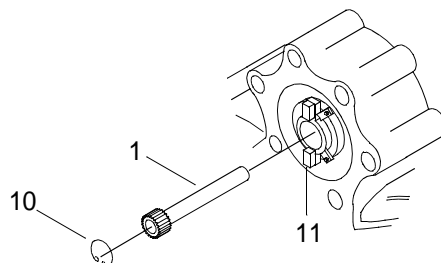

CAUTION

Do not drop spring in engine when removing drive shaft. Failure to comply could result in engine damage.

17. Install drive shaft alignment tool J33001 into blower drive shaft (1) tapped hole.
18. Slowly withdraw the other portion of blower drive shaft (1) from blower drive (11).
19. Remove drive shaft alignment tool J33001 from drive shaft (8) portion.

CAUTION

Be sure all pieces of blower drive shaft has been removed. Failure to comply could cause serious damage to the equipment

20. Inspect the area around blower drive shaft coupling (2) and blower drive (11) for small pieces of the blower drive shaft (1).
21. Discard all pieces of blower drive shaft (1).
22. Install the blower. (WP 0110 00)
23. Install electronic governor actuator. (WP 0098 00)
24. Install electronic governor rod assembly. (WP 0097 00)
25. Install tachometer signal generator (sending unit). (WP 0173 00)
26. Install air intake housing. (WP 0103 00)
27. Install fuel system fuel pump. (WP 0094 00)
28. Install engine poppet valve rocker arm covers. (WP 0043 00)
29. Install air inlet collector assembly. (WP 0104 00)
30. Install crankcase breather limiter assembly. (WP 0106 00)
31. Install fresh water cooling system bypass hose. (WP 0148 00)
32. Service fresh water cooling system. (WP 0133 00)

REMOVE UNBROKEN BLOWER DRIVE SHAFT**NOTE**

The following procedure is typical for both port and starboard engines.

1. Remove two nuts (4), four bolts (5) and six lock washers (6) securing blower drive shaft cover (7) to housing (8).

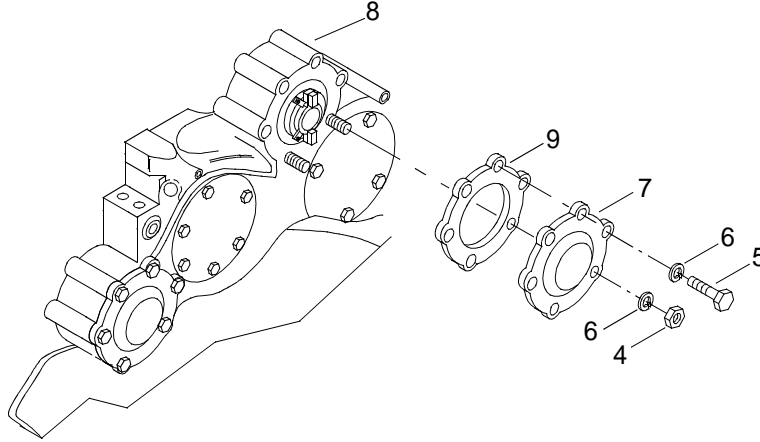

2. Remove cover (7) and gasket (9) from flywheel housing (8) and discard gasket (9).
3. Remove drive shaft retaining ring (10) from blower drive (11).

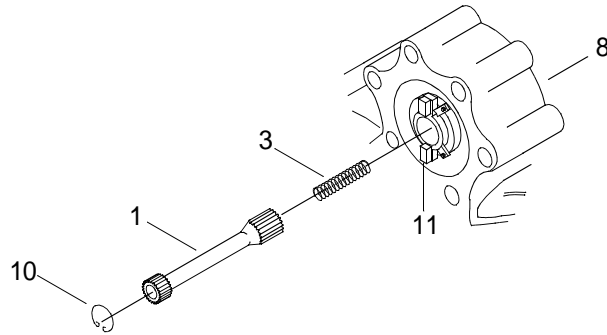
**CAUTION**

Do not drop spring in engine when removing drive shaft. Failure to comply could result in engine damage.

4. Install drive shaft alignment tool J33001 into blower drive shaft (1) tapped hole.
5. Slowly withdraw the blower drive shaft (1) and spring (3) as an assembly.
6. Remove drive shaft alignment tool J33001 from blower drive shaft (1).

INSTALL BLOWER DRIVE SHAFT

1. Install drive shaft alignment tool J33001 into hole of new blower drive shaft (8).

CAUTION

Do not drop spring in engine when installing drive shaft. Failure to comply could result in engine damage.

NOTE

The drive shaft may require rotating in order for the male splined shaft to mesh with the female splined area.

2. Slowly install the new blower drive shaft (1) and spring (3) as an assembly into blower drive (11).
3. Remove drive shaft alignment tool J33001 from blower drive shaft (1).
4. Install new drive shaft retaining ring (10) onto blower drive (11).
5. Install new gasket (9) and cover (7) onto flywheel housing (8).

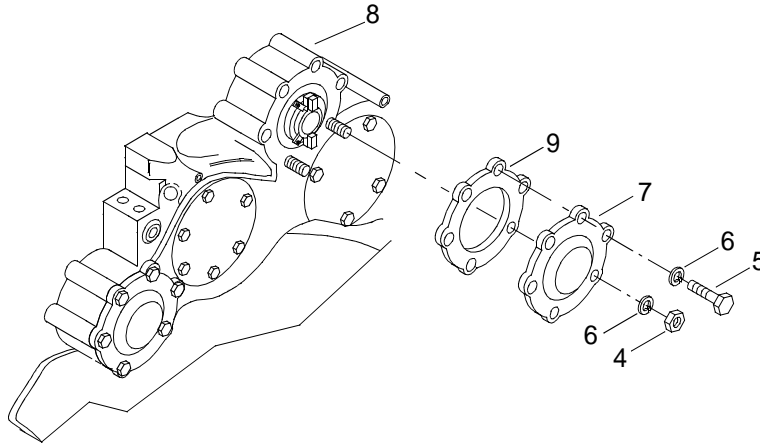

6. Install six lock washers (6), two nuts (4), and four bolts (5) to secure blower drive shaft cover (7) to flywheel housing (8).
7. Tighten nuts (4) and bolts (5).
8. Install engine hatch. (TM 55-1945-205-24-1-1)
9. Install operators cab. (TM 55-1945-205-24-1-1)
10. Install intake plenum. (TM 55-1945-205-24-1-1)
11. Install main navigation mast. (TM 55-1945-205-24-1-1)
12. Install SINCGARS antenna. (TM 11-5820-890-10-8)
13. Perform operational checks. (TM 55-1945-205-10-1)

END OF WORK PACKAGE

**DIRECT SUPPORT MAINTENANCE
CAUSEWAY FERRY
BLOWER
REMOVAL AND INSTALLATION**

INITIAL SETUP:**Tools**

Tool Kit, General Mechanic's (Item 130, WP 0188 00)
Sling 5300 lbs 6 ft (Green) (Item 118, WP 0188 00)
Bolts, Eye (Item 12, WP 0188 00)
Gloves, Chemical (Item 52, WP 0188 00)
Goggles, Industrial (Item 54, WP 0188 00)
Wrench, Torque (0-75 in. lbs) (Item 140, WP 0188 00)
Wrench, Torque (150-750 in. lbs) (Item 142, WP 0188 00)
Screwdriver Attachment Set, Socket Wrench (Item 112, WP 0188 00)

Materials/Parts

Gasket
(72582)
NSN 5330-00-915-4511
PN 23513520
Adhesive, Spray (Item 4, WP 0187 00)
Grease, Automotive and Artillery (Item 20, WP 0187 00)

Personnel Required

Engineer 88L

References

TM 55-1945-205-10-1

Equipment Condition

SINGARS Antenna Removed. (TM 11-5820-890-10-8)
Main Navigation Mast Removed. (TM 55-1945-205-24-1-1)
Operators Cab Removed. (TM 55-1945-205-24-1-1)
Intake Plenum Removed. (TM 55-1945-205-24-1-1)
Powered Section Engine Hatch Removed. (TM 55-1945-205-24-1-1)
Engine Cool To Touch.
Crankcase Breather Limiter Assembly Removed. (WP 0106 00)
Air Inlet Collector Assembly Removed. (WP 0104 00)
Cylinder Head Poppet Valve Rocker Arm Covers Removed. (WP 0043 00)
Fresh Water Cooling System Drained. (WP 0134 00)
Fresh Water Cooling System Bypass Hose Removed. (WP 0148 00)
Fuel Pump Removed. (WP 0094 00)
Air Intake Housing Removed. (WP 0103 00)
Tachometer Sending Unit Removed (WP 0173 00)
Blower Drive Shaft And Spring Assembly Removed. (WP 0109 00)
Electronic Governor Rod Assembly Removed. (WP 0097 00)
Electronic Governor Actuator Removed. (WP 0098 00)

REMOVE BLOWER ASSEMBLY

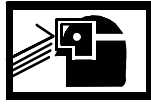
WARNING**EYE PROTECTION****NOTE**

The following procedure is typical for the removal and installation of the blower assembly for both the port and starboard engines.

1. Disconnect oil pressure line (1) fittings between blower (2) and blower drive support (3).

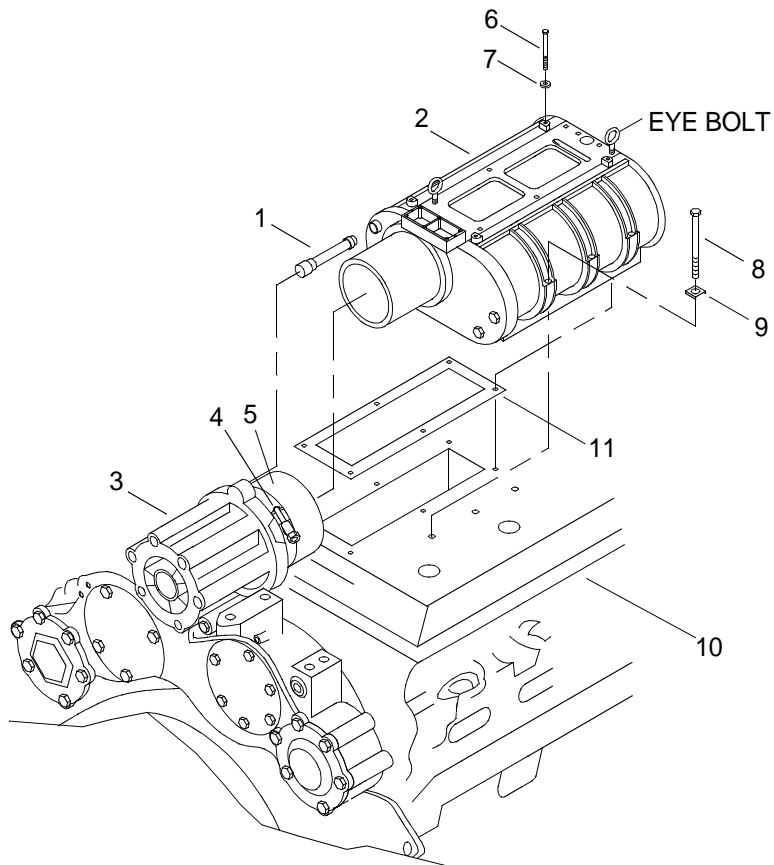
**WARNING****CHEMICAL****EYE PROTECTION**

2. Remove the oil pressure line (1).
3. Remove the hose clamp (4) on blower drive support-to-blower seal (5).
4. Remove four bolts (6) and washers (7) from top of blower (2).

5. Remove six blower-to-block bolts (8) and retaining washers (9) from sides of blower (2).
6. Install two eye bolts diagonally in top of blower (2) housing.
7. Attach sling to eye bolts.

WARNING



HEAVY PARTS

8. Using sling, lift blower (2) slightly and move forward to detach the blower (2) from blower seal (5).

WARNING



HEAVY PARTS

9. Using sling, lift blower (2) up and away from engine (10).
10. Remove sling.
11. Remove eye bolts used to lift blower (2).
12. Remove blower gasket (11) from engine (10) and discard.

INSTALL BLOWER

WARNING

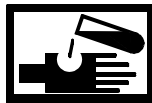

CHEMICAL



EYE PROTECTION

1. Using adhesive spray, apply to one side of new blower gasket (11).

WARNING

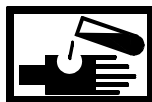

CHEMICAL



EYE PROTECTION

2. Carefully apply adhesive spray to block (10) gasket area.
3. Let adhesive set on gasket (11) and block (10) until tacky.

WARNING

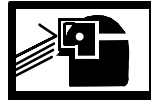
**CHEMICAL****EYE PROTECTION**

4. Install gasket (11) on block (10).

WARNING

**CHEMICAL****EYE PROTECTION**

5. Apply grease to top of gasket (11).
6. Install two eye bolts diagonally on top of blower (2) housing.
7. Attach sling to eye bolts.

WARNING

**HEAVY PARTS**

8. Using sling, lift blower (2) assembly at slight angle and position on top of engine (10) with flange of rear end plate cover inside the blower seal (5).
9. Install four long bolts (6) with washers (7) in forward and rear end plates of the blower (2). Tighten bolts finger tight.

NOTE

In the following step, the retaining washer beveled end lip is installed in the small recess in blower housing just above the bolt slot.

10. Install six blower-to-block bolts (8) with retaining washers (9) in sides of blower (2). Tighten bolts finger tight.
11. Install engine blower shaft and spring assembly. (WP 0109 00)
12. Using a torque wrench and socket set, tighten four long bolts (6) to 480 – 540 in. lbs (54.2 – 61 N-m).
13. Using a torque wrench and socket set, tighten six bolts (8) in 60 in. lbs (6.78 N-m) increments uniformly until tightened to 360 – 420 in. lbs (41.7 – 47.5 N-m).

NOTE

Blower shaft should rotate freely. If not, loosen bolts and repeat steps 7 through 9.

14. Place blower drive support-to-blower seal (5) and hose clamp (4) in position and tighten clamp (4).

WARNING

**CHEMICAL****EYE PROTECTION**

15. Connect oil pressure line (1) to the fitting in rear of blower (2) and blower drive support (3).
16. Install electronic governor actuator. (WP 0098 00)
17. Install electronic governor rod assembly. (WP 0097 00)
18. Install tachometer sending unit. (WP 0173 00)
19. Install air intake housing. (WP 0103 00)
20. Install fuel pump. (WP 0094 00)
21. Install cylinder head poppet valve rocker arm covers. (WP 0043 00)
22. Install air inlet collector assembly. (WP 0104 00)
23. Install crankcase breather limiter assembly. (WP 0106 00)
24. Install fresh water cooling system bypass hose. (WP 0148 00)
25. Service fresh water cooling system. (WP 0133 00)
26. Install powered section engine hatch. (TM 55-1945-205-24-1-1)
27. Install operators cab. (TM 55-1945-205-24-1-1)
28. Install intake plenum. (TM 55-1945-205-24-1-1)
29. Install main navigation mast. (TM 55-1945-205-24-1-1)
30. Install SINGARS antenna. (TM 11-5820-890-10-8)
31. Perform operational check of diesel engine. (TM 55-1945-205-10-1)

END OF WORK PACKAGE

**GENERAL SUPPORT MAINTENANCE
CAUSEWAY FERRY
BLOWER ASSEMBLY
REPAIR**

INITIAL SETUP:**Tools**

Tool Kit, General Mechanic's
(Item 130, WP 0188 00)
Indicator, Dial (Item 67, WP 0188 00)
Puller, Blower Gear (Item 101, WP 0188 00)
Qty 2
Remover, Blower Bearings And Adaptor
(Item 105, WP 0188 00)
Adaptor, Remover (Seal Ring Carrier)
(Item 4, WP 0188 00)
Caps, Vice Jaw (Item 24, WP 0188 00)
Expanding Snap Ring Pliers (Item 93, WP 0188 00)
Spacer Installer, To (Item 119, WP 0188 00)
Installer, Seal (Item 73, WP 0188 00)
Pilot, Blower Shaft (Item 89, WP 0188 00)
Pilot Set, Oversize (Item 88, WP 0188 00)
Insertor, Bearing and Bushing
(Item 68, WP 0188 00)
Gage Set, Thickness (Item 41, WP 0188 00)
Wrench, Torque (0-175 ft lbs)
(Item 138, WP 0188 00)
Wrench, Torque (150-750 in. lbs)
(Item 142, WP 0188 00)
Screwdriver Attachment Set, Socket Wrench
(Item 112, WP 0188 00)
Gloves, Chemical (Item 52, WP 0188 00)
Goggles, Industrial (Item 54, WP 0188 00)
Bolt, Machine, (1/4 in. x 20 x 1 1/4 in.)
(Item 16, WP 0188 00)
Qty 6
Bolt, Machine, (5/16 in. x 24 x 1 1/2 in.)
(Item 14, WP 0188 00)
Qty 5

Materials/Parts

Gasket
(72582)
PN 8924266
Seal, Oil
(72582)
PN XXXX
Qty 4
Assembly, Bearing
(72582)
PN 23503542
Qty 4
Assembly, Rotor
(72582)
PN 23503028
Assembly, Rotor
(72582)
PN 23503029
Pin, Dowel
(72582)
PN 5150542
Qty 3
Oil, Lubricating, Engine, 40W
(Item 27, WP 0187 00)
Cloth, Cleaning (Item 13, WP 0187 00)
Cloth, Abrasive (Item 12, WP 0187 00)
Cleaner (Item 8, WP 0187 00)
Sealing Compound (Item 31, WP 0187 00)
Lumber, Softwood, Dimension (2 in. X 4 in. X 6 ft
Min Wooden Blocks) (Item 23, WP 0187 00)
Qty 2

Personnel Required

Engineer 88L (2)

DISASSEMBLE BLOWER ASSEMBLY

1. Remove nine bolts (1) and washers (2) from drive cover (3).

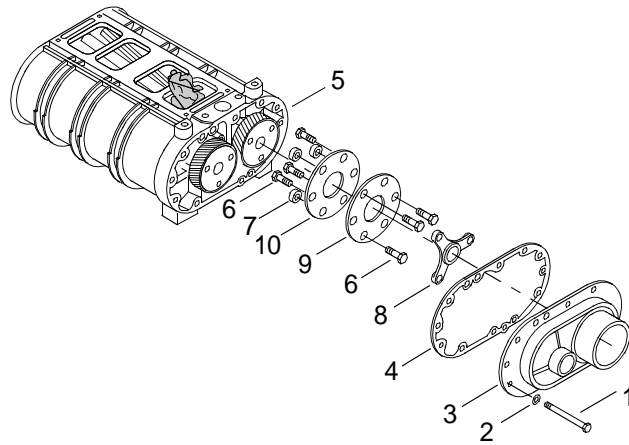

2. Remove the drive cover (3) and gasket (4) from the blower rear end plate (5).
3. Discard gasket (4).
4. Remove outer three bolts (6) and spacers (7) from blower drive coupling assembly (8).
5. Remove inner three bolts (6) and two plates (9, 10) from blower drive coupling assembly (8).
6. Place a clean folded cloth between the two rotor assemblies (11, 12).

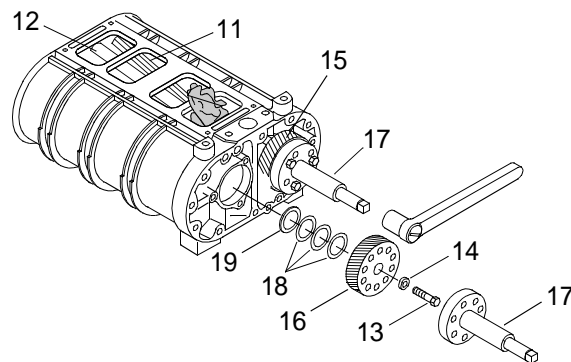

7. Remove two lock bolts (13) and spacers (14) securing timing gears (15, 16) to the rotor assemblies (11, 12).
8. Remove timing gears (15, 16).

NOTE

Both gears must be pulled at the same time.

- a. Back out the center screws of both pullers (17).
- b. Position both pullers (17) on timing gears (15, 16).
- c. Secure pullers (17) to timing gears (15, 16) with 5/16 in. X 24 X 1 ½ in. bolts.

{1} Use two bolts on the left hand timing gear (16).

{2} Use three bolts on the right hand timing gear (15).

- d. Turn two pullers (17) simultaneously clockwise and remove timing gears (15, 16) from the rotor assembly shafts (11, 12).
 - e. Remove pullers (17) from timing gears (15, 16).
9. Remove shims (18) and gear spacers (19) from the rotor assembly shafts (11, 12).

NOTE

Count the number of shims and measure the thickness to ensure an identical replacement when reassembling the blower.

10. Remove twelve self-locking screws (20, 21) securing four rotor shaft bearing retainers (22, 23) to the front end plate (24) and rear end plate (5).

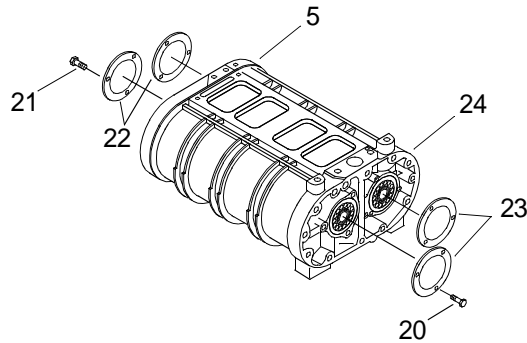

11. Remove four shaft bearing retainers (22, 23).
12. Remove blower rear end plate (5) from the blower housing (25).

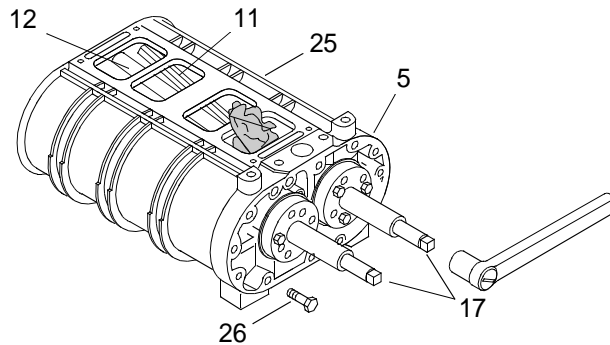

- a. Remove two fillister head screws (26) securing rear end plate (5) to blower housing (25).
- b. Back out the center screws of both pullers (17).
- c. Position both pullers (17) on rear end plate (5).

CAUTION

Ensure the six ¼ in. x 20 x 1¼ in. bolts are threaded all the way into end plate to provide maximum anchorage for the pullers to eliminate possible damage to the blower end plate.

- d. Secure pullers (17) to end plate (5) with six ¼ in. X 20 X 1¼ in. bolts.
 - e. Rotate two pullers simultaneously clockwise and remove rear end plate (5) from the blower housing (25).
 - f. Remove pullers (17) from rear end plate (5).
13. Remove front end plate (24) from blower housing (25).

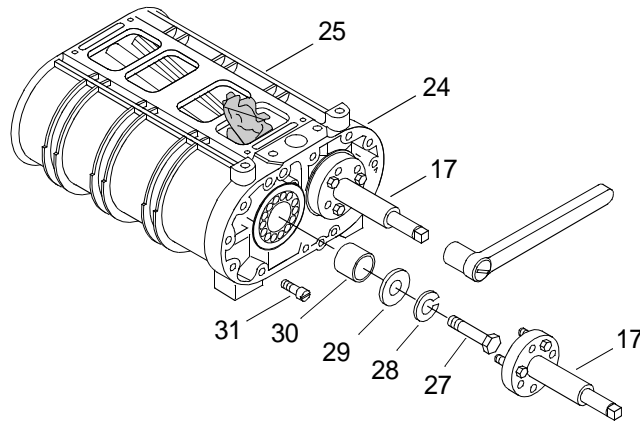

- a. Remove fuel pump drive bolt (27), lock washers (28), flat washer (29) and spacer (30).
- b. Remove two fillister head screws (31) securing front end plate (24) to blower housing (25).

NOTE

The inner races of the bearing assemblies will remain on the shaft of the rotor. The lip type oil seals will be damaged and need to be replaced with lip type oil seals or double lip type, teflon oil seals.

- c. Back out the center screws of both pullers (17).
- d. Position both pullers (17) on front end plate (24).

CAUTION

Ensure the six ¼ in. x 20 x 1¼ in. bolts are threaded all the way into the end plate to provide maximum anchorage for the pullers to eliminate possible damage to the blower end plate.

- e. Secure the pullers (17) to front end plate (24) with six ¼ in. X 20 X 1¼ in. bolts.
 - f. Rotate two pullers simultaneously clockwise and remove end plate (24) from the blower housing (25).
 - g. Remove pullers (17) from front end plate (5).
14. Remove cloth from between rotors. (11,12)

15. Remove blower rotors (11, 12) from the blower housing (25).

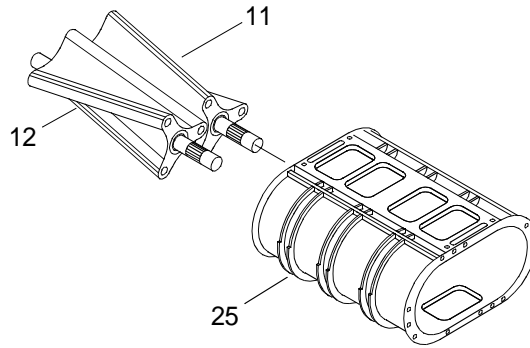

16. Remove bearings (32), oil seals (33), and ring collars (34) from the end plates (5, 24).

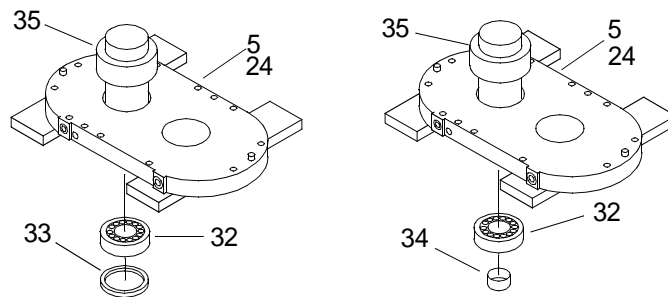

- a. Support outer ends of end plates (5, 24) on two wooden blocks on the bed of an arbor press.
- b. Place long end of the seal remover installer J 6270-3 (35) down through the oil seal (33) or ring collar (34) into bearings (32).
- c. Lower ram of the arbor press and press out bearings (32) and oil seal (33) or ring collar (34) and discard.
- d. Remove remaining three bearings and oil seals in the same manner.
- e. Discard oil seal (33) and ring collar (34).

NOTE

Step 16 is only necessary on older style seals on turbocharged blowers. Upon installation, the lip type or double lip type teflon oil seal should be used.

17. Remove seal rings (36) and seal ring carriers (37) and bearing race (38) from rotor shafts (11, 12).

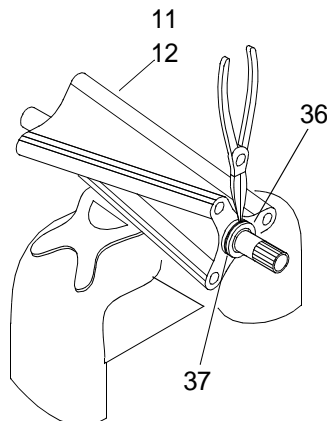

- a. Clamp one lobe of a rotor (11, 12) in a vice equipped with two soft jaw vice caps tightened only enough to hold the rotor (11, 12) stationary.
- b. Remove oil seal ring (36) from the seal ring carrier (37) with a pair of expanding snap ring pliers.
- c. Place seal ring carrier remover adaptor (39) over the seal ring carrier (37) ensuring the adaptor is seated securely into the groove of the seal ring carrier (37).

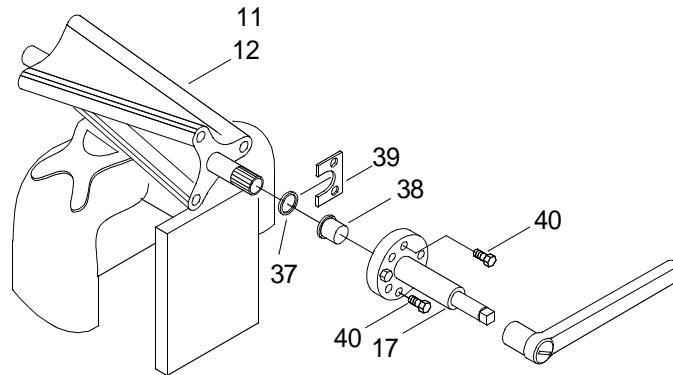

- d. Back out center screw of puller (17) far enough to permit the puller flange to lay flat against adaptor J 6270-2.
- e. Place puller over the rotor shaft (11, 12) against the adaptor and secure puller (17) to adaptor with two bolts (40) provided with the adaptor.
- f. Rotate the puller clockwise to remove the oil seal ring carrier (37) and bearing races (38) from the rotor shafts (11, 12).
- g. Remove the remaining three oil seal ring carriers (37) and bearing races (38) from the rotor shafts (11, 12) in the same manner.
- h. Discard oil seal ring carriers (37)

INSPECT THE BLOWER PARTS

WARNING



CHEMICAL



EYE PROTECTION

1. Wash all of the blower parts in cleaner.
2. Inspect the bearing assemblies (32) for any indications of corrosion or pitting.

WARNING

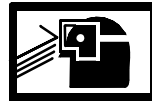
**CHEMICAL****EYE PROTECTION**

- a. Lubricate each bearing assembly (32) with clean engine oil.

NOTE

The double row ball bearings are preloaded and have no end play. A new bearing will seem to have considerable resistance to motion when revolved by hand.

- b. While holding the bearing inner race, rotate the bearing outer race slowly and check for rough spots.
 - c. Replace bearing if any corrosion, pitting, rough spots when rotating, end play or any other damage is found.
3. Inspect the blower rotor lobes (11, 12) for burrs or scoring. If the rotors are burred or scored, use abrasive cloth to remove burrs or scoring.
 4. Inspect the rotor shaft splines (11, 12) for burrs, peening or wear. Use abrasive cloth to remove burrs or peening. Replace rotors if worn.
 5. Inspect the rotor shaft seal and bearing surfaces (11, 12) for wear or scoring. Use abrasive cloth to remove burrs or scoring. Replace rotor shaft seals and bearings if worn.
 6. Inspect the inside surface of the blower housing (25) for burrs or scoring. If the inside surface is burred or scored, use abrasive cloth to remove burrs or scoring.
 7. Inspect the finished end plates of the blower housing (5, 24) for flatness and burrs.
 - a. Ensure that the end plate is set flat against the blower housing.
 - b. Ensure that the finished inside face of each end plate is smooth and flat. If the finished face is slightly scored or burred, use abrasive cloth to remove burrs or scoring.
 - c. Inspect the dowel pins to ensure they protrude 0.320 in. from the flat inner face of the end plate (5, 24). Replace as necessary.
 8. Examine the blower timing gears (15, 16).
 - a. Check timing gears for wear or peening. Use abrasive cloth to remove peening. Replace timing gears if worn.

NOTE

If required, timing gears are replaced as a set.

- b. Check timing gears for cracks, chipped teeth or other damage. Replace as necessary.
9. Check blower drive shaft splines (11, 12) for wear or peening. Replace shaft if it is bent, cracked or has spline wear.

ASSEMBLE THE BLOWER ASSEMBLY**NOTE**

Lip type oil seal will be used under normal circumstances. However if the rotor shaft seal surface is pitted or worn the oversize double lip type oil seal will be used.

Do not lubricate the seals, spacers or the blower rotor shaft prior to installing. Teflon lip seals must be installed dry. This allows transfer of teflon to all surfaces for proper sealing.

Double lip teflon seals are packaged around a plastic sleeve which should not be removed prior to installation. The sleeve protects the seal lips during shipment and acts as a seal expander during blower assembly.

1. Install the new lip type oil seals (33).

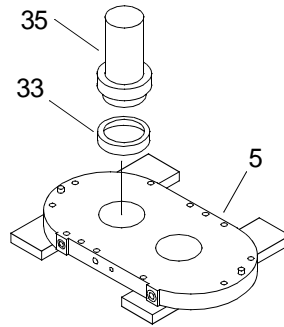

- a. Support the end plate (5, 24) on wooden blocks with the finished side facing up on the arbor press.
- b. Start the new oil seal (33) straight into the bore of the end plate (5, 24) with the sealing edge of the seal facing down.
- c. Place the short end of oil seal remover/installer J 6270-3 (35) onto oil seal (33).

NOTE

A step under the shoulder of the installer will position the oil seal approximately 0.005 in. below the finished face of the end plate. This will be within the 0.002 - 0.008 in. tolerances specified.

- d. Lower the ram of the press until the shoulder of the installer contacts end plate (5, 24).
- e. Install the remaining oil seals (33) in end plates (5, 24) using the same steps.

NOTE

If the seal surface on the Rotor shaft was worn, an oversize seal and sleeve will need to be used. If standard size seals are to be used, skip step 2.

2. Install the oversize seal (33) and sleeve (43).

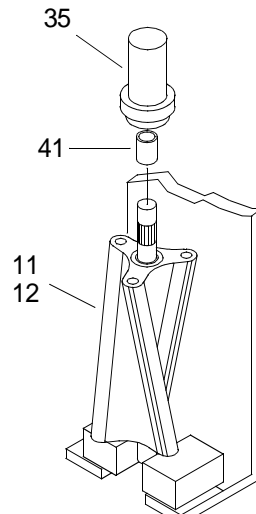

- a. On the bed of the arbor press, support rotor (11, 12) on wooden blocks with seal shaft facing up.
- b. Start the oversized seal sleeve (41) on the rotor shaft, and place seal installer (35) against the oversized seal sleeve (41).
- c. Lower the ram of the press until either the shoulder of the installer J 35787-1 or the oversized seal sleeve (41) contacts the rotors (11, 12).
- d. Install remaining oversized seal sleeves (41) on rotors (11, 12) in the same manner.
- e. Support the end plate (5, 24) on wooden blocks with the finished side facing up on the arbor press.

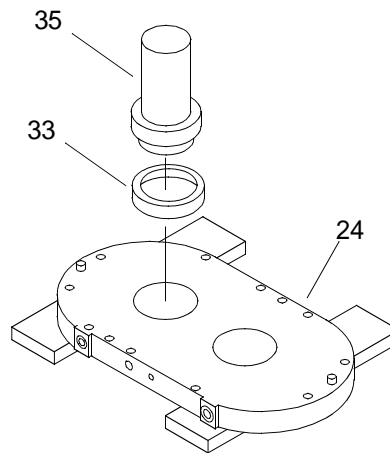

- f. With the part number on the seal facing up, start the new oil seal (33) straight into the bore of the end plate (5, 24).
- g. Using installer (35), press the double lip oil teflon oil seal into end plate (5, 24) until the shoulder of the installer contacts the end plate.
- h. Install the remaining oil seals (33) in end plates (5, 24) using the same steps.

3. Install the blower front end plate (24).

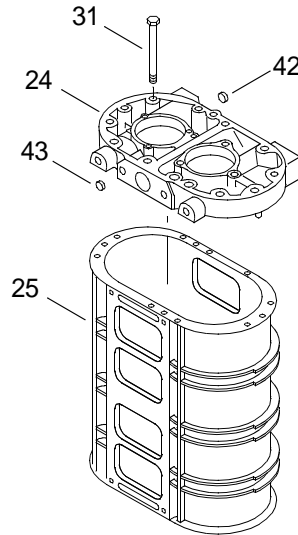

NOTE

The front end plate is thinner than the rear end plate. The top of the front end plate it has two bolt holes and only one oil hole.

- If removed, press a new oil strainer (42) in the vertical oil passage at the bottom side of the end plate (24) 0.15 in. below the bottom edge of the bottom surface.
- Install pipe plug (43) in the vertical oil passage at the top of the end plate (24).
- Place blower housing (25) on a bench with top side up and the front end facing out.

WARNING

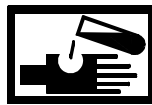

CHEMICAL



EYE PROTECTION

NOTE

No gaskets are used between the end plates and the blower housing therefore mating surfaces should be perfectly flat, smooth and clean. Ensure that there is no sealant protruding into the blower housing.

- Apply a light coat of sealing compound to the mating surfaces of both the blower housing (25) and the front end plate (24).
- Position the front end plate (24) over the front end of the blower housing (25) with the top of the end plate (24) aligned with the top of the blower housing (25).
- Push or tap the front end plate (24) all the way down against the blower housing (25), ensuring that the front end plate (24) is lying flat against the blower housing (25).

NOTE

Do not use lock washers on fillister head screws.

- g. Insert two fillister head screws (31) through the front end plate (24) and into the housing (25).
 - h. Using a torque wrench and screwdriver socket wrench set, torque fillister head screws (34) to 60 - 120 in. lbs (7 - 14 N-m).
4. Install blower rotors (11, 12) in the blower housing (25).

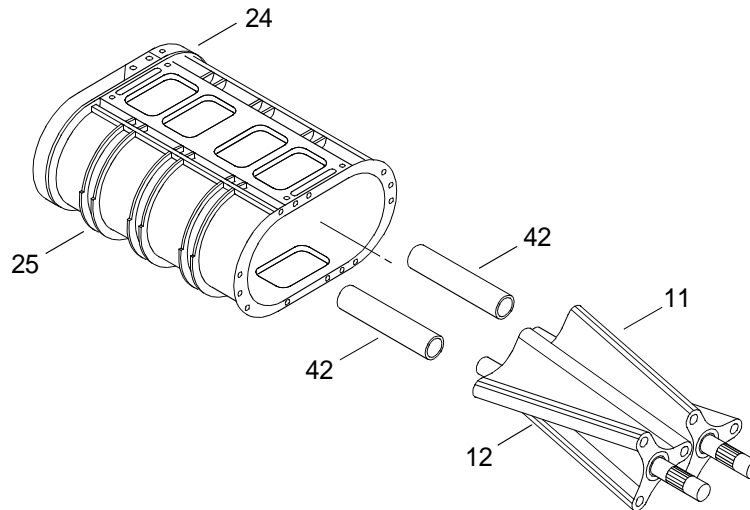

- a. Reverse the blower housing (25) so that the open end is facing out.
- b. Position the rotors (11, 12) in mesh so that both blind splines (omitted serrations) is in the are in the 9 o'clock position when viewed from the gear end.
- c. Install the oil seal pilot J 6270-5 (44) on the opposite end of the rotor shaft (11, 12). When using oversize seals, use seal pilot J 6270-28.

NOTE

The double lipped teflon oil seals are installed by the same method, except the plastic sleeve that came with the seal is reinserted. The spacer will push out the plastic sleeve permitting the seals to seat squarely on the spacer without being damaged.

- d. Insert rotors (11, 12) strait into the blower housing (25) and through the front blower end plate (24).
 - e. Remove oil seal pilots from rotor shafts.
5. Install the blower rear end plate (5).
- a. If removed, press an oil strainer (42) into the vertical oil passage at the bottom side of the end plate (5).15 in. below the bottom edge of the bottom surface.

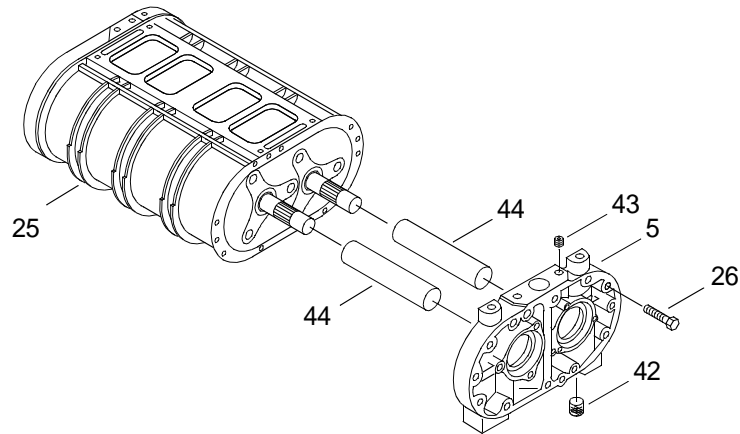

- b. Install pipe plug (43) in the vertical oil passage at the top of the end plate (5).
- c. Install an oil seal pilot (44) over the splined end of the of each rotor shaft. When using oversize seals use seal pilot J 6270-28.

WARNING



CHEMICAL

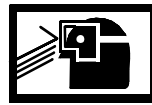

EYE PROTECTION

- d. Apply a light coat of sealing compound to the mating surfaces of both the blower housing (25) and the rear end plate (5).

NOTE

The double lipped teflon oil seals are installed by the same method, except you reinsert the plastic sleeve that came with the seal. The spacer will push out the plastic sleeve permitting the seals to seat squarely on the spacer without being damaged.

- e. Position the rear end plate (5) over the rear end of the blower housing (25) with the top of the end plate (5) aligned with the top of the blower housing (25).
- f. Push or tap the rear end plate (5) all the way down against the blower housing (25), ensuring that the front end plate (5) is lying flat against the blower housing (25).

NOTE

Do not use lock washers on fillister head screws.

- g. Insert two fillister head screws (26) through the rear end plate (5) and into the housing (25).
- h. Using a torque wrench and screwdriver socket wrench set, torque fillister head screws (34) to 60 - 120 in. lbs (7 - 14 N-m).

6. Install rear blower rotor shaft bearings (32).

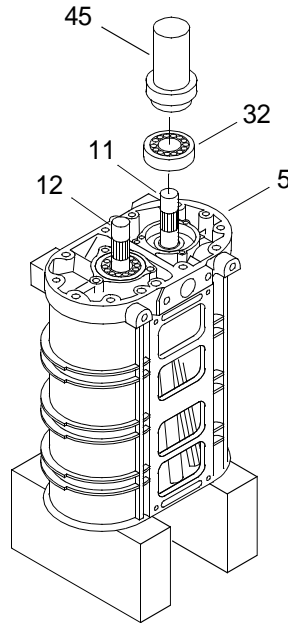

- a. Lubricate one of the ball bearings (32) with a light engine oil and start the bearing (P/N facing up) straight on one of the rotor shafts (11, 12).
 - b. Place installer (45) on top of the bearing (32) and tap until it is on the shaft of rotor (11, 12) and into the rear end plate (5).
 - c. Install the second ball bearing (32) on the other rotor shaft (11, 12) in the same manner.
7. Install front blower rotor shaft bearings (32) and races (38).

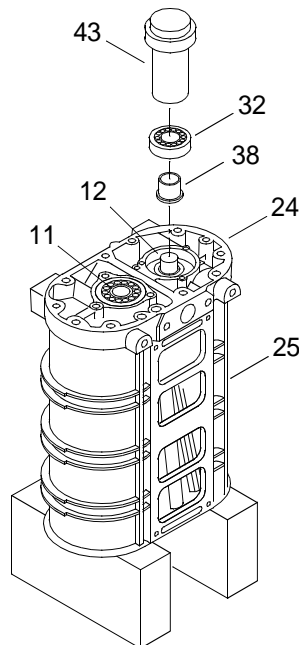

- a. Reverse the position of the blower housing (25) on two wooden blocks.

- b. Position inner bearing inner race (38) over the front end of the rotor shaft (11).
- c. Press the inner bearing race (38) on the shaft (11) with installer (45) until the bearing race contacts the shoulder of the shaft.
- d. Install the other front roller bearing race (38) on shaft (12) in the same manner.

WARNING

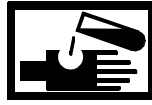

CHEMICAL

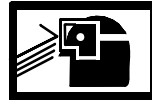

EYE PROTECTION

- e. Lubricate one of the roller bearings (32) with light engine oil.
- f. Start the bearing on the rotor shaft (11, 12) and inner race (38).
- g. Using installer (45), tap bearing (32) on to inner race (38) and into front end plate (24).
- h. Install the other bearing (32) on shaft (12) in the same manner.
- i. Place bearing retainers (22, 23) over the bearings (29) and end plates (5, 24).

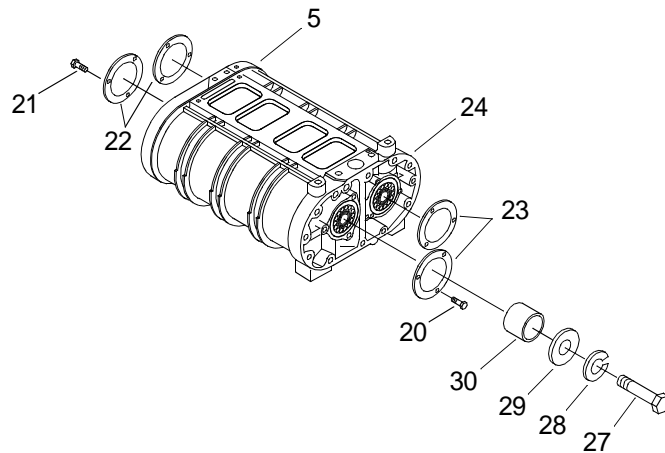

- j. Install self locking screws (20, 21).
 - k. Using torque wrench, torque self locking screws to 84 - 108 in. lbs (9 - 12 N-m)
 - l. Install the fuel pump drive bolt (27), lock washers (28), flat washer (29) and spacer (30).
8. Make preliminary checks of rotor-to-end plate and rotor-to-housing at this time with a feeler gage. (Refer to MINIMUM BLOWER CLEARANCES TABLE columns D and E)

9. Center punch a mark on each rotor shaft end (11, 12) the exact location of the blind spline and rotate so both are in the 9 o'clock position.

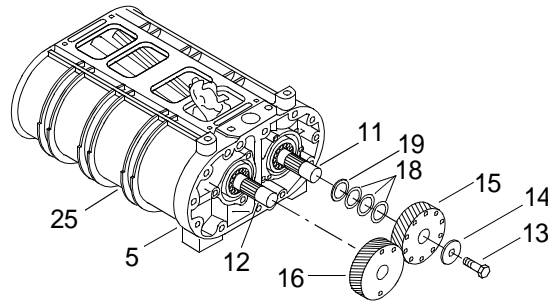

10. Place the blower on the bench right side up and the splined shafts facing out.

NOTE

If shims were removed from the blower shafts they should be replaced in their original position on their respective shafts.

11. Install a 0.140 in. thick gear spacer (19) and the same thickness of shims (18) on each rotor shaft (11, 12) that were removed at the time of disassembly.

WARNING



CHEMICAL



EYE PROTECTION

12. Lubricate the splines with light engine oil.

NOTE

Ensure the right gear is put back on the right rotor shaft and the left gear is put back on the left rotor shaft.

13. Install the rotor shaft gears (15, 16).
- Mesh the gears (15, 16) so that the splines on the gears match the splines on the rotor shafts (11, 12).
 - Start the gears (15, 16) on the rotor shafts (11, 12) at the same time so they are straight.
 - Start bolts (13) and large washers (14) on the end of each rotor shaft (11, 12).
 - Place a clean folded rag in the rotor lobes to prevent them from turning.
 - Tighten bolts slowly and at the same time to draw gears (15, 16) down at the same time until they are tight against the spacers (19), shims (18) and bearing races.
 - Remove the two bolts and washers that were used to draw the gears (15, 16) down onto the rotor shafts (11, 12).
 - Lubricate the threads of the bolts (13) and start on the rotor shafts (11, 12) with 0.340 in. thick spacers (14).

- h. Using torque wrench, torque the bolts (13) to 100 - 110 ft lbs (135.6 - 149.16 N-m).
- i. Remove the rag from the rotors.

NOTE

The positioning of the helix gears to obtain proper clearance, is known as blower timing.

14. Time the blower.

- a. To assist in holding the end plates against the blower housing, thread four 5/16-18 X 1-7/8 in. long bolts through each end plate into the blower housing.
- b. Check the clearance between the trailing edge of the right hand helix rotor and the leading edge of the left hand helix rotor 1 in. from each end and in the center. (Refer to column and position CC)

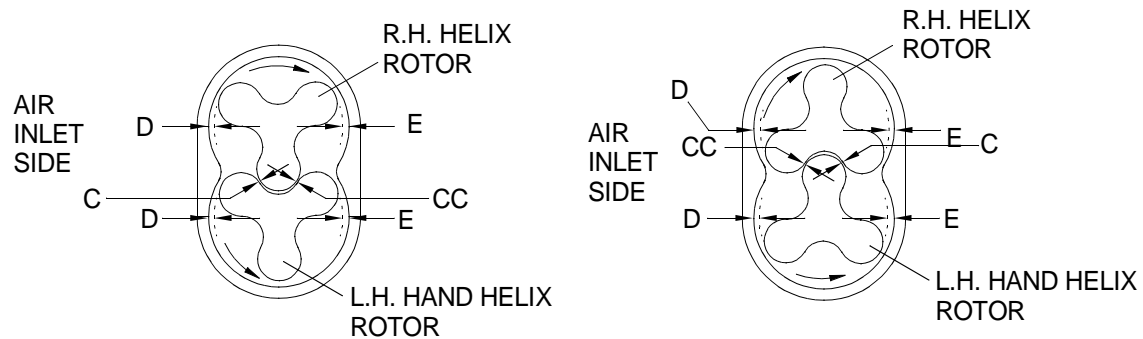

VIEWS FROM GEAR END OF BLOWER

- c. Check the clearance between the leading edge of the right hand helix rotor and the trailing edge of the left hand helix rotor 1 in. from each end and in the center. (Refer to column and position C)
- d. Determine the amount the rotors must be revolved. Placing a 0.003 in. shim behind either gear will rotate that rotor 0.001 in.

NOTE

When installing shims, gears must be removed and installed at the same time. Refer to the disassembly section of this work package to remove gears prior to adding shims, and refer to assembly section of this work package to install the gears.

- e. After determining the required amount of shims needed, remove the gears.
- f. Install the shims (18) behind gears (15, 16) in front of gear spacers (19).
- g. Install the gears.
- h. Check the clearances between the rotor lobes.

- i. Check the minimum clearances between both end plates (5, 24) and the end of each lobe (11, 12), twelve measurements in all. (Refer to columns A and B for clearances)

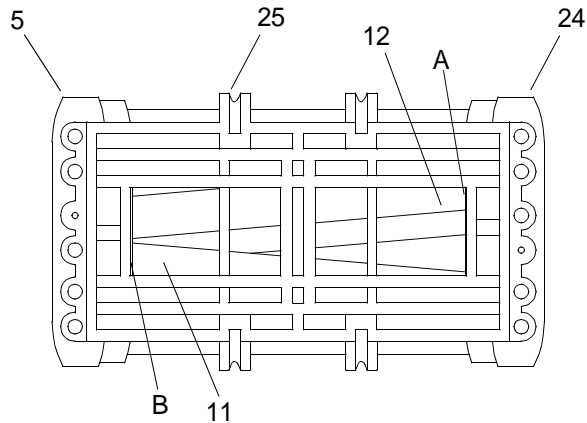

- j. Check the clearance between each rotor lobe (11, 12) and the housing (25) at both the inlet and the outlet, twelve measurements in all. (Refer to columns D and E for clearances)
15. Check timing gears (15, 16) backlash by measuring the clearance between the two gears not to exceed 0.004 in. using a dial indicator. If measurement exceeded, replace the timing gears as a set.
 16. Install bolts (6) and flex plates (9, 10) on blower drive coupling (8).

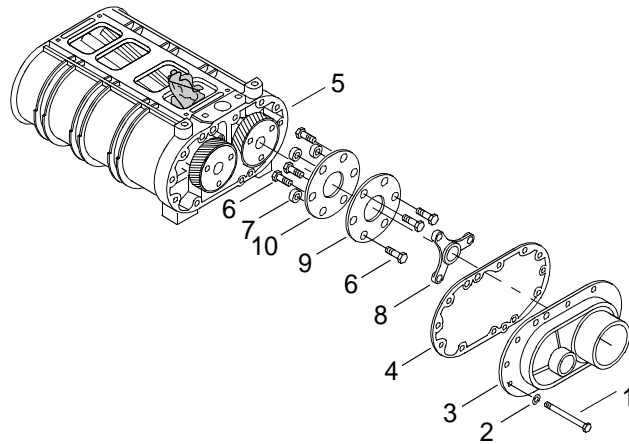

17. Install three bolts (6) and spacers (7) on blower drive.
18. Install the drive cover (3) and gasket (4) on the blower.
19. Install bolts (1) and washers (2) in the drive cover (3).

Table 1. Chart of Minimum Blower Clearances.

BLOWER PART NO.	ENGINE	CLEARANCES					
		A	B	C	CC	D	E
5101483	8V-TA	0.007	0.019	0.010	0.006	0.015	0.005
5101484	8V-TAE	0.007	0.019	0.010	0.006	0.015	0.005
5104937	8V	0.007	0.019	0.010	0.006	0.015	0.005
5144787	8V	0.007	0.014	0.010	0.006	0.015	0.005
5144893	8V	0.007	0.014	0.010	0.006	0.015	0.005
5146912	8V	0.007	0.012	0.010	0.006	0.015	0.005
5147152	8V	0.012	0.019	0.010	0.006	0.030	0.005
8920613	8V-TAE	0.007	0.019	0.010	0.006	0.015	0.005
8921938	8V-TA	0.007	0.019	0.010	0.006	0.015	0.009
8923371	8V-TAE	0.007	0.019	0.010	0.006	0.015	0.005
8923474	8V-TA	0.007	0.019	0.010	0.006	0.015	0.007
8923475	8V-TA	0.007	0.019	0.010	0.006	0.015	0.007
8923476	8V-TA	0.007	0.019	0.010	0.006	0.015	0.007
8926407	8V-TA	0.007	0.012	0.010	0.006	0.015	0.005
8926408	8V-TA	0.007	0.019	0.010	0.006	0.015	0.005
8926616	8V-TA	0.007	0.019	0.010	0.006	0.015	0.005
8927037	8V-TA	0.007	0.019	0.010	0.006	0.015	0.007
8927041	8V-TA	0.007	0.019	0.013	0.013	0.015	0.009
8927043	8V-TA	0.007	0.019	0.010	0.006	0.015	0.007
8927468	8V-TA	0.007	0.019	0.010	0.006	0.015	0.009
23501076	8V-TA	0.007	0.012	0.010	0.010	0.015	0.007
23501261	8V-TA	0.007	0.019	0.010	0.006	0.015	0.009
23501842	8V-TA	0.007	0.019	0.010	0.010	0.015	0.009
23503027	8V,	0.010	0.019	0.025	0.013	0.015	0.009
23503651	8V-TA	0.007	0.019	0.013	0.013	0.015	0.009

END OF WORK PACKAGE

**DIRECT SUPPORT MAINTENANCE
CAUSEWAY FERRY
BLOWER DRIVE ASSEMBLY
REMOVAL AND INSTALLATION**

INITIAL SETUP:**Tools**

Tool Kit, General Mechanic's (Item 130, WP 0188 00)
Wrench, Torque (150-750 in. lbs) (Item 142, WP 0188 00)
Wrench Set, Socket (3/8 in. sqdr.) (Item 135, WP 0188 00)
Screwdriver Attachment Set, Socket Wrench (Item 112, WP 0188 00)

Materials/Parts

Gasket
(72582)
NSN 5330-01-058-0585
PN 5148810

Personnel Required

Engineer 88L

References

TM 55-1945-205-10-1

Equipment Condition

SINCGARS Antenna Removed. (TM 11-5820-890-10-8)
Main Navigation Mast Removed. (TM 55-1945-205-24-1-1)
Intake Plenum Or Operators Cab Removed. (TM 55-1945-205-24-1-1)
Powered Section Engine Hatch Removed. (TM 55-1945-205-24-1-1)
Engine Cool To Touch.
Cylinder Head Poppet Valve Rocker Arm Covers Removed. (WP 0048 00)
Crankcase Breather Limiter Assembly Removed. (WP 0106 00)
Air Inlet Collector Assembly Removed. (WP 0104 00)
Fuel Pump Removed. (WP 0094 00)
Air Intake Housing Removed. (WP 0103 00)
Electronic Governor Rod Removed. (WP 0097 00)
Electronic Governor Actuator Removed. (WP 0098 00)
Blower Drive Shaft Removed. (WP 0109 00)
Blower Removed. (WP 0110 00)

REMOVE THE BLOWER DRIVE ASSEMBLY

1. Remove two socket head screws (1) and lock washers (2) from pipe (3).

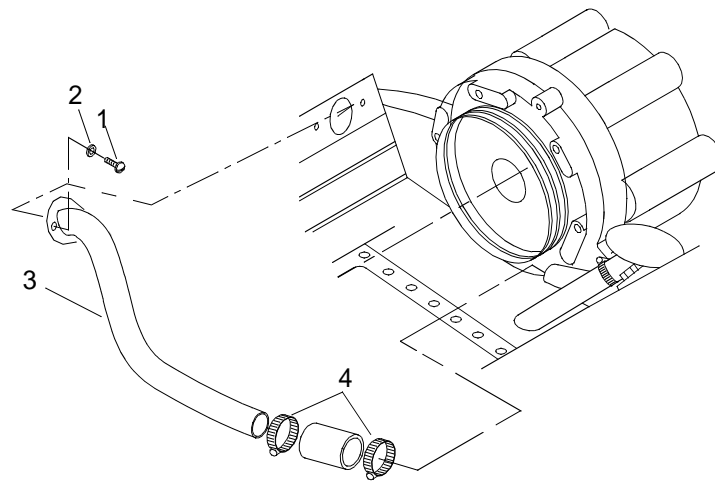

2. Remove two hose clamps (4) from hose (5).
3. Remove pipe (3) and hose (5) as an assembly.
4. Remove three bolts (6) and washers (7) from flywheel housing (8).

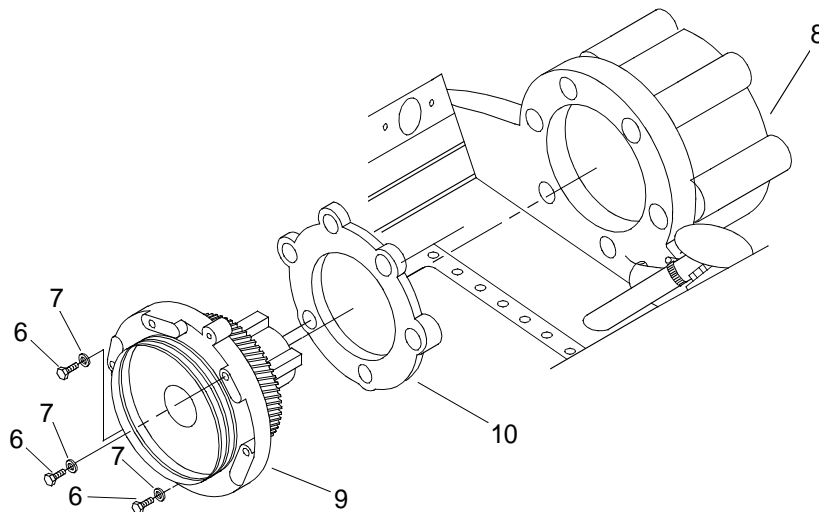

5. Remove blower drive (9) and gasket (10) from blower drive assembly. Discard gasket.

INSTALL BLOWER DRIVE ASSEMBLY

1. Install new gasket (10) and blower drive (9) on flywheel housing (8).
2. Install three bolts (6) and copper washers (7) in blower drive (9).
3. Using a torque wrench, torque bolts (6) to 300-360 in. lbs (34-41 N-m).
4. Verify the backlash is within 0.002 to 0.008 in. (0.00508 to 0.02032 cm) for new parts and 0.010 in. (0.0254 cm) for original parts.
5. If backlash is out of tolerance, replace blower drive gear (WP 0113 00) or camshaft timing gears (WP 0064 00).

-
6. Install new hose (5) on new pipe (3).
 7. Install pipe (3) and hose (5) as an assembly.
 8. Install two hose clamps (4) on hose (5).
 9. Install two socket head screws (1) and lock washers (2) on pipe (3).
 10. Install the blower. (WP 0110 00)
 11. Install electronic governor actuator. (WP 0098 00)
 12. Install electronic governor rod. (WP 0097 00)
 13. Install air intake housing. (WP 0103 00)
 14. Install fuel pump. (WP 0094 00)
 15. Install cylinder head poppet valve rocker arm covers. (WP 0048 00)
 16. Install air inlet collector assembly. (WP 0104 00)
 17. Install crankcase breather limiter assembly. (WP 0106 00)
 18. Install engine hatch. (TM 55-1945-205-24-1-1)
 19. Install intake plenum or operators cab. (TM 55-1945-205-24-1-1)
 20. Install main navigation mast. (TM 55-1945-205-24-1-1)
 21. Install SINGARS antenna. (TM 11-5820-890-10-8)
 22. Perform operational check of diesel engine. (TM 55-1945-205-10-1)

END OF WORK PACKAGE

**DIRECT SUPPORT MAINTENANCE
CAUSEWAY FERRY
BLOWER DRIVE ASSEMBLY
REPAIR**

INITIAL SETUP:**Tools**

Tool Kit, General Mechanic's (Item 130, WP 0188 00)
 Caps, Vice Jaw (Item 24, WP 0188 00)
 Apron, Utility (Item 8, WP 0188 00)
 Gloves, Chemical (Item 52, WP 0188 00)
 Goggles, Industrial (Item 54, WP 0188 00)
 Caliper Set, Micrometer, Outside (Item 22, WP 0188 00)
 Caliper Set, Micrometer, Inside (Item 23, WP 0188 00)
 Press, Arbor, Hand Operated (Item 97, WP 0188 00)
 Wrench, Torque (0-175 ft lbs) (Item 138, WP 0188 00)
 Wrench, Torque (150-750 in. lbs) (Item 142, WP 0188 00)
 Wrench Set, Socket (3/8 in. sqdr.) (Item 135, WP 0188 00)

Materials/Parts

Cleaner (Item 8, WP 0187 00)
 Grease, Automotive and Artillery (Item 20, WP 0187 00)
 Oil, Lubricating, Engine, 10W (Item 25, WP 0187 00)

Personnel Required

Engineer 88L

DISASSEMBLE BLOWER DRIVE ASSEMBLY

1. Remove three screws (1) and accessory drive hub (2) from blower drive assembly (3).

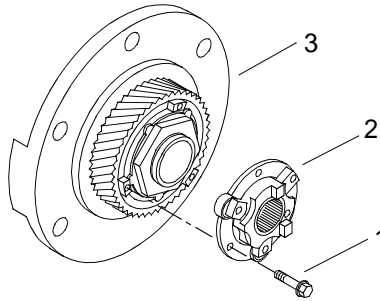

2. Remove three screws (4) and two spring plates (5) from auxiliary drive hub (6).

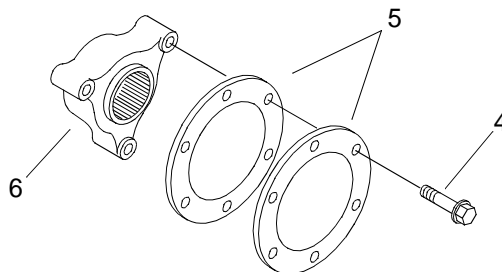

3. Mount blower drive support (7) in a vice equipped with soft jaw vice caps.

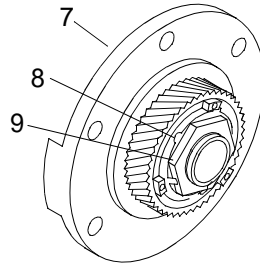

4. Bend the tabs of the tab lock washer (8) away from nut (9).
5. Remove nut (9) and tab lock washer (8) from blower drive support (7).
6. Remove thrust washer (10) and thrust bearing (11) from blower drive support (7).

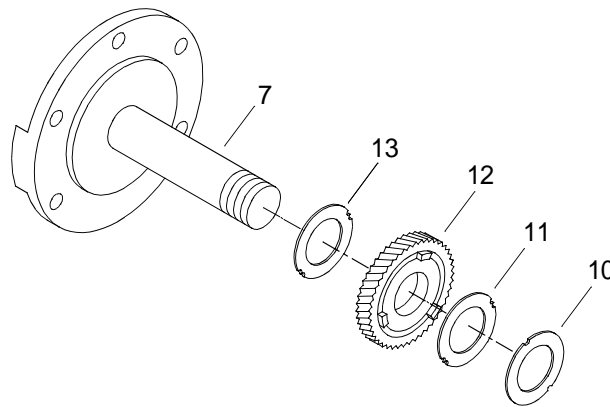

7. Remove drive gear (12) and second thrust bearing (13) from drive support (7).

NOTE

If the difference of measurements recorded in Step 8 and Step 9 is greater than 0.005 in. use an arbor press for bushing removal.

8. Using a micrometer, measure the outside diameter of the shaft (7) and record measurement.
9. Using an inside micrometer, measure the inside diameter of bushings (14) and record measurement.

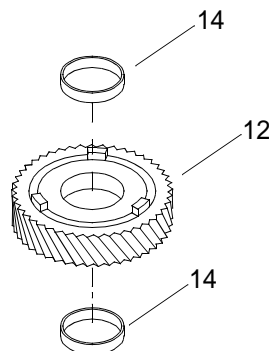

10. Using arbor press, press bushings (14) out of gear (12).

CLEAN THE BLOWER DRIVE ASSEMBLY**WARNING****CHEMICAL****EYE PROTECTION**

1. Clean all metal parts with cleaner.

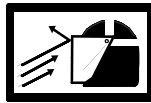
WARNING**FLYING PARTICLES**

2. Dry all parts with compressed air.

INSPECT BLOWER DRIVE ASSEMBLY

1. Inspect all parts for cracks, damaged threads or excessive wear. Replace damaged parts.
2. Using an outside micrometer, measure thrust washer (10) for a minimum thickness of 0.2350 in. (0.5969 cm) and a maximum thickness of 0.2450 in. (0.6223 cm) Replace damaged parts.
3. Using an outside micrometer, measure thrust bearing (11) for minimum thickness of 0.0590 in.(0.14986 cm) and a maximum measurement must not exceed 0.0610 in. (0.15494 cm) Replace damaged parts.
4. Using an inside micrometer, measure the bore of the support bushing (14) for a minimum measurement not to exceed 1.6260 in. (4.13004 cm) and a maximum measurement not to exceed 1.6265 in. (4.13131 cm) Record the diameter. Replace damaged parts.
5. Using a micrometer, measure the base of the support shaft (7).
6. Verify the measurements are between 1.6240 in. (4.12496 cm) and 1.6250 in. (4.1275 cm) Record the diameter.
7. Subtract step 4 from step 6.
 - a. If the parts are new, the allowable tolerance is 0.0010 (0.00254 cm) to 0.0025 in. (0.00635 cm).
 - b. If the old parts are to be re-used, the allowable tolerance is up to 0.0050 in. (0.0127 cm).
8. Inspect drive teeth for scoring, pitting or evidence of overheating. Replace damaged parts.
9. Inspect both flex spring plates for damage or distortion. Replace damaged parts.

ASSEMBLE THE BLOWER DRIVE ASSEMBLY

1. Using an arbor press, press bushings (14) into gear (12) until they are flush.
2. Place blower drive support (7) into the soft jaw vice caps of the vice.

3. Install drive gear (12) and second thrust bearing (13) on drive support (7).
4. Install thrust washer (10) and thrust bearing (11) on blower drive support (7).
5. Install tab lock washer (8) and nut (9) on blower drive support (7).
6. Using a torque wrench, torque nut (9) to 50 to 60 ft lbs (68 to 81 N-m).
7. Measure the clearance between thrust washer (10) and thrust bearing (11).
8. Verify tolerance is between 0.0050 in. (0.0127 cm) and 0.010 in. (0.00254 cm).
9. Bend the tabs of the tab lock washer (8) against the nut (9).
10. Install three screws (4) and two spring plates (5) on auxiliary drive hub (6).
11. Using a torque wrench, torque screws (4) to 420 to 480 in. lbs (47 to 54 N-m).
12. Install three screws (1) and accessory drive hub (2) on blower drive assembly (3).
13. Using a torque wrench, torque screws (1) to 420 to 480 in. lbs (47 to 54 N-m).

END OF WORK PACKAGE

**DIRECT SUPPORT MAINTENANCE
CAUSEWAY FERRY
TURBOCHARGER
REPLACEMENT**

INITIAL SETUP:**Tools**

Tool Kit, General Mechanic's (Item 130, WP 0188 00)
 Pan, Drain (Item 87, WP 0188 00)
 Apron, Utility (Item 8, WP 0188 00)
 Gloves, Chemical (Item 52, WP 0188 00)
 Goggles, Industrial (Item 54, WP 0188 00)
 Respirator, Air Filtering (Item 109, WP 0188 00)

Materials/Parts

Turbocharger Assembly
 (72582)
 PN 23503908
 Gasket
 (72582)
 NSN 5330-01-037-4129
 PN 8929529
 Gasket
 (72582)
 NSN 5330-00-725-2388
 PN 5170468
 Spill Clean-Up Kit, Hazardous Material (Item 32, WP 0187 00)

Personnel Required

Engineer 88L

References

TM 55-1945-205-10-1

Equipment Condition

SINGARS Antenna Removed. (TM 11-5820-890-10-8)
 Main Navigation Mast Removed. (TM 55-1945-205-24-1-1)
 Operators Cab Removed. (TM 55-1945-205-24-1-1)
 Intake Plenum Removed. (TM 55-1945-205-24-1-1)
 Engine Hatch Removed. (TM 55-1945-205-24-1-1)
 Engine Cool To Touch.
 Crankcase Breather Limiter Assembly Removed. (WP 0106 00)
 Air Inlet Collector Assembly Removed. (WP 0104 00)
 Air Intake Housing Removed. (WP 0103 00)
 Fresh Water Cooling System Drained. (WP 0134 00)

REMOVE TURBOCHARGER**NOTE**

This task is typical for both port and starboard turbochargers on the port and starboard powered modules

1. Loosen clamps (1).

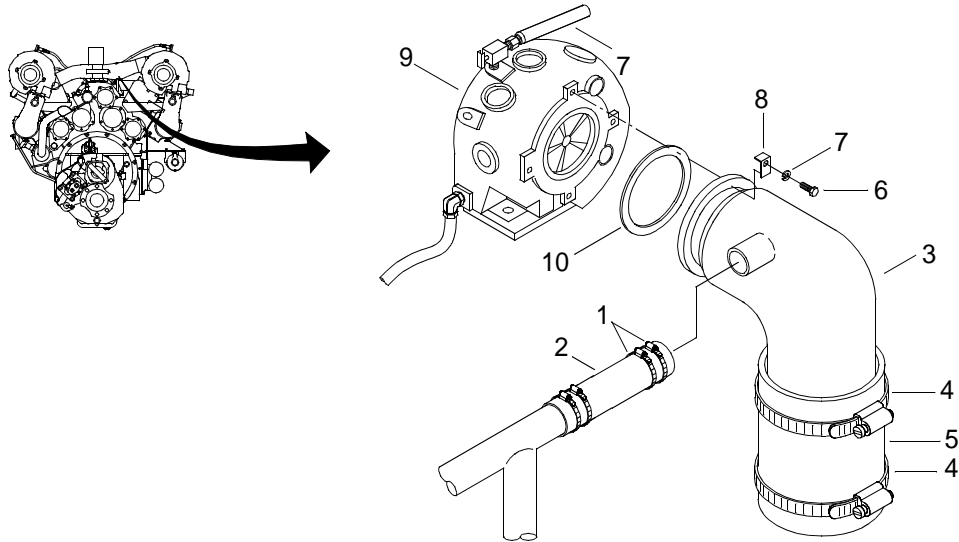

2. Disconnect hose (2) from the side of the exhaust elbow (3).
3. Loosen clamps (4).
4. Disconnect hose (5) from the exhaust elbow (3).
5. Remove four cap screws (6), washers (7) and clamps (8) securing the exhaust elbow (3) to the turbocharger (9).
6. Remove exhaust elbow (3).
7. Remove gasket (10) from turbocharger (9).
8. Position drain pan beneath turbocharger (9).

WARNING



CHEMICAL



EYE PROTECTION



VAPOR

9. Remove the coolant lines (11 and 12) and pet cock (13) from turbocharger (9).

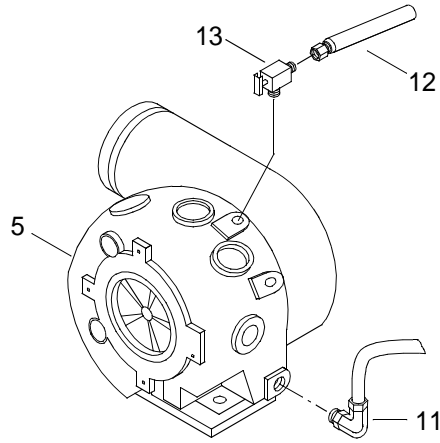

WARNING



CHEMICAL

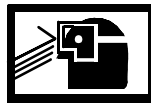

EYE PROTECTION

10. Remove the oil inlet hose (14) from bushing (15).

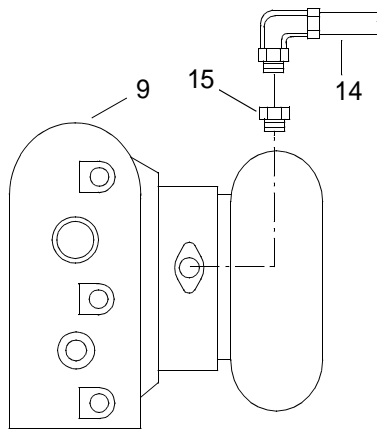

11. Remove bushing (15) from turbocharger (9).

12. Remove hex head bolts (16), lock washers (17) securing oil drain hose (18) to turbocharger (9).

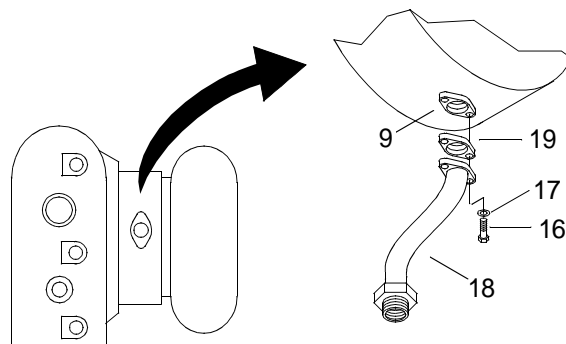

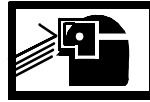
WARNING**CHEMICAL****EYE PROTECTION**

13. Remove oil drain hose (18) from turbocharger (9).
14. Remove gasket (19) from turbocharger (9) and discard.
15. Remove four hex nuts (20) and lock washers (21) from studs (22) on the exhaust flange (23).

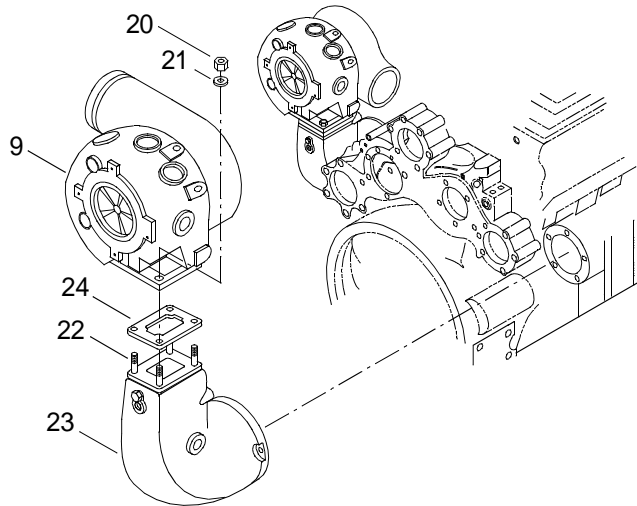
**WARNING****HEAVY OBJECTS**

16. Remove turbocharger (9) from exhaust flange (23).
17. Remove gasket (24) from exhaust flange (23) and discard.

WARNING**CHEMICAL****EYE PROTECTION****VAPOR**

18. Remove drain pan and dispose of contents in accordance with local procedures.

INSTALL TURBOCHARGER

1. Install gasket (24) on exhaust flange (23).

WARNING**HEAVY OBJECTS**

2. Position turbocharger (9) on exhaust flange (23).
3. Install four hex nuts (20) and lock washers (21) on studs (22) on the exhaust flange (23).
4. Install gasket (19) of turbocharger (9).

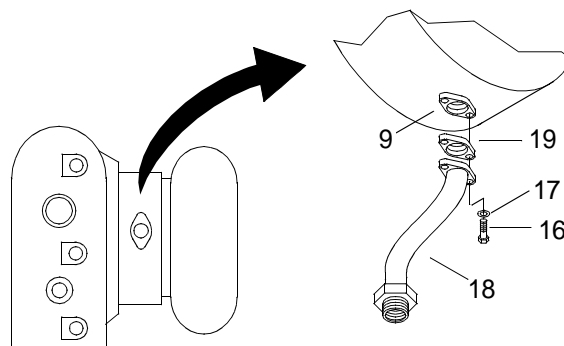
**WARNING****CHEMICAL****EYE PROTECTION**

5. Install oil drain hose (18) on the bottom of turbocharger (9).
6. Install two hex head bolts (16) and lock washers (17) securing oil drain hose (18) to the bottom of the turbocharger (9).

7. Install bushing (15) on turbocharger (9).

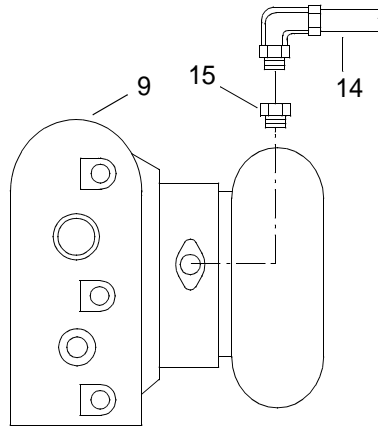

WARNING



CHEMICAL



EYE PROTECTION

8. Install the oil inlet hose (14) on bushing (15).

WARNING



CHEMICAL



EYE PROTECTION



VAPOR

9. Install the coolant line (11) on turbocharger (9).

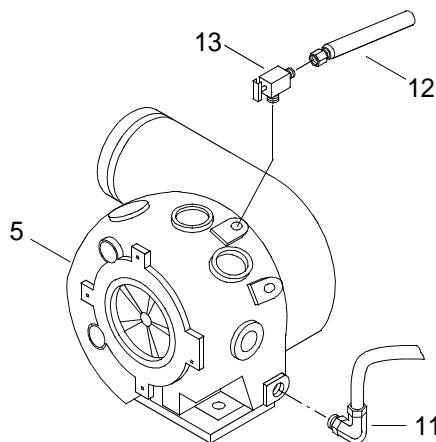

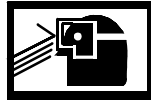
WARNING**CHEMICAL****EYE PROTECTION****VAPOR**

10. Install the coolant line (12) and pet cock (13) on turbocharger (9).
11. Install gasket (10) on turbocharger (9).

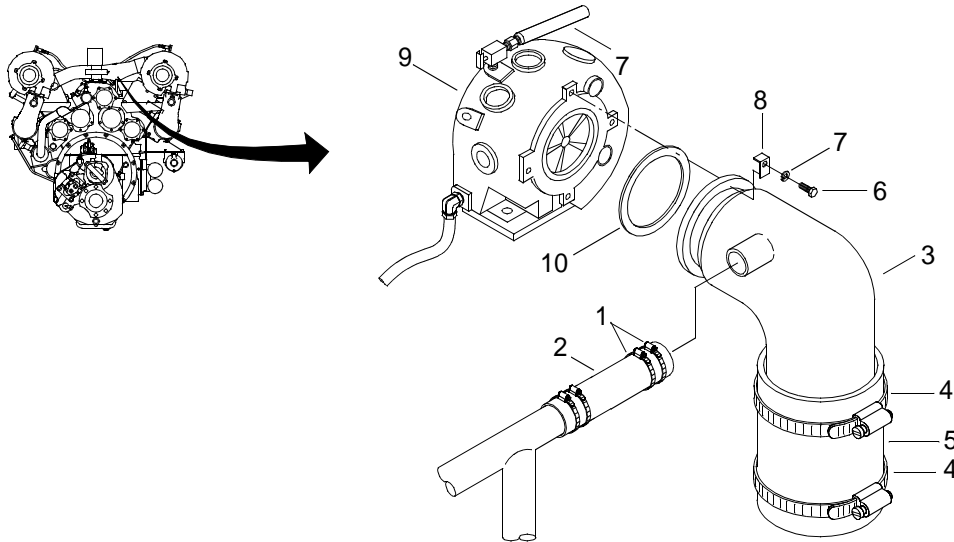

12. Install the exhaust elbow (3) on turbocharger (9).
13. Install four cap screw (6), washers (7) and clamps (8) securing the exhaust elbow (3) to the turbocharger (9).
14. Connect the hose (5) on the exhaust elbow (3).
15. Install two clamps (4) on hose (5).
16. Tighten clamps (4).
17. Install the hose (2) on the side of the exhaust elbow (3).
18. Install two clamps (1) on hose (2).
19. Tighten clamps (1).
20. Install air intake housing. (WP 0103 00)
21. Install air inlet collector assembly. (WP 0104 00)
22. Install crankcase breather limiter assembly. (WP 0106 00)
23. Service fresh water cooling system. (WP 0133 00)
24. Install engine hatch. (TM 55-1945-205-24-1-1)

25. Install operators cab. (TM 55-1945-205-24-1-1)
26. Install intake plenum. (TM 55-1945-205-24-1-1)
27. Install main navigation mast. (TM 55-1945-205-24-1-1)
28. Install SINCGARS antenna. (TM 11-5820-890-10-8)
29. Perform operational check of diesel engine. (TM 55-1945-205-10-1)

WARNING

**CHEMICAL****EYE PROTECTION****VAPOR****SLICK FLOOR**

30. Clean up spilled fluid with spill kit and dispose of spill kit waste in accordance with local procedures.

END OF WORK PACKAGE

**UNIT LEVEL MAINTENANCE
CAUSEWAY FERRY
LUBE OIL SYSTEM CRANKCASE
SERVICING**

INITIAL SETUP:**Tools**

Tool Kit, General Mechanic's (Rail and Marine) (Item 131, WP 0188 00)
 Gloves, Chemical (Item 52, WP 0188 00)
 Goggles, Industrial (Item 54, WP 0188 00)
 Pan, Drain (Item 87, WP 0188 00)
 Evacuation Unit, FLOCS (Item 36, WP 0188 00)

Materials/Parts

Oil, Lubricating, Engine, 40W (Item 27, WP 0187 00)
 Qty 32
 Spill Clean-Up Kit, Hazardous Material (Item 32, WP 0187 00)

Personnel Required

Engineer 88L

References

TM 55-1945-205-10-1

Equipment Condition

Engine Cool To Touch.

DRAIN LUBE OIL SYSTEM CRANKCASE**NOTE**

This task is typical for port and starboard engines.

1. Verify MAIN circuit breaker (1) on the propulsion module circuit breaker panel A6 is off.

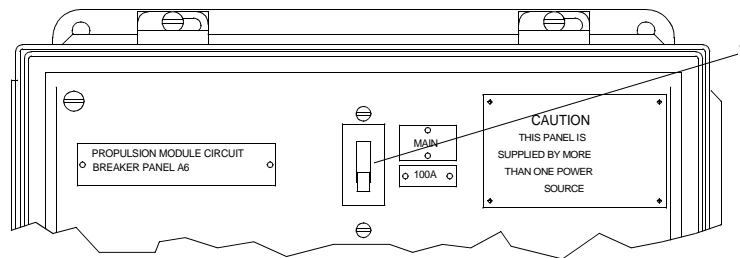

2. Position fast lube system evacuation unit sufficiently close to Fast Lube Oil Change System (FLOCS) to reach it with evacuation unit's hose.

- Remove dust cap (2) from coupling half (3).

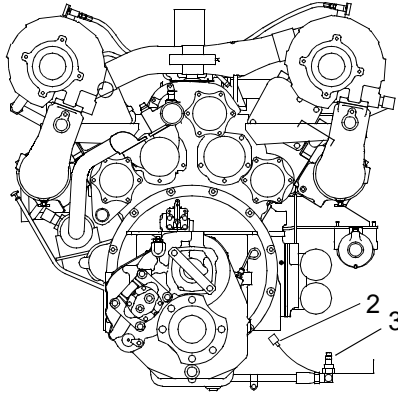

- Position drain pan below coupling half (3).
- Connect coupling half (3) to matching coupling half of FLOCS.
- Evacuate oil from crankcase using FLOCS.
- Disconnect coupling half (3) of evacuation unit from matching coupling half of FLOCS.
- Replace dust cap (2) on coupling half (3).

FILL LUBE OIL SYSTEM CRANKCASE

WARNING



CHEMICAL



EYE PROTECTION

- Fill diesel engine with 32 quarts of oil (with filter changed) through the lube oil fill port (4).

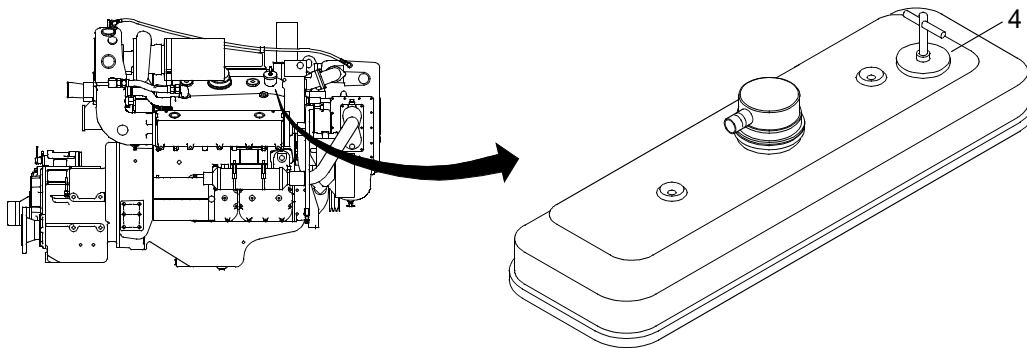

2. Check oil level on the dipstick (5). Adjust oil level as required.

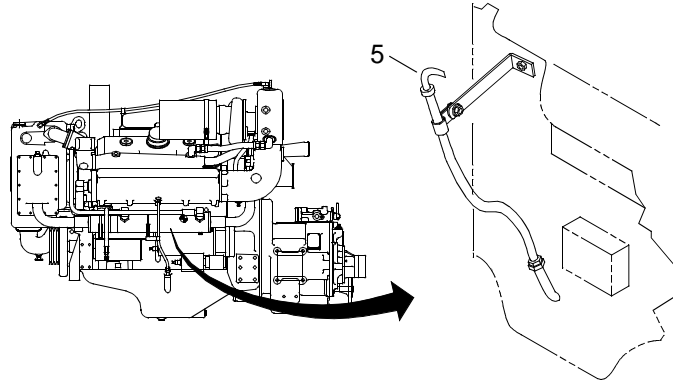
**WARNING****CHEMICAL****EYE PROTECTION**

3. Remove drain pan and dispose of contents in accordance with local procedures.

WARNING**CHEMICAL****EYE PROTECTION**

4. Clean up spilled fluid with a spill kit and dispose of spill kit waste in accordance with local procedures.
5. Perform operational checks. (TM 55-1945-205-10-1)

END OF WORK PACKAGE

**UNIT LEVEL MAINTENANCE
CAUSEWAY FERRY
LUBE OIL SYSTEM CRANKCASE
PRESSURE TESTING**

INITIAL SETUP:**Test Equipment**

Manometer, Vertical Tube (Item 82, WP 0188 00)

Tools

Tool Kit, General Mechanic's (Rail and Marine) (Item 131, WP 0188 00)

Gloves, Chemical (Item 52, WP 0188 00)

Goggles, Industrial (Item 54, WP 0188 00)

Personnel Required

Engineer 88L

References

TM 55-1945-205-10-1

TEST CRANKCASE PRESSURE**NOTE**

This task is typical for both the port and starboard engines.

1. Verify MAIN circuit breaker (1) on propulsion module circuit breaker panel A6 is off.

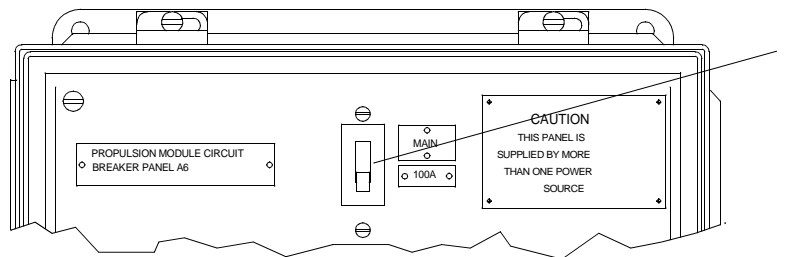

2. Remove the oil level dipstick (2) from the engine dipstick tube (3).

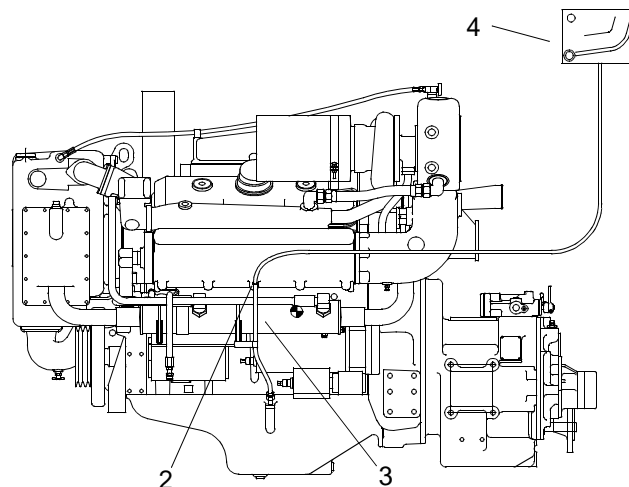

WARNING

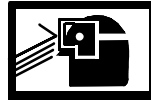
**CHEMICAL****EYE PROTECTION****NOTE**

To ensure a valid reading is obtained, the manometer must not be below the level of the oil.

3. Connect the manometer (4) to the dipstick tube opening (2).
4. Start the engine and bring the engine speed to 1800 RPM. (TM 55-1945-205-10-1)
5. Verify that the reading on the manometer (4) indicates 3.1 in. water maximum.
6. Shut down the engine. (TM 55-1945-205-10-1)

WARNING

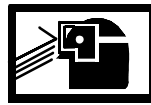
**CHEMICAL****EYE PROTECTION**

7. Disconnect the manometer (4).

WARNING

**CHEMICAL****EYE PROTECTION**

8. Install the engine oil dipstick (2) in engine dipstick tube (3).

END OF WORK PACKAGE

**UNIT LEVEL MAINTENANCE
CAUSEWAY FERRY
LUBE OIL SYSTEM TURBOCHARGER FLANGED OIL TUBE TO
ENGINE OIL HOSE
REPLACEMENT**

INITIAL SETUP:**Tools**

Tool Kit, General Mechanic's (Rail and Marine) (Item 130, WP 0188 00)
Gloves, Chemical (Item 52, WP 0188 00)
Goggles, Industrial (Item 54, WP 0188 00)
Pan, Drain (Item 87, WP 0188 00)

Materials/Parts

Gasket
(72582)
NSN 5330-00-725-2388
PN 5170468
Tube Assembly
(72582)
PN 8924598
Tube Assembly
(72582)
PN 23501748
Antiseize Compound (Item 6, WP 0187 00)
Spill Clean-Up Kit, Hazardous Material (Item 32, WP 0187 00)

Personnel Required

Engineer 88L

References

TM 55-1945-205-10-1

Equipment Condition

Engine Cool To Touch.

REMOVE FLANGED OIL TUBE**NOTE**

This task is typical for both port and starboard flanged oil tubes on both port and starboard engines.

1. Verify MAIN circuit breaker (1) on propulsion module circuit breaker panel A6 is off.

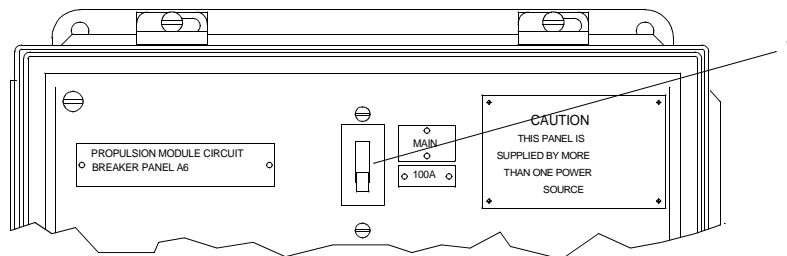

-
- Position drain pan under flanged oil tube (2).

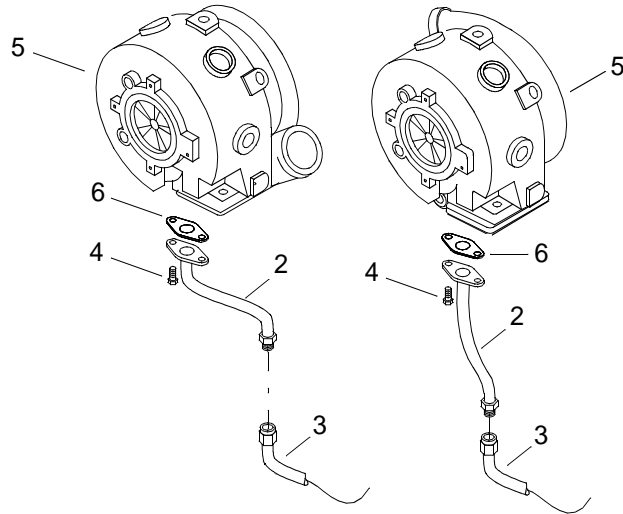

WARNING



CHEMICAL



EYE PROTECTION

- Disconnect hose (3) from flanged oil tube (2).
- Remove two cap screws (4) from flanged oil tube (2).

WARNING



CHEMICAL



EYE PROTECTION

- Remove flanged oil tube (2) from turbocharger (5) and discard.
- Remove gasket (6) from turbocharger (5) and discard.

WARNING



CHEMICAL



EYE PROTECTION

- Remove drain pan and dispose of contents in accordance with local procedures.

INSTALL FLANGED OIL TUBE

1. Install new gasket (6) on turbocharger (5).
2. Install new flanged oil tube (2) on turbocharger (5).
3. Install two cap screws (4) on flanged oil tube (2).
4. Tighten two cap screws (4).
5. Apply antiseize compound to threads of flanged oil tube (2).
6. Connect hose (3) on flanged oil tube (2).
7. Tighten oil hose (3).

WARNING

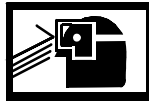
**CHEMICAL****EYE PROTECTION****SLICK FLOOR**

8. Clean up spilled fluid with spill kit and dispose of spill kit waste in accordance with local procedure.
9. Perform operational check of diesel engine. (TM 55-1945-205-10-1)

END OF WORK PACKAGE

**UNIT LEVEL MAINTENANCE
CAUSEWAY FERRY
LUBE OIL SYSTEM HOSES
REPLACEMENT**

INITIAL SETUP:**Tools**

Tool Kit, General Mechanic's (Rail and Marine) (Item 130, WP 0188 00)
Gloves, Chemical (Item 52, WP 0188 00)
Goggles, Industrial (Item 54, WP 0188 00)
Pan, Drain (Item 87, WP 0188 00)

Materials/Parts

Spill Clean-Up Kit, Hazardous Material (Item 32, WP 0187 00)

Personnel Required

Engineer 88L

References

TM 55-1945-205-10-1

Equipment Condition

Engine Cool To Touch.

REMOVE OIL HOSES**NOTE**

This task is typical for all oil hoses.

1. Place a drain pan under the work area.
2. Using a wrench, hold the elbow or fitting (1).

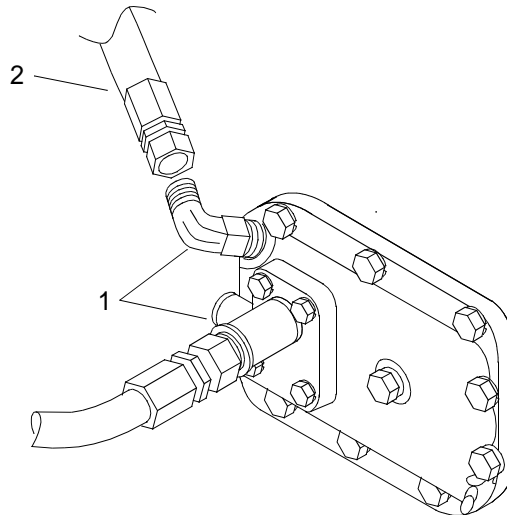

WARNING

**CHEMICAL****EYE PROTECTION**

3. Using another wrench, remove the oil hose (2) from the elbow or fitting (1).
4. Repeat steps 1 thru 3 for the other end of the oil hose (2).
5. Remove any clamps securing the oil hose (2) to the equipment.
6. Remove and discard the oil hose (2).

WARNING

**CHEMICAL****EYE PROTECTION**

7. Remove drain pan and dispose of its contents in accordance with local procedure.

INSTALL OIL HOSES

1. Install the new oil hose (2).
2. Secure the oil hose (2) to equipment with any clamps previously removed.
3. Using a wrench, hold the elbow or fitting (1).
4. Using another wrench, tighten the oil hose (2) on elbow or fitting (1).
5. Repeat steps 3 and 4 for the other end of the oil hose (2).

WARNING

**CHEMICAL****EYE PROTECTION****SLICK FLOOR**

6. Clean up spilled fluid with spill kit and dispose of spill kit waste in accordance with local procedure.
7. Perform operational check of diesel engine. (TM 55-1945-205-10-1)

END OF WORK PACKAGE

**GENERAL SUPPORT MAINTENANCE
CAUSEWAY FERRY
LUBE OIL PUMP
REMOVAL AND INSTALLATION**

INITIAL SETUP:**Tools**

Tool Kit, General Mechanic's (Item 130, WP 0188 00)
Expander, Oil Seal (Item 37, WP 0188 00)
Handle Driver (Item 62, WP 0188 00)
Guide Studs Set (Item 58, WP 0188 00)
Wrench, Torque (0-175 ft lbs) (Item 138, WP 0188 00)
Wrench, Torque (150-750 in. lbs) (Item 142, WP 0188 00)
Wrench Set, Socket (Item 135, WP 0188 00)
Goggles, Industrial (Item 54, WP 0188 00)
Gloves, Chemical (Item 52, WP 0188 00)
Pan, Drain (Item 87, WP 0188 00)
Mallet, Rubber (Item 81, WP 0188 00)

Materials/Parts

Gasket
(72582)
PN 5121714
Lubricating Oil, Engine (Item 25, WP 0187 00)
Spill Clean-up Kit, Hazardous Material (Item 32 WP 0187 00)

Personnel Required

Engineer 88L

Equipment Condition

Crankcase Breather Limiter Assembly Removed. (WP 0106 00)
Air Inlet Collector Assembly Removed. (WP 0104 00)
Turbochargers Removed. (WP 0114 00)
Exhaust Manifolds Removed. (WP 0163 00)
Marine Gear Oil Cooler Removed. (TM 55-1945-205-24-1-3)
Fuel Cooler Removed. (WP 0081 00)
Air Box Covers Removed. (WP 0035 00)
Air Box Drains Removed. (WP 0036 00)
Starter Motor Removed. (WP 0170 00)
Lube Oil Dipstick Tube Assembly Removed. (WP 0130 00)
Overspeed Governor Removed. (WP 0175 00)
Marine Gear Oil Cooler Mounting Bracket Removed. (WP 0164 00)
Lube Oil Cooler Removed. (WP 0128 00)
Engine Mounted On Stand. (WP 0032 00)
Lube Oil Pan Removed. (WP 0127 00)
Lube Oil Distribution System Removed. (WP 0122 00)

REMOVE LUBE OIL PUMP ASSEMBLY

NOTE

This task is typical for both port and starboard engines.

After removal of the cap screws from the oil pump assembly it may be necessary to strike the sides of the oil pump assembly with a rubber mallet to free it from the crankshaft assembly.

1. Position drain pan under oil pump (1).

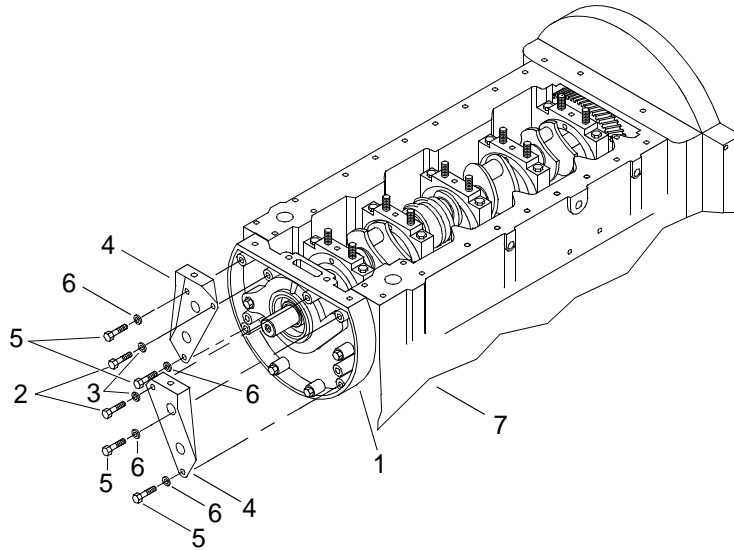

2. Remove two cap screws (2) and lock washers (3) from engine mount brackets (4).
3. Remove four cap screws (5) and lock washers (6) securing engine mount brackets (4) and oil pump (1) to engine block (7).
4. Remove brackets (4) from oil pump (1).

5. Remove four remaining cap screws (8 and 9) and lock washers (10 and 11) securing oil pump assembly (1) to engine block (7).

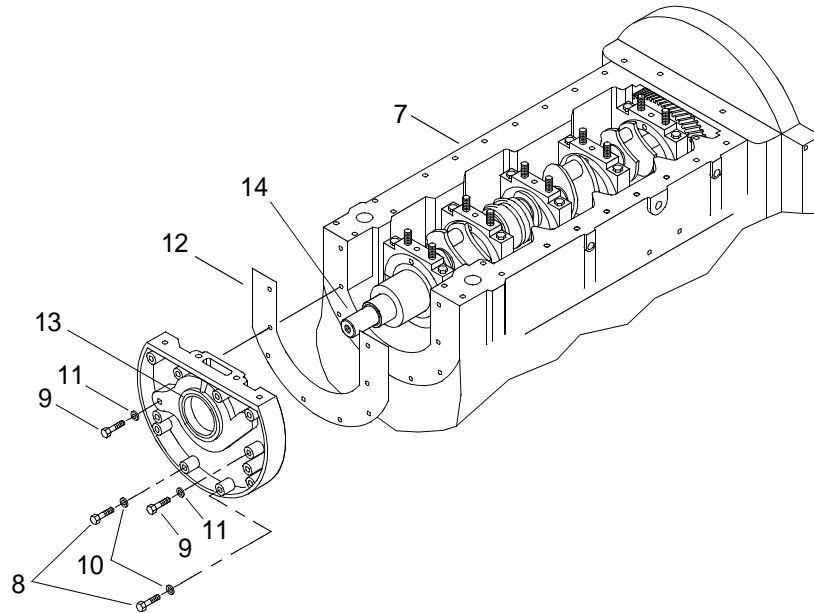

WARNING



CHEMICAL

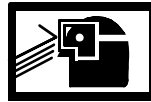

EYE PROTECTION

6. Remove oil pump assembly (1) from engine block (7).

WARNING



CHEMICAL



EYE PROTECTION

7. Remove oil pump gasket (12) from engine block (7) and discard.

WARNING



CHEMICAL



EYE PROTECTION

8. Remove drain pan and dispose of its contents in accordance with local procedures.

INSTALL LUBE OIL PUMP ASSEMBLY

1. Install new gasket (12) on engine block (7).

WARNING

**CHEMICAL****EYE PROTECTION**

CAUTION

Failure to properly lubricate the parts and tools in the following procedure may result in oil seal lip damage.

2. Apply engine oil to the oil seal expander, oil seal (13) and crankshaft (14) to assist the oil seal assembly installation.

WARNING

**CHEMICAL****EYE PROTECTION**

3. Using the oil seal expander with guide studs, install the oil pump (1).
 - a. Position oil pump (1) on engine block (7) over crankshaft (14).
 - b. Install four cap screws (8 and 9) and washers (2) securing oil pump assembly (1) to on engine block (7) over crankshaft assembly (14).
4. Using a torque wrench, torque top two cap screws (8) to 300-360 in. lbs (34-41 N m).
5. Using a torque wrench, torque two cap screws (9) to 80-90 ft lbs (108-122 N m).

6. Position brackets (4) on oil pump (1).

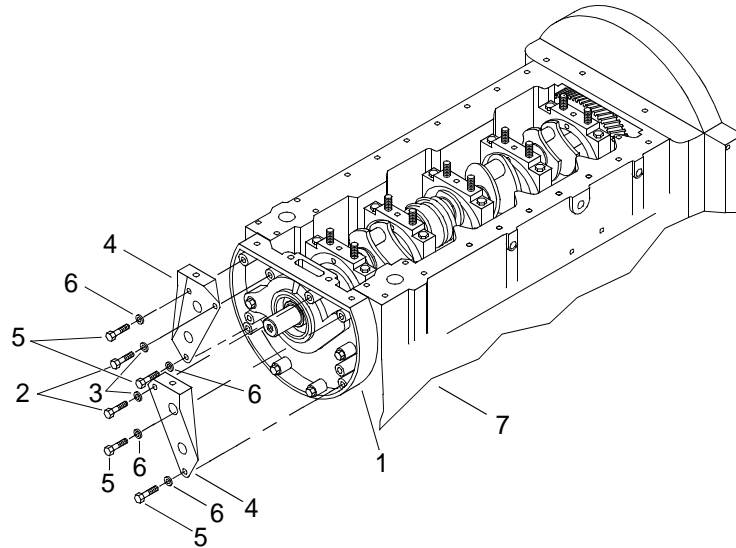

7. Install four cap screw (5) and lock washers (6) securing brackets (4) and oil pump (1) to engine block (7).
8. Install cap screws (2) and lock washers (3) securing brackets (4) to oil pump (1).
9. Using a torque wrench, torque four cap screws (5) to 80-90 ft lbs (108-122 N m).
10. Using a torque wrench, torque top two cap screws (2) to 300-360 in. lb (34-41 N m).
11. Install lube oil distribution system. (WP 0122 00)
12. Install lube oil pan. (WP 0127 00)
13. Remove engine from stand. (WP 0032 00)
14. Install lube oil dipstick tube assembly. (WP 0130 00)
15. Install lube oil cooler. (WP 0128 00)
16. Install marine gear oil cooler mounting bracket. (WP 0164 00)
17. Install overspeed governor. (WP 0175 00)
18. Install starter motor. (WP 0170 00)
19. Install air box drains. (WP 0036 00)
20. Install air box covers. (WP 0035 00)
21. Install fuel cooler. (WP 0081 00)
22. Install marine gear oil cooler. (TM 55-1945-205-24-1-3)
23. Install exhaust manifolds. (WP 0163 00)
24. Install turbochargers. (WP 0114 00)

25. Install air inlet collector assembly. (WP 0104 00)

26. Install crankcase breather limiter assembly. (WP 0106 00)

WARNING



CHEMICAL



EYE PROTECTION



SLICK FLOOR

27. Clean up spilled fluid with a spill kit and dispose of spill kit waste in accordance with local procedures.

END OF WORK PACKAGE

**GENERAL SUPPORT MAINTENANCE
CAUSEWAY FERRY
LUBE OIL PUMP
REPAIR**

INITIAL SETUP:**Tools**

Tool Kit, General Mechanic's (Item 130, WP 0188 00)
 Apron, Utility (Item 8, WP 0188 00)
 Goggles, Industrial (Item 54 WP 0188 00)
 Gauge, Cylinder (Item 42, WP 0188 00)
 Gloves, Chemical (Item 52, WP 0188 00)
 Wrench, Torque (150-750 in. lbs) (Item 142, WP 0188 00)
 Wrench Set, Socket (3/8 in. sqdr.) (Item 135, WP 0188 00)
 Caliper Set, Micrometer, Outside (Item 22, WP 0188 00)
 Caliper, Micrometer, Inside (Item 23, WP 0188 00)

Materials/Parts

Cleaning Compound, Powdered (Item 10, WP 0187 00)
 Lubricating Oil, Engine (Item 26, WP 0187 00)

Personnel Required

Engineer 88L

DISASSEMBLE LUBE OIL PUMP

WARNING



CHEMICAL



EYE PROTECTION

1. Remove eight self-locking bolts (1) securing the oil pump gear retaining plate (2) to the crankshaft front cover (3).

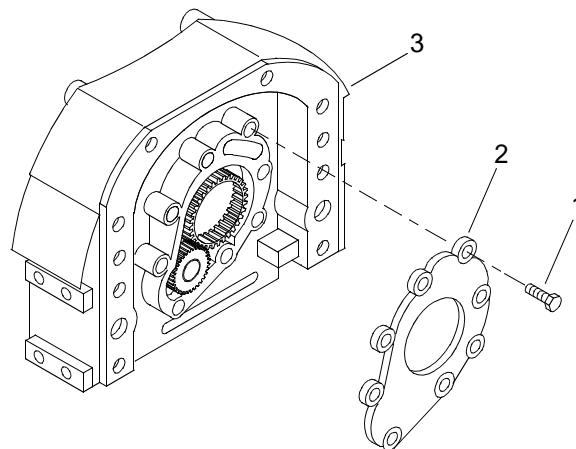

2. Remove retaining plate (2).
3. Remove oil pump driven gear (4) and hub (5).

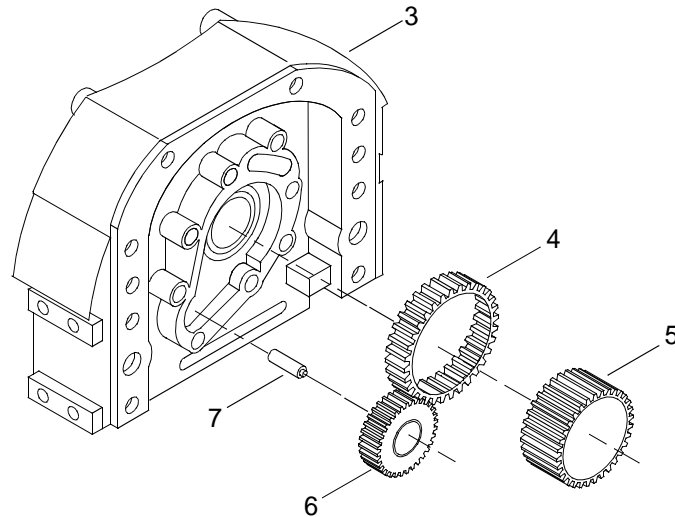

- Remove driven gear (6) and shaft (7).

CLEAN LUBE OIL PUMP

WARNING



CHEMICAL



EYE PROTECTION

- Clean all metal parts with cleaning compound.

WARNING



EYE PROTECTION

NOTE

While using compressed air do not exceed 40 PSI (276 kPa). Failure to follow this procedure will result in injury to personnel.

- Dry parts with compressed air.

INSPECT LUBE OIL PUMP

NOTE

Two different tolerances are given when replacing the driven gear and shaft. If new parts are used the clearance between the driven gear bushing and the shaft is .001 inches - .0025 inches. If used parts are being used the maximum clearance is .0035 inches.

- Check the driven gear shaft (7) for damage. Replace damaged parts.

2. Install the driven gear shaft (7) into the crankshaft cover (3).
3. Using a depth gauge, verify the shoulder on the shaft is flush to .020 in. below the finished face of the crankshaft cover.
4. Remove the shaft (7) after the inspection/verification has been completed.
5. Inspect driven gear and bushing (6) and shaft (7).
 - a. Using a micrometer, verify the clearance between the used driven gear bushing (6) and shaft (7) is within tolerance of 0.001-0.0035 in.
 - b. Using a micrometer, measure the diameter of the shaft (7).
 - c. Using an inside micrometer, measure the inside diameter of the driven gear bushing (6).
 - d. Subtract the measurement obtained in step f from the measurement in step g to obtain the clearance specified in step e. Replace damaged parts.
6. Inspect new driven gear and bushing (6) is to be used.
 - a. Verify the clearance between the new driven gear and bushing and shaft is within tolerance of 0.001-0.0025 in.
 - b. Using a micrometer, measure the diameter of the shaft.
 - c. Using an inside micrometer, measure the inside diameter of the driven gear and bushing (6).
 - d. Subtract the measurement obtained in step b from the measurement in step c to obtain the clearance specified in Step a.
7. Inspect the inner face of the retaining plate (2) for damage, wear or scoring. Replace damaged parts.

ASSEMBLE LUBE OIL PUMP

WARNING

**CHEMICAL****EYE PROTECTION**

1. Apply a light coat of lubricating oil to the pump gears and driven gear.

2. Install the shaft (7) into the front cover (3).

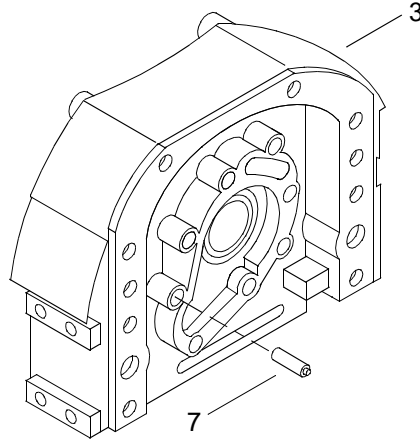

3. Install the drive gear (4), hub (5) and driven gear (6) into the front cover (3).

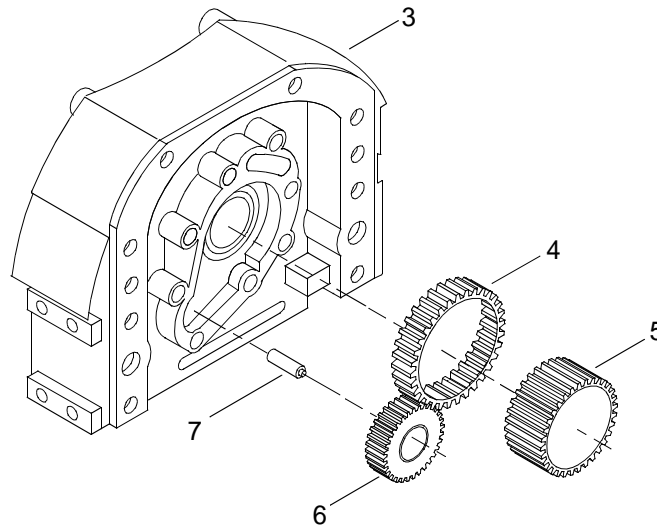

4. Install the retaining plate (2) over the gears and on the front cover (3).

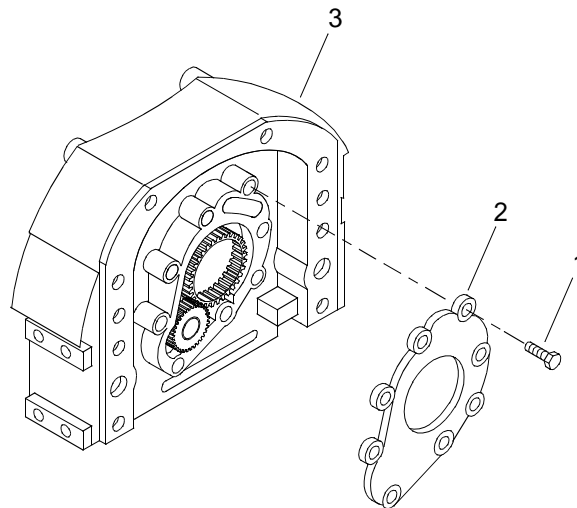

NOTE

During the following procedure self-locking bolts must be used due to the close proximity of the oil pump and crankshaft.

5. Install eight bolts (1) into retaining plate (2).
6. Using torque wrench, torque bolts (1) to 156-204 in. lbs (18-23 N-m).

END OF WORK PACKAGE

**GENERAL SUPPORT MAINTENANCE
CAUSEWAY FERRY
LUBE OIL PUMP INLET SCREEN
REMOVAL, CLEANING, INSPECTION AND INSTALLATION**

INITIAL SETUP:**Tools**

Tool Kit, General Mechanic's (Item 130, WP 0188 00)
Goggles Industrial (Item 54, WP 0188 00)
Gloves, Chemical (Item 52, WP 0188 00)

Materials/Parts

Cleaner (Item 8 WP 0187 00)
Cloth, Cleaning (Item 13 WP 0187 00)

Personnel Required

Engineer 88L

Equipment Condition

Crankcase Breather Limiter Assembly Removed. (WP 0106 00)
Air Inlet Collector Assembly Removed. (WP 0104 00)
Turbochargers Removed. (WP 0114 00)
Exhaust Manifolds Removed.(WP 0163 00)
Marine Gear Oil Cooler Removed.(TM 55-1945-205-24-1-3)
Fuel Cooler Removed.(WP 0081 00)
Air Box Covers Removed. (WP 0035 00)
Air Box Drains Removed. (WP 0036 00)
Starter Motor Removed. (WP 0170 00)
Lube Oil Dipstick Tube Assembly Removed. (WP 0130 00)
Overspeed Governor Removed. (WP 0175 00)
Marine Gear Oil Cooler Mounting Bracket Removed. (WP 0164 00)
Lube Oil Cooler Removed. (WP 0128 00)
Engine Mounted On Stand. (WP 0032 00)
Lube Oil Pan Removed. (WP 0127 00)

REMOVE LUBE OIL PUMP INLET SCREEN

WARNING

**CHEMICAL****EYE PROTECTION**

1. While holding nut (1) and washer (2), remove bolt (3), washer (4) and spacer (5) from screen (6).

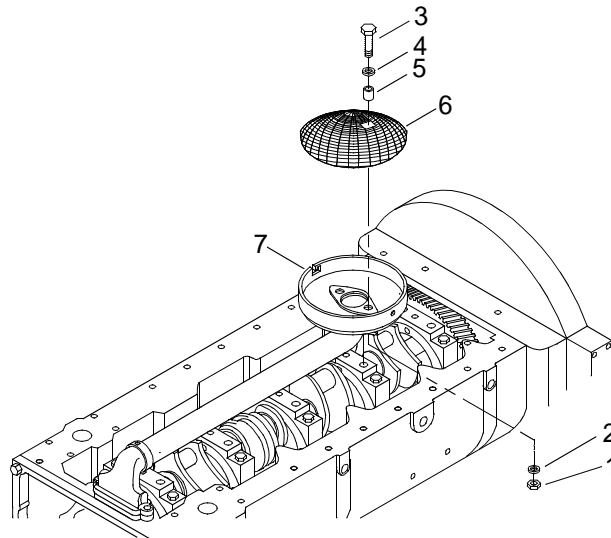

WARNING



CHEMICAL



EYE PROTECTION

- Remove screen (6) from cover (7).

CLEAN LUBE OIL PUMP INLET SCREEN

WARNING



CHEMICAL



EYE PROTECTION

- Using cleaner and cleaning cloth, clean nut (1), washer (2), bolt (3), washer (4), spacer (5) and screen (6).

WARNING



CHEMICAL



EYE PROTECTION

Do not exceed 40 PSI (276 kPa) compressed air pressure. Failure to comply could result in serious injury to personnel.

- Using compressed air, dry all parts.

INSPECT LUBE OIL PUMP INLET SCREEN

1. Inspect screen (6) for cracks, distortion, holes, tears, deterioration and rust. Replace as necessary.
2. Inspect cover (7) for cracks, distortion, holes, tears, deterioration and rust. Replace as necessary.

INSTALL LUBE OIL PUMP INLET SCREEN

1. Install screen (6) into cover (7).
2. Install spacer (5), washer (4) and bolt (3) into screen (6).
3. Install washer (2) and nut (1) on bolt (3).
4. Tighten bolt (3).
5. Install lube oil pan. (WP 0127 00)
6. Remove engine from stand. (WP 0032 00)
7. Install lube oil dipstick tube assembly. (WP 0130 00)
8. Install lube oil cooler. (WP 0128 00)
9. Install marine gear oil cooler mounting bracket. (WP 0164 00)
10. Install overspeed governor. (WP 0175 00)
11. Install starter motor. (WP 0170 00)
12. Install air box drains. (WP 0036 00)
13. Install air box covers. (WP 0035 00)
14. Install fuel cooler. (WP 0081 00)
15. Install marine gear oil cooler. (TM 55-1945-205-24-1-3)
16. Install exhaust manifolds. (WP 0163 00)
17. Install turbochargers. (WP 0114 00)
18. Install air inlet collector assembly. (WP 0104 00)
19. Install crankcase breather limiter assembly. (WP 0106 00)

END OF WORK PACKAGE

**GENERAL SUPPORT MAINTENANCE
CAUSEWAY FERRY
LUBE OIL SYSTEM DISTRIBUTION COMPONENTS
REMOVAL, CLEANING, INSPECTION AND INSTALLATION**

INITIAL SETUP:**Tools**

Tool Kit, General Mechanic's (Item 130, WP 0188 00)
 Wrench, Torque (150-750 in. lbs) (Item 142, WP 0188 00)
 Wrench Set, Socket (3/8 in. sqdr.) (Item 135, WP 0188 00)
 Gloves, Chemical (Item 52, WP 0188 00)
 Goggles, Industrial (Item 54, WP 0188 00)

Materials/Parts

Gasket
 PN 5167380
 Gasket
 PN 5117242
 Hose Assembly
 PN CAHP0083
 Hose Assembly
 PN 23506665
 Cleaner (Item 8, WP 0187 00)

Personnel Required

Engineer 88L

Equipment Condition

Crankcase Breather Limiter Assembly Removed. (WP 0106 00)
 Air Inlet Collector Assembly Removed. (WP 0104 00)
 Turbochargers Removed. (WP 0114 00)
 Exhaust Manifolds Removed. (WP 0163 00)
 Marine Gear Oil Cooler Removed. (TM 55-1945-205-24-1-3)
 Fuel Cooler Removed. (WP 0081 00)
 Air Box Covers Removed. (WP 0035 00)
 Air Box Drains Removed. (WP 0036 00)
 Starter Motor Removed. (WP 0170 00)
 Lube Oil Dipstick Tube Assembly Removed. (WP 0130 00)
 Overspeed Governor Removed. (WP 0175 00)
 Marine Gear Oil Cooler Mounting Bracket Removed. (WP 0164 00)
 Lube Oil Cooler Removed. (WP 0128 00)
 Engine Mounted On Stand. (WP 0032 00)
 Lube Oil Pan Removed. (WP 0127 00)

REMOVE OIL DISTRIBUTION SYSTEM COMPONENTS

WARNING

**CHEMICAL****EYE PROTECTION**

1. Remove oil pump screen (1) from tube assembly (2).

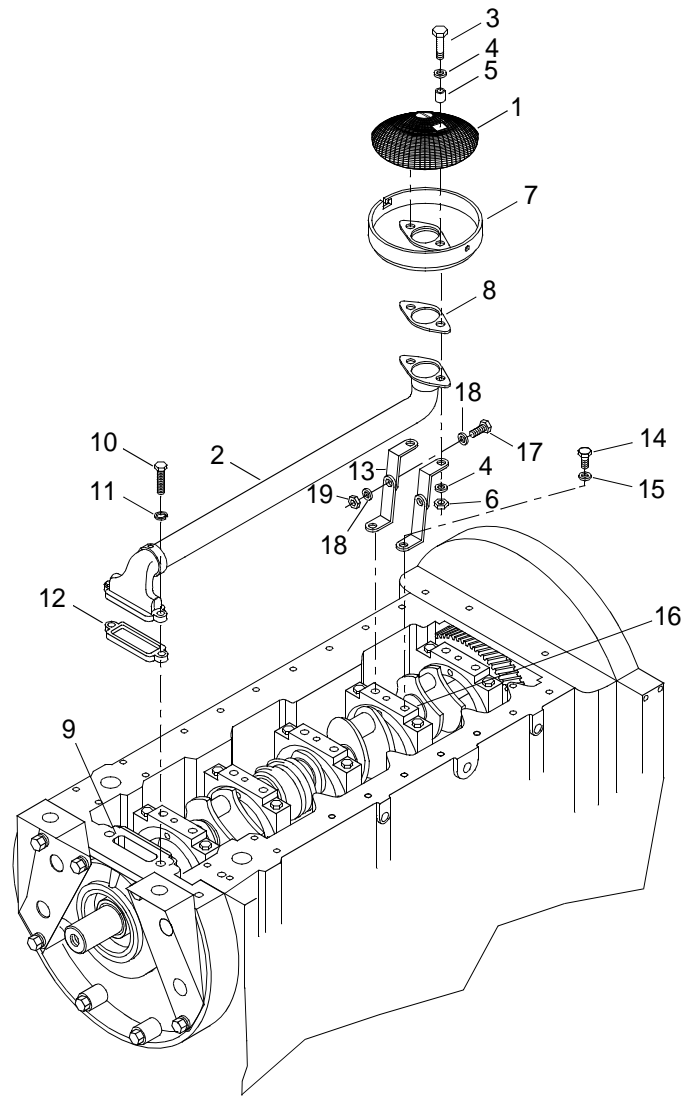

- a. Remove two bolts (3), four washers (4), two spacers (5) and two nuts (6) that secure oil pump screen (1), cover (7) and gasket (8) to tube assembly (2).
- b. Remove oil pump screen (1), cover (7) and discard gasket (8).
2. Remove tube assembly (2) from oil pump housing (9).
 - a. Remove two bolts (10) and two lock washers (11) that secure tube assembly (2) to oil pump housing (9).
 - b. Remove tube assembly (2).
 - c. Remove and discard gasket (12).
3. Remove two support brackets (13).
 - a. Remove two bolts (14) and two washers (15) securing two support brackets (13) to main bearing cap (16).
 - b. Separate the two legs of each support bracket (13) by removing one bolt (17), two washers (18) and one nut (19) from slotted hole.

CLEAN OIL DISTRIBUTION SYSTEM COMPONENTS

WARNING

**CHEMICAL****EYE PROTECTION**

1. Using cleaner and a clean cloth, clean screen (1) of dirt, grease oil and other foreign matter.

WARNING

**CHEMICAL****EYE PROTECTION**

2. Using cleaner and a clean cloth, clean all hoses, fittings, nuts, bolts and tube assembly (2).

INSPECT OIL DISTRIBUTION SYSTEM COMPONENTS

1. Inspect screen (1) for broken, missing, or damaged screening. Replace as necessary.
2. Inspect tube assembly (2) for dents, cracks and foreign objects that are obstructing the tube. Replace tube as necessary.

INSTALL OIL DISTRIBUTION SYSTEM COMPONENTS

1. Install two support brackets (13).
 - a. Connect two legs of each support bracket (13) by installing one bolt (17), two washers (18) and one nut (19) in slotted hole.
 - b. Attach two support brackets (13) to main bearing cap (16) with two bolts (14) and two washers (15).
2. Attach tube assembly (2) to oil pump housing (9).
 - a. Place new gasket (12) on oil pump housing (9).
 - b. Place forward end of tube assembly (2) over gasket (12) and opposite end of support brackets (13).
 - c. Secure tube assembly (2) to oil pump housing (9) with two bolts (10) and two lock washers (11).
 - d. Using torque wrench, torque bolts (10) to 360-420 in. lbs (41-47 N-m).

3. Install oil pump screen (1) on tube assembly (2).
 - a. Place new gasket (8), cover (7) and oil pump screen (1) over flanged end of tube assembly (2).
 - b. Attach oil pump screen (1), cover (7) and new gasket (8) to tube assembly (2) with two bolts (3), four washers (4), two spacers (5) and two nuts (6).
 - c. Using torque wrench, torque bolts (3) to 156-204 in. lbs (18-23 N-m).
4. Install lube oil pan. (WP 0127 00)
5. Remove engine from stand. (WP 0032 00)
6. Install lube oil cooler. (WP 0128 00)
7. Install marine gear oil cooler mounting bracket. (WP 0164 00)
8. Install overspeed governor. (WP 0175 00)
9. Install lube oil dipstick tube assembly. (WP 0130 00)
10. Install starter motor. (WP 0170 00)
11. Install air box drains. (WP 0036 00)
12. Install air box covers. (WP 0035 00)
13. Install fuel cooler. (WP 0081 00)
14. Install marine gear oil cooler. (TM 55-1945-205-24-1-3)
15. Install exhaust manifolds. (WP 0163 00)
16. Install turbochargers. (WP 0114 00)
17. Install air inlet collector assembly. (WP 0104 00)
18. Install crankcase breather limiter assembly. (WP 0106 00)

END OF WORK PACKAGE

**GENERAL SUPPORT MAINTENANCE
CAUSEWAY FERRY
LUBE OIL PRESSURE REGULATOR VALVE
REMOVAL AND INSTALLATION**

INITIAL SETUP:**Tools**

Tool Kit, General Mechanic's (Item 130, WP 0188 00)
Wrench, Torque (150-750 in. lbs) (Item 142, WP 0188 00)
Wrench Set, Socket (3/8 in. sqdr.) (Item 135, WP 0188 00)

Materials/Parts

Gasket
PN 5117269

Personnel Required

Engineer 88L

Equipment Condition

Crankcase Breather Limiter Assembly Removed. (WP 0106 00)
Air Inlet Collector Assembly Removed. (WP 0104 00)
Turbochargers Removed. (WP 0114 00)
Exhaust Manifolds Removed. (WP 0163 00)
Marine Gear Oil Cooler Removed. (TM 55-1945-205-24-1-3)
Fuel Cooler Removed. (WP 0081 00)
Air Box Covers Removed. (WP 0035 00)
Air Box Drains Removed. (WP 0036 00)
Starter Motor Removed. (WP 0170 00)
Lube Oil Dipstick Tube Assembly Removed. (WP 0130 00)
Overspeed Governor Removed. (WP 0175 00)
Marine Gear Oil Cooler Mounting Bracket Removed. (WP 0164 00)
Lube Oil Cooler Removed. (WP 0128 00)
Engine Mounted On Stand. (WP 0032 00)
Lube Oil Pan Removed. (WP 0127 00)

REMOVE LUBE OIL PRESSURE REGULATOR VALVE

1. Remove two bolts (1) and lock washers (2) from lube oil pressure regulator valve (3).

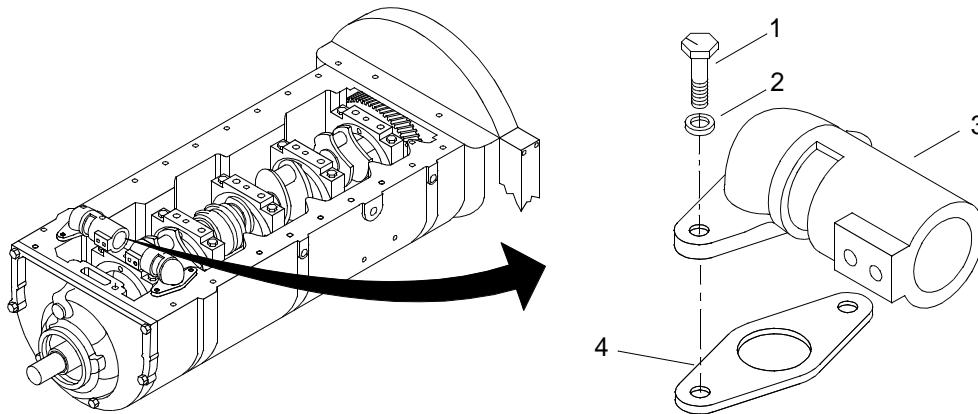

2. Remove lube oil pressure regulator valve (3).

3. Remove gasket (4) and discard.

INSTALL LUBE OIL PRESSURE REGULATOR VALVE

1. Install new gasket (4).
2. Install lube oil pressure regulator valve (3).
3. Install two lock washers (2) and bolts (1) in lube oil pressure regulator valve (3).
4. Using a torque wrench, torque bolts (1) to 30-35 ft lbs (40-48 Nm).
5. Install lube oil pan. (WP 0127 00)
6. Remove engine from stand. (WP 0032 00)
7. Install marine gear oil cooler mounting bracket. (WP 0164 00)
8. Install overspeed governor (WP 0175 00)
9. Install lube oil cooler. (WP 0128 00)
10. Install lube oil dipstick tube assembly. (WP 0130 00)
11. Install starter motor. (WP 0170 00)
12. Install air box drains. (WP 0036 00)
13. Install air box covers. (WP 0035 00)
14. Install fuel cooler. (WP 0081 00)
15. Install marine gear oil cooler. (TM 55-1945-205-24-1-3)
16. Install exhaust manifolds. (WP 0163 00)
17. Install turbochargers. (WP 0114 00)
18. Install air inlet collector assembly. (WP 0104 00)
19. Install crankcase breather limiter assembly. (WP 0106 00)

END OF WORK PACKAGE

**GENERAL SUPPORT MAINTENANCE
CAUSEWAY FERRY
LUBE OIL PRESSURE REGULATOR VALVE
REPAIR**

INITIAL SETUP:**Tools**

Tool Kit, General Mechanic's (Item 130, WP 0188 00)
Caps, Vise Jaw (Item 24, WP 0188 00)
Apron, Utility (Item 8, WP 0188 00)
Goggles, Industrial (Item 54, WP 0188 00)
Gloves, Chemical (Item 52, WP 0188 00)

Materials/Parts

Cleaning Compound, Powered (Item 10, WP 0187 00)
Lubricating Oil, Engine (Item 25, WP 0187 00)

Personnel Required

Engineer 88L

DISASSEMBLE LUBE OIL PRESSURE REGULATOR VALVE

1. Secure the lube oil pressure regulator valve body (1) in vise (2) with soft jaws (3).

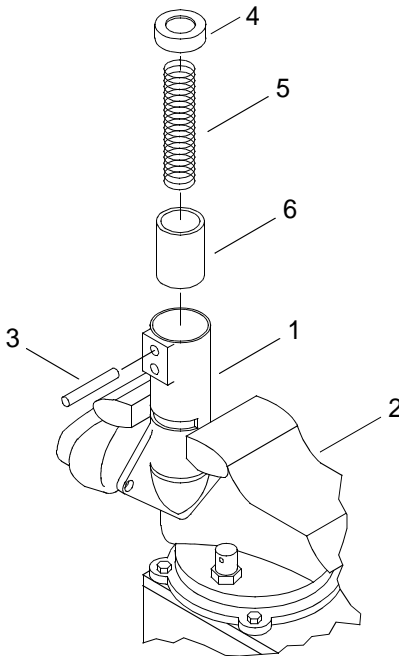

WARNING



EYE PROTECTION

**Spring is under compression load. Keep spring compressed when removing pin.
Failure to comply could result in serious injury to personnel.**

2. Using hammer and drift punch, drive spring seat retaining pin (3) out of lube oil pressure regulator valve body (1).
3. Remove spring seat (4), spring (5) and valve (6) from lube oil pressure regulator valve body (1).

WARNING

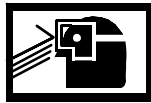

EYE PROTECTION

4. Remove lube oil pressure regulator valve body (1) from vise (2).

CLEAN LUBE OIL PRESSURE REGULATOR VALVE

WARNING



CHEMICAL

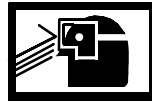

EYE PROTECTION

1. Using cleaning compound, clean lube oil pressure regulator valve (6).

WARNING



EYE PROTECTION

**Do not exceed 40 PSI (276 kPa) compressed air pressure. Failure to comply could
result in serious injury to personnel.**

2. Using compressed air, dry lube oil pressure regulator valve (6).

INSPECT LUBE OIL PRESSURE REGULATOR VALVE

1. Inspect lube oil pressure regulator valve body (1) for nicks, dents, cracks and deformation. Replace defective part.
2. Inspect for free movement of lube oil regulator valve (6), inside regulator body. Replace defective part.

3. Inspect lube oil pressure regulator body (1) for clogged condition. Remove item causing clogged condition.
4. Inspect spring (5) for deformation, pitting, breaks or corrosion. Replace defective part.
5. Inspect spring seat (4) for deformation. Replace defective part.
6. Inspect spring seat retaining pin (3) for corrosion or deformation. Replace defective part.

ASSEMBLE LUBE OIL PRESSURE REGULATOR VALVE

1. Secure lube oil pressure regulator valve body (1) in vise (2).

WARNING



CHEMICAL

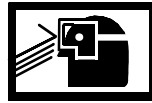

EYE PROTECTION

2. Using lubricating oil, lubricate lube oil regulator valve (6).
3. Insert lube oil pressure regulator valve (6) into lube oil pressure regulator valve body (1) closed end first.
4. Install spring (5) into lube oil pressure regulator valve body (1).
5. Install spring seat (4), open end first, into lube oil pressure regulator valve body (1).

WARNING

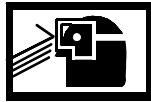

EYE PROTECTION

6. While compressing spring seat (4) install spring seat retaining pin (3) into oil pressure regulator valve body (1).

END OF WORK PACKAGE

**GENERAL SUPPORT MAINTENANCE
CAUSEWAY FERRY
LUBE OIL PRESSURE RELIEF VALVE
REMOVAL AND INSTALLATION**

INITIAL SETUP:**Tools**

Tool Kit, General Mechanic's (Item 130, WP 0188 00)
Wrench, Torque (150-750 in. lbs) (Item 142, WP 0188 00)
Wrench Set, Socket (3/8 in. sqdr.) (Item 135, WP 0188 00)

Materials/Parts

Gasket
(72582)
NSN 5330-00-735-4291
PN 5117269

Personnel Required

Engineer 88L

Equipment Condition

Crankcase Breather Limiter Assembly Removed. (WP 0106 00)
Air Inlet Collector Assembly Removed. (WP 0104 00)
Turbochargers Removed. (WP 0114 00)
Exhaust Manifolds Removed.(WP 0163 00)
Marine Gear Oil Cooler Removed.(TM 55-1945-205-24-1-3)
Fuel Cooler Removed.(WP 0081 00)
Air Box Covers Removed. (WP 0035 00)
Air Box Drains Removed. (WP 0036 00)
Starter Motor Removed. (WP 0170 00)
Lube Oil Dipstick Tube Assembly Removed. (WP 0130 00)
Marine Gear Oil Cooler Mounting Bracket Removed. (WP 0164 00)
Overspeed Governor Removed. (WP 0175 00)
Lube Oil Cooler Removed. (WP 0128 00)
Engine Mounted On Stand. (WP 0032 00)
Oil Pan Removed. (WP 0127 00)

REMOVE LUBE OIL PRESSURE RELIEF VALVE

1. Remove two bolts (1) and lock washers (2) from lube oil pressure relief valve (3).

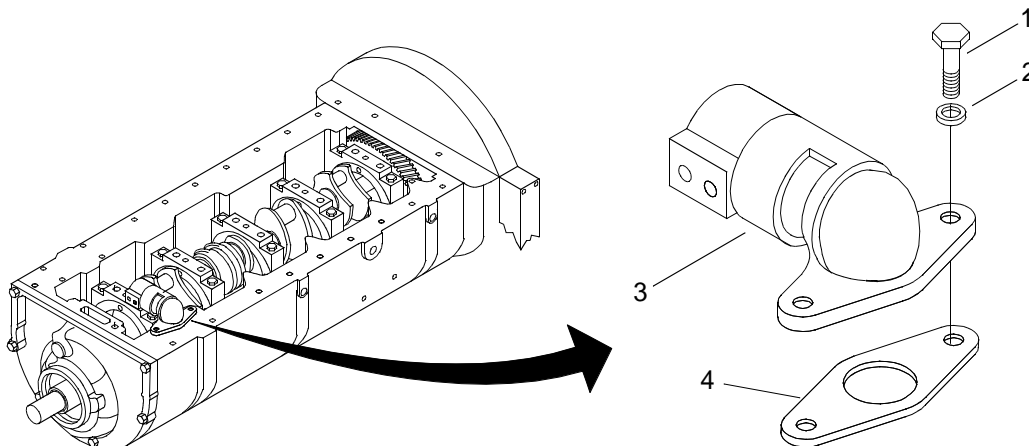

2. Remove lube oil pressure relief valve (3).
3. Remove gasket (4) and discard.

INSTALL LUBE OIL PRESSURE RELIEF VALVE

1. Install new gasket (4).
2. Install lube oil pressure relief valve (3).
3. Install two lock washers (2) and bolts (1) in lube oil pressure relief valve (3).
4. Using torque wrench and socket set, torque bolts (1) to 30 - 35 ft lbs (40.7 - 47.5 N-m).
5. Install oil pan. (WP 0127 00)
6. Remove engine from stand. (WP 0032 00)
7. Install lube oil cooler. (WP 0128 00)
8. Install lube oil dipstick tube assembly. (WP 0130 00)
9. Marine gear oil cooler mounting bracket. (WP 0164 00)
10. Overspeed governor removed. (WP 0175 00)
11. Install starter motor. (WP 0170 00)
12. Install air box drains. (WP 0036 00)
13. Install air box covers. (WP 0035 00)
14. Install fuel cooler. (WP 0081 00)
15. Install marine gear oil cooler. (TM 55-1945-205-24-1-3)
16. Install exhaust manifolds. (WP 0163 00)
17. Install turbochargers. (WP 0114 00)
18. Install air inlet collector assembly. (WP 0104 00)
19. Install crankcase breather limiter assembly. (WP 0106 00)

END OF WORK PACKAGE

**GENERAL SUPPORT MAINTENANCE
CAUSEWAY FERRY
LUBE OIL PRESSURE RELIEF VALVE
REPAIR**

INITIAL SETUP:**Tools**

Tool Kit, General Mechanic's (Item 130 WP 0188 00)
Caps, Vise Jaw (Item 24, WP 0188 00)
Apron, Utility (Item 8 WP 0188 00)
Goggles, Industrial (Item 54, WP 0188 00)
Gloves, Chemical (Item 52, WP 0188 00)

Materials/Parts

Cleaning Compound, Powdered (Item 10, WP 0187 00)
Lubricating Oil, Engine (Item 25, WP 0187 00)

Personnel Required

Engineer 88L

DISASSEMBLE LUBE OIL PRESSURE RELIEF VALVE

1. Secure the lube oil pressure relief valve body (1) in vise (2) with soft jaws.

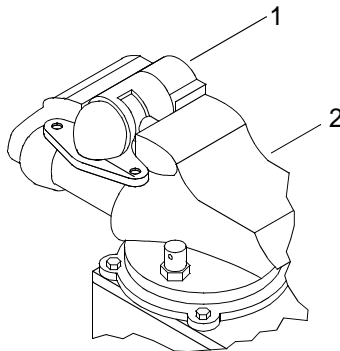

WARNING

**EYE PROTECTION**

**Spring is under compression load. Keep spring compressed when removing pin.
Failure to comply could result in serious injury to personnel.**

2. Using hammer and drift punch, drive spring seat retaining pin (3) out of lube oil pressure relief valve body (1).

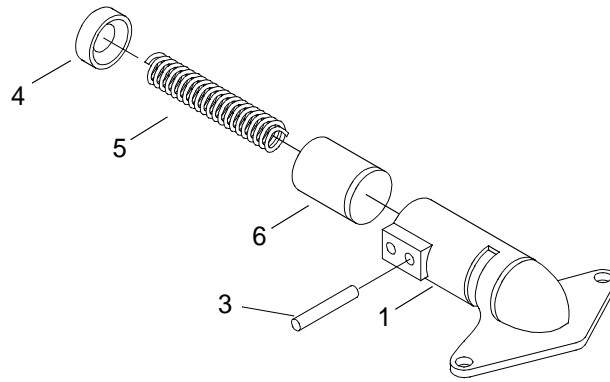

3. Remove spring seat (4), spring (5) and valve (6) from lube oil pressure relief valve body (1).
4. Remove lube oil pressure relief valve body (1) from vise (2).

CLEAN LUBE OIL PRESSURE RELIEF VALVE

WARNING



CHEMICAL



EYE PROTECTION

1. Using cleaning compound, clean lube oil pressure relief valve components.

WARNING

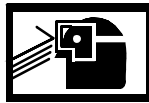

EYE PROTECTION

Do not exceed 40 PSI compressed air pressure. Failure to comply could result in serious injury to personnel.

2. Using compressed air, dry lube oil pressure relief valve components.

INSPECT LUBE OIL PRESSURE RELIEF VALVE

1. Inspect pressure relief valve body (1) for nicks, dents, cracks and distortion. Replace defective part.
2. Check that relief valve (6) moves freely inside of relief valve body (1). Replace defective part.
3. Inspect pressure relief valve body (1) for clogged condition. Replace defective part.
4. Inspect spring (5) for distortion, pitting, breaks or corrosion. Replace defective part.
5. Inspect spring seat (4) for distortion. Replace defective part.
6. Inspect spring seat retaining pin (3) for corrosion or distortion. Replace defective part.

ASSEMBLE LUBE OIL PRESSURE RELIEF VALVE

1. Secure lube oil pressure relief valve body (1) in vise (2).

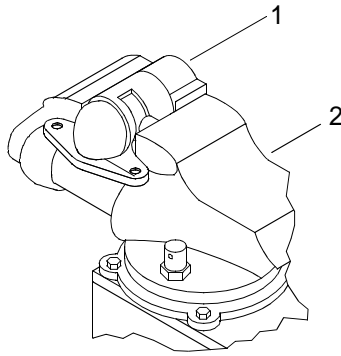

WARNING

**CHEMICAL****EYE PROTECTION**

2. Using lubricating oil, lubricate lube oil pressure relief valve (6).

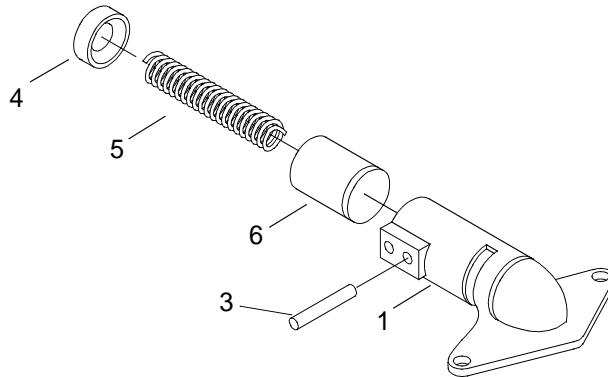

3. Insert lube oil pressure relief valve (6) into lube oil pressure relief valve body (1) closed end first.
4. Install spring (5) into lube oil pressure relief valve body (1).
5. Install spring seat (4), open end first, into lube oil pressure relief valve body (1).
6. Compress spring seat (4) and install spring seat retaining pin (3) into lube oil pressure relief valve body (1).

END OF WORK PACKAGE

**GENERAL SUPPORT MAINTENANCE
CAUSEWAY FERRY
LUBE OIL PAN
REPLACEMENT**

INITIAL SETUP:**Tools**

Tool Kit, General Mechanic's (Item 130, WP 0188 00)
Goggles, Industrial (Item 54, WP 0188 00)
Gloves, Chemical (Item 52, WP 0188 00)
Wrench, Torque (150-750 in. lbs) (Item 142, WP 0188 00)
Wrench Set, Socket (3/8 in. sqdr.) (Item 135, WP 0188 00)
Apron, Utility (Item 8, WP 0188 00)

Materials/Parts

Oil Pan
(72582)
NSN 2815-01-391-0256
PN 5147750
Oil Pan Gasket
(72582)
NSN 5330-00-902-8108
PN 5117231
Cleaner (Item 8, WP 0187 00)
Adhesive (Item 2, WP 0187 00)
Sealing Compound (Item 30, WP 0187 00)

Personnel Required

Engineer 88L

Equipment Condition

Crankcase Breather Limiter Assembly Removed. (WP 0106 00)
Air Inlet Collector Assembly Removed. (WP 0104 00)
Turbochargers Removed. (WP 0114 00)
Exhaust Manifolds Removed. (WP 0163 00)
Marine Gear Oil Cooler Removed. (TM 55-1945-205-24-1-3)
Fuel Cooler Removed. (WP 0081 00)
Air Box Covers Removed. (WP 0035 00)
Air Box Drains Removed. (WP 0036 00)
Starter Motor Removed. (WP 0170 00)
Lube Oil Dipstick Tube Assembly Removed. (WP 0130 00)
Overspeed Governor Removed. (WP 0175 00)
Marine Gear Oil Cooler Mounting Bracket Removed. (WP 0164 00)
Lube Oil Cooler Removed. (WP 0128 00)
Engine Mounted On Stand. (WP 0032 00)

REMOVE LUBE OIL PAN

1. With engine inverted on engine stand, remove 24 bolts (1) and lock washers (2) securing oil pan (3) to engine block (4).

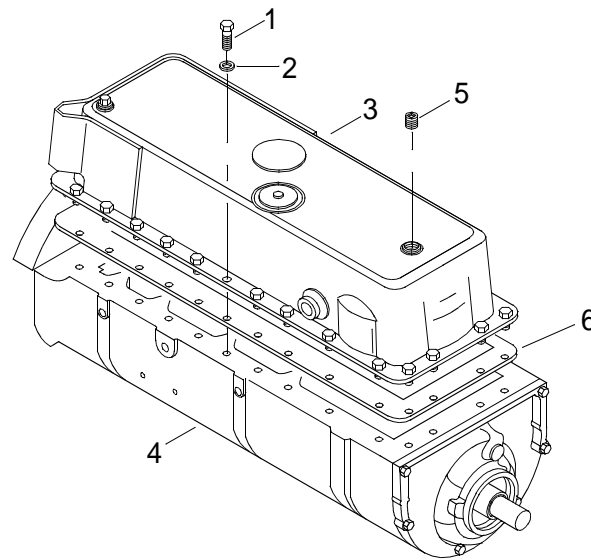

2. Remove oil pan (3) from engine block (4).
3. Remove drain plug (5) from oil pan (3) and set aside for re-installation.
4. Discard oil pan (3).
5. Remove old gasket (6) and discard.
6. Using scraper, clean the old gasket material from the cylinder block (4).

INSTALL LUBE OIL PAN

CAUTION

The stamped metal oil pan used on marine engines have a thin, protective coating on the outer surface to shield the metal against salt water corrosion. Do not rest, slide or otherwise scratch the outer surface of the oil pan or electrolysis will take place and corrosion to the oil pan will result.

1. Using cleaner, clean the new oil pan (3).

WARNING

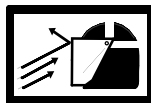

FLYING PARTICLES

CAUTION

When drying oil pan with compressed air, do not exceed 40 PSI (279.79 kPa). Failure to comply will cause damage to the protective coating.

2. Dry oil pan (3) with compressed air.

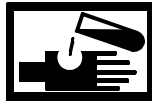
WARNING**CHEMICAL****EYE PROTECTION**

3. Apply sealing compound to the mating surface of oil pan (3).

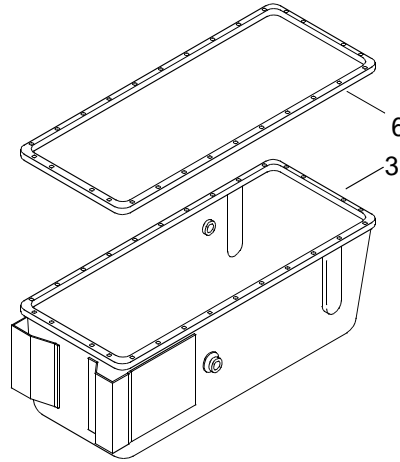

4. Align holes in gasket (6) with holes in oil pan (3) and position gasket on oil pan surface.
5. Align holes in oil pan (3) with holes in engine block (4) and position oil pan with gasket on engine block.

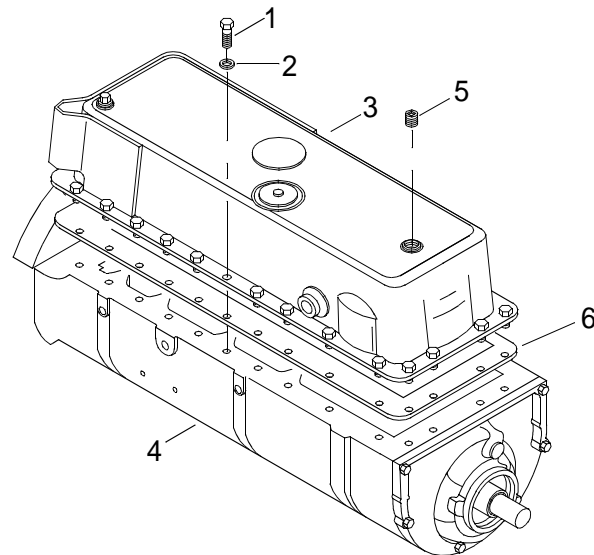

WARNING

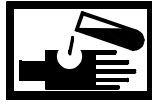
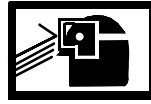
**CHEMICAL****EYE PROTECTION**

CAUTION

Do not overtighten oil pan bolts. Failure to comply could damage oil pan and gasket.

6. Apply adhesive to the threads of the oil pan bolts (1) and install the center bolt on each side of the oil pan (3).
7. Continue installing remaining (22) bolts, alternately, on either side of the pan working toward each end of the oil pan (3).
8. Using a torque wrench and socket set, torque bolts (1) to 120-240 in. lbs (14-27 N-m), working from center and alternating side, towards each end of the oil pan (3).

WARNING

**CHEMICAL****EYE PROTECTION**

9. Coat threads of drain plug (5) thread with adhesive.
10. Install drain plug (5) into the new oil pan (3)
11. Using a torque wrench and socket set, torque drain plug (6) to 300-420 in. lbs (34-47 N-m) of torque.
12. Remove engine from stand. (WP 0032 00)
13. Install lube oil cooler. (WP 0128 00)
14. Install marine gear oil cooler mounting bracket. (WP 0164 00)
15. Install overspeed governor. (WP 0175 00)
16. Install lube oil dipstick tube assembly. (WP 0130 00)
17. Install starter motor. (WP 0170 00)
18. Install air box drains. (WP 0036 00)
19. Install air box covers. (WP 0035 00)
20. Install fuel cooler. (WP 0081 00)
21. Install marine gear oil cooler. (TM 55-1945-205-24-1-3)
22. Install exhaust manifolds. (WP 0163 00)

-
23. Install turbochargers. (WP 0114 00)
 24. Install air inlet collector assembly. (WP 0104 00)
 25. Install crankcase breather limiter assembly. (WP 0106 00)

END OF WORK PACKAGE

**DIRECT SUPPORT MAINTENANCE
CAUSEWAY FERRY
LUBE OIL COOLER
REMOVAL, CLEANING, INSPECTION, AND INSTALLATION**

INITIAL SETUP:**Tools**

Tool Kit, General Mechanic's
(Item 130, WP 0188 00)
Pan, Drain (Item 87, WP 0188 00)
Qty 2
Goggles, Industrial (Item 54 WP 0188 00)
Gloves, Chemical (Item 52, WP 0188 00)
Apron, Utility (Item 8, WP 0188 00)
Respirator, Air Filtering (Item 109, WP 0188 00)
Stud, 8½ in long, 5/16 in - 18 thread
(Item XX, WP 0188 00)
Qty 2

Materials/Parts

Gasket
(72582)
NSN 5330-00-758-2881
PN 5117317
Gasket
(72582)
NSN 5330-01-321-9652
PN 23501589
Gasket
(72582)
NSN 5330-01-303-5436
PN 23501584
Gasket
(72582)
NSN 5330-00-758-2863
PN 8926782
Qty 4

Materials/Parts (Cont'd)

Seal
(72582)
NSN 5330-01-058-5220
PN 5102098
Antifreeze (Item 5, WP 0187 00)
Cleaner, Type II (Item 08, WP 0187 00)
Cloth, Cleaning (Item 13, WP 0187 00)
Spill Clean-up Kit, Hazardous Material
(Item 32, WP 0187 00)
Lubricating Oil, Engine
(Item 25 WP 0187 00)

Personnel Required

Engineer 88L

References

TM 55-1945-205-10-1

Equipment Condition

Fresh Water Cooling System Drained (WP 0134 00)
Marine Gear Oil Cooler Removed. (TM 55-1945-205-24-1-3)
Marine Gear Oil Cooler Mounting Bracket Removed. (WP 0164 00)
Overspeed Governor Removed. (WP 0175 00)
Engine Cool To Touch.

REMOVE OIL COOLER**NOTE**

Removal of the oil cooler is typical for the port and starboard engines.

1. Verify MAIN circuit breaker (1) on the propulsion module circuit breaker panel A6 is off.

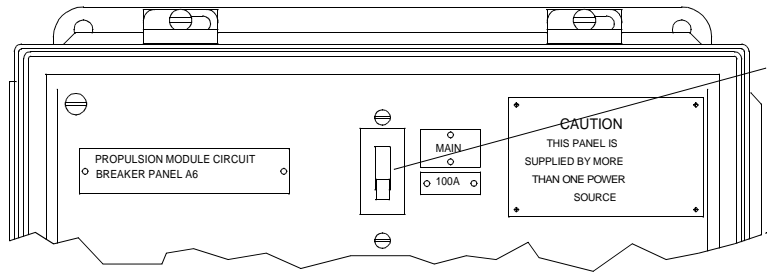

WARNING



CHEMICAL



EYE PROTECTION

- Position drain pan under oil filter supply line (2) and return line (3).

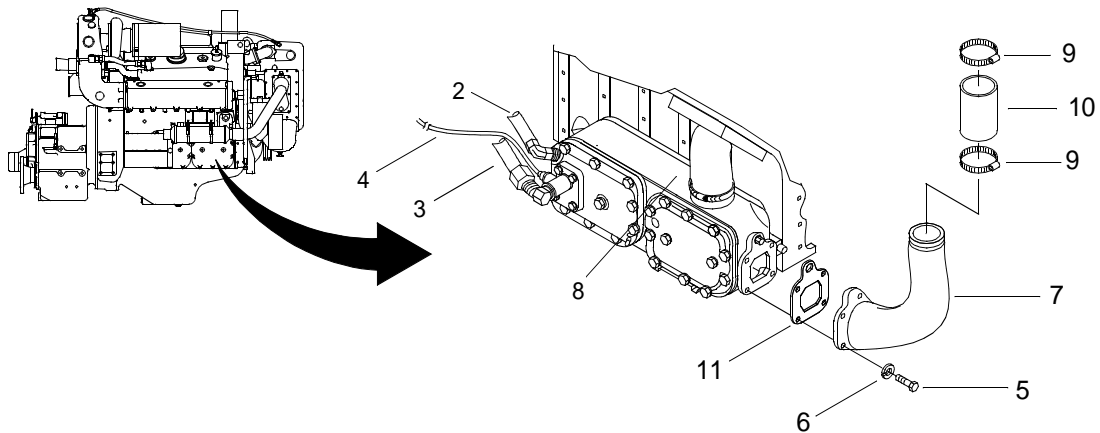

WARNING



CHEMICAL



EYE PROTECTION

- Disconnect oil filter supply (2) and return line (3).
- Disconnect oil temperature switch electrical connector (4).

WARNING



CHEMICAL



EYE PROTECTION

- Allow oil to drain into drain pan.

WARNING**CHEMICAL****EYE PROTECTION**

6. Remove two bolts (5) and lock washers (6) that secure water inlet elbow (7) to oil cooler housing (8).
7. Loosen two clamps (9) and slide over hose (10).
8. Remove elbow (7).
9. Remove hose (10).
10. Remove gasket (11) and discard.
11. Loosen clamp (12) and slide over water outlet elbow (13).

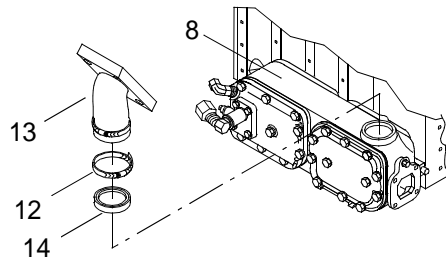

12. Disconnect water outlet elbow (13) from oil cooler housing (8).
13. Remove seal (14) and discard.
14. Remove two bolts (15) and copper washers (16) centered on the top of and securing cover plates (17) and oil cooler housing (8) to oil cooler mounting plate (18).

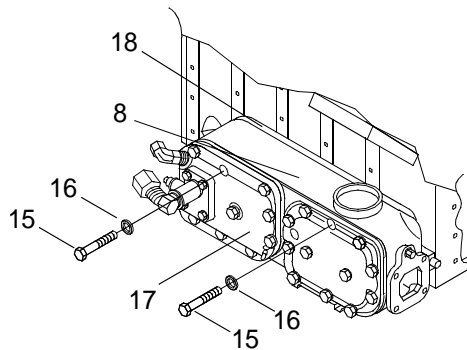

15. Install two studs (19) into oil cooler mounting plate (18) through holes (20).

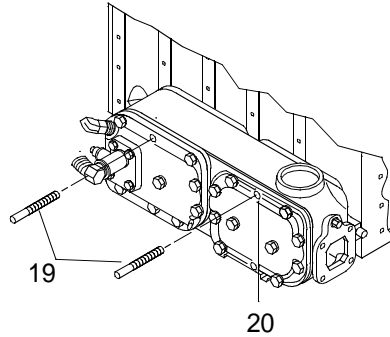

NOTE

Before removing the following bolt, note its location as it is smaller than remaining bolts and must be set aside for installation in same location.

16. Remove bolt (21) and washer (22) from cover plate (17).

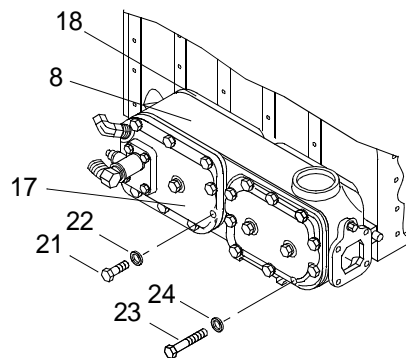

17. Remove remaining twenty four cover bolts (23) and lock washers (24) securing cover plates (17) and oil cooler housing (8) to oil cooler mounting plates (18).

CAUTION

Use care when removing the oil cooler not to drop the oil cooler core assembly or damage to oil cooler core may occur.

18. Slide two cover plates (17), two gaskets (25), oil cooler core (26) and two gaskets (27) off of previously installed studs (19) on oil cooler housing (8).

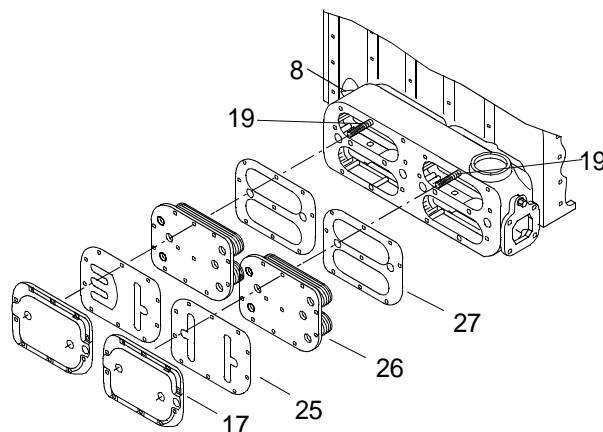

19. Discard gaskets (25, 27).

NOTE

Mounting bolt and washer is located in the very small space between the block and the oil cooler mounting plate.

20. Remove small mounting bolt (28) and washer (29) securing oil cooler housing (8) to aft mounting plate (18).

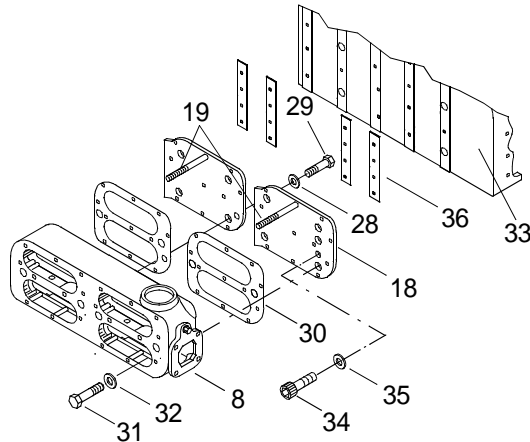

21. Slide oil cooler housing (8) off of previously installed studs (19).
22. Remove and discard two gaskets (30).
23. Remove two previously installed studs (19).
24. Remove eight bolts (31) and eight washers (32) securing two mounting plates (18) to engine block (33).
25. Remove key socket head screw (34) and washer (35) from forward oil cooler mounting plate (18).
26. Remove two mounting plates (18).
27. Remove metal spacers (36) and retain.

CLEAN OIL COOLER CORE

WARNING

Perform this operation in the open or in a well ventilated room. Avoid breathing the fumes or direct contact of the chemicals with your skin. Failure to comply could result in serious injury to personnel.

NOTE

Do not attempt to clean an oil cooler core when an engine failure occurs and metal particles from worn or broken parts are released into the lubricating oil. Should such condition arise, replace the oil cooler core.

1. Using cleaner and a force pump, clean oil passages in the oil cooler core (26).

WARNING

**CHEMICAL****EYE PROTECTION**

- a. Using a force pump, clean the oil passages in the oil cooler core (26) by circulating cleaner through the passages before the sludge hardens.

WARNING

**CHEMICAL****EYE PROTECTION**

- b. If the oil passages are badly clogged, reclean by circulating cleaning compound solution through the oil cooler core (26) oil passages. Replace cleaner as necessary until cleaner coming out of passages is free of dirt and debris.
- c. Flush thoroughly with clean, hot water.

WARNING

Perform this operation in the open or in a well ventilated room. Avoid breathing the fumes or direct contact of the chemicals with your skin. Failure to comply could result in serious injury to personnel.

NOTE

Do not attempt to clean an oil cooler core when an engine failure occurs and metal particles from worn or broken parts are released into the lubricating oil. Should such a condition arise, replace the oil cooler core.

2. Using cleaner, clean the water side of the oil cooler core (26).
 - a. Allow oil cooler core to soak in cleaner until deposits are softened.
 - b. Thoroughly flush the oil cooler core (26) with clean, hot water.

WARNING

**CHEMICAL****EYE PROTECTION**

3. Dip the oil cooler core (26) in light oil.

INSPECT OIL COOLER**NOTE**

Repair is limited to the replacement of defective parts.

1. Inspect the oil cooler core for corrosion, cracks or blocked passages. Replace as necessary.
2. Inspect the oil cooler covers (17) for damage that would render the covers unusable. Replace as necessary.
3. Inspect the mounting plates (18) for damage that would render the mounting plate unusable. Replace as necessary.
4. Inspect the oil cooler housing (8) for holes, dents and any other damage that would render the housing unusable. Replace as necessary.
5. Inspect mounting hardware for serviceability. Replace as necessary.
6. Inspect oil in drain pan for antifreeze contamination. Replace oil cooler cores, filters and oil as necessary.

WARNING**CHEMICAL****EYE PROTECTION**

7. Remove drain pan and dispose of contents in accordance with local procedures.

INSTALL OIL COOLER**NOTE**

Installation of the oil cooler is typical for the port and starboard engines.

1. Position bolt (28) and washer (29) in left oil cooler mounting plate (18).

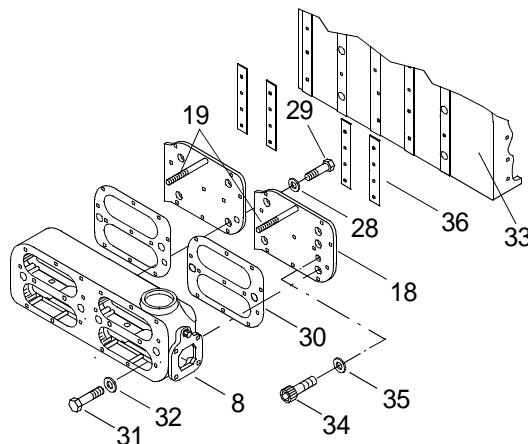

2. Install two mounting plates (18) and metal spacers (36) on engine block (33).
3. Install eight washers (32) and eight bolts (31) through oil cooler mounting plates (18) into engine block (33).

4. Tighten eight bolts (31).
5. Install key socket head screw (34) and washer (35) in forward oil cooler mounting plate (18).
6. Tighten key socket head screw (34).
7. Install studs (19) in top center hole of both oil cooler mounting plates (18).
8. Install two new gaskets (30) over previously installed studs (19).
9. Install oil cooler housing (8) over previously installed studs (19).
10. Install washer (29) and small mounting bolt (28) through mounting plate (30) into the back of oil cooler housing (8).

CAUTION

Use care when installing the oil cooler not to drop the core assembly as damage to cooler may occur.

11. Install two new gaskets (27), oil cooler core (26), two new gaskets (25) and cover plates (17) over previously installed studs (19) on housing (8).

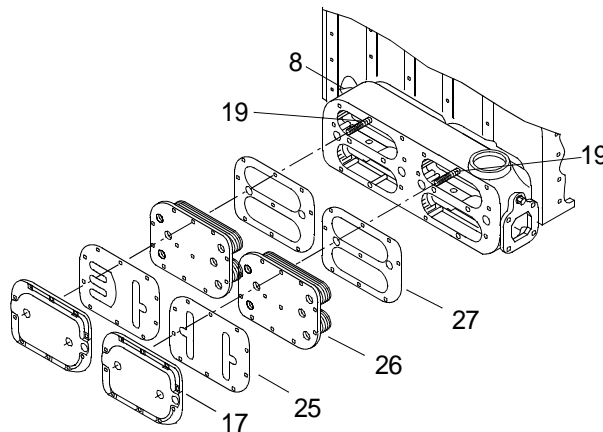

12. Install washer (22) and smaller bolt (21), as noted during removal.

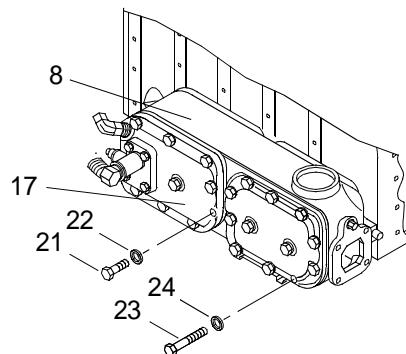

13. Install remaining twenty four lock washers (22) and bolts (23) through cover plates (17) and housing (8) into oil cooler mounting plate (18).
14. Tighten twenty four bolts (23).

15. Tighten bolt (28).
16. Tighten bolt (21).
17. Remove two studs (19) from holes (20) in engine block.

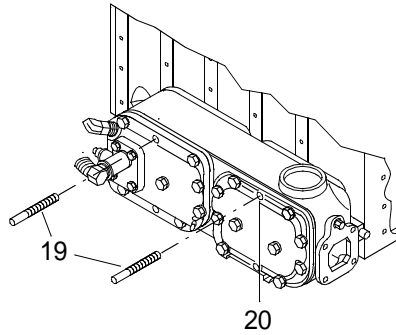

18. Install four copper washers (16) and four bolts (15), centered on the top through cover plates (17) and housing (8) into oil cooler mounting plate (18).

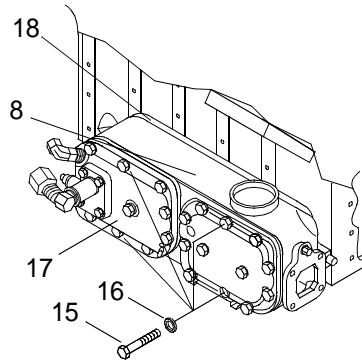

19. Tighten two bolts (15).
20. Install new seal (14) on oil cooler housing (8).

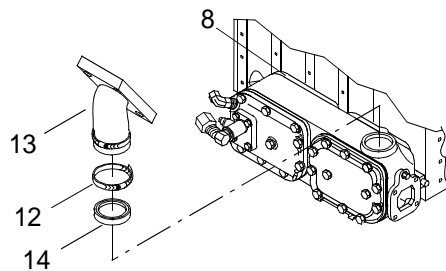

21. Slide clamp (12) over elbow (13) and seal (14).
22. Tighten clamp (12).

23. Install new gasket (11) and position water inlet elbow (7) on oil cooler housing (8).

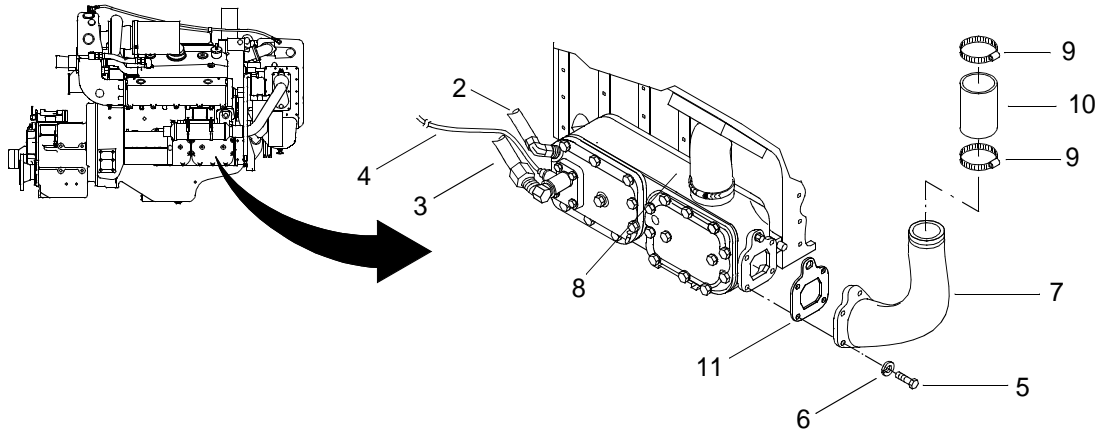

24. Install lock washers (6) and four bolts (5) through water inlet elbow (7) and gasket (11) into oil cooler housing (8).

25. Tighten four bolts (5).

26. Install hose (10) and slide two clamps (9) in place on hose (10).

27. Tighten two clamps (9).

28. Connect oil temperature switch electrical connector (4).

29. Connect oil filter supply line (2) and return line (3).

30. Install overspeed governor. (WP 0175 00)

31. Install marine gear oil cooler mounting bracket. (WP 0164 00)

32. Install marine gear oil cooler. (TM 55-1945-205-24-1-3)

33. Service engine fresh water cooling system. (WP 0133 00)

WARNING



CHEMICAL

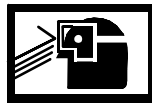

EYE PROTECTION



VAPOR



SLICK FLOOR

34. Clean up spilled fluid with a spill kit and dispose of spill kit waste in accordance with local procedures.

35. Service lube oil system. (WP 0115 00)

36. Perform operational checks. (TM 55-1945-205-10-1)

END OF WORK PACKAGE

**UNIT LEVEL MAINTENANCE
CAUSEWAY FERRY
LUBE OIL COOLER BYPASS VALVE
REMOVAL, CLEANING, INSPECTION AND INSTALLATION**

INITIAL SETUP:**Tools**

Tool Kit, General Mechanic's (Rail and Marine) (Item 130, WP 0188 00)
Tester, Spring Resiliency (Item 124, WP 0188 00)
Goggles, Industrial (Item 54, WP 0188 00)
Gloves, Chemical (Item 52, WP 0188 00)
Wrench, Torque (150-750 in. lbs) (Item 142, WP 0188 00)
Wrench Set, Socket (3/8 in. sqdr.) (Item 135, WP 0188 00)
Compressor Unit, Reciprocating, Power Drive (Item 27, WP 0188 00)

Materials/Parts

Gasket
(72582)
PN 5177773
Cleaning Compound, (Item 10, WP 0187 00)

Personnel Required

Engineer 88L

References

TM 55-1945-205-10-1

Equipment Condition

Engine Cool To Touch.
Marine Gear Oil Cooler Removed. (TM 55-1945-205-24-1-3)
Marine Gear Oil Cooler Mounting Bracket Removed. (WP 0164 00)
Overspeed Governor Removed. (WP 0175 00)
Engine Oil Cooler Removed. (WP 0128 00)

REMOVE OIL COOLER BYPASS VALVE

WARNING

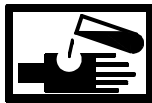

CHEMICAL



EYE PROTECTION

1. Remove retaining plug (1) from the engine oil cooler adaptor (2).

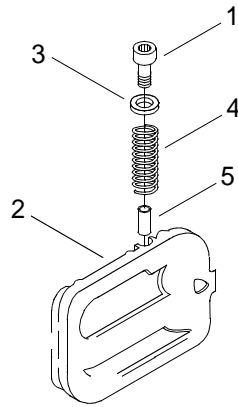

WARNING



CHEMICAL

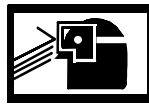

EYE PROTECTION

2. Remove gasket (3) from retaining plug (1) and discard gasket (3).

WARNING



CHEMICAL

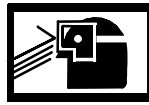

EYE PROTECTION

3. Remove bypass valve spring (4) from the engine oil cooler adaptor valve cavity (2).

WARNING

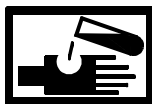

CHEMICAL



EYE PROTECTION

4. Remove bypass valve (5) from the engine oil cooler adaptor valve cavity (2).

CLEAN OIL COOLER BYPASS VALVE

WARNING



CHEMICAL



EYE PROTECTION

1. Clean oil bypass valve (5) and bypass valve spring (4) with cleaning compound.

WARNING

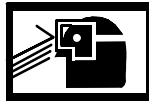
**EYE PROTECTION**

2. Dry with compressed air not to exceed 40 PSI (279.79 kPa) air pressure.

INSPECT OIL COOLER BYPASS VALVE

1. Inspect spring (4) for wear. Replace defective part.

NOTE

The bypass valve spring has a free length of approximately 2 1/64th in. (5.11 cm).

2. Using spring tester, apply a force of 12 lbs (5.45 kg) to the spring.
3. Check length of spring (4) for a minimum allowable length of 1.793 in. (4.55 cm). Replace defective part.
4. Inspect bypass valve (5) for pitting and corrosion. Replace defective part.
5. Inspect retainer plug (1) for stripped or damaged threads. Replace defective part.

INSTALL OIL COOLER BYPASS VALVE

1. Install bypass valve (5) in the oil cooler adaptor valve cavity (2), closed end first.

NOTE

Ensure the spring is placed inside of the bypass valve on installation.

2. Install the bypass valve spring (4) in the oil cooler adaptor valve cavity (2).
3. Install a new gasket (3) on the retainer plug (1).

NOTE

A slotted bypass valve plug is used with the oil cooler adaptor plug on some engines.
Torque this plug to 300 - 420 in. lbs (34 - 41 N-m).

4. Install retaining plug (1) in the oil cooler adaptor valve cavity (2) and tighten plug (1).
5. Using torque wrench and socket set, torque the retainer plug (1) to 360-480 in. lbs (41-54 N-m).
6. Install lube oil cooler. (WP 0128 00)
7. Install overspeed governor. (WP 0175 00)
8. Install marine gear oil cooler mounting bracket. (WP 0164 00)
9. Install marine gear oil cooler. (TM 55-1945-205-24-1-3)
10. Perform operational checks. (TM 55-1945-205-10-1)

END OF WORK PACKAGE

**UNIT LEVEL MAINTENANCE
CAUSEWAY FERRY
LUBE OIL DIPSTICK TUBE ASSEMBLY
REPLACEMENT**

INITIAL SETUP:

Tools

Tool Kit, General Mechanic's (Rail and Marine) (Item 131, WP 0188 00)

Materials/Parts

Tube Assembly
(72582)

PN 23509424

O-Ring

(72582)

NSN 5331-01-420-8670

PN 23504352

Personnel Required

Engineer 88L

References

TM 55-1945-205-10-1

REMOVE LUBE OIL DIPSTICK TUBE ASSEMBLY

1. Verify MAIN circuit breaker (1) on propulsion module circuit breaker panel A6 is off.

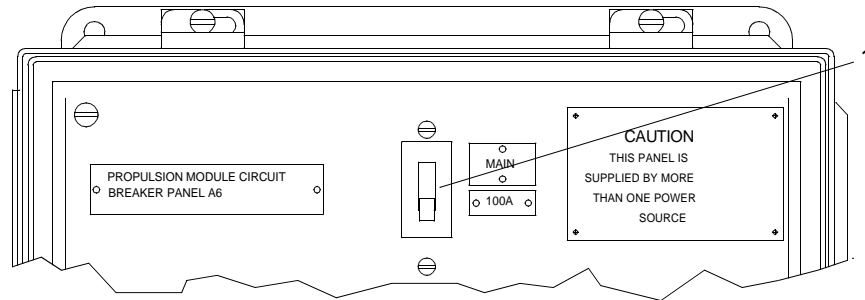

2. Remove oil level dipstick (2) from lube oil dipstick tube assembly (3).

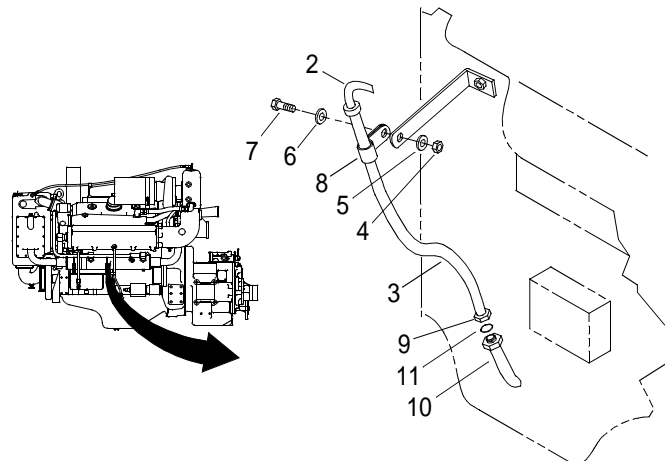

3. Remove nut (4), lock washer (5), washer (6) and bolt (7) from clamp (8).
4. Remove clamp (8) from lube oil dipstick tube assembly (3).
5. Loosen captive nut (9) and remove lube oil dipstick tube assembly (3) from oil pan guide (10).
6. Remove o-ring (11) from lube oil dipstick tube assembly (3).
7. Discard lube oil dipstick tube assembly (3) and o-ring (11).

INSTALL LUBE OIL DIPSTICK TUBE ASSEMBLY

1. Install new o-ring (11) on new lube oil dipstick tube assembly (3).
2. Install lube oil dipstick tube assembly (3) in oil pan guide (10) and tighten captive nut (9).
3. Install clamp (8) on lube oil dipstick tube assembly (3).
4. Install bolt (7), washer (6), lock washer (5) and nut (4) in clamp (8). Tighten nut (4).
5. Install oil level dipstick (2) in lube oil dipstick tube assembly (3).
6. Perform operational checks. (TM 55-1945-205-10-1)

END OF WORK PACKAGE

**UNIT LEVEL MAINTENANCE
CAUSEWAY FERRY
LUBE OIL PRESSURE SENDING UNIT
REPLACEMENT**

INITIAL SETUP:**Tools**

Tool Kit, General Mechanic's (Rail and Marine) (Item 131, WP 0188 00)
 Gloves, Chemical (Item 52, WP 0188 00)
 Goggles, Industrial (Item 54, WP 0188 00)
 Pan, Drain (Item 87, WP 0188 00)

Materials/Parts

Oil Pressure Sending Unit
 (72582)
 PN 1SD41624
 Tape, Antiseize (Item 34, WP 0187 00)
 Spill Clean-Up Kit, Hazardous Material (Item 32, WP 0187 00)s

Personnel Required

Engineer 88L

References

TM 55-1945-205-10-1

REMOVE LUBE OIL PRESSURE SENDING UNIT

1. Verify MAIN circuit breaker (1) on propulsion module circuit breaker panel A6 is off.

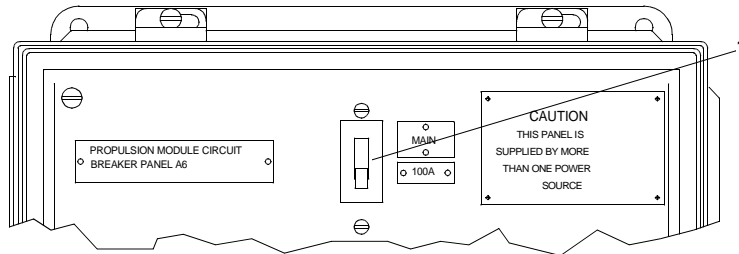

2. Tag and disconnect two wires (2) from oil pressure sending unit (3).

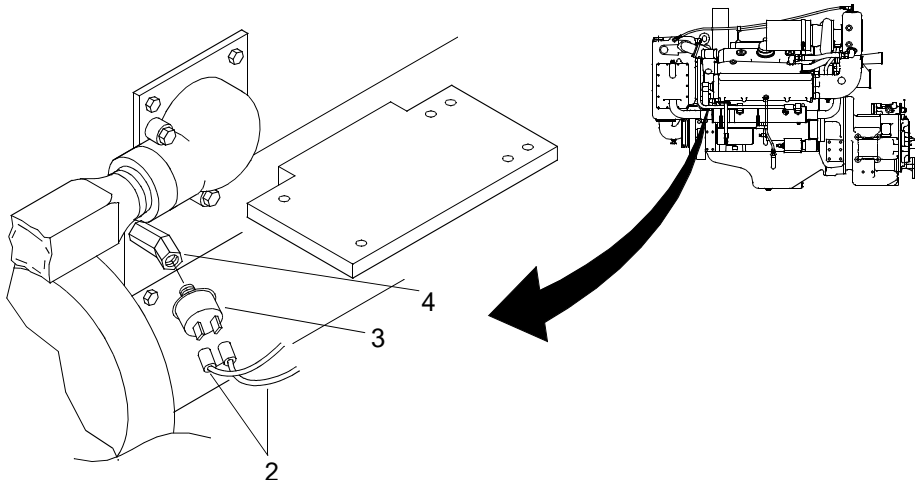

-
3. Position drain pan under sending unit (3).

WARNING



CHEMICAL



EYE PROTECTION

4. Remove oil pressure sending unit (3) from street elbow (4). Discard sending unit.

INSTALL LUBE OIL PRESSURE SENDING UNIT

1. Wrap new oil pressure sending unit (3) threads with antiseize tape.
2. Install new oil pressure sending unit (3) into street elbow (4).

WARNING

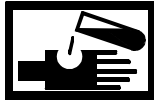

CHEMICAL

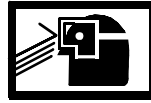

EYE PROTECTION

3. Remove drain pan and dispose of contents in accordance with local procedures.
4. Observing tags, connect two wires (2) to oil pressure sending unit (3).
5. Remove tags from wires (2).

WARNING



CHEMICAL

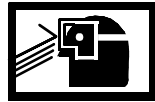

EYE PROTECTION



SLICK FLOOR

6. Clean spilled fluid with spill kit and dispose of spill kit waste in accordance with local procedures.
7. Perform operational check of diesel engine. (TM 55-1945-205-10-1)

END OF WORK PACKAGE

**UNIT LEVEL MAINTENANCE
CAUSEWAY FERRY
LUBE OIL TEMPERATURE SWITCH
REPLACEMENT**

INITIAL SETUP:**Tools**

Tool Kit, General Mechanic's (Rail and Marine) (Item 131, WP 0188 00)
Gloves, Chemical (Item 52, WP 0188 00)
Goggles, Industrial (Item 54, WP 0188 00)
Pan, Drain (Item 87, WP 0188 00)

Materials/Parts

Sending Unit, Engine Oil Temperature
(72582)
PN 1SD41622
Tape, Antiseize (Item 34, WP 0187 00)
Spill Clean-up Kit, Hazardous Material (Item 32 WP 0187 00)

Personnel Required

Engineer 88L

References

TM 55-1945-205-10-1

Equipment Condition

Engine Cool To Touch.

REMOVE LUBE OIL TEMPERATURE SWITCH

1. Verify MAIN circuit breaker (1) on propulsion module circuit breaker panel A6 is off.

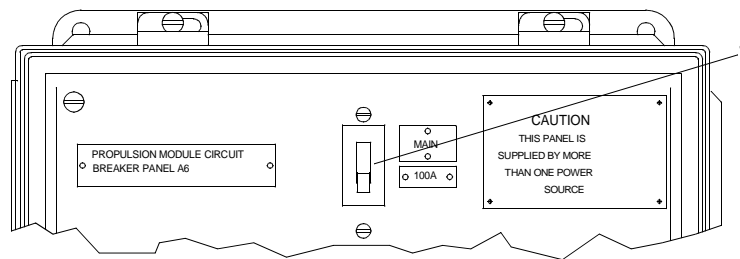

2. Tag and disconnect two wires (2) from lube oil temperature switch (3).

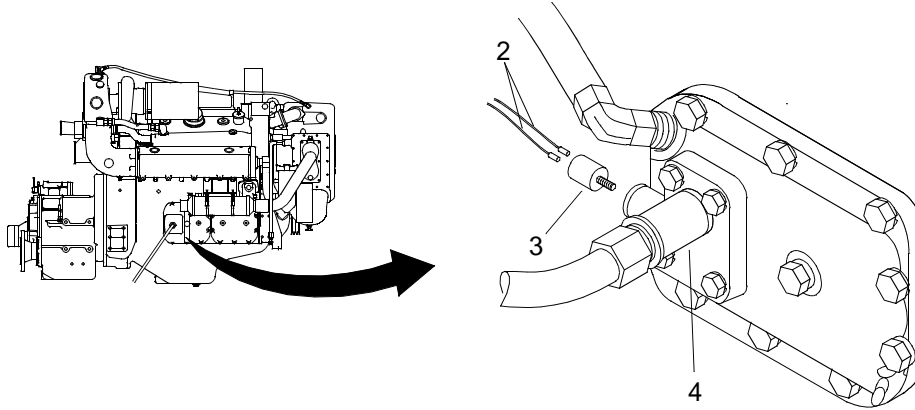

3. Position a drain pan under lube oil temperature switch (3).

WARNING



CHEMICAL

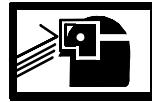

EYE PROTECTION

4. Unscrew lube oil temperature switch (3) from oil return line tee fitting (4). Discard switch.

INSTALL LUBE OIL TEMPERATURE SWITCH

1. Wrap new lube oil temperature switch (3) threads with antiseize tape.
2. Install lube oil temperature switch (3) into oil return line tee fitting (4).

WARNING



CHEMICAL



EYE PROTECTION

3. Remove drain pan and dispose of contents in accordance with local procedures.
4. Connect wires (2) to lube oil temperature switch (3).
5. Remove tags from wires (2).

WARNING

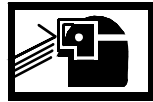
**CHEMICAL****EYE PROTECTION****SLICK FLOOR**

6. Clean spilled fluid with spill kit and dispose of spill kit waste in accordance with local procedure.
7. Perform operational check of diesel engine. (TM 55-1945-205-10-1)

END OF WORK PACKAGE

**UNIT LEVEL MAINTENANCE
CAUSEWAY FERRY
FRESH WATER COOLING SYSTEM
SERVICING**

INITIAL SETUP:**Tools**

Goggles, Industrial (Item 54, WP 0188 00)
Respirator (Item 109, WP 0188 00)
Gloves, Chemical (Item 52, WP 0188 00)
Apron, Utility (Item 8, WP 0188 00)

Materials/Parts

Antifreeze (Item 5, WP 0187 00)
Water, Reagent Distilled (Item 38, WP 0187 00)

Personnel Required

Engineer 88L

References

TM 55-1945-205-10-1
TB 55-1900-207-24

Equipment Condition

Heat Exchanger Cool To Touch.

SERVICE FRESH WATER COOLING SYSTEM

1. Verify MAIN circuit breaker (1) on the propulsion module circuit breaker panel A6 is off.

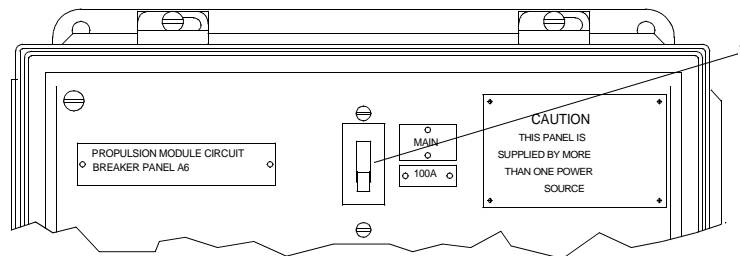

WARNING



CHEMICAL



EYE PROTECTION



POISON



VAPOR

2. Prepare a 50/50 solution of antifreeze and distilled water. (TB 55-1900-207-24)

WARNING

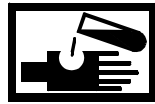

CHEMICAL

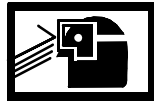

EYE PROTECTION



POISON



VAPOR

- Remove pressure control cap (2) from heat exchanger (3) by pressing down and rotating counterclockwise.

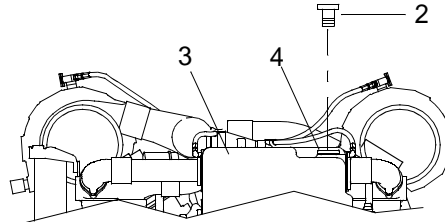

WARNING



CHEMICAL



EYE PROTECTION



POISON



VAPOR

- Add solution through heat exchanger opening (4) until solution is within 1 in. from the top of heat exchanger (3).
- Install pressure control cap (2) by pressing down on and rotating clockwise.
- Start engine. (TM 55-1945-205-10-1)
- Operate engine for five minutes or until it reaches normal operating temperature.
- Shut down engine. (TM 55-1945-205-10-1)

WARNING



HOT AREA

- Let engine cool to touch.

WARNING

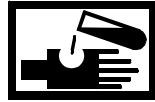
**CHEMICAL****EYE PROTECTION****POISON****VAPOR**

Do not remove the pressure control cap from heat exchanger until engine has cooled. Sudden release of pressure can result in injury to personnel and loss of coolant.

10. Remove pressure control cap (2) from heat exchanger (3) by pressing down and rotating counterclockwise.
11. Verify solution level is within 1 in. from the top of heat exchanger.

WARNING

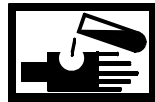
**CHEMICAL****EYE PROTECTION****POISON****VAPOR**

12. Add solution through opening (4) in heat exchanger (3) until solution is within 1 in. from the top of the heat exchanger, as necessary.
13. Install pressure control cap (2) by pressing down on and rotating clockwise.
14. Perform operational checks. (TM 55-1945-205-10-1)

END OF WORK PACKAGE

**UNIT LEVEL MAINTENANCE
CAUSEWAY FERRY
FRESH WATER COOLING SYSTEM
FLUSH**

INITIAL SETUP:**Tools**

Tool Kit, General Mechanic's (Rail and Marine) (Item 131, WP 0188 00)
 Gloves, Chemical (Item 52, WP 0188 00)
 Goggles, Industrial (Item 54, WP 0188 00)
 Pan, Drain (Item 87, WP 0188 00)
 Qty 4
 Apron, Utility (Item 8, WP 0188 00)
 Respirator, Air Filtering (Item 109, WP 0188 00)
 Protector, Hearing (Item 98, WP 0188 00)

Materials/Parts

Antifreeze (Item 5, WP 0187 00)
 Cleaning Compound, Engine Cooling System (Item 09, WP 0187 00)
 Compound, Corrosion Preventive (Item 16, WP 0187 00)
 Water, Distilled (Item 38, WP 0187 00)
 Spill Clean-up Kit, Hazardous Material (Item 32, WP 0187 00)

Personnel Required

Engineer 88L

References

TM 55-1945-205-10-1
 TB 55-1900-207-24

Equipment Condition

Engine Cool To Touch.

DRAIN COOLING SYSTEM

1. Verify MAIN circuit breaker (1) on propulsion module circuit breaker panel A6 is off.

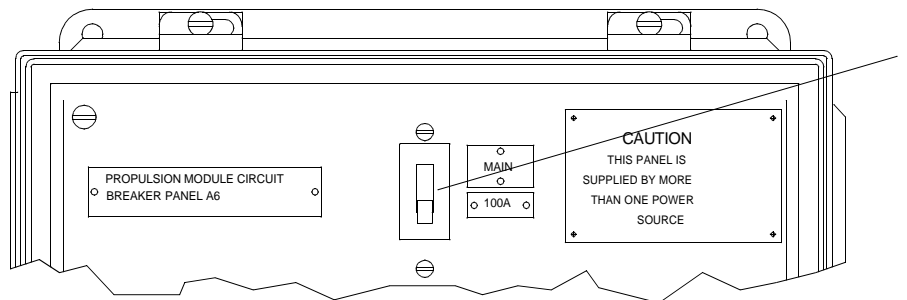

- Remove pressure control cap (2) from heat exchanger (3) by pressing down and rotating counterclockwise.

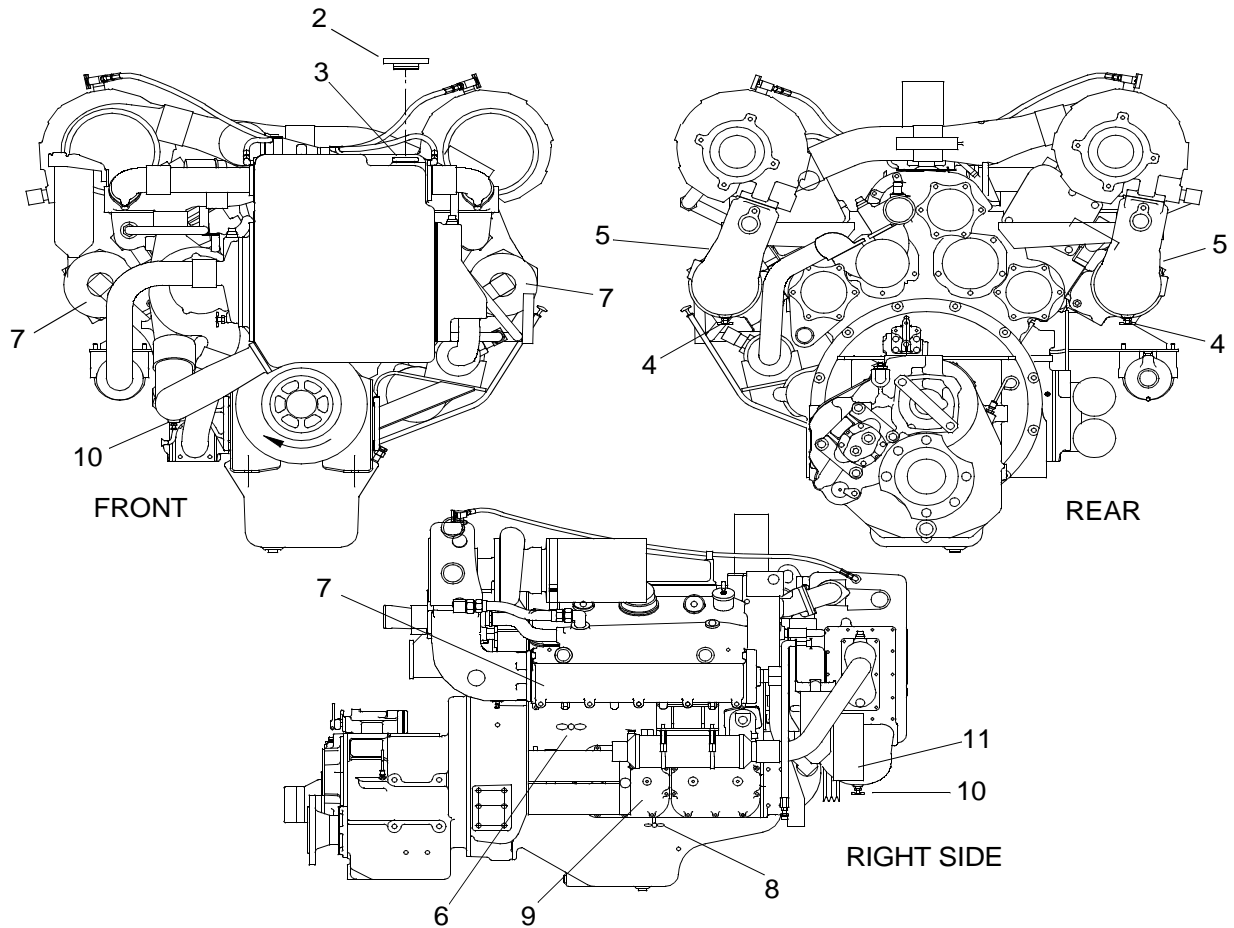

- Position drain pan under drain cocks (4) below right and left exhaust manifold elbows (5).

WARNING

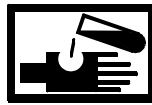

CHEMICAL

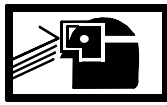

EYE PROTECTION



POISON



VAPOR

- Open two drain cocks (4) on right and left side of engine and drain coolant into drain pan.
- Position drain pan under drain cocks (6) located on right and left side of cylinder block below exhaust manifolds (7).

WARNING

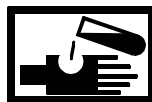

CHEMICAL



EYE PROTECTION



POISON



VAPOR

- Open two drain cocks (6) on right and left side of engine and drain coolant into drain pan.

7. Position drain pan under drain cock (8) at the bottom of oil cooler (9).

WARNING



CHEMICAL



EYE PROTECTION



POISON



VAPOR

8. Open drain cock (8) and drain coolant into drain pan.
9. Position drain pan under drain cock (10) below heat exchanger (11).

WARNING



CHEMICAL



EYE PROTECTION



POISON



VAPOR

10. Open drain cock (10) and drain coolant into drain pan.

WARNING



CHEMICAL

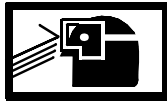

EYE PROTECTION



POISON



VAPOR

11. Close drain cocks (4, 6, 8) and (10).

WARNING



CHEMICAL



EYE PROTECTION



POISON



VAPOR

12. Remove drain pans and dispose of contents in accordance with local procedures.

CLEAN AND FLUSH COOLING SYSTEM**WARNING****CHEMICAL****EYE PROTECTION****POISON****VAPOR**

1. Prepare a solution of engine cooling system cleaner in accordance with kit instructions.

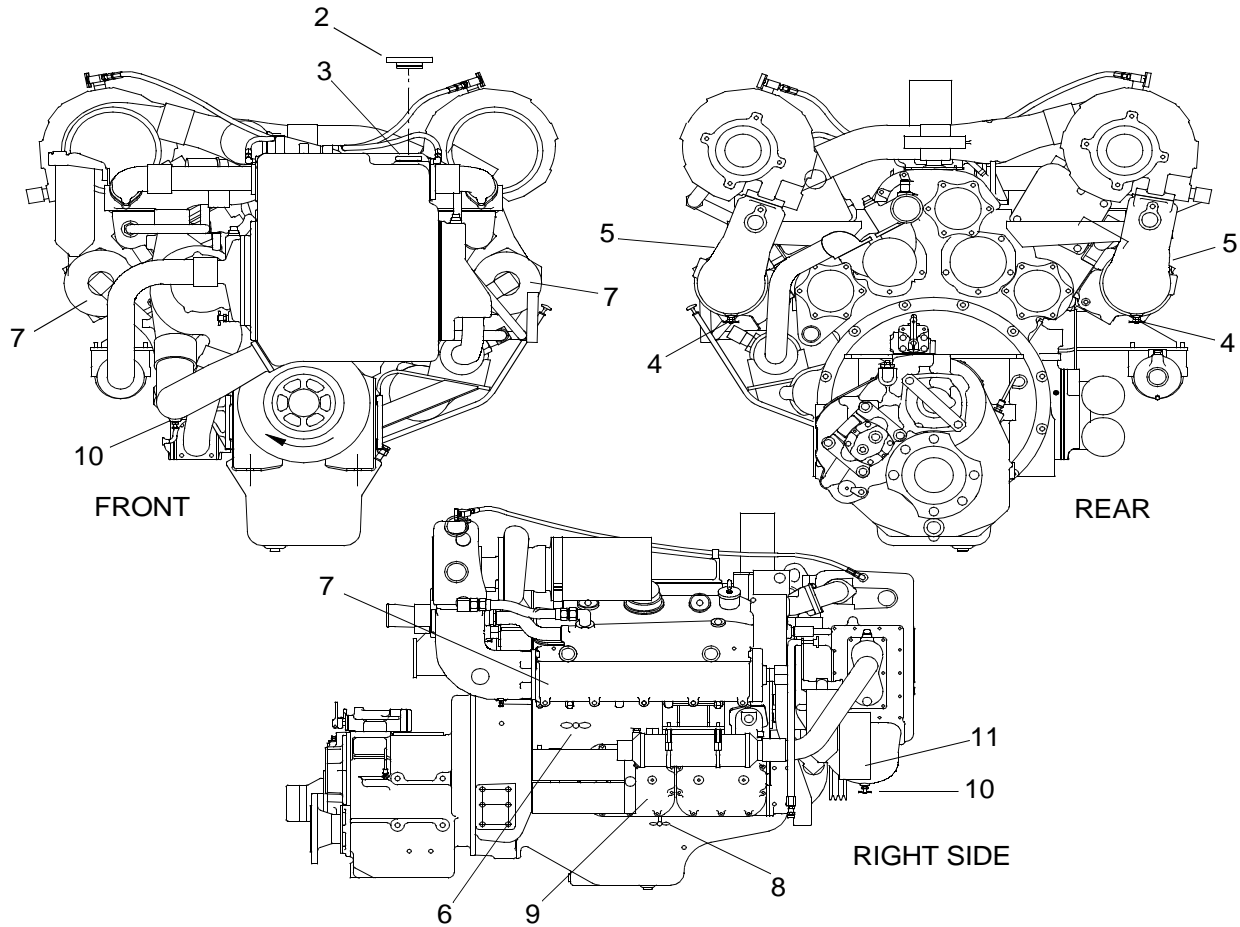

2. Remove engine thermostats and reinstall thermostat covers. (WP 0143 00)

WARNING**CHEMICAL****EYE PROTECTION****POISON****VAPOR**

3. Fill cooling system with engine cooling system cleaning solution, through heat exchanger fill neck (3), until solution level is 1 in. below fill neck (3).

4. Install pressure control cap (2) by pressing down and rotating clockwise.

WARNING



EAR PROTECTION

5. Start engine. (TM 55-1945-205-10-1)

WARNING



EAR PROTECTION

6. After engine reaches normal operating temperature, run engine for five minutes.
7. Shut down engine. (TM 55-1945-205-10-1)
8. Drain cooling system completely.

WARNING



HOT AREA

Do not remove the pressure control cap from heat exchanger or attempt to drain the solution until engine has cooled. Sudden release of pressure can result in loss of solution and possible injury to personnel.

- a. Remove pressure control cap (2) from heat exchanger (3) by pressing down and rotating counterclockwise.
- b. Position drain pan under drain cocks (4) below right and left exhaust manifold elbows.

WARNING



CHEMICAL



EYE PROTECTION



POISON



VAPOR

- c. Open two drain cocks (4) on right and left side of engine and drain cleaning solution into drain pan.
- d. Position drain pan under drain cocks (6) located on right and left side of cylinder block below exhaust manifolds (7).

WARNING

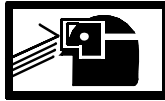
**CHEMICAL****EYE PROTECTION****POISON****VAPOR**

- e. Open two drain cocks (6) on right and left side of engine and drain cleaning solution into drain pan.
- f. Position drain pan under drain cock (8) at bottom of oil cooler (9).

WARNING

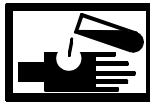
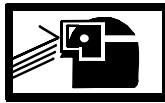
**CHEMICAL****EYE PROTECTION****POISON****VAPOR**

- g. Open drain cock (8) and drain cleaning solution into drain pan.
- h. Position drain pan under drain cock (10) below heat exchanger (11).

WARNING

**CHEMICAL****EYE PROTECTION****POISON****VAPOR**

- i. Open drain cock (10) and drain cleaning solution into drain pan.
9. Close all drain cocks (4, 6, 8) and (10).

WARNING

**CHEMICAL****EYE PROTECTION****POISON****VAPOR**

10. Remove drain pan and dispose of contents in accordance with local procedures.

NOTE

Repeat steps 3 through 10, as necessary, until contaminants are removed.

- 11. Fill cooling system with clean water, through heat exchanger fill neck (3), until water level is 1 in. below fill neck (3).
- 12. Install pressure control cap (2) by pressing down and rotating clockwise.

WARNING

EAR PROTECTION

13. Start engine. (TM 55-1945-205-10-1)

WARNING

EAR PROTECTION

14. After engine reaches normal operating temperature, run engine for five minutes.
15. Shut down engine. (TM 55-1945-205-10-1)
16. Allow engine to cool.
17. Drain cooling system.

WARNING

HOT AREA

Do not remove the pressure control cap from heat exchanger or attempt to drain the coolant until engine has cooled. Sudden release of pressure can result in loss of coolant and possible injury to personnel.

- a. Remove pressure control cap (2) from heat exchanger (3) by pressing down and rotating counterclockwise.
- b. Position drain pan under drain cocks (4) below right and left exhaust manifold elbows (5).

WARNING

CHEMICAL



EYE PROTECTION



POISON



VAPOR

- c. Open two drain cocks (4) at right and left side of engine and drain water into drain pan.
- d. Position drain pan under drain cocks (6) located on right and left side of cylinder block below exhaust manifolds (7).

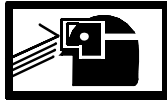
WARNING**CHEMICAL****EYE PROTECTION****POISON****VAPOR**

- e. Open two drain cocks (6) on right and left side of engine and drain water into drain pan.
- f. Position drain pan under drain cock (8) at bottom of oil cooler (9).

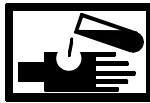
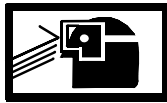
WARNING**CHEMICAL****EYE PROTECTION****POISON****VAPOR**

- g. Open drain cock (8) and drain water into drain pan.
- h. Position drain pan under drain cock (10) below heat exchanger (11).

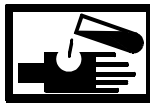
WARNING**CHEMICAL****EYE PROTECTION****POISON****VAPOR**

- i. Open one drain cock (10) and drain water into drain pan.
18. Close drain cocks (4, 6, 8 and 10).
19. Install engine thermostats. (WP 0143 00)
20. Replace fresh water cooling system filter element. (WP 0140 00)

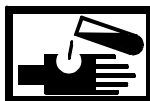
WARNING**CHEMICAL****EYE PROTECTION****POISON****VAPOR**

- 21. Remove drain pans and dispose of contents in accordance with local procedures.

FILL COOLING SYSTEM**WARNING****CHEMICAL****EYE PROTECTION****POISON****VAPOR**

1. Prepare a 50/50 solution of antifreeze and distilled water. (TB 55-1900-207-24)

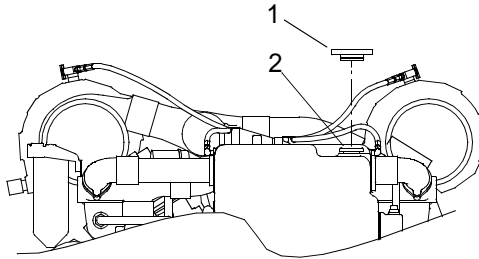
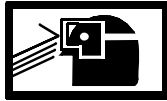
**WARNING****CHEMICAL****EYE PROTECTION****POISON****VAPOR**

2. Add corrosion inhibitor to antifreeze and distilled water solution. (TB 55-1900-207-24)

WARNING**HOT AREA**

Do not remove the pressure control cap from heat exchanger or attempt to drain the coolant until engine has cooled. Sudden release of pressure can result in loss of coolant and possible injury to personnel.

3. Remove pressure control cap (2) from heat exchanger (3) by pressing down and rotating counterclockwise.
4. Ensure drain cocks (4, 6, 8 and 10) are closed.

WARNING**CHEMICAL****EYE PROTECTION****POISON****VAPOR**

5. Add antifreeze and water solution through fill neck (3) until solution level is 1 in. below the fill neck (3).

-
6. Install pressure control cap (2) onto heat exchanger filler neck (3) by pressing down on cap and turning clockwise.

WARNING



EAR PROTECTION

7. Start engine. (TM 55-1945-205-10-1)

WARNING



EAR PROTECTION

8. After engine reaches normal operating temperature, run engine for five minutes.
9. Shut down engine. (TM 55-1945-205-10-1)
10. Service the fresh water cooling system. (TM 55-1945-205-10-1)

WARNING



CHEMICAL

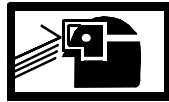

EYE PROTECTION



POISON



VAPOR



SLICK FLOOR

11. Clean up spilled fluid with spill kit and dispose of spill kit waste in accordance with local procedure.
12. Perform operational checks. (TM 55-1945-205-10-1)

END OF WORK PACKAGE

**UNIT LEVEL MAINTENANCE
CAUSEWAY FERRY
FRESH WATER HEAT EXCHANGER
CLEANING**

INITIAL SETUP:**Tools**

Tool Kit, General Mechanic's (Rail and Marine) (Item 131, WP 0188 00)
 Gloves, Chemical (Item 52 WP 0188 00)
 Goggles, Industrial (Item 54, WP 0188 00)
 Apron, Utility (Item 8, WP 0188 00)

Materials/Parts

Cleaner (Item 8, WP 0187 00)
 Rag, Wiping (Item 28, WP 0187 00)

Personnel Required

Engineer 88L

Equipment Condition

Heat Exchanger Cool To Touch.

CLEAN FRESH WATER HEAT EXCHANGER

1. Verify MAIN circuit breaker (1) on the propulsion module circuit breaker panel A6 is off.

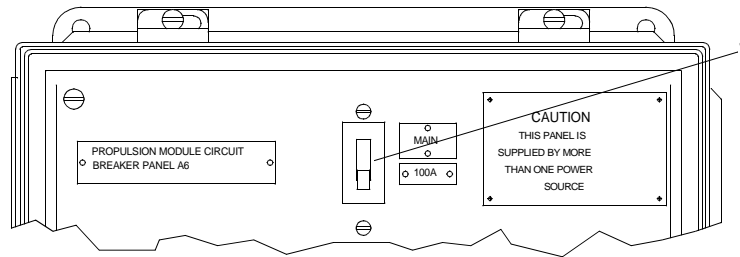

WARNING



CHEMICAL



EYE PROTECTION

2. Using a wiping rag, apply cleaner to the exterior of the heat exchanger (2) on the front of the engine (3).

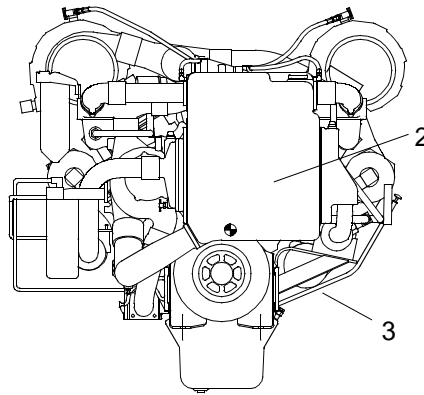
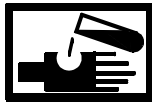
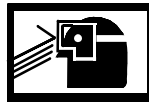
**WARNING****CHEMICAL****EYE PROTECTION**

3. Using a parts cleaning brush, remove hardened debris.
4. Rinse the exterior with clean water.
5. Using a wiping rag, wipe down the exterior of the heat exchanger (2).

END OF WORK PACKAGE

**UNIT LEVEL MAINTENANCE
CAUSEWAY FERRY
FRESH WATER COOLING SYSTEM
PRESSURE TESTING**

INITIAL SETUP:**Test Equipment**

Test Kit, Radiator -R (Item 122, WP 0188 00)

Tools

Tool Kit, General Mechanic's (Rail and Marine) (Item 131, WP 0188 00)

Gloves, Chemical (Item 52, WP 0188 00)

Goggles, Industrial (Item 54, WP 0188 00)

Respirator, Air Filtering (Item 109, WP 0188 00)

Apron, Utility (Item 8, WP 0188 00)

Personnel Required

Engineer 88L

Equipment Condition

Engine Cool To Touch.

PRESSURE TEST FRESH WATER COOLING SYSTEM

WARNING



CHEMICAL



EYE PROTECTION



POISON



VAPOR

NOTE

This test is typical for both the port and starboard engines.

1. Remove the heat exchanger pressure cap (1) from the heat exchanger (2), by pressing down and rotating counterclockwise.

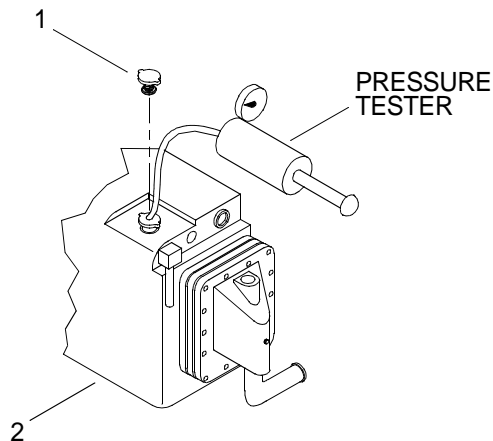

CAUTION

Do not exceed 20 PSI (138 kPa). Failure to comply could result in a rupture in the cooling system or other damage to equipment.

2. Using the radiator test kit, pressurize the cooling system to 15-20 PSI (103-138 kPa).
3. Observe the system pressure on the tester.
4. If a measurable pressure drop is detected, examine the entire cooling system for a possible external or internal leak. Repair if necessary.
5. Release pressure.
6. Remove tester from heat exchanger.
7. Install the pressure cap adaptor to the pressure tester.

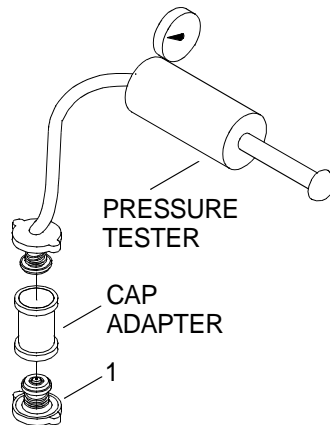

8. Install the pressure cap (1) on the cap adaptor.
9. Apply 15-20 PSI (103-138 kPa) pressure to the pressure cap (1) and hold for 10 minutes.

NOTE

If the cap releases early or late, the cap must be replaced.

10. Observe the cap release pressure at 15 PSI (130 kPa).
11. Remove pressure tester and cap adaptor from cap (1).
12. Install heat exchanger pressure cap (1) on heat exchanger (2), by pressing down and rotating clockwise.

END OF WORK PACKAGE

**DIRECT SUPPORT MAINTENANCE
CAUSEWAY FERRY
FRESH WATER COOLING SYSTEM HEAT EXCHANGER
REMOVAL, CLEANING, INSPECTION AND INSTALLATION**

INITIAL SETUP:**Tools**

Tool Kit, General Mechanic's (Rail and Marine) (Item 131, WP 0188 00)
Brush, Wire, Scratch (Item 21, WP 0188 00)
Gloves, Chemical (Item 52, WP 0188 00)
Goggles, Industrial (Item 54, WP 0188 00)
Respirator, Air Filtering (Item 109, WP 0188 00)
Apron, Utility (Item 8, WP 0188 00)

Materials/Parts

Core, Heat Exchanger
(72582)
NSN *Not Available*
PN 23500957
Qty 1
Gasket
(72582)
NSN 5330-00-759-9776
PN 5117406
Qty 3
O Ring
(72582)
NSN 5331-00-291-9215
PN 5167746
Qty 4
Retaining, Packing
(72582)
NSN 5330-00-499-3553
PN
Qty 2
Anode, Corrosion Preventive
(72582)
NSN 5342-00-278-1224
PN 8515851
Qty 2
Cleaning Compound (Item 10, WP 0187 00)

Personnel Required

Engineer 88L

References

TM 55-1945-205-10-1

Equipment Condition

Engine Cool To Touch.
Fresh Water Cooling System Drained. (WP 0134 00)

REMOVE FRESH WATER COOLING SYSTEM HEAT EXCHANGER

NOTE

Allow engine to cool before draining coolant.

This procedure is the same for both the starboard and port engines.

1. Close butterfly (sea chest) valve (1).

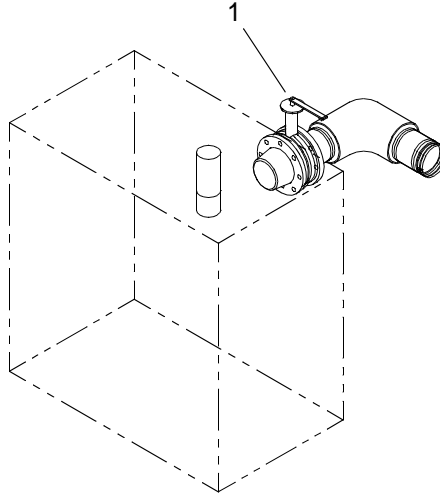

2. Loosen clamp (2) on inlet hose/tube assembly (3).

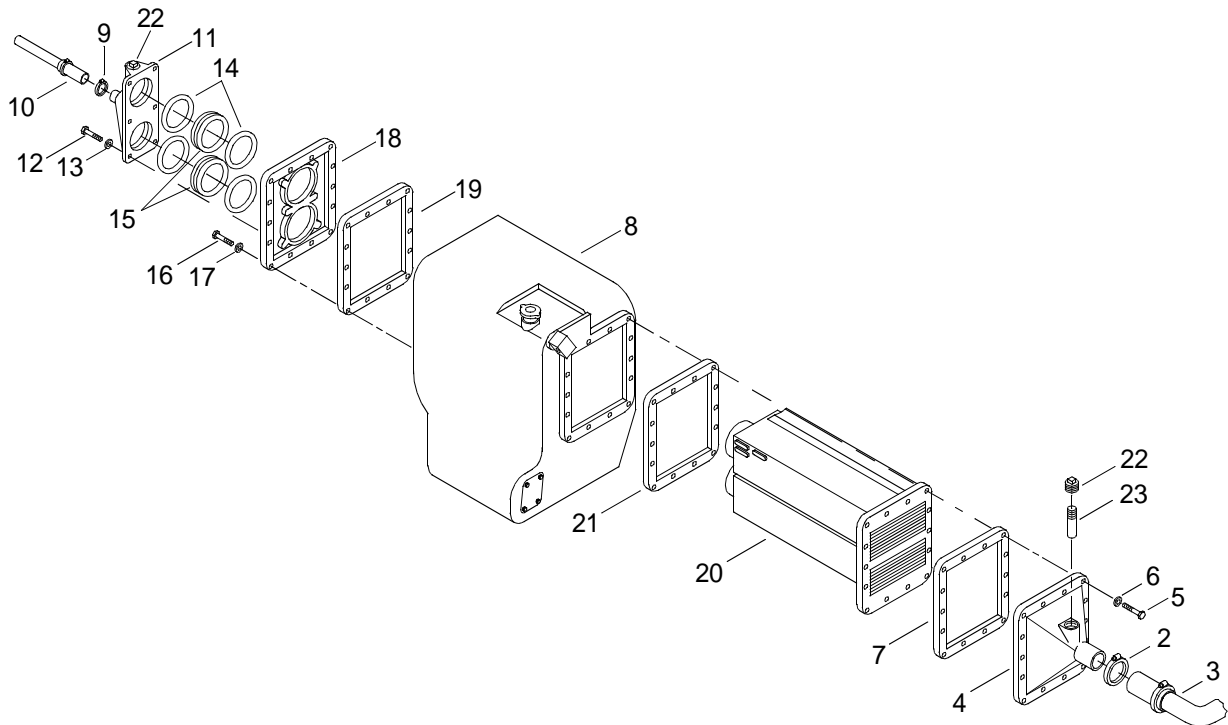

3. Remove inlet hose/tube assembly (3) and clamp (2) from heat exchanger inlet cover (4).
4. Remove 14 bolts (5) and lock washers (6) from heat exchanger inlet cover (4).
5. Remove heat exchanger inlet cover (4) and gasket (7) from expansion tank (8). Discard gasket.

6. Loosen hose clamps (9) on outlet hose/tube assembly (10).
7. Remove outlet hose/tube assembly (10) and clamp (9) from outlet flange (11).
8. Remove six bolts (12) and lock washers (13) from outlet flange (11).
9. Remove outlet flange (11) containing the o-rings (14) and packing retainers (15) from expansion tank (8).
10. Remove and discard o-rings (14) and packing retainers (15).
11. Remove 14 bolts (16) and lock washers (17) from outlet cover (18).
12. Remove outlet cover (18) and gasket (19) from expansion tank (8). Discard gasket.
13. Remove heat exchanger core (20) and gasket (21). Discard gasket.

CLEAN HEAT EXCHANGER CORE

WARNING

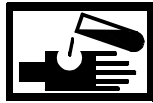

CHEMICAL

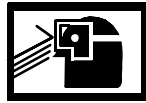

EYE PROTECTION



VAPOR

NOTE

To prevent drying and hardening of accumulated foreign substances, the heat exchanger core must be cleaned as soon as possible after removing it from service.

1. Immerse heat exchanger core (20) into cleaning compound.

WARNING



CHEMICAL



EYE PROTECTION



VAPOR

2. Remove core (20) from cleaning compound when foaming and bubbling stops.

WARNING



CHEMICAL



EYE PROTECTION



VAPOR

3. Flush core (20) thoroughly with clean, hot water under pressure.

INSPECT ZINC ELECTRODES

1. Remove two plugs (22) and electrodes (23) from heat exchanger inlet cover (4) and outlet flange (11).

NOTE

To determine the condition of a used electrode, strike it sharply against a hard surface. A weakened electrode will break.

2. Clean electrodes (23) with a wire brush or, if worn excessively, replace with new electrodes.

INSTALL HEAT EXCHANGER

1. Install new gasket (21) on new heat exchanger (20).
2. Position new heat exchanger core (20) with gasket (21) in expansion tank (8).
3. Install new gasket (19) and outlet cover (18) on expansion tank (8).
4. Install 14 bolts (16) with washers (17).
5. Install two new seals (14), two new seal gland (15) then two new seals (14) into outlet flange (11).
6. Install outlet flange (11) on outlet cover (18).
7. Secure outlet flange (11) with six bolts (12) and lock washers (13).
8. Install outlet hose/tube assembly (10) with clamp (9) to outlet flange (11).
9. Install new gasket (7) on heat exchanger inlet cover (4).
10. Position heat exchanger inlet cover (4) with new gasket (7) on expansion tank (8).
11. Install the raw water inlet hose/tube assembly (3) with hose clamp (2) on heat exchanger inlet cover (4).
12. Tighten hose clamps (2).
13. Service fresh water coolant system. (WP 0133 00).
14. Check cooling system for leaks.
15. Perform operational check of diesel engine. (TM 55-1945-205-10-1)

END OF WORK PACKAGE

**DIRECT SUPPORT MAINTENANCE
CAUSEWAY FERRY
FRESH WATER COOLING SYSTEM HEAT EXCHANGER
REMOVAL AND INSTALLATION**

INITIAL SETUP:**Tools**

Tool Kit, General Mechanic's (Item 130, WP 0188 00)
Gloves, Chemical (Item 52, WP 0188 00)
Goggles, Industrial (Safety) (Item 54, WP 0188 00)
Apron, Utility (Item 8, WP 0188 00)
Respirator, Air Filtering (Item 109, WP 0188 00)
Sling, 5300 lb, 6 ft Long (Item 118, WP 0188 00)
Qty 2
Shackle, ½ in., 2 Ton (Item 115, WP 0188 00)
Wrench, Pipe, 5120-00-277-1462 (Item 136, WP 0188 00)

Materials/Parts

Tank, Heat Exchanger
(72582)
PN 23505752
Gasket, Raw Water Inlet
(72582)
PN 5117406
Gasket, Coolant Outlet
(72582)
PN 23501104

Personnel Required

Engineer 88L

References

TM 55-1945-205-10-1

Equipment Condition

Engine Cool To Touch.
SINGARS Antenna Removed. (TM 11-5820-890-10-8)
Main Navigation Mast Removed. (TM 55-1945-205-24-1-1)
Powered Section Intake Plenum Or Operators Cab Removed. (TM 55-1945-205-24-1-1)
Powered Section Engine Hatch Removed. (TM 55-1945-205-24-1-1)
Alternator Belt Guard Removed. (TM 55-1945-205-24-1-1)
Fresh Water Cooling System Drained. (WP 0134 00)

REMOVE FRESH WATER COOLING SYSTEM HEAT EXCHANGER**NOTE**

This procedure is typical for both the starboard and port engines.

1. Verify butterfly (sea chest) valve (1) is closed.

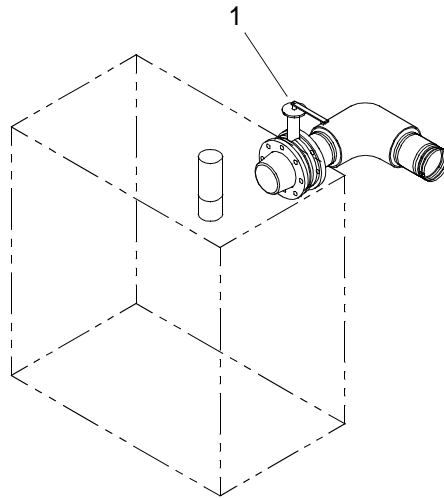

5C183-10

- Remove cap screws (2) and lock washers (3) from the raw water inlet tube cover (4).

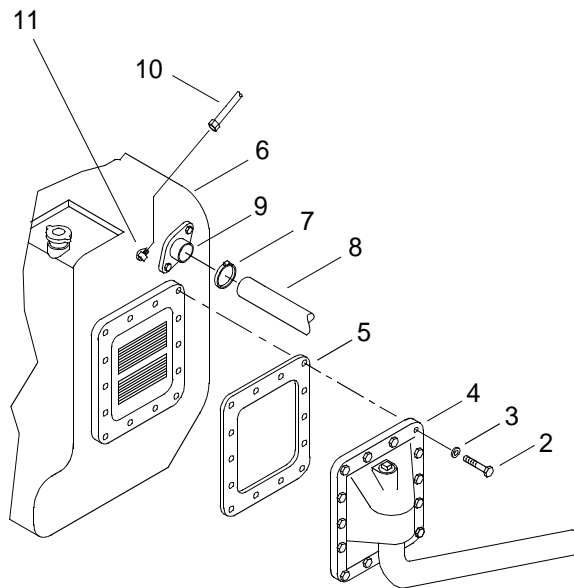

- Remove the inlet tube cover (4) and gasket (5) from expansion tank (6). Discard gasket.

WARNING



CHEMICAL

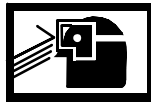

EYE PROTECTION



VAPOR



POISON

- Remove clamps (7) and hose (8) from the inlet coolant flange (9).
- Remove port turbocharger coolant hose (10) from elbow fitting (11).

- Remove starboard turbocharger coolant hose (12) from elbow fitting (13).

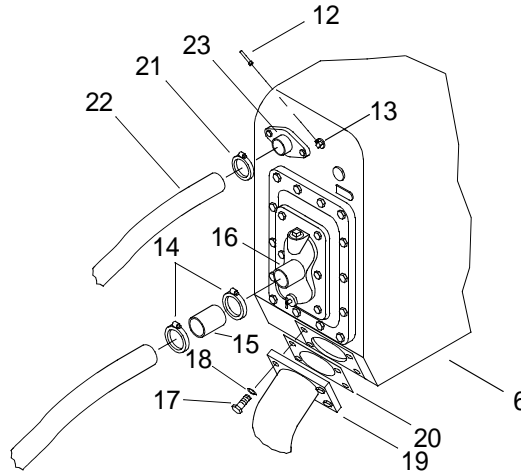

- Remove clamps (14) from raw water outlet hose (15) on right (starboard) of heat exchanger expansion tank (6).
- Remove hose (15) from raw water outlet tube (16).

WARNING



CHEMICAL



EYE PROTECTION



VAPOR



POISON

- Remove cap screws (17) and lock washers (18) from coolant outlet flange (19).

WARNING

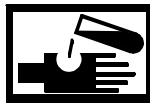

CHEMICAL

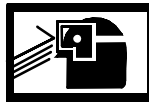

EYE PROTECTION



VAPOR



POISON

- Remove coolant outlet flange (19) and gasket (20) from expansion tank (6). Discard gasket.

WARNING

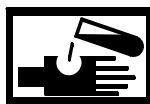

CHEMICAL



EYE PROTECTION



VAPOR



POISON

- Remove the clamp (21) and hose (22) from the right (starboard) side coolant inlet flange (23).

12. Remove nut (24) and bolt (25) securing fire suppression trip mechanism solenoid (26) to its mount, located above the engine.

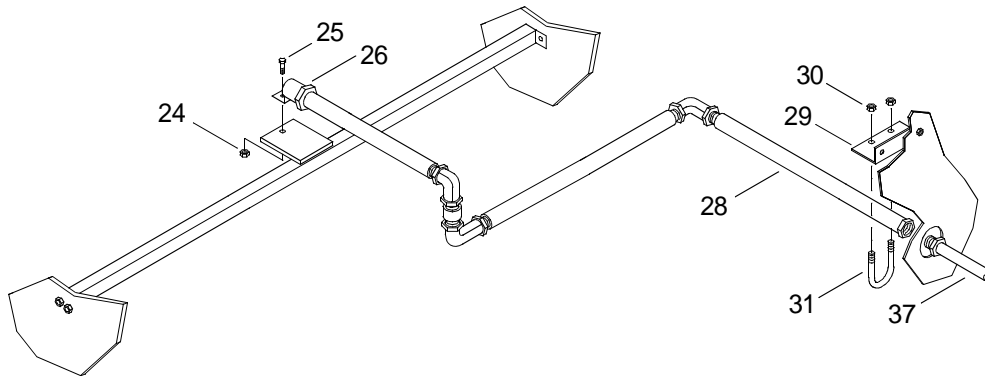

13. Using a pipe wrench, disconnect the pipe coupling (27) for the fire suppression CO2 supply line (28) that feeds the trip mechanism solenoid (26) near the propulsion module frame cross-member support bracket (29).
14. Remove the two nuts (30) and U-joint bolt (31) supporting the CO2 line (28) to the propulsion module frame cross-member support bracket (29).
15. Remove the CO2 line (28) with attached trip mechanism solenoid (26).

WARNING



HEAVY PARTS

16. Using two slings, shackle and crane, support the heat exchanger.
17. Remove bolts (30) and lock washers (31) that secure heat exchanger tank (6) to mounting bracket (32).

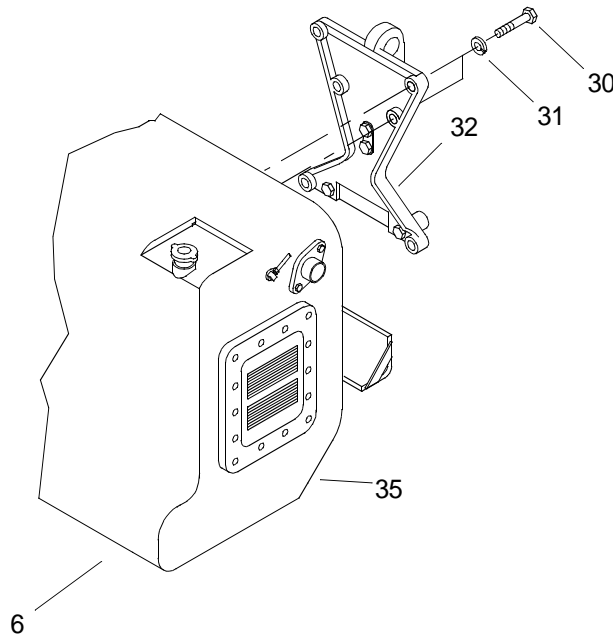

18. Remove bolts (33) and lock washers (34) that secure heat exchanger tank (6) to bottom mounting bracket (35).

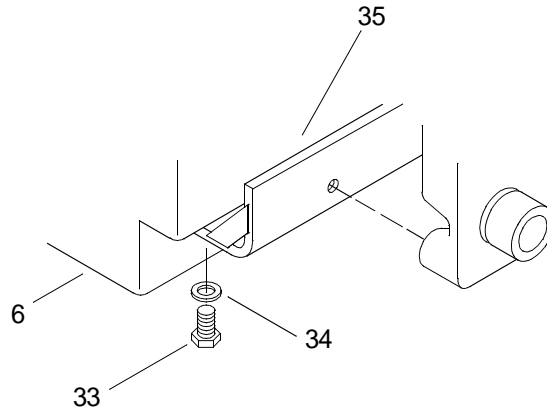

WARNING



HEAVY PARTS

19. Remove heat exchanger tank (6) from engine.
 20. Remove the shackle and slings from the heat exchanger.

INSTALL FRESH WATER COOLING SYSTEM HEAT EXCHANGER

WARNING



HEAVY PARTS

1. Using two slings, shackle and crane, position heat exchanger tank (6) on bottom bracket (35) and align bolt holes.

WARNING



HEAVY PARTS

2. Install bolts (33) and lock washers (34) to secure heat exchanger tank (6) to bottom mounting bracket (35). Finger tighten only to allow alignment of upper bolt holes.

3. Install bolts (30) and lock washers (31) in upper bolt holes of heat exchanger tank (6) and mounting bracket (32).

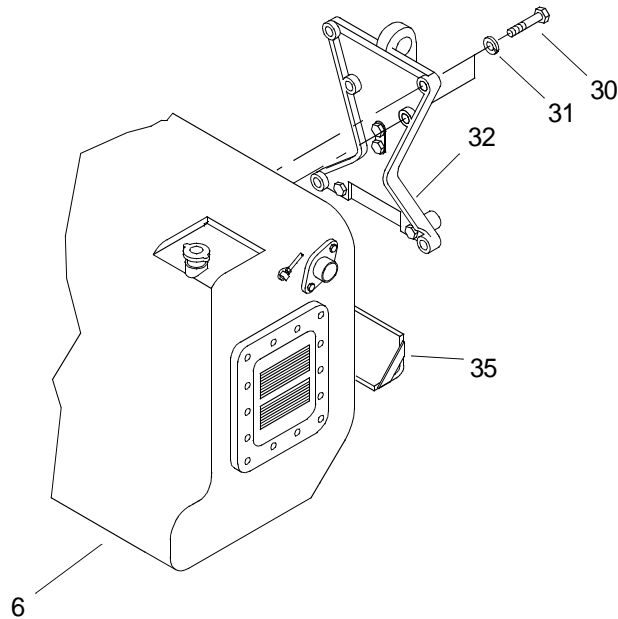

4. Tighten upper and lower bolts (30 and 33) until lock washers (31 and 34) are fully compressed.
5. Remove shackle and slings from heat exchanger.
6. Check all hoses for softness and cracks before installation. Replace damaged hoses, if necessary.
7. Install the CO2 line (28) with attached trip mechanism solenoid (26).

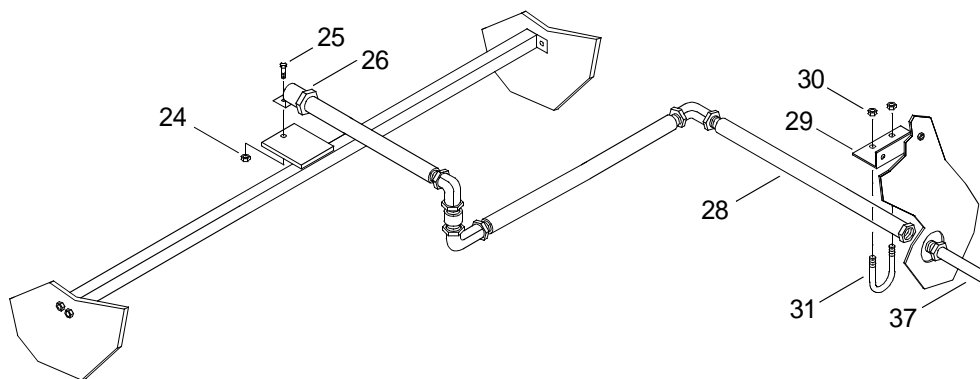

8. Install the two nuts (30) and U-bolt (31) supporting the CO2 line (28) to the propulsion module frame cross-member support bracket (29).
9. Using a pipe wrench, connect the pipe coupling (27) for the fire suppression CO2 supply line (28) that feeds the trip mechanism solenoid (26) near the propulsion module frame cross-member support bracket (29).
10. Remove nut (24) and bolt (25) securing fire suppression trip mechanism solenoid (26) to its mount, located above the engine.
11. Install hose clamp (21) and hose (22) to right (starboard) side inlet coolant flange (23).
12. Tighten hose clamp (21).

13. Position coolant outlet flange (19) and new gasket (20) onto expansion tank (6).

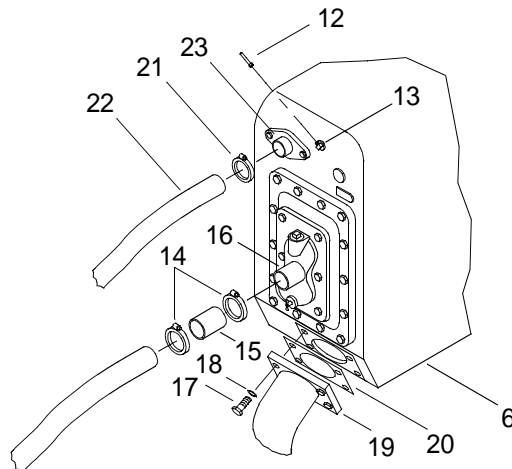

14. Install cap screws (17) and lock washers (18) in coolant outlet flange (19).

15. Install hose (15) and clamps (14) on to raw water outlet tube (16).

16. Tighten hose clamps (14).

17. Install starboard turbocharger coolant hose (12) on elbow fitting (13).

18. Install port turbocharger coolant hose (10) on elbow fitting (11).

19. Install the hose (8) and clamp (7) on the left (port) side inlet coolant flange (9).

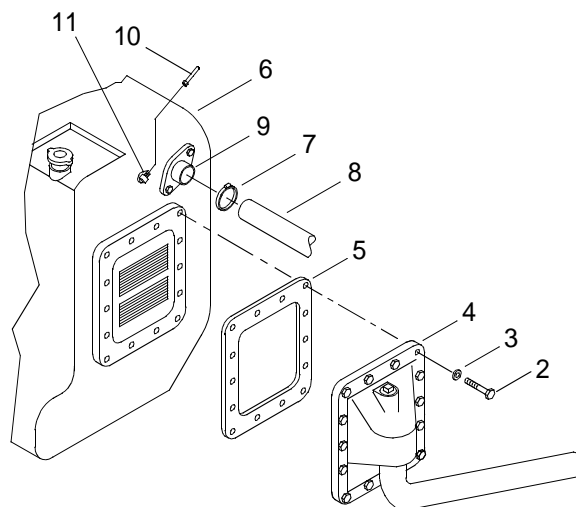

20. Tighten hose clamp (7).

21. Position the inlet tube cover (4) and new gasket (5) on the expansion tank (6).

22. Install cap screws (2) and lock washers (3) to secure raw water inlet cover (4) to expansion tank (6).

23. Service fresh water cooling system. (WP 0133 00)

24. Install alternator belt guard. (TM 55-1945-205-24-1-1)

25. Install powered section engine hatch. (TM 55-1945-205-24-1-1)
26. Install powered section intake plenum or operators cab. (TM 55-1945-205-24-1-1)
27. Install main navigation mast. (TM 55-1945-205-24-1-1)
28. Install SINGARS antenna. (TM 11-5820-890-10-8)
29. Start engine to activate bilge pumps. (TM 55-1945-205-10-1)
30. Shut down engine. (TM 55-1945-205-10-1)
31. Perform operational check of diesel engine. (TM 55-1945-205-10-1)

END OF WORK PACKAGE

**DIRECT SUPPORT MAINTENANCE
WARPING TUG
FORWARD LIFTING BRACKET
REPLACEMENT**

INITIAL SETUP:**Tools**

Tool Kit, General Mechanic's (Item 130, WP 0188 00)

Materials/Parts

Support
(72582)
PN 23501783

Personnel Required

Engineer 88L

References

TM 55-1945-205-10-1

Equipment Condition

Main Navigation Mast Removed. (TM 55-1945-205-24-1-1)
SINGARS Antenna Removed. (TM 11-5820-890-10-8)
Powered Section Operators Cab Removed. (TM 55-1945-205-24-1-1)
Powered Section Intake Plenum Assembly Removed. (TM 55-1945-205-24-1-1)
Powered Section Exhaust Plenum Removed. (TM 55-1945-205-24-1-1)
Cooling System Drained. (WP 0134 00)
Engine Cool To Touch.
Heat Exchanger Removed. (WP 0138 00)

REMOVE FORWARD LIFTING BRACKET

1. Remove two bolts (1) and lock washers (2) securing bracket (3) to support (4).

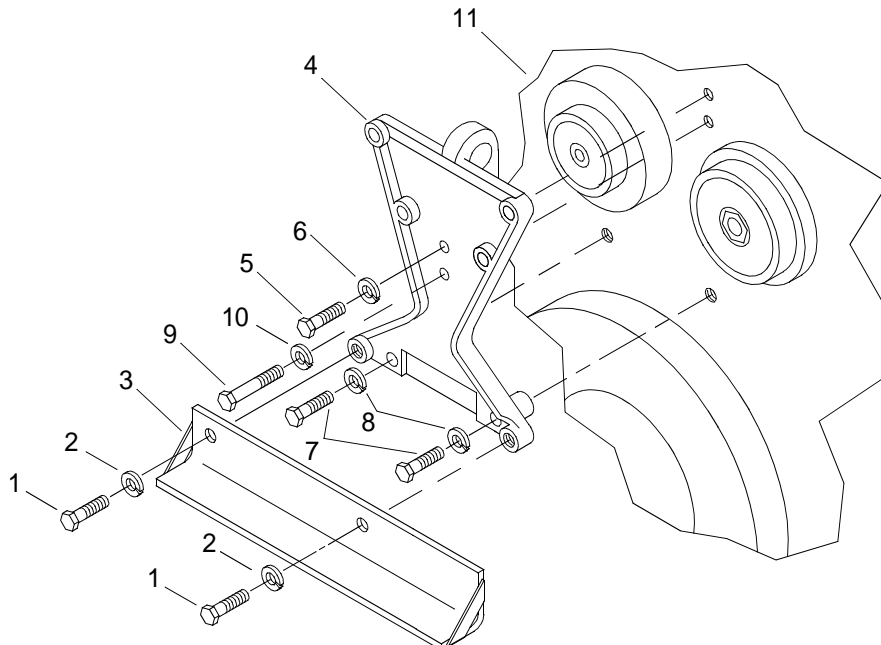

2. Remove cap screw (5) and lock washer (6) from support (4).
3. Remove two cap screws (7) and lock washers (8) from support (4).
4. Remove cap screw (9) and lock washer (10) from support (4).
5. Remove support (4) from engine (11) and discard.

INSTALL FORWARD LIFTING BRACKET

1. Position new support (4) on engine (11).
2. Install cap screw (9) and lock washer (10) on support (4).
3. Install two cap screws (7) and lock washers (8) on support (4).
4. Install cap screw (5) and lock washer (6) on support (4).
5. Position bracket (3) on support (4).
6. Install two bolts (1) and lock washers (2) securing bracket (3) to support (4).
7. Install heat exchanger. (WP 0138 00)
8. Service cooling system. (WP 0133 00)
9. Install engine deck hatch. (TM 55-1945-205-24-1-1)
10. Install powered section operators cab. (TM 55-1945-205-24-1-1)
11. Install SINGARS antenna. (TM 11-5820-890-10-8)
12. Install powered section intake plenum assembly. (TM 55-1945-205-24-1-1)
13. Install main navigation mast. (TM 55-1945-205-24-1-1)
14. Perform operational checks. (TM 55-1945-205-10-1)

END OF WORK PACKAGE

**UNIT LEVEL MAINTENANCE
CAUSEWAY FERRY
FRESH WATER COOLING SYSTEM FILTER ELEMENT
REPLACEMENT**

INITIAL SETUP:**Tools**

Tool Kit, General Mechanic's (Rail and Marine) (Item 131 WP, WP 0188 00)
Gloves, Chemical (Item 52, WP 0188 00)
Goggles (Item 54, WP 0188 00)
Respirator, Air Filtering (Item 109, WP 0188 00)
Apron, Utility (Item 8, WP 0188 00)

Materials/Parts

Filter Element, Fluid
(72852)
NSN 2941-014-76-7381
PN 23508427

Personnel Required

Engineer 88L

References

TM 55-1945-205-10-1

Equipment Condition

Engine Cool To Touch.

REMOVE FRESH WATER COOLING SYSTEM FILTER ELEMENT

1. Verify MAIN circuit breaker (1) on the propulsion module circuit breaker panel A6 is off.

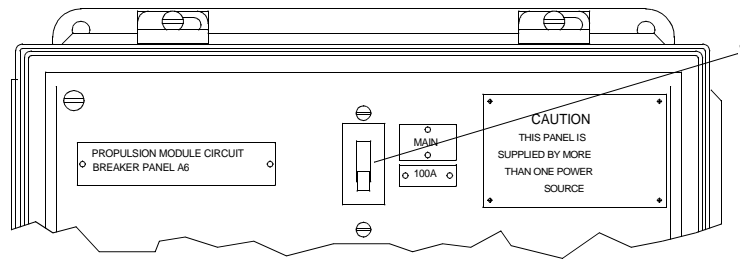

2. Close fresh water filter hand valves (2).

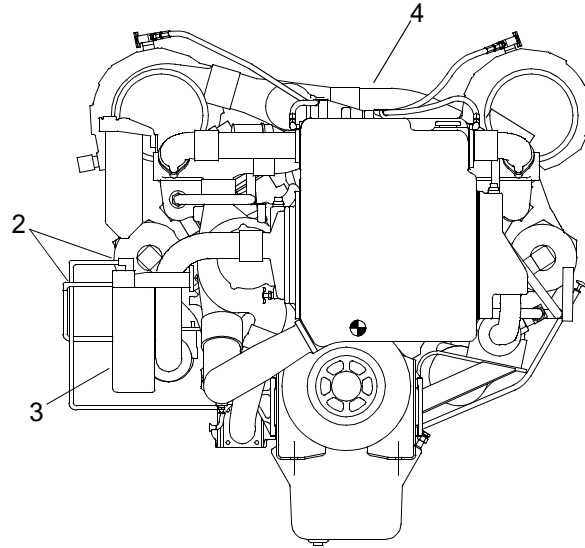

WARNING



CHEMICAL

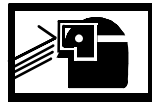

EYE PROTECTION

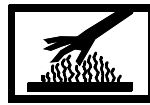

HOT AREA



VAPOR

3. Turn the fresh water filter (3) counterclockwise and remove from the engine (4).

INSTALL FRESH WATER COOLING SYSTEM FILTER ELEMENT

1. Install a new fresh water filter (3) by turning clockwise onto the engine (4).
2. Open the fresh water filter hand valves (2).
3. Service cooling system. (WP 0133 00)
4. Perform operational check of diesel engine. (TM 55-1945-205-10-1)

END OF WORK PACKAGE

**UNIT LEVEL MAINTENANCE
CAUSEWAY FERRY
FRESH WATER COOLING SYSTEM FILTER HEAD COVER
REPLACEMENT**

INITIAL SETUP:**Tools**

Tool Kit, General Mechanic's (Rail and Marine) (Item 131, WP 0188 00)
 Pan, Drain (Item 87, WP 0188 00)
 Gloves, Chemical (Item 52, WP 0188 00)
 Goggles, Industrial (Item 54, WP 0188 00)
 Apron, Utility (Item 8, WP 0188 00)
 Respirator, Air Filtering (Item 109, WP 0188 00)

Materials/Parts

Cover
 (72582)
 PN 681956
 Spill Clean-up Kit, Hazardous Material (Item 32, WP 0187 00)
 Tape, Antiseize (Item 34, WP 0187 00)

Personnel Required

Engineer 88L

References

TM 55-1945-205-10-1

Equipment Condition

Fresh Water Cooling System Filter Removed. (WP 0140 00)

REMOVE FRESH WATER COOLING SYSTEM FILTER HEAD COVER

1. Place drain pan under filter cover (1).

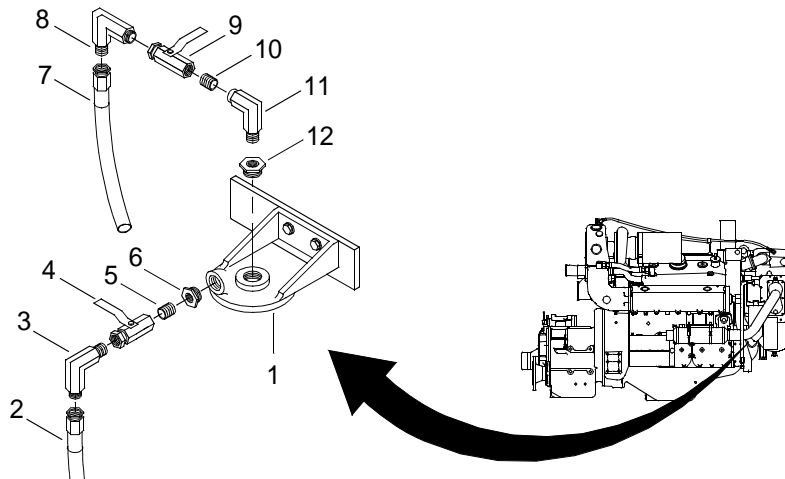

WARNING**CHEMICAL****EYE PROTECTION****VAPOR****POISON**

2. Remove hose (2) from elbow (3), allowing coolant to drain into drain pan.
3. Remove elbow (3), shutoff valve (4), nipple (5) and bushing (6) from filter cover (1).

WARNING**CHEMICAL****EYE PROTECTION****VAPOR****POISON**

4. Remove hose (7) from elbow (8), allowing coolant to drain into drain pan.
5. Remove elbow (8) from shutoff valve (9).
6. Remove shutoff valve (9) from nipple (10).
7. Remove nipple (10) and elbow (11) from bushing (12).
8. Remove bushing (12) from filter head (1).
9. Remove three hex nuts (13) and lock washers (14) from cap screws (15).

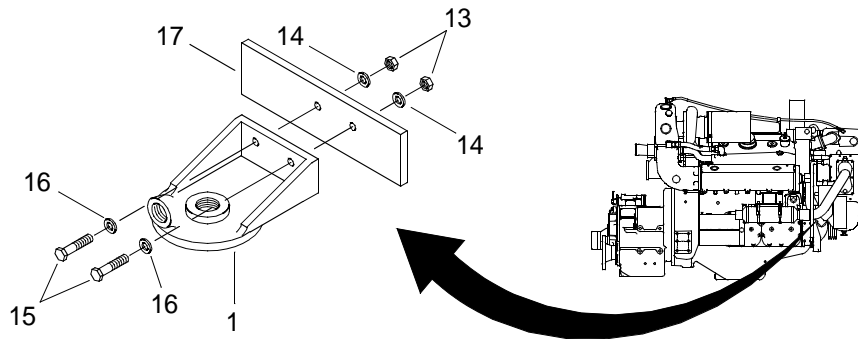

10. Remove three cap screws (15) and flat washers (16) from filter cover (1).
11. Remove filter cover (1) from bracket (17) and discard.

WARNING



CHEMICAL



EYE PROTECTION



VAPOR



POISON

12. Remove drain pan and dispose of its contents in accordance with local procedure.

INSTALL FRESH WATER COOLING SYSTEM FILTER HEAD COVER

1. Position new filter cover (1) on bracket (17).

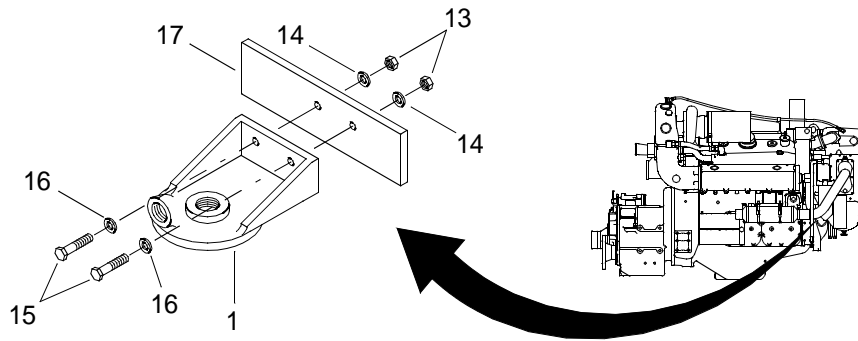

2. Install three cap screws (15) and flat washers (16) on filter cover (1).

3. Install three hex nuts (13) and lock washers (14) on cap screws (15).

WARNING



CHEMICAL

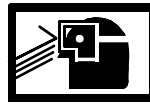

EYE PROTECTION

4. Wrap bushing (12) threads with antiseize tape.

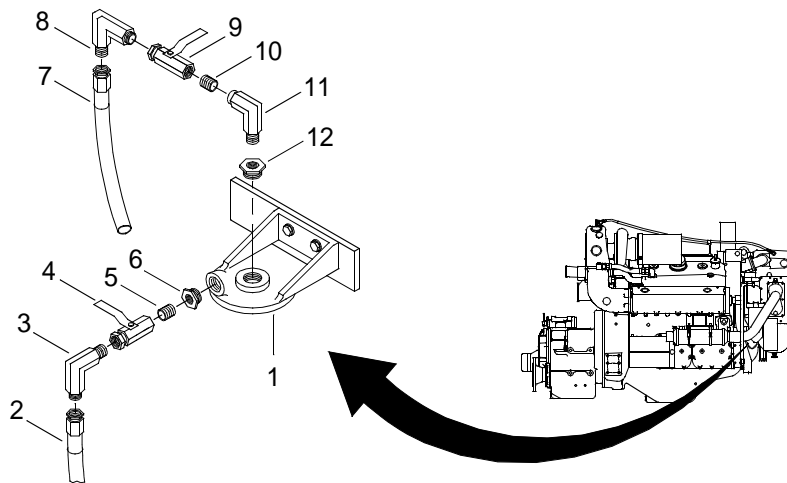

-
5. Install bushing (12) on filter cover (1).
 6. Wrap elbow (11) threads with antiseize tape.
 7. Install nipple (10) and elbow (11) on bushing (12).
 8. Wrap nipple (10) threads with antiseize tape.
 9. Install shutoff valve (9) on nipple (10).
 10. Wrap both end of elbow (8) threads with antiseize tape.
 11. Install elbow (8) on shutoff valve (9).
 12. Install hose (7) on elbow (8).
 13. Wrap bushing (6) threads with antiseize tape.
 14. Install elbow (3), shutoff valve (4), nipple (5) and bushing (6) on filter cover (1).
 15. Wrap elbow (3) threads with antiseize tape.
 16. Install hose (2) on elbow (3).
 17. Install fresh water cooling system filter element. (WP 0140 00)
 18. Start engine. (TM 55-1945-205-10-1)
 19. Check coolant filter head for leaks.
 20. Shut engine down. (TM 55-1945-205-10-1)
 21. Service cooling system. (WP 0133 00)

WARNING

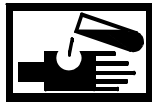
**CHEMICAL****EYE PROTECTION****VAPOR****POISON**

22. Clean up spilled fluid with spill kit and dispose of spill kit waste in accordance with local procedure.

END OF WORK PACKAGE

**UNIT LEVEL MAINTENANCE
CAUSEWAY FERRY
FRESH WATER COOLING SYSTEM FILTER HEAD COVER
MOUNTING BRACKET
REPLACEMENT**

INITIAL SETUP:**Tools**

Tool Kit, General Mechanic's (Rail and Marine) (Item 131, WP 0188 00)

Materials/Parts

Bracket
(72582)
PN 1SD31815

Personnel Required

Engineer 88L

References

TM 55-1945-205-10-1

Equipment Condition

Fresh Water Cooling System Filter Element Removed. (WP 0140 00)

Fresh Water Cooling System Filter Head Cover Removed. (WP 0141 00)

REMOVE FRESH WATER COOLING SYSTEM FILTER HEAD COVER MOUNTING BRACKET

1. Verify butterfly valve (1) on sea chest is off.

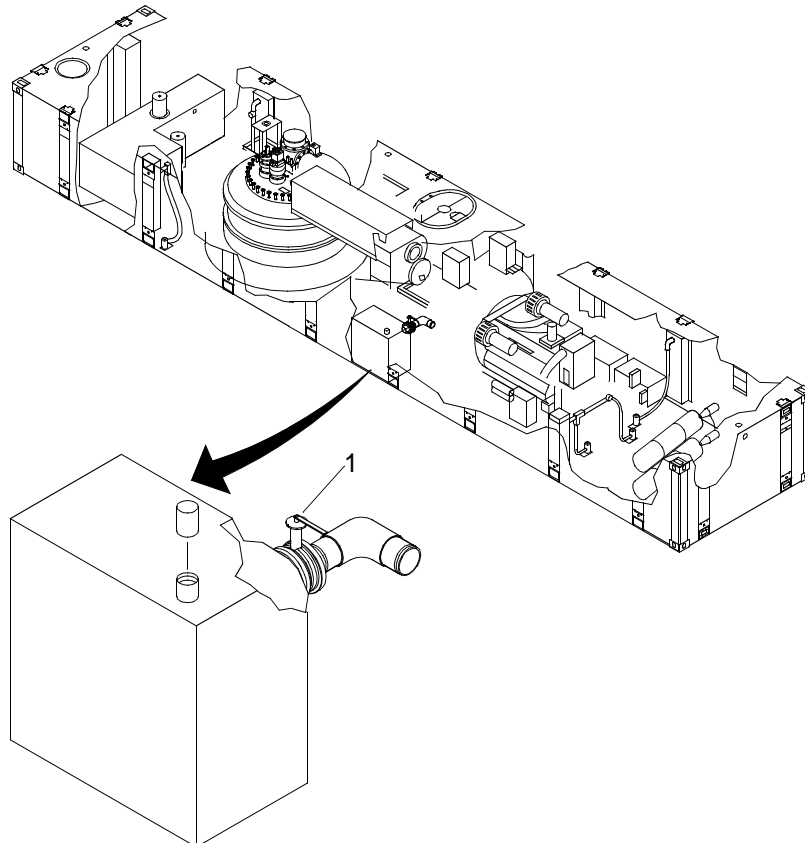

- Remove hose clamps (2) from pipe (3).

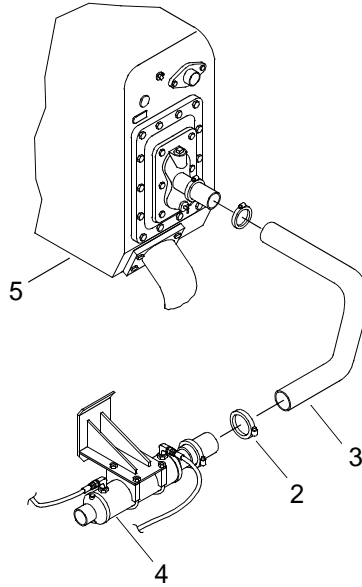

- Remove raw water pipe (3) from between marine gear oil cooler (4) and heat exchanger (5).
- Remove two cap screws (6) and lock washers (7) securing mounting bracket (8) to water pump (9).

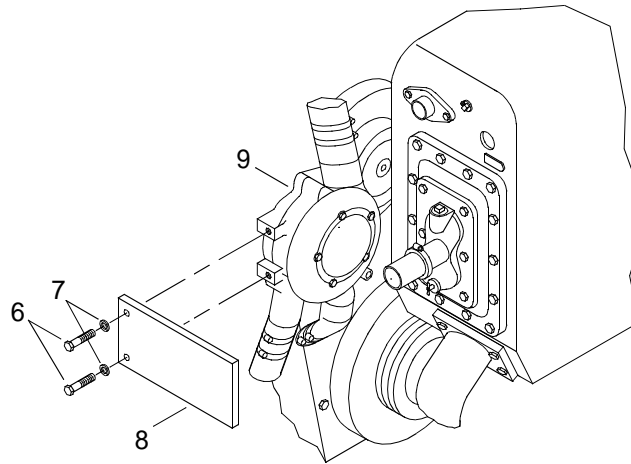

- Discard mounting bracket (8).

INSTALL FRESH WATER COOLING SYSTEM FILTER HEAD COVER MOUNTING BRACKET

- Position new mounting bracket (8) on water pump (9).
- Install two cap screws (6) and lock washers (5) securing mounting bracket (8) to water pump (9).
- Tighten cap screws (8).

4. Install raw water pipe (3) between marine gear oil cooler (4) and heat exchanger (5).

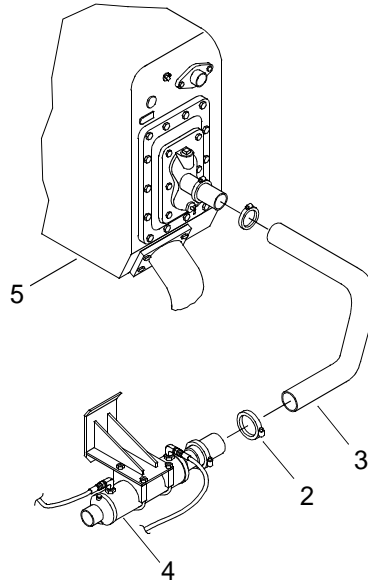

5. Install hose clamps (2) on pipe (3).
6. Tighten hose clamps (2).
7. Install fresh water cooling system filter head cover. (WP 0141 00)
8. Install fresh water cooling system filter element. (WP 0140 00)
9. Perform operational check of diesel engine. (TM 55-1945-205-10-1)

END OF WORK PACKAGE

**UNIT LEVEL MAINTENANCE
CAUSEWAY FERRY
FRESH WATER COOLING SYSTEM THERMOSTAT
REPLACEMENT**

INITIAL SETUP:**Tools**

Tool Kit, General Mechanic's (Rail and Marine) (Item 131, WP 0188 00)
 Wrench, Torque (150-750 in. lbs) (Item 142, WP 0188 00)
 Wrench Set, Socket (3/8 in. sqdr.) (Item 135, WP 0188 00)
 Goggles, Industrial (Item 54, WP 0188 00)
 Respirator, Air Filtering (Item 109, WP 0188 00)
 Gloves, Chemical (Item 52, WP 0188 00)
 Pan, Drain (Item 87, WP 0188 00)

Materials/Parts

Thermostat, Flow Control
 (72582)
 NSN 6620-00-846-9848
 PN 5104832
 Qty 4
 Seal, Plain Encased
 (58312)
 NSN 5330-00-246-6380
 PN 3S9643-00
 Qty 4
 Gasket
 (72582)
 PN 5175989
 Qty 2
 Spill Clean-up Kit, Hazardous Material (Item 32, WP 0187 00)

Personnel Required

Engineer 88L

References

TM 55-1945-205-10-1

Equipment Condition

Main Navigation Mast Removed. (TM 55-1945-205-24-1-1)
 SINCGARS Antenna Removed. (TM 11-5820-890-10-8)
 Powered Section Operators Cab Removed. (TM 55-1945-205-24-1-1)
 Powered Section Intake Plenum Assembly Removed. (TM 55-1945-205-24-1-1)
 Powered Section Exhaust Plenum Removed. (TM 55-1945-205-24-1-1)
 Engine Deck Hatch Removed. (TM 55-1945-205-24-1-1)
 Fresh Water Cooling System Drained. (WP 0134 00)
 Electrical System Engine Normal Stop Push Button Removed. (WP 0165 00)
 Electrical System Engine Normal Stop Push Button Mounting Bracket Removed. (WP 0166 00)
 Auto Shutdown System Fuel Oil Pressure Switch Removed. (WP 0179 00)
 Cold Start Temperature Switch Removed. (WP 0172 00)
 Fuel System Block Removed. (WP 0085 00)
 Fresh Water Cooling System Bypass Tube Removed. (WP 0148 00)

REMOVE FRESH WATER COOLING SYSTEM THERMOSTAT

WARNING



CHEMICAL

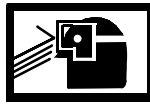

EYE PROTECTION



POISON



VAPOR

NOTE

This task is typical for both port and starboard engines.

1. Remove port thermostats (1).

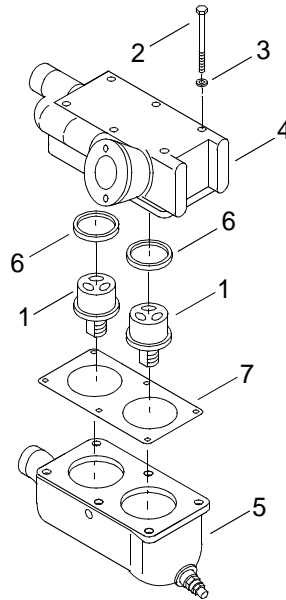

- a. Position a drain pan under thermostats (1).

WARNING



CHEMICAL



EYE PROTECTION



POISON

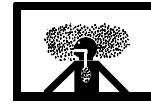

VAPOR

- b. Remove six cap screws (2) and lock washers (3) from the port bank thermostat housing cover (4).

WARNING

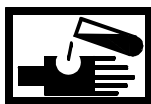

CHEMICAL



EYE PROTECTION



POISON



VAPOR

- c. Remove left bank thermostat housing cover (4) from the port bank thermostat housing (5).
- d. Remove two thermostats (1) from thermostat housing cover (4) and discard.

- e. Remove seals (6) from thermostat housing cover (4) and discard.
- f. Remove gasket (7) from thermostat housing (5) and discard.

WARNING



CHEMICAL



EYE PROTECTION



POISON



VAPOR

- g. Remove drain pan and dispose of its contents in accordance with local procedures.

WARNING



CHEMICAL



EYE PROTECTION



POISON



VAPOR

- 2. Remove starboard thermostats (8).

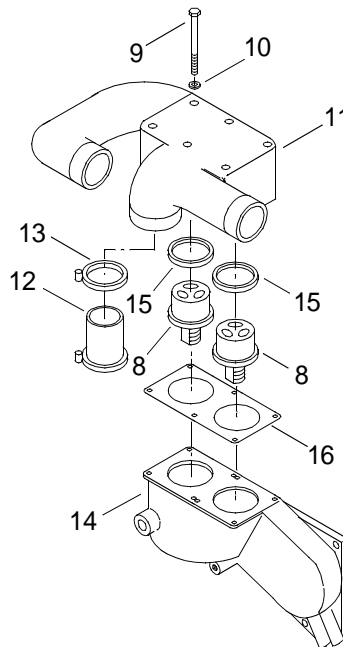

- a. Place a drain pan under thermostats (8).

WARNING

CHEMICAL

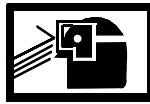

EYE PROTECTION



POISON



VAPOR

- b. Remove six cap screws (9) and lock washers (10) from the starboard bank thermostat housing cover (11).

WARNING

CHEMICAL



EYE PROTECTION



POISON



VAPOR

- c. Disconnect water pump hose (12) from the starboard bank thermostat cover (11).

WARNING

CHEMICAL



EYE PROTECTION



POISON



VAPOR

- {1} Loosen clamp (13).

WARNING

CHEMICAL



EYE PROTECTION



POISON



VAPOR

- {2} Slide clamp (13) off the starboard bank thermostat housing cover (11) down water pump hose (12).

WARNING

CHEMICAL



EYE PROTECTION



POISON



VAPOR

- {3} Remove water pump hose (12).

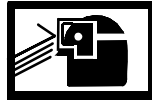
WARNING**CHEMICAL****EYE PROTECTION****POISON****VAPOR**

- d. Remove starboard bank thermostat housing cover (11) from the starboard bank thermostat housing (14).
- e. Remove thermostats (8) from thermostat housing cover (11) and discard.
- f. Remove seal (15) thermostat housing cover (11) and discard.
- g. Remove gasket (16) from thermostat housing (9) and discard.

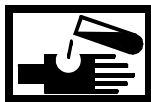
WARNING**CHEMICAL****EYE PROTECTION****POISON****VAPOR**

- h. Remove drain pan and dispose of its contents in accordance with local procedures.

INSTALL FRESH WATER COOLING SYSTEM THERMOSTAT

1. Install port thermostats (1).

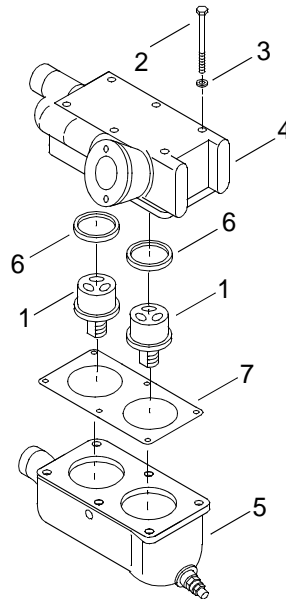

- a. Install new gasket (7) on thermostat housing (5).
- b. Install new seals (6) in thermostat housing cover (4).
- c. Install new thermostats (1) in thermostat housing cover (4).

- d. Install thermostat cover (4) on thermostat housing (5).
 - e. Install six washers (3) and cap screws (2) on the left bank thermostat cover (4).
 - f. Using a torque wrench and socket set, torque cap screws (2) to 360-420 in. lbs (41-47 N-m).
2. Install starboard thermostats (8).

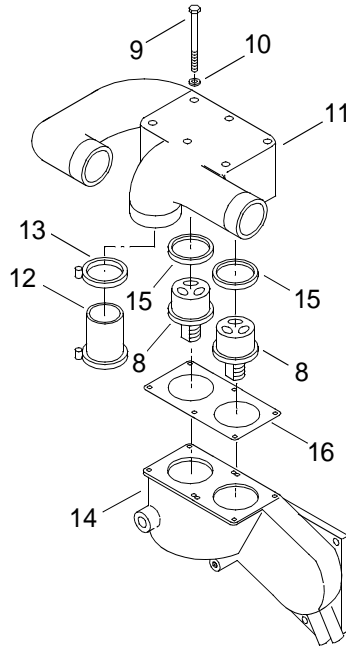

- a. Install new gasket (16) on thermostat housing (14).
- b. Install new seals (15) in thermostat housing cover (11).
- c. Install new thermostats (8) in thermostat housing cover (11).
- d. Install thermostat cover (11) on thermostat housing (14).
- e. Install six lock washers (10) and cap screws (9) in the right bank thermostat cover (7).
- f. Using a torque wrench and socket set, torque cap screws (9) to 360-420 in. lbs (41-47 N-m).
- g. Connect water pump hose (12) to the right bank thermostat cover (11).
 - {1} Connect water pump hose (12) to right bank thermostat cover (11).
 - {2} Slide clamp (13) on hose (12).
 - {3} Tighten clamp (13).

WARNING

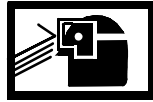
**CHEMICAL****EYE PROTECTION****POISON****VAPOR****SLICK FLOOR**

3. Clean up spilled fluid with spill kit and dispose of spill kit waste in accordance with local procedures
4. Install fresh water cooling system bypass tube. (WP 0148 00)
5. Install fuel system block. (WP 0085 00)
6. Install cold start temperature switch. (WP 0172 00)
7. Install fuel oil pressure switch. (WP 0179 00)
8. Install electrical system engine normal stop push button mounting bracket. (WP 0166 00)
9. Install electrical system engine normal stop push button. (WP 0165 00)
10. Service fresh water cooling system. (WP 0133 00)
11. Install engine deck hatch. (TM 55-1945-205-24-1-1)
12. Install powered section exhaust plenum. (TM 55-1945-205-24-1-1)
13. Install powered section intake plenum assembly. (TM 55-1945-205-24-1-1)
14. Install powered section operators cab. (TM 55-1945-205-24-1-1)
15. Install SINCGARS antenna. (TM 11-5820-890-10-8)
16. Install main navigation mast. (TM 55-1945-205-24-1-1)
17. Perform operational check of diesel engine. (TM 55-1945-205-10-1)

END OF WORK PACKAGE

**UNIT LEVEL MAINTENANCE
CAUSEWAY FERRY
FRESH WATER COOLING SYSTEM STARBOARD THERMOSTAT HOUSING
REPLACEMENT**

INITIAL SETUP:**Tools**

Tool Kit, General Mechanic's (Rail and Marine) (Item 131, WP 0188 00)
Gloves, Chemical (Item 52, WP 0188 00)
Goggles, Industrial (Item 54, WP 0188 00)

Materials/Parts

Housing
(72582)
PN 8921953
Gasket
(72582)
PN 5117993
Compound, Sealing (Item 30 WP 0187 00)
Compound, Sealing (Item 29, WP 0187 00)

Personnel Required

Engineer 88L

References

TM 55-1945-205-10-1

Equipment Condition

Main Navigation Mast Removed. (TM 55-1945-205-24-1-1)
Powered Section Operators Cab Removed. (TM 55-1945-205-24-1-1)
Powered Section Intake Plenum Assembly Removed. (TM 55-1945-205-24-1-1)
Engine Deck Hatch Removed. (TM 55-1945-205-24-1-1)
Engine Cool To Touch.
SINCGARS Antenna Removed. (TM 11-5820-890-10-8)
Fresh Water Cooling System Drained. (WP 0134 00)
Engine Fresh Water Cooling System ByPass Tube Removed. (WP 0148 00)
Engine Fresh Water Thermostats Removed. (WP 0143 00)

REMOVE FRESH WATER COOLING SYSTEM STARBOARD THERMOSTAT HOUSING**NOTE**

This task is typical for both port and starboard engines.

1. Remove three pipe plugs (1) from thermostat housing (2).

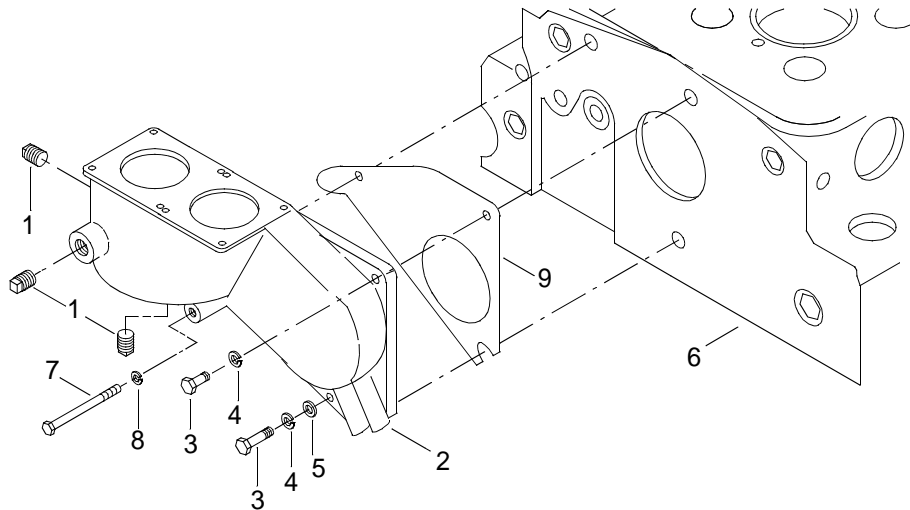

2. Remove two cap screws (3), lock washers (4) and one flat washer (5) securing thermostat housing (2) to cylinder head (6).
3. Remove one cap screw (7) and lock washer (8) securing thermostat housing (2) to cylinder head (6).
4. Remove thermostat housing (2) from cylinder head (6) and discard.
5. Remove gasket (9) from cylinder head (6) and discard.

INSTALL FRESH WATER COOLING SYSTEM STARBOARD THERMOSTAT HOUSING

1. Using a putty knife, clean gasket surface of cylinder head (6).

WARNING



CHEMICAL



EYE PROTECTION

2. Apply sealing compound to gasket surface of cylinder head (6).

WARNING



CHEMICAL



EYE PROTECTION

3. Apply sealing compound to gasket surface of new thermostat housing (2).
4. Install new gasket (9) on cylinder head (6).
5. Position new thermostat housing (2) on cylinder head (6).
6. Install one cap screw (7) and lock washer (8) securing thermostat housing (2) to cylinder head (6).

-
7. Install two cap screws (3) lock washers (4) and flat one washer (5) on thermostat housing (2).
 8. Tighten cap screws (3 and 7).

WARNING

**CHEMICAL****EYE PROTECTION**

9. Apply sealing compound to plugs (1).

WARNING

**CHEMICAL****EYE PROTECTION**

10. Install plugs (1) in thermostat housing (2).
11. Tighten plugs (1).
12. Install thermostats. (WP 0143 00)
13. Install cooling system bypass tube. (WP 0148 00)
14. Service cooling system. (WP 0133 00)
15. Install engine deck hatch. (TM 55-1945-205-24-1-1)
16. Install powered section exhaust plenum. (TM 55-1945-205-24-1-1)
17. Install powered section intake plenum assembly. (TM 55-1945-205-24-1-1)
18. Install powered section operators cab. (TM 55-1945-205-24-1-1)
19. Install main navigation mast. (TM 55-1945-205-24-1-1)
20. Install SINGARS antenna. (TM 11-5820-890-10-8)
21. Start engine. (TM 55-1945-205-10-1)
22. Run engine for five minutes once operating temperature is reached.
23. Verify that thermostat housing has no leaks.
24. Shut engine down. (TM 55-1945-205-10-1)

END OF WORK PACKAGE

**UNIT LEVEL MAINTENANCE
CAUSEWAY FERRY
FRESH WATER COOLING SYSTEM PORT THERMOSTAT HOUSING
REPLACEMENT**

INITIAL SETUP:**Tools**

Tool Kit, General Mechanic's (Rail and Marine) (Item 131, WP 0188 00)
Gloves, Chemical (Item 52, WP 0188 00)
Goggles, Industrial (Item 54, WP 0188 00)

Materials/Parts

Housing
(72582)
PN 23501236
Gasket
(72582)
PN 5117993
Compound, Sealing (Item 30, WP 0187 00)
Tape, Antiseize (Item 34, WP 0187 00)

Personnel Required

Engineer 88L

References

TM 55-1945-205-10-1

Equipment Condition

Engine Cool To Touch.
SINCGARS Antenna Removed. (TM 11-5820-890-10-8)
Main Navigation Mast Removed. (TM 55-1945-205-24-1-1)
Powered Section Operators Cab Removed. (TM 55-1945-205-24-1-1)
Powered Section Intake Plenum Assembly Removed. (TM 55-1945-205-24-1-1)
Powered Section Exhaust Plenum Removed. (TM 55-1945-205-24-1-1)
Engine Deck Hatch Removed. (TTM 55-1945-205-24-1-1)
Fresh Water Cooling System Drained. (WP 0134 00)
Fresh Water Cooling System By Pass Tube Removed. (WP 0148 00)
Auto Shutdown System Fuel Oil Pressure Switch Removed. (WP 0179 00)
Cold Start Temperature Switch Removed. (WP 0172 00)
Fuel System Block Removed. (WP 0085 00)
Fresh Water Cooling System Removed Thermostat Removed. (WP 0143 00)
Auto Shutdown System High Water Temperature Switch Removed. (WP 0177 00)

REMOVE FRESH WATER COOLING SYSTEM PORT THERMOSTAT HOUSING**NOTE**

This task is typical for both port and starboard engines.

1. Remove bushing (1) from thermostat housing (2).

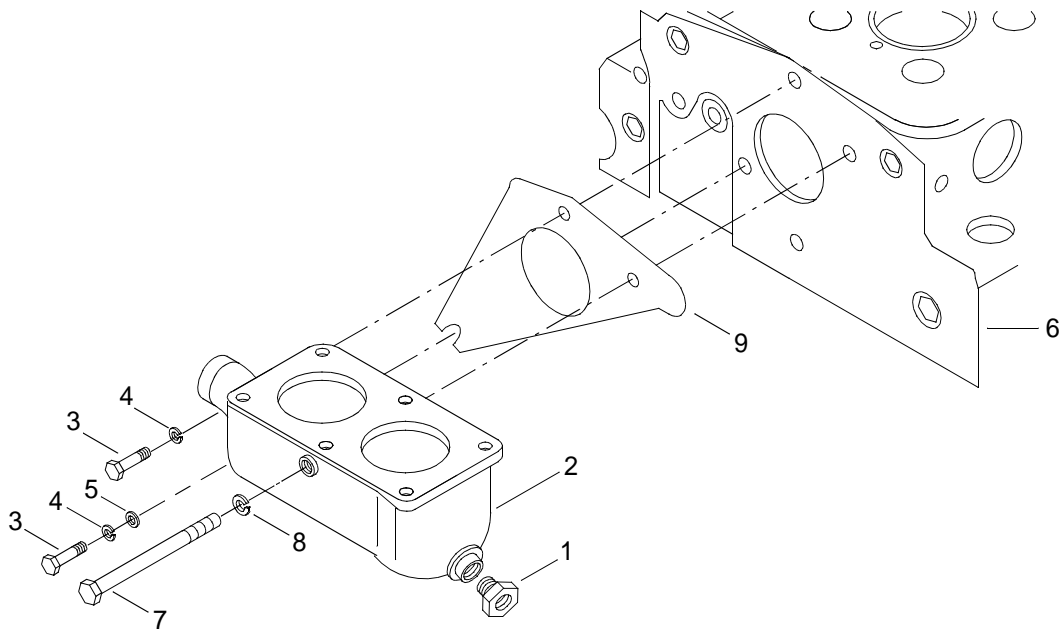

2. Remove two cap screws (3), lock washers (4) and one flat washer (5) securing thermostat housing (2) to cylinder head (6).
3. Remove one cap screw (7) and lock washer (8) securing thermostat housing (2) to cylinder head (6).
4. Remove thermostat housing (2) from cylinder head (6) and discard.
5. Remove gasket (9) from cylinder head (6) and discard.

INSTALL FRESH WATER COOLING SYSTEM PORT THERMOSTAT HOUSING

1. Using putty knife, clean gasket surface of cylinder head (6).

WARNING

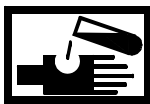

CHEMICAL



EYE PROTECTION

2. Apply sealing compound to gasket surface of cylinder head (6).

WARNING

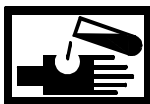

CHEMICAL



EYE PROTECTION

3. Apply sealing compound to gasket surface of thermostat housing (2).
4. Position new gasket (9) on cylinder head (6).

-
5. Install new thermostat housing (2) on cylinder head (6).
 6. Install one cap screw (7) and lock washer (8) securing thermostat housing (2) to cylinder head (6).
 7. Install two cap screws (4) lock washers (5) and one flat washer (6) on thermostat housing (2).
 8. Wrap bushing (1) threads with antiseize tape.
 9. Install bushing (1) in thermostat housing (2).
 10. Install auto shutdown system high water temperature switch. (WP 0177 00)
 11. Install fresh water cooling system thermostat. (WP 0143 00)
 12. Install fuel system block. (WP 0085 00)
 13. Install cold start temperature switch. (WP 0172 00)
 14. Install auto shutdown system fuel oil pressure switch. (WP 0179 00)
 15. Install fresh water cooling system by-pass tube. (WP 0148 00)
 16. Service fresh water cooling system. (WP 0133 00)
 17. Install engine deck hatch. (TM 55-1945-205-24-1-1)
 18. Install powered section exhaust plenum. (TM 55-1945-205-24-1-1)
 19. Install powered section intake plenum assembly. (TM 55-1945-205-24-1-1)
 20. Install powered section operators cab. (TM 55-1945-205-24-1-1)
 21. Install main navigation mast. (TM 55-1945-205-24-1-1)
 22. Install SINCGARS antenna. (TM 11-5820-890-10-8)
 23. Start engine. (TM 55-1945-205-10-1)
 24. Run engine for five minutes once operating temperature is reached.
 25. Verify that thermostat housing has no leaks.
 26. Shut engine down. (TM 55-1945-205-10-1)

END OF WORK PACKAGE

**UNIT LEVEL MAINTENANCE
CAUSEWAY FERRY
FRESH WATER COOLING SYSTEM THERMOSTAT
TESTING**

INITIAL SETUP:**Tools**

- Tool Kit, General Mechanic's (Rail and Marine) (Item 131, WP 0188 00)
- Thermometer, Self-Indicating (Item 127, WP 0188 00)
- Heater (Item 64, WP 0188 00)
- Pail, Utility (Item 86, WP 0188 00)

Personnel Required

Engineer 88L

TEST FRESH WATER COOLING SYSTEM THERMOSTAT

1. Fill utility pail (1) with water.

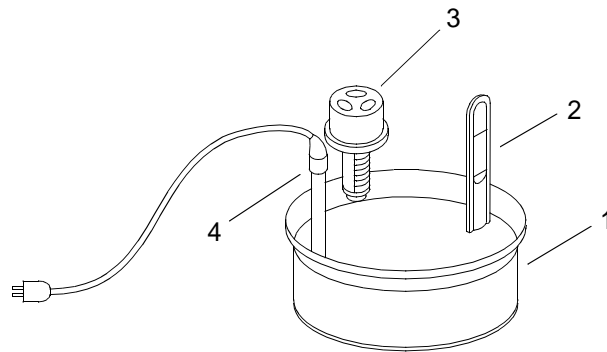
**NOTE**

Do not allow the thermometer to touch the bottom of the utility pail.

2. Place thermometer (2) in the utility pail (1).
3. Place thermostat (3) in the utility pail (1).
4. Place heater (4) in utility pail (1).

WARNING

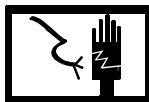
**ELECTRICAL****HOT AREA**

5. Turn on the heater (4).

WARNING

**ELECTRICAL****HOT AREA**

6. Agitate the hot water to disperse the temperature evenly throughout the water.
7. As the water is heated, verify the thermostat (3) opens at approximately 188°-197°F (85°-92°C) on the thermometer (2).
8. Allow the thermometer (2) to stabilize for approximately 10 minutes after reaching the desired temperature.
9. Verify the thermometer (2) temperature to ensure validity of the thermostat (3) opening point.
10. Turn off heater (4).

WARNING

**HOT AREA**

11. Remove thermostat (3) from utility pail (1).
12. Allow thermostat (3) to cool and watch it close.

END OF WORK PACKAGE

**UNIT LEVEL MAINTENANCE
CAUSEWAY FERRY
FRESH WATER TEMPERATURE SENDING UNIT
REPLACEMENT**

INITIAL SETUP:**Tools**

Tool Kit, General Mechanic's (Rail and Marine) (Item 131, WP 0188 00)
Gloves (Item 52, WP 0188 00)
Goggles (Item 54, WP 0188 00)
Apron, Utility (Item 8, WP 0188 00)
Respirator, Air Filtering (Item 109, WP 0188 00)
Pan, Drain (Item 87, WP 0188 00)

Materials/Parts

Switch, Thermostatic
(3B518)
NSN 5930-00-407-9407
PN 5146080
Spill Clean-up Kit, Hazardous Material (Item 32, WP 0187 00)

Personnel Required

Engineer 88L

References

TM 55-1945-205-10-1

REMOVE WATER TEMPERATURE SENDING UNIT

1. Verify MAIN circuit breaker (1) on propulsion module circuit breaker panel A6 is off.

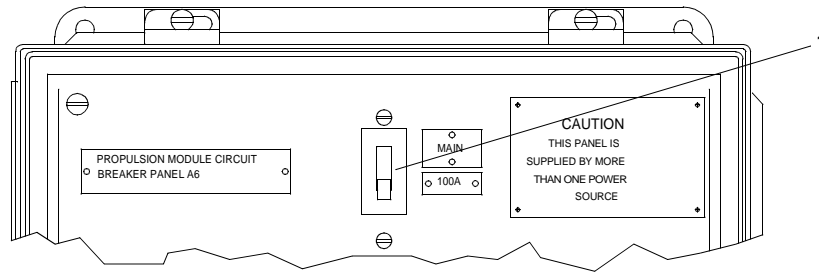

- Lift and slide back two insulators (2) from engine water temperature sending unit terminals (3).

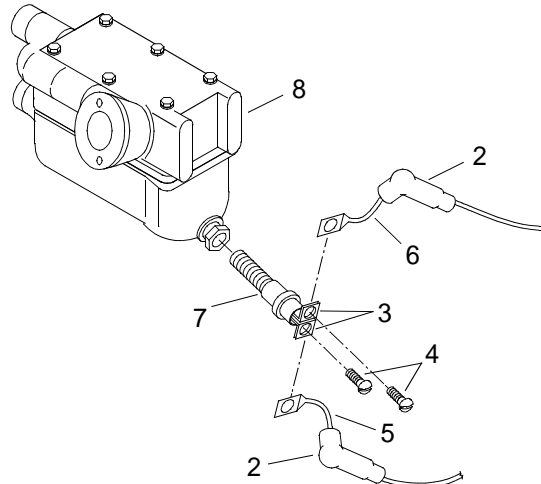

- Remove two screws (4) attaching wires (5 and 6) to engine water temperature sending unit terminals (3).
- Remove two wires (5 and 6) from engine water temperature sending unit terminals (3).
- Place a drain pan under water temperature sending unit (7).

WARNING



CHEMICAL



EYE PROTECTION



POISON



VAPOR

- Remove engine water temperature sending unit (7) from thermostat housing (8) and discard.

WARNING



CHEMICAL



EYE PROTECTION



POISON



VAPOR

- Remove drain pan and dispose of contents in accordance with local procedures.

INSTALL WATER TEMPERATURE SENDING UNIT

- Install new engine water temperature sending unit (7) in thermostat housing (8)
- Position two wires (5 and 6) to engine water temperature sending unit terminals (3).
- Install two screws (4) attaching wires (5 and 6) to engine water temperature sending unit terminals (3).
- Slide two insulators (2) on engine water temperature sending unit terminals (3).
- Service fresh water cooling system. (WP 0133 00)

WARNING

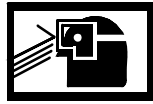
**CHEMICAL****EYE PROTECTION****POISON****VAPOR****SLICK FLOOR**

6. Clean up spilled fluids with spill kit and dispose of spill kit waste in accordance with local procedure.

END OF WORK PACKAGE

**UNIT LEVEL MAINTENANCE
CAUSEWAY FERRY
FRESH WATER COOLING SYSTEM BYPASS HOSES
REPLACEMENT**

INITIAL SETUP:**Tools**

Tool Kit, General Mechanic's (Rail and Marine) (Item 131, WP 0188 00)
Respirator, Air Filtering (Item 109, WP 0188 00)
Goggles, Industrial (Item 54, WP 0188 00)
Gloves, Rubber (Item 52, WP 0188 00)

Materials/Parts

Tube Assembly, Metal
(72582)
NSN 4710-00-898-4281
PN 5122398
Hose, Nonmetallic
(72582)
NSN 4720-01-039-6518
PN 519978

Personnel Required

Engineer 88L

References

TM 55-1945-205-10-1

Equipment Condition

Main Navigation Mast Removed. (TM 55-1945-205-24-1-1)
SINGARS Antenna Removed. (TM 11-5820-890-10-8)
Powered Section Operators Cab Removed. (TM 55-1945-205-24-1-1)
Powered Section Intake Plenum Assembly Removed. (TM 55-1945-205-24-1-1)
Engine Hatch Removed. (TM 55-1945-205-24-1-1)
Engine Cool To Touch.
Fresh Water Cooling System Drained. (WP 0134 00)

REMOVE FRESH WATER COOLING SYSTEM BYPASS HOSES

WARNING



EYE PROTECTION



POISON



VAPOR



CHEMICAL

NOTE

This task is typical for both port and starboard engines.

1. Loosen four hose clamps (1).

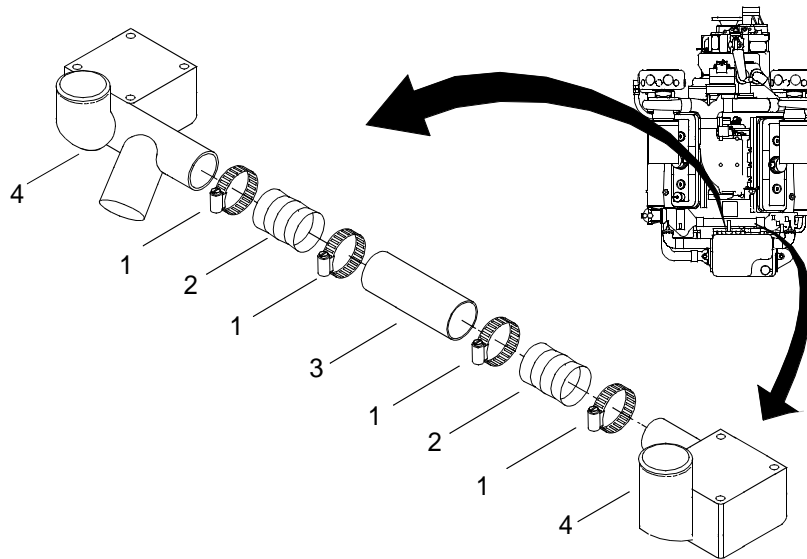

2. Remove clamps (1), hoses (2) and tube (3) from thermostat housings (4).
3. Discard hoses (2) and tube (3).

INSTALL FRESH WATER COOLING SYSTEM BYPASS HOSES

1. Install hose clamps (1) on new hoses (2).
2. Assemble new hoses (2) and tube (3).
3. Install hoses (2) and tube (3) on thermostat housing (4).
4. Tighten hose clamps (1).
5. Service fresh water cooling system. (WP 0133 00)
6. Install engine deck hatch. (TM 55-1945-205-24-1-1)
7. Install powered section operators cab. (TM 55-1945-205-24-1-1)
8. Install SINGARS antenna. (TM 11-5820-890-10-8)
9. Install powered section intake plenum assembly. (TM 55-1945-205-24-1-1)
10. Install main navigation mast. (TM 55-1945-205-24-1-1)
11. Start engine. (TM 55-1945-205-10-1)
12. Check hoses (2) and tube (3) for leaks.
13. Shut engine down. (TM 55-1945-205-10-1)

END OF WORK PACKAGE

**UNIT LEVEL MAINTENANCE
CAUSEWAY FERRY
FRESH WATER COOLING SYSTEM COOLANT HOSES
REPLACEMENT**

INITIAL SETUP:**Tools**

Tool Kit, General Mechanic's (Rail and Marine) (Item 131, WP 0188 00)
Gloves, Chemical (Item 52, WP 0188 00)
Goggles, Industrial (Item 54, WP 0188 00)
Pan, Drain (Item 87, WP 0188 00)

Materials/Parts

Spill Clean-up Kit, Hazardous Material (Item 32, WP 0187 00)

Personnel Required

Engineer 88L

References

TM 55-1945-205-10-1

Equipment Condition

Engine Cool To Touch.
Fresh Water Cooling System Drained. (WP 0134 00)

REMOVE FRESH WATER COOLING SYSTEM RUBBER HOSES WITH CLAMPS**NOTE**

The following procedures are typical for both port and starboard engines.

1. Place drain pan under hose being removed for draining residual coolant from hose.
2. Loosen clamps (1) holding hose (2) in place.

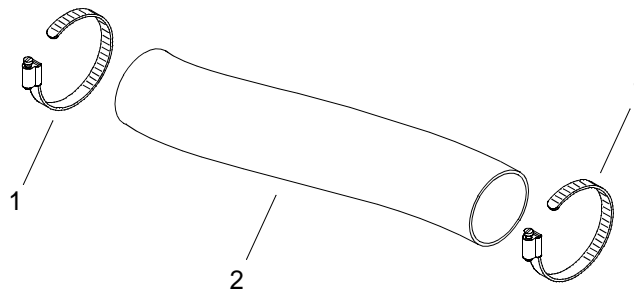

3. Slide clamps (1) back onto hose (2) at both ends of hose (2).

WARNING



CHEMICAL

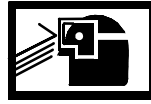

EYE PROTECTION

- Pull hose (2) away from connection.

WARNING



CHEMICAL



EYE PROTECTION

- Drain residual coolant into drain pan.

WARNING

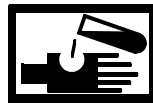

CHEMICAL



EYE PROTECTION



SLICK FLOOR

- Remove drain pan and dispose of contents in accordance with local procedures.

INSTALL FRESH WATER COOLING SYSTEM RUBBER HOSES WITH CLAMPS

- Install hose clamps onto hose (2).
- Install new hose (2) onto both connecting points.
- Slide clamps (1) down hose until clamp (1) is in a position to hold hose (2) in place at the connection point.
- Tighten clamps (1) holding hose (2) in place.

WARNING

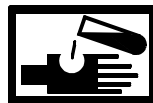

CHEMICAL



EYE PROTECTION



SLICK FLOOR

- Clean up spilled fluid with a spill kit and dispose of spill kit waste in accordance with local procedures.
- Perform operational checks. (TM 55-1945-205-10-1)

REMOVAL OF RUBBER HOSES WITH B-NUTS

1. Place drain pan under hose being removed for draining residual coolant from hose.
2. Turn b-nut (3) counterclockwise, until loose.

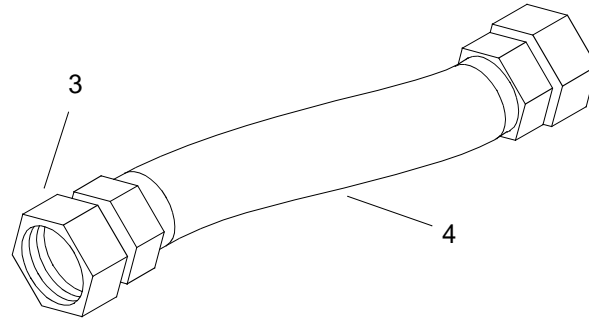

WARNING

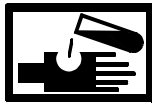

CHEMICAL

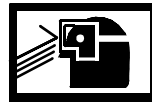

EYE PROTECTION

3. Remove b-nut (3) by hand and remove hose (4) from connection point.

WARNING



CHEMICAL

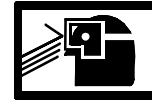

EYE PROTECTION

4. Drain residual coolant into drain pan.

WARNING

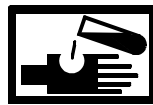

CHEMICAL



EYE PROTECTION



SLICK FLOOR

5. Clean up spilled fluid with a spill kit and dispose of spill kit waste in accordance with local procedures.

INSTALL RUBBER HOSES WITH B-NUT

1. Thread b-nut (3) onto both connecting points hand tight.

CAUTION

Do not overtighten b-nut or damage to fitting threads will occur.

2. Tighten b-nut (3) onto connecting points at both ends.

WARNING**CHEMICAL****EYE PROTECTION****SLICK FLOOR**

3. Clean up spilled fluid with a spill kit and dispose of spill kit waste in accordance with local procedures.
4. Fill cooling system. (WP 0133 00)
5. Perform operational check of diesel engine. (TM 55-1945-205-10-1)

END OF WORK PACKAGE

**DIRECT SUPPORT MAINTENANCE
CAUSEWAY FERRY
FRESH WATER COOLING SYSTEM PORT WATER OUTLET MANIFOLD
REPLACEMENT**

INITIAL SETUP:**Tools**

Tool Kit, General Mechanic's (Rail and Marine) (Item 131, WP 0188 00)
Wrench, Pipe (Item 136, WP 0188 00)
Gloves, Chemical (Item 52, WP 0188 00)
Goggles, Industrial (Item 54, WP 0188 00)
Apron, Utility (Item 8, WP 0188 00)
Respirator, Air Filtering (Item 109, WP 0188 00)

Materials/Parts

Water Out Manifold
(72582)
PN 23501247
Gasket
(72582)
PN 51500361
Tape, Antiseize (Item 34, WP 0187 00)

Personnel Required

Engineer 88L

References

TM 55-1945-205-10-1

Equipment Condition

Main Navigation Mast Removed. (TM 55-1945-205-24-1-1)
SINCGARS Antenna Removed. (TM 11-5820-890-10-8)
Powered Section Operators Cab Removed. (TM 55-1945-205-24-1-1)
Powered Section Intake Plenum Assembly Removed. (TM 55-1945-205-24-1-1)
Powered Section Exhaust Plenum Removed. (TM 55-1945-205-24-1-1)
Engine Cool To Touch.
Cooling System Drained. (WP 0134 00)
Crankcase Breather Limiter Assembly Removed. (WP 0106 00)
Air Inlet Collector Assembly Removed. (WP 0104 00)
Cylinder Head Poppet Valve Rocker Arm Cover Removed. (WP 0043 00)
Turbocharger Removed. (WP 0114 00)

REMOVE FRESH WATER COOLING SYSTEM PORT WATER OUTLET MANIFOLD

1. Remove clamp (1) from hose (2).

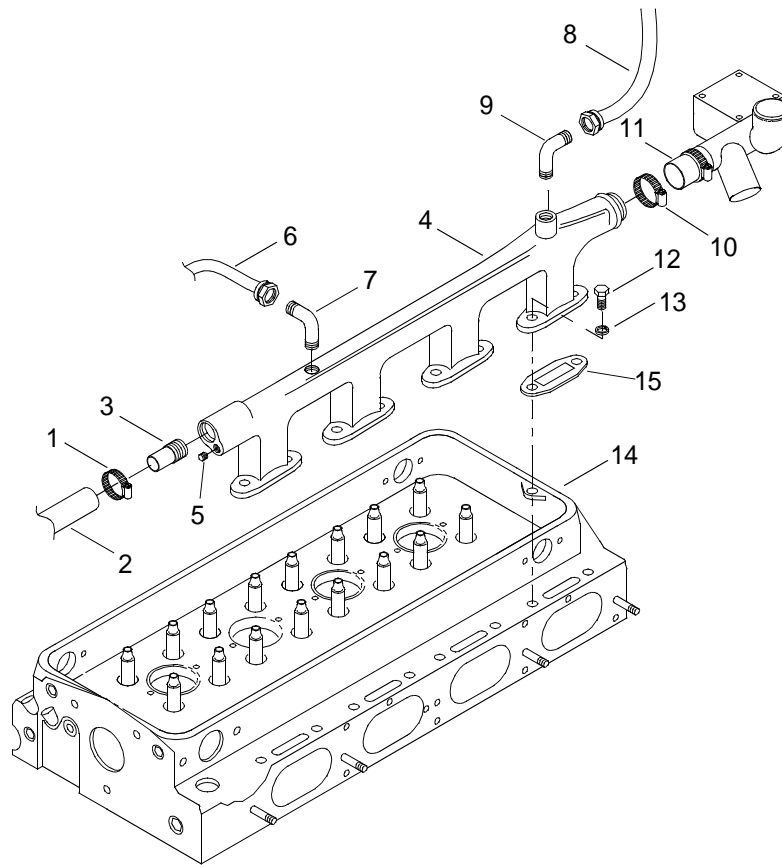

WARNING



CHEMICAL



EYE PROTECTION



POISON



VAPOR

2. Remove hose (2) from nipple (3).
3. Remove nipple (3) from water outlet manifold (4).
4. Remove plug (5) from water outlet manifold (4).

WARNING



CHEMICAL



EYE PROTECTION



POISON



VAPOR

5. Remove hose (6) from elbow (7).
6. Remove elbow (7) from water outlet manifold (4).

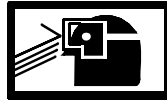
WARNING**CHEMICAL****EYE PROTECTION****POISON****VAPOR**

7. Remove hose (8) from elbow (9).
8. Remove elbow (9) from water outlet manifold (4).
9. Remove clamp (10) from seal (11) and water outlet manifold (4).
10. Remove eight cap screws (12) and lock washers (13) securing water outlet manifold (4) to cylinder head (14).

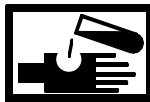
WARNING**CHEMICAL****EYE PROTECTION****POISON****VAPOR**

11. Remove water outlet manifold (4) and discard.
12. Remove and discard gaskets (15).

INSTALL FRESH WATER COOLING SYSTEM PORT WATER OUTLET MANIFOLD

1. Install new gaskets (15) on cylinder head (14).
2. Position new water outlet manifold (4) on cylinder head (14).
3. Install eight cap screws (12) and lock washers (13) securing water outlet manifold (4) to cylinder head (14).
4. Install clamp (10) on seal (11).
5. Wrap both ends of elbow (9) threads with antiseize tape.
6. Install elbow (9) on water outlet manifold (4).
7. Install hose (8) on elbow (9).
8. Wrap both end of elbow (7) threads with antiseize tape.
9. Install elbow (7) on water outlet manifold (4).
10. Install hose (6) on elbow (7).
11. Wrap plug (5) threads with antiseize tape.
12. Install plug (5) on water outlet manifold (4).
13. Wrap nipple (3) threads with antiseize tape.

14. Install nipple (3) on water outlet manifold (4).
15. Install hose (2) on nipple (3).
16. Install clamp (1) on hose (2).
17. Install cylinder head poppet valve rocker arm cover. (WP 0043 00)
18. Install turbocharger. (WP 0114 00)
19. Install air inlet collector assembly. (WP 0104 00)
20. Install crankcase breather limiter assembly. (WP 0106 00)
21. Service cooling system. (WP 0133 00)
22. Install engine deck hatch. (TM 55-1945-205-24-1-1)
23. Install powered section operators cab. (TM 55-1945-205-24-1-1)
24. Install SINGARS antenna. (TM 11-5820-890-10-8)
25. Install powered section intake plenum assembly. (TM 55-1945-205-24-1-1)
26. Install main navigation mast. (TM 55-1945-205-24-1-1)
27. Start engine. (TM 55-1945-205-10-1)
28. Check water outlet manifold (4) for leaks.
29. Shut engine down. (TM 55-1945-205-10-1)

END OF WORK PACKAGE

**DIRECT SUPPORT MAINTENANCE
CAUSEWAY FERRY
FRESH WATER COOLING SYSTEM STARBOARD WATER OUTLET MANIFOLD
REPLACEMENT**

INITIAL SETUP:**Tools**

Tool Kit, General Mechanic's (Item 130, WP 0188 00)
Gloves, Chemical (Item 52, WP 0188 00)
Goggles, Industrial (Item 54, WP 0188 00)
Apron, Utility (Item 8, WP 0188 00)
Respirator, Air Filtering (Item 109, WP 0188 00)
Wrench, Pipe (10 in.) (Item 136, WP 0188 00)

Materials/Parts

Water Out Manifold
(72582)
PN 23501247
Gasket
(72582)
PN 51500361
Tape, Antiseize (Item 34, WP 0187 00)

Personnel Required

Engineer 88L

References

TM 55-1945-205-10-1

Equipment Condition

Main Navigation Mast Removed. (TM 55-1945-205-24-1-1)
SINGGARS Antenna Removed. (TM 11-5820-890-10-8)
Powered Section Operators Cab Removed. (TM 55-1945-205-24-1-1)
Powered Section Intake Plenum Assembly Removed. (TM 55-1945-205-24-1-1)
Powered Section Exhaust Plenum Removed. (TM 55-1945-205-24-1-1)
Engine Cool To Touch.
Cooling System Drained. (WP 0134 00)
Crankcase Breather Limiter Assembly Removed. (WP 0106 00)
Air Inlet Collector Assembly Removed. (WP 0104 00)
Cylinder Head Poppet Valve Rocker Arm Cover Removed. (WP 0043 00)
Turbocharger Removed. (WP 0114 00)

REMOVE FRESH WATER COOLING SYSTEM STARBOARD WATER OUTLET MANIFOLD

1. Remove clamp (1) from hose (2).

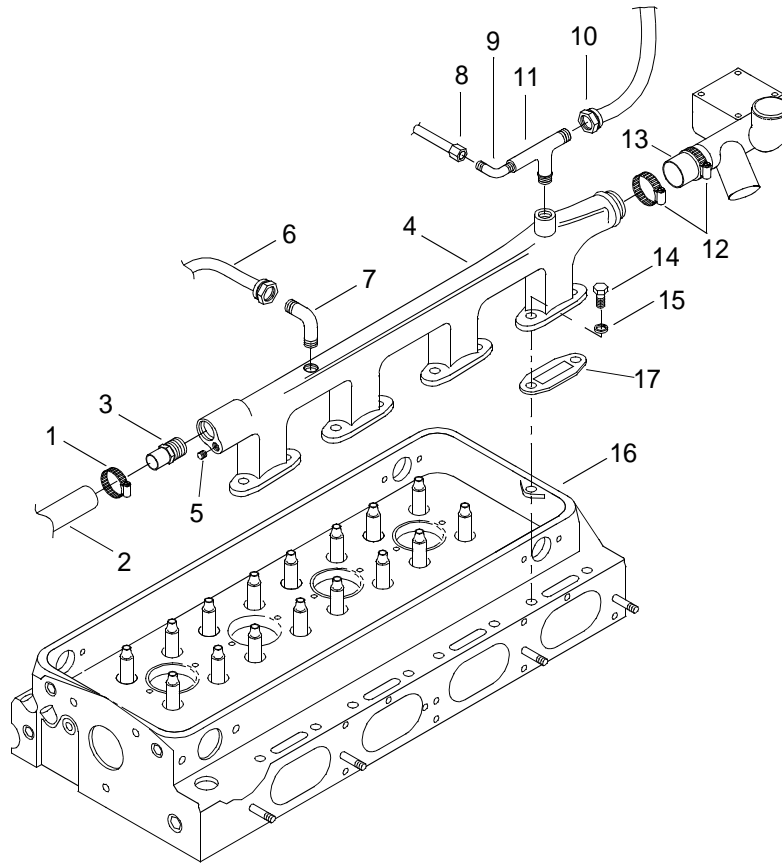

WARNING



CHEMICAL

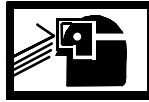

EYE PROTECTION



POISON



VAPOR

2. Remove hose (2) from nipple (3).
3. Remove nipple (3) from water outlet manifold (4).
4. Remove plug (5) from water outlet manifold (4).

WARNING



CHEMICAL



EYE PROTECTION



POISON



VAPOR

5. Remove hose (6) from elbow (7).
6. Remove elbow (7) from water outlet manifold (4).

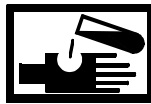
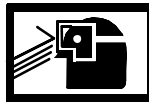
WARNING**CHEMICAL****EYE PROTECTION****POISON****VAPOR**

- Remove hose (8) from elbow fitting (9).

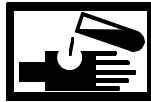
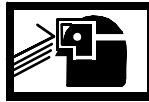
WARNING**CHEMICAL****EYE PROTECTION****POISON****VAPOR**

- Remove hose (10) from tee fitting (11).
- Remove tee fitting (11) from water outlet manifold (4).
- Remove clamp (12) from seal (13) and water outlet manifold (4).
- Remove eight cap screws (14) and lock washers (15) securing water outlet manifold (4) to cylinder head (16).

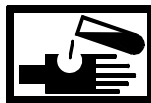
WARNING**CHEMICAL****EYE PROTECTION****POISON****VAPOR**

- Remove water outlet manifold (4) and discard.
- Remove and discard gaskets (17).

INSTALL FRESH WATER COOLING SYSTEM STARBOARD WATER OUTLET MANIFOLD

- Install new gaskets (17) on cylinder head (16).
- Position new water outlet manifold (4) on cylinder head (16).
- Install eight cap screws (14) and lock washers (15) securing water outlet manifold (4) to cylinder head (16).
- Install clamp (12) on seal (13).
- Wrap all ends of tee fitting (11) threads with antiseize tape.
- Install tee fitting (11) on water outlet manifold (4).
- Connect hose (10) to tee fitting (11).
- Connect hose (8) to elbow fitting (9).

9. Wrap both ends of elbow (7) threads with antiseize tape.
10. Install elbow (7) on water outlet manifold (4).
11. Connect hose (6) to elbow (7).
12. Wrap plug (5) threads with antiseize tape.
13. Install plug (5) on water outlet manifold (4).
14. Wrap nipple (3) threads with antiseize tape.
15. Install nipple (3) on water outlet manifold (4).
16. Install hose (2) on nipple (3).
17. Install clamp (1) on hose (2).
18. Install cylinder head poppet valve rocker arm cover. (WP 0043 00)
19. Install turbocharger. (WP 0114 00)
20. Install air inlet collector assembly. (WP 0104 00)
21. Install crankcase breather limiter assembly. (WP 0106 00)
22. Service cooling system. (WP 0133 00)
23. Install engine deck hatch. (TM 55-1945-205-24-1-1)
24. Install powered section operators cab. (TM 55-1945-205-24-1-1)
25. Install SINGARS antenna. (TM 11-5820-890-10-8)
26. Install powered section intake plenum assembly. (TM 55-1945-205-24-1-1)
27. Install main navigation mast. (TM 55-1945-205-24-1-1)
28. Start engine. (TM 55-1945-205-10-1)
29. Check water outlet manifold (4) for leaks.
30. Shut engine down. (TM 55-1945-205-10-1)

END OF WORK PACKAGE

**DIRECT SUPPORT MAINTENANCE
CAUSEWAY FERRY
FRESH WATER COOLING SYSTEM PUMP
REMOVAL AND INSTALLATION**

INITIAL SETUP:**Tools**

Tool Kit, General Mechanic's (Item 130, WP 0188 00)
 Indicator, Dial (Item 67, WP 0188 00)
 Wrench, Torque (150-750 in. lbs) (Item 142, WP 0188 00)
 Wrench Set, Socket (3/8 in. sqdr.) (Item 135, WP 0188 00)
 Gloves, Chemical (Item 52, WP 0188 00)
 Goggles, Industrial (Item 54, WP 0188 00)
 Apron, Utility (Item 8, WP 0188 00)
 Respirator, Air Filtering (Item 109, WP 0188 00)
 Bolt, Machine (Item 13, WP 0188 00)

Materials/Parts

Gasket, Cover
 (72582)
 NSN 5330-00-758-2868
 PN 5117976
 Ring, Seal
 (72582)
 NSN 5330-01-088-6596
 PN 5103544

Personnel Required

Engineer 88L

References

TM 55-1945-205-10-1

Equipment Condition

Fresh Water Filter Removed. (WP 0140 00)
 Engine Fresh Water Cooling System Drained. (WP 0134 00)
 Fresh Water Cooling System Heat Exchanger Removed. (WP 0138 00)
 Fuel System Filter Removed. (WP 0079 00)

REMOVE FRESH WATER COOLING SYSTEM PUMP

WARNING

**CHEMICAL****EYE PROTECTION****POISON****VAPOR**

1. Loosen hose clamps (1) and remove three hoses (2) from pump body (3).

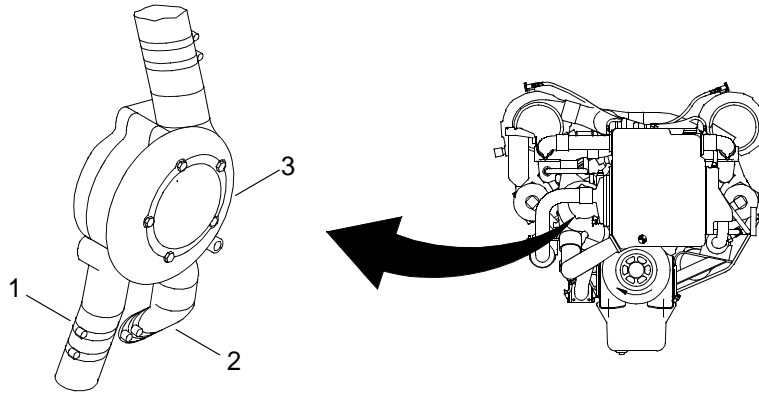

2. Remove mounting bolts (4), lock washers (5) and flat washer (6) from pump body (3).

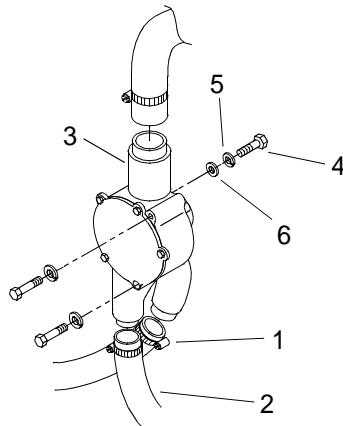

CAUTION

Do not damage gear teeth when disengaging the pump gear from the front camshaft gear or damage to engine may result.

3. Remove the pump body (3) from engine.

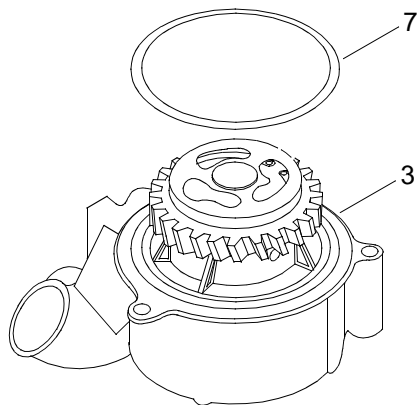

4. Remove and discard ring seal (7).

INSTALL FRESH WATER COOLING SYSTEM PUMP

1. Place new ring seal (7) on fresh water pump body (3).

CAUTION

Do not damage the gear teeth when engaging the pump gear to the front camshaft gear.

2. Mount pump body (3) on the engine so that the pump gear meshes with the camshaft gear.

NOTE

The flat washer identified as callout number (6) shall be installed on the top back bolt of the water pump.

3. Install pump body (3) to engine front cover using mounting bolts (4), lock washer (5) and flat washers (6).
4. Using torque wrench and socket set, torque the pump mounting bolts (4) to 420-456 in. lbs (47-52 N m).
5. Check gear backlash.
 - a. Remove cover bolts (8), and lock washers (9) securing water pump cover (10) and cover gasket (11).

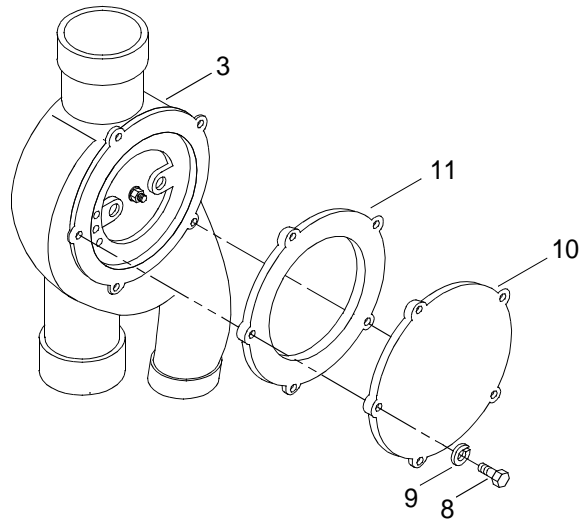

- b. Remove water pump cover (10) and cover gasket (11) from pump body (3).

- c. Install a 5/16th x 18 x 2 bolt (12) in the impeller (13) puller hole.

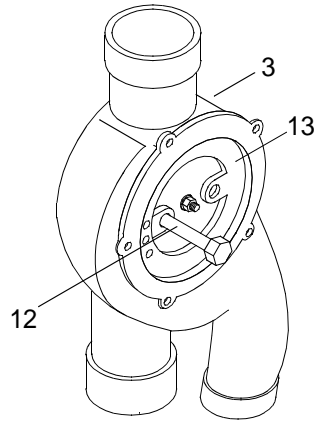

NOTE

Gear backlash setting should be 0.001" to 0.006".

- d. Using a dial indicator, measure the backlash at bolt (12) in impeller (13).
- {1} If specified backlash is not obtained, loosen the pump mounting bolts (4) and pivot the pump body (3) about the dowel pin to obtain proper lash adjustment.
- {2} Using torque wrench and socket set, torque the pump mounting bolts (4) to 420-456 in. lbs (47-52 N m).
- e. Remove bolt (12) from impeller (13).
- f. Install new cover gasket (9) and cover (8) with cover bolts (8) and lock washers (9).
6. Slide the hoses (2) into position and tighten hose clamps (1).
7. Install fuel system fuel filter. (WP 0079 00)
8. Install fresh water cooling system filter element. (WP 0140 00)
9. Install fresh water cooling system heat exchanger. (WP 0138 00)
10. Service fresh water cooling system. (WP 0133 00)
11. Perform operational check of diesel engine. (TM 55-1945-205-10-1)

END OF WORK PACKAGE

**DIRECT SUPPORT MAINTENANCE
CAUSEWAY FERRY
FRESH WATER COOLING SYSTEM PUMP DRIVE GEAR
REPLACEMENT**

INITIAL SETUP:**Tools**

Tool Kit, General Mechanic's (Item 130, WP 0188 00)
Wrench, Torque (100-600 ft lbs) (Item 139, WP 0188 00)
Wrench Set, Socket (¾ in. sqdr.) (Item 134, WP 0188 00)
Gloves, Chemical (Item 52, WP 0188 00)
Goggles, Industrial (Item 54, WP 0188 00)

Materials/Parts

Gear, Helical
(72582)
NSN 3020-00-537-0153
PN 5126904
Key, Woodruff
(72582)
NSN 5315-01-214-1876
PN 8926247
Grease, Ball and Roller Bearing (Item 21, WP 0187 00)

Personnel Required

Engineer 88L

References

TM 55-1945-205-10-1

Equipment Condition

Engine Cool To Touch.
SINCGARS Antenna Removed. (TM 11-5820-890-10-8)
Main Navigation Mast Removed. (TM 55-1945-205-24-1-1)
Operators Cab Removed. (TM 55-1945-205-24-1-1)
Intake Plenum Removed. (TM 55-1945-205-24-1-1)
Powered Section Engine Hatch Removed. (TM 55-1945-205-24-1-1)
Alternator Belt Guard Removed. (TM 55-1945-205-24-1-1)
Fresh Water Cooling System Drained. (WP 0134 00)
Fresh Water Cooling System Filter Element Removed. (WP 0140 00)
Fresh Water Cooling System Heat Exchanger Removed. (WP 0138 00)
Fuel Filter Cartridge Removed. (WP 0079 00)
Fresh Water Pump Removed. (WP 0152 00)
Rear Lifting Bracket Removed. (WP 0047 00)
Camshaft Vibration Damper Removed. (WP 0063 00)
Front Balance Weight Cover Removed. (WP 0076 00)

REMOVE FRESH WATER COOLING SYSTEM PUMP DRIVE GEAR

1. Remove hub (1) from drive gear (2).

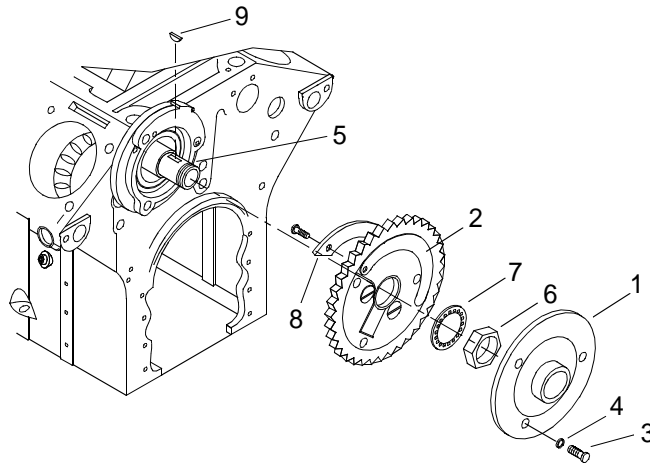

- a. Remove three screws (3) and lock washers (4).
- b. Remove hub (1).
2. Remove drive gear (2) from shaft (5).
 - a. Remove nut (6) and lock washer (7).
 - b. Remove drive gear and discard.
3. Remove engine camshaft balance weight (8) from drive gear (2). (WP 0065 00)
4. Remove woodruff key (9) from shaft (5).
5. Discard woodruff key (9).

INSTALL FRESH WATER COOLING SYSTEM PUMP DRIVE GEAR

1. Install new woodruff key (9) on shaft (5).
2. Install engine camshaft balance weight (8) on drive gear (2). (WP 0065 00)

WARNING



CHEMICAL

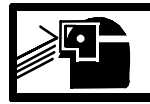

EYE PROTECTION

3. Apply a thin film of grease to shaft (5).
4. Install new drive gear (2) on shaft (5).
 - a. Install drive gear (2) on shaft (5).
 - b. While holding gear (2) in position, install lock washer (7) and nut (6) on shaft (5).
 - c. Using a torque wrench and socket set, torque nut (6) to 300-325 ft lbs (407-441 N-m).

-
5. Install hub (1) on drive gear (2).
 - a. Align hub (1) mounting holes with drive gear (2) mounting holes.
 - b. Install three lock washers (4) and screws (3). Tighten screws.
 6. Install front balance weight cover. (WP 0076 00)
 7. Install camshaft vibration damper. (WP 0063 00)
 8. Install rear lifting bracket. (WP 0047 00)
 9. Install fresh water pump. (WP 0152 00)
 10. Install fuel system filter. (WP 0079 00)
 11. Install fresh water cooling system heat exchanger. (WP 0138 00)
 12. Install fresh water cooling system filter element. (WP 0140 00)
 13. Fill fresh water cooling system. (WP 0133 00)
 14. Install alternator belt guard. (TM 55-1945-205-24-1-1)
 15. Install engine hatch. (TM 55-1945-205-24-1-1)
 16. Install intake plenum. (TM 55-1945-205-24-1-1)
 17. Install operators cab. (TM 55-1945-205-24-1-1)
 18. Install main navigation mast. (TM 55-1945-205-24-1-1)
 19. Install SINGARS antenna. (TM 11-5820-890-10-8)
 20. Perform operational check of diesel engine. (TM 55-1945-205-10-1)

END OF WORK PACKAGE

**DIRECT SUPPORT MAINTENANCE
CAUSEWAY FERRY
FRESH WATER COOLING SYSTEM PUMP
REPAIR**

INITIAL SETUP:**Tools**

Tool Kit, General Mechanic's (Item 130, WP 0188 00)
Inserter, Gear (Item 69, WP 0188 00)
Puller Kit, Universal (Item 100, WP 0188 00)
Press, Arbor, Hand Operated (Item 97, WP 0188 00)
Gloves, Chemical (Item 52, WP 0188 00)
Goggles, Industrial (Item 54, WP 0188 00)
Apron, Utility (Item 8, WP 0188 00)
Pliers, Retaining Ring (Item 94, WP 0188 00)
Compressor Unit, Reciprocating, Power Drive (Item 27, WP 0188 00)
Wrench Set, Socket (3/8 in. sqdr.) (Item 135, WP 0188 00)
Wrench, Torque (150-750 in. lbs) (Item 142, WP 0188 00)

Materials/Parts

Parts Kit, Engine Water Pump
(72582)
NSN 2930-00-706-7753
PN 23506367
Cleaner, Type II (Item 8, WP 0187 00)
Cloth, Cleaning (Item 13, WP 0187 00)
Compound, Sealing (Item, 30, WP 0187 00)
Adhesive (Item 1, WP 0187 00)
Grease, General Purpose (Item 22, WP 0187 00)
Lubricating Oil, Engine (Item 25, WP 0187 00)

Personnel Required

Engineer 88L

DISASSEMBLE FRESH WATER COOLING SYSTEM PUMP

1. Place pump (1) on a clean, dry working surface, with gear facing up.

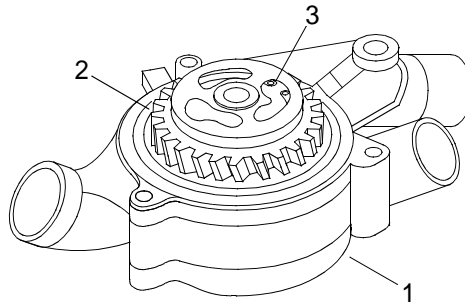

2. Rotate gear (2) until the holes of the retaining ring (3) are visible.

WARNING

**EYE PROTECTION****NOTE**

To assist in the removal of the retaining ring, a small screwdriver may be used for the removal with the retaining ring pliers.

- Using retaining ring pliers, slide pliers into slot of gear (2) and disengage retaining ring (3) from shaft of pump (1).

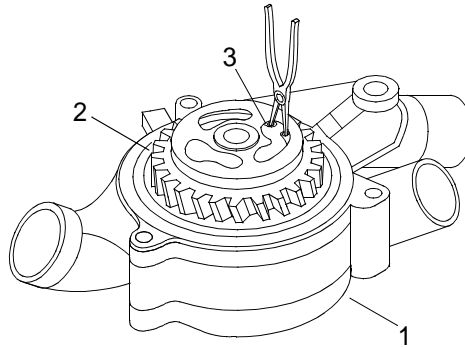

- Remove and discard retaining ring (3).
- Remove five bolts (4) securing pump cover (5) to pump (1).

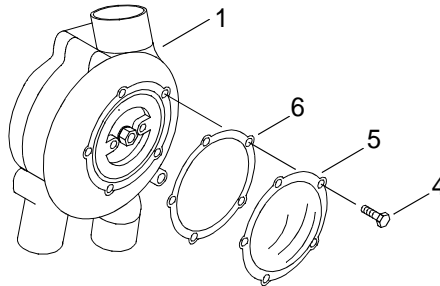

- Remove pump cover (5) and gasket (6). Discard gasket (6).

CAUTION

While holding gear during the following steps, care should be exercised to prevent damage to teeth on gear.

7. While holding gear on back side of pump (1) remove lock nut (7) and washer (8).

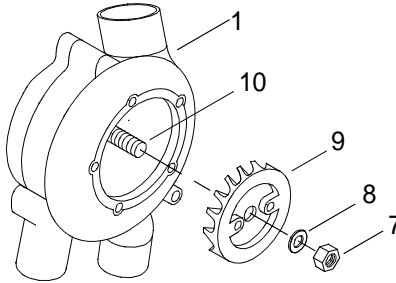

8. Install impeller puller onto impeller (9).
 9. Remove impeller (9) and discard.

CAUTION

Do not strike the gear teeth on the arbor press. Striking the teeth can result in damage to the gear.

10. Press the shaft (10) and pump gear (2) assembly out of the pump body (1).

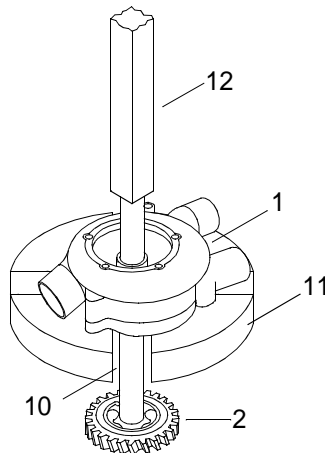

- a. Position pump (1) on the bed of an arbor press (11) with threaded end of shaft (10) up.
- b. Using a brass drift (12) as a buffer between the arbor press and the threaded shaft (10), press the gear (2) and shaft (10) from the pump body (1).
- c. Remove and discard retaining ring (3).
- d. Remove pump body (1) from bed of arbor press (11).

- e. Place the gear (2) on the bed of an arbor press (11) with the threads of the shaft (10) down.

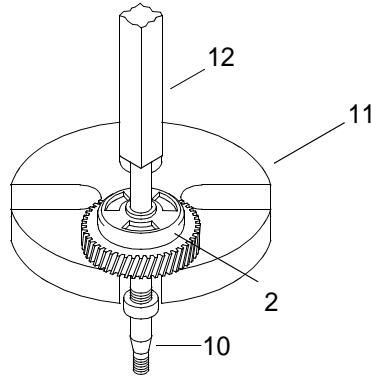

- f. Using a brass drift (12) as a buffer between the arbor press and the shaft (10), press the shaft (10) from gear (2). Discard shaft (10).

11. Push the oil seal (13) out of the pump body.

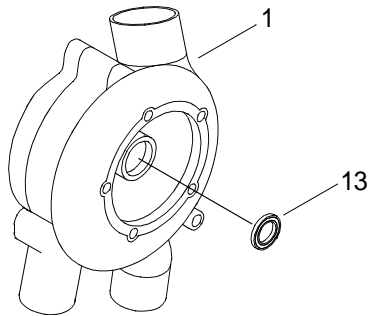

12. Twist the metal flange to break the water seal and boot assembly (14) away from pump body (1).

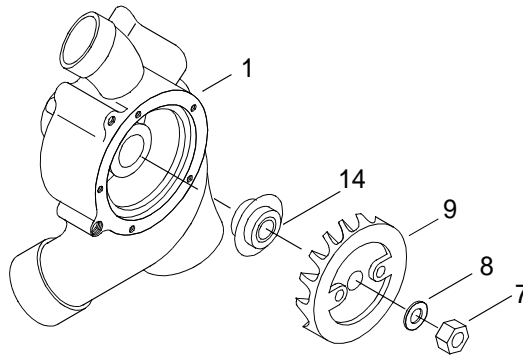

13. Remove seal and boot assembly (14) and discard.

14. Remove bearing outer (15) and discard.

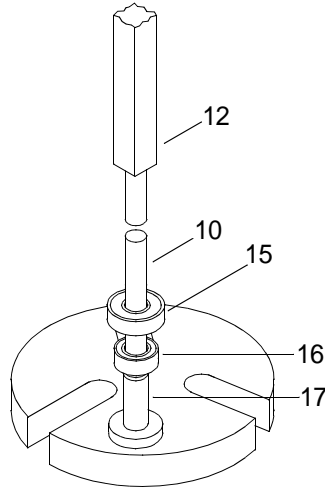

15. Remove bearing inner (16) and discard.

CLEAN WATER PUMP PARTS

1. Clean all parts of the fresh water pump using cleaner.
2. Assure all pump passages are free of any sediment or debris.

WARNING

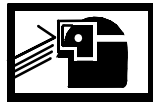

EYE PROTECTION



VAPOR

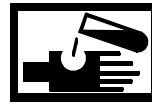

CHEMICAL

**Do not exceed 40 PSI (275 kPa) while drying the parts of the fresh water pump.
Failure to comply may result in injury to personnel.**

3. Dry all parts with compressed air.

INSPECT WATER PUMP

NOTE

During the following inspection procedure, any damage found is cause for rejection and replacement of part. No repair of individual parts is authorized.

1. Inspect gear (2) for chips, cracks or other damage.
2. Inspect water pump body (1) for cracks or any structural damage.

ASSEMBLE FRESH WATER COOLING SYSTEM PUMP

WARNING

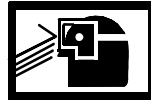
**CHEMICAL****EYE PROTECTION**

1. Lubricate the inner race of the new outer bearing (15) and new inner bearing (16) with grease.

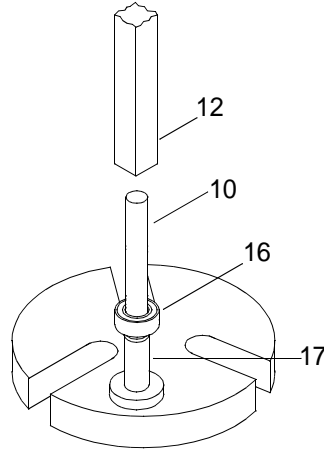

WARNING

**CHEMICAL****EYE PROTECTION**

2. Lubricate the bearing surface of the new shaft (10) with grease.
3. Place end of shaft (10) into gear installer (17).
4. Place new inner bearing (16) on shaft (10).
5. Using arbor press and a brass drift (11), press inner bearing (16) onto shaft (10).

6. Place new outer bearing (15) on end of shaft (10).

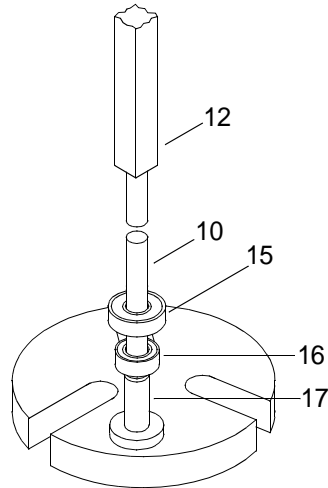

7. Using arbor press brass drift (12) and gear installer (17), press new outer bearing (15) onto shaft (10).
8. Remove shaft (10) from gear installer (17).

WARNING

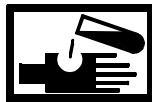

CHEMICAL



EYE PROTECTION

9. Apply a thin film of lubricating oil to the sealing lip of the new oil seal (13) and contact surface of the shaft (10).
10. Install the new oil seal (13) in the pump body (1) with the spring loaded lip toward the gear end of the pump body.

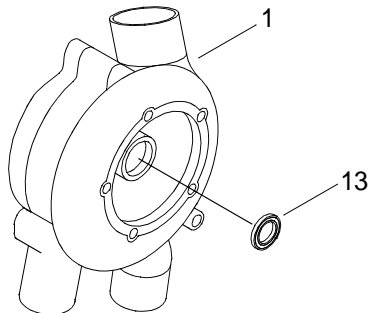

11. Seat the oil seal (13) until the seal is flush with the water seal counterbore in the pump body (1).

12. Using arbor press and brass drift (12), press the bearing and shaft assembly into the pump body (1).

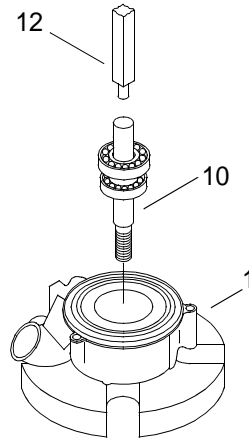

- a. Place the pump body (1) on the arbor press, cover side down.

CAUTION

During installation of the shaft and bearing assembly, avoid contacting the oil seal with the threaded shaft. damage to equipment may result.

- b. Install the shaft (10) and bearing assembly inside the pump body (1).
- c. Using arbor press and brass drift (12), press the shaft (10) and bearing assembly into the pump body (1).
13. Using the retaining ring pliers, place the bearing retaining ring (3) on the shaft (10).

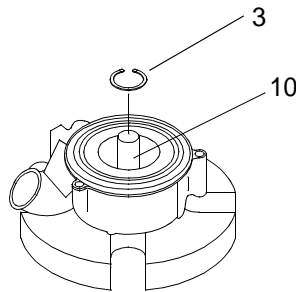

14. Press gear (2) onto shaft (10).
- a. Install gear installation tool (17) on threaded end of shaft (10).

- b. Place the pump body (1), cover side down, on the bed of the arbor press.

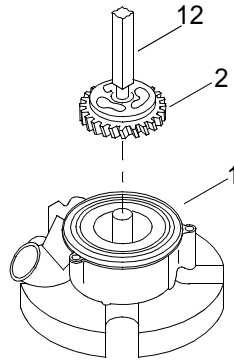

- c. Position the gear (2) between the press ram and the shaft (10).
- d. Using arbor press and brass drift (12), press the gear (2) onto the shaft (10) until the gear (2) is flush with the end of the shaft (10).

CAUTION

Do not touch the seal face during the following operation. The seal may be contaminated and allow the water pump to leak.

15. Press new water seal (14) into pump body (1).

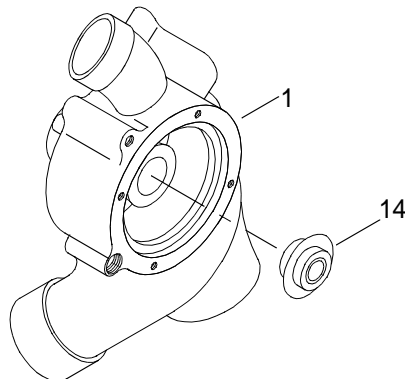

CAUTION

Do not strike the gear teeth on the arbor press. Striking the teeth can result in damage to the gear.

- a. Position pump body (1) on arbor press with cover side up.

WARNING

**CHEMICAL****EYE PROTECTION**

- b. Apply a thin coat of adhesive to outside diameter of water seal (14).
 - c. Place new seal (14) in cavity of pump body (1).
 - d. Press the water seal (14) into place.
16. Ensure water seal (14) and the impeller's (9) ceramic mating surfaces are clean, free of metal particles and oil film.

WARNING

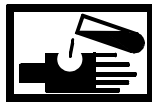
**CHEMICAL****EYE PROTECTION**

- 17. Apply a small amount of sealing compound to threads of shaft (10).
- 18. Install the impeller (9) onto the shaft (10).
- 19. Place a new washer (8) and nut (7) onto the threads of shaft (12).
- 20. Draw the impeller (9) down onto the shaft with the washer (8) and nut (7).
- 21. Using torque wrench and socket set, torque nut to 420 - 480 in. lbs (47.46 - 54.24 N-m).
- 22. Install new gasket (6) onto pump (1).
- 23. Place cover (5) on water pump (1).
- 24. Install five bolts (4) into water pump cover (5).
- 25. Tighten bolts (5).

END OF WORK PACKAGE

**DIRECT SUPPORT MAINTENANCE
CAUSEWAY FERRY
AFTERCOOLER
REPLACEMENT**

INITIAL SETUP:**Tools**

Tool Kit, General Mechanic's (Item 130, WP 0188 00)
Wrench, Torque (150-750 in. lbs) (Item 142, WP 0188 00)
Wrench Set, Socket (3/8 in. sqdr.) (Item 135, WP 0188 00)

Materials/Parts**Bolt**

(72582)
NSN 5306-01-120-3659
PN 5101196
Qty 8

Plate/Seal Assembly

(72582)
PN 23502200
Qty 1

O-Ring

(72582)
NSN 5331-01-370-8124
PN 23512847
Qty 1

Personnel Required

Engineer 88L

References

TM 55-1945-205-10-1

Equipment Condition

SINGARS Antenna Removed. (TM 11-5820-890-10-8)
Main Navigation Mast Removed. (TM 55-1945-205-24-1-1)
Operators Cab Removed. (TM 55-1945-205-24-1-1)
Intake Plenum Removed. (TM 55-1945-205-24-1-1)
Powered Section Engine Hatch Removed. (TM 55-1945-205-24-1-1)
Engine Cool To Touch.
Crankcase Breather Limiter Assembly Removed. (WP 0106 00)
Air Inlet Collector Assembly Removed. (WP 0104 00)
Cylinder Head Poppet Valve Rocker Arm Covers Removed. (WP 0043 00)
Fresh Water Cooling System Drained. (WP 0134 00)
Fresh Water Cooling System Bypass Hose Removed. (WP 0148 00)
Fuel Pump Removed. (WP 0094 00)
Air Intake Housing Removed. (WP 0103 00)
Tachometer Sending Unit Removed. (WP 0173 00)
Blower Drive Shaft And Spring Assembly Removed. (WP 0109 00)
Electronic Governor Rod Assembly Removed. (WP 0097 00)
Electronic Governor Actuator Removed. (WP 0098 00)
Blower Removed. (WP 0110 00)

REMOVE AFTERCOOLER

1. Verify MAIN circuit breaker (1) on propulsion module circuit breaker A6 is off.

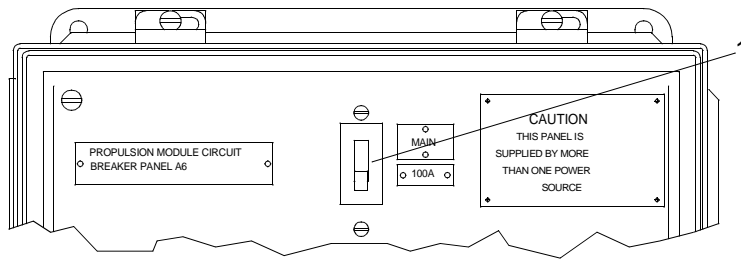

2. Verify fuel supply and return valves (2) are closed.

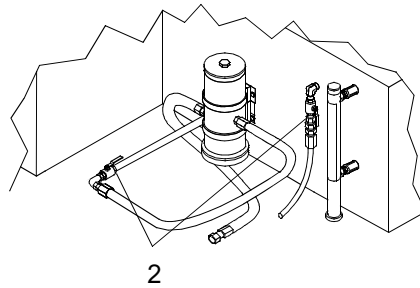

3. Loosen two hose clamps (3) and slide hose (4) back against thermostat housing (5).

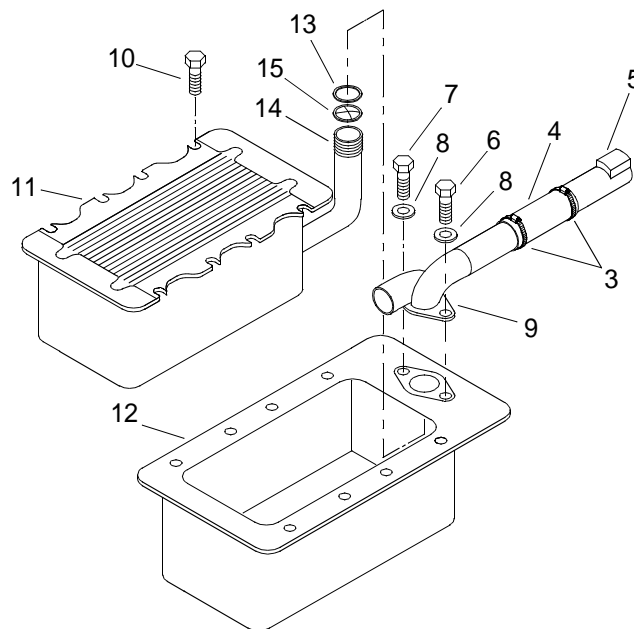

4. Remove two bolts (6) and (7), two washers (8) from water inlet/outlet fitting (9).
5. Remove water inlet/outlet fitting (9).
6. Remove and discard eight attaching bolts (10) with nylon locking patches from aftercooler (11).

CAUTION

Be careful not to damage cooler fins when lifting the aftercooler from the cylinder block.

7. Lift aftercooler (11) from cylinder block opening (12).

-
8. Remove and discard o-ring (13) from water inlet/outlet (14).
 9. Remove and discard plate and seal assembly (15) from water inlet/outlet (14).

INSTALL AFTERCOOLER

1. Install new plate and seal assembly (15) on water inlet/outlet (14).
2. Install new o-ring (13) on water inlet/outlet (14).
3. Place aftercooler (11), water inlet/outlet (14) end first, into cylinder block (12) opening.
4. Lower opposite end into cylinder block (12).
5. Ensure water inlet/outlet (14) is mated into cylinder block (12).
6. Loosely install eight new attaching bolts (10) with eight nylon locking patches onto aftercooler (11).
7. Align water inlet/outlet fitting (9) to the thermostat housing (5) with hose (4) and slide hose with clamps (3) onto water inlet/outlet fitting (9).
8. Tighten hose clamps (3).
9. Install water inlet/outlet fitting (9) using two bolts (6) and (7) and two washers (8).
10. Tighten eight aftercooler attaching bolts (10).
11. Using torque wrench and socket set, torque bolts (10) to 120-156 in. lbs (14 – 18 N-m).
12. Install blower. (WP 0110 00)
13. Install electronic governor actuator. (WP 0098 00)
14. Install electronic governor rod assembly. (WP 0097 00)
15. Install tachometer sending unit. (WP 0173 00)
16. Install air intake housing. (WP 0103 00)
17. Install fuel pump. (WP 0094 00)
18. Install cylinder head poppet valve rocker arm covers. (WP 0043 00)
19. Install air inlet collector assembly. (WP 0104 00)
20. Install crankcase breather limiter assembly. (WP 0106 00)
21. Service fresh water cooling system. (WP 0133 00)
22. Install powered section engine hatch. (TM 55-1945-205-24-1-1)
23. Install operators cab. (TM 55-1945-205-24-1-1)
24. Install fresh water cooling system bypass hose. (WP 0148 00)
25. Install intake plenum. (TM 55-1945-205-24-1-1)

26. Install main navigation mast. (TM 55-1945-205-24-1-1)

27. Install SINCGARS antenna. (TM 11-5820-890-10-8)

28. Perform operational check of diesel engine. (TM 55-1945-205-10-1)

END OF WORK PACKAGE

**UNIT LEVEL MAINTENANCE
CAUSEWAY FERRY
FUEL COOLER ZINC ANODE PLUG
REPLACEMENT**

INITIAL SETUP:**Tools**

Tool Kit, General Mechanic's, (Rail and Marine) (Item 131, WP 0188 00)

Materials/Parts

Anode, Zinc
(72582)

PN 23507233

Tape, Antiseize (Item 34, WP 0187 00)

Personnel Required

Engineer 88L

References

TM 55-1945-205-10-1

REMOVE FUEL COOLER ZINC ANODE PLUG

1. Verify MAIN circuit breaker (1) on propulsion module circuit breaker panel A6 is off.

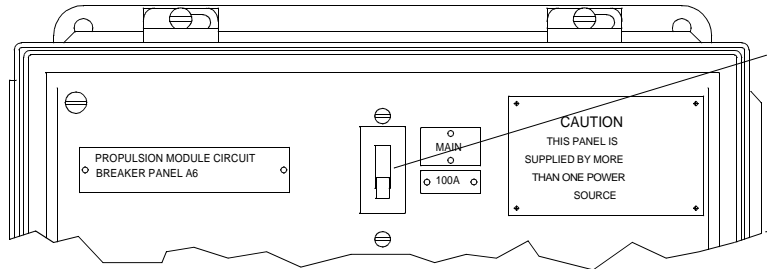

2. Verify butterfly valve (2) on sea chest is closed.

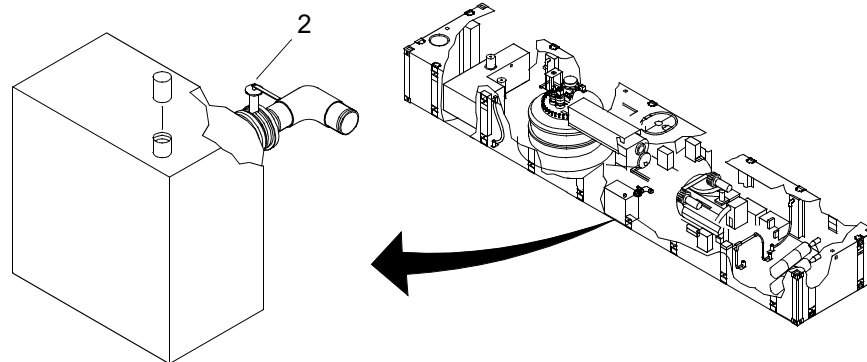

-
3. Remove zinc anode (3) from fuel cooler (4) and discard.

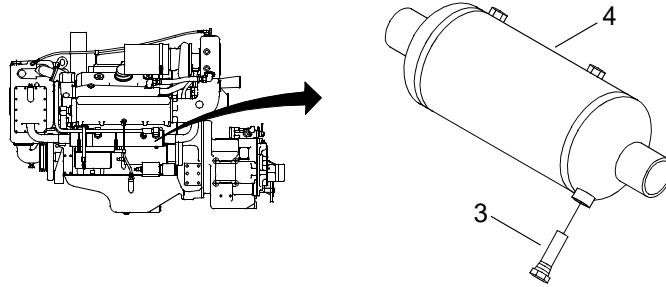

4. Drain raw water into the bilge.

INSTALL FUEL COOLER ZINC ANODE PLUG

1. Wrap new zinc anode (3) threads with antiseize tape.
2. Install zinc anode (3) into fuel cooler (4).
3. Tighten zinc anode (3).
4. Start the engine. (TM 55-1945-205-10-1)
5. Start the bilge pumps to remove raw water from bilge. (TM 55-1945-205-10-1)
6. Stop the engine. (TM 55-1945-205-10-1)

END OF WORK PACKAGE

**UNIT LEVEL MAINTENANCE
CAUSEWAY FERRY
MARINE GEAR COOLER ZINC ANODE PLUG
REPLACEMENT**

INITIAL SETUP:**Tools**

Tool Kit, General Mechanic's (Rail and Marine) (Item 131, WP 0188 00)

Materials/Parts

Anode, Zinc
(72582)

PN 23507233

Tape, Antiseize (Item 34, WP 0187 00)

Personnel Required

Engineer 88L

References

TM 55-1945-205-10-1

REMOVE MARINE GEAR COOLER ZINC ANODE PLUG

1. Verify MAIN circuit breaker (1) on propulsion module circuit breaker panel A6 is off.

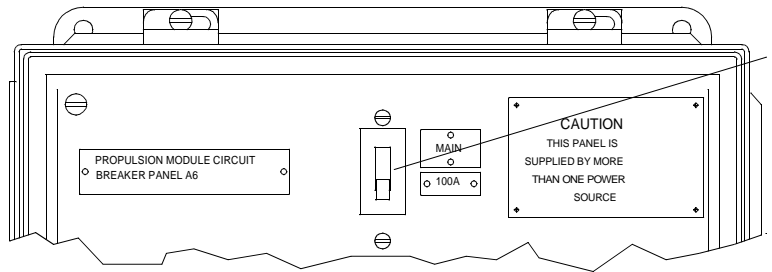

2. Verify butterfly valve (2) on sea chest is off.

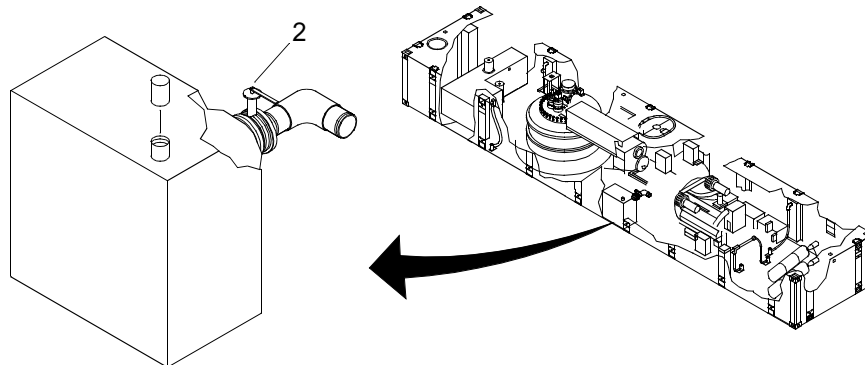

-
3. Remove zinc anode (3) from marine gear cooler (4) and discard.

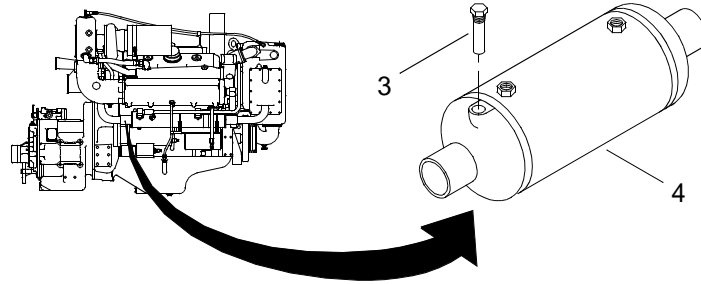

4. Drain raw water into bilge.

INSTALL MARINE GEAR COOLER ZINC ANODE PLUG

1. Wrap new zinc anode (3) threads with antiseize tape.
2. Install zinc anode (3) into marine gear cooler (4).
3. Tighten zinc anode (3).
4. Start engine. (TM 55-1945-205-10-1)
5. Start the bilge pumps to remove raw water from bilge. (TM 55-1945-205-10-1)
6. Stop the engine. (TM 55-1945-205-10-1)

END OF WORK PACKAGE

**UNIT LEVEL MAINTENANCE
CAUSEWAY FERRY
HEAT EXCHANGER ZINC ANODE PLUG
REPLACEMENT**

INITIAL SETUP:**Tools**

Tool Kit, General Mechanic's (Rail and Marine) (Item 131, WP 0188 00)

Materials/Parts

Anode, Zinc
(72582)

PN 8515850

Tape, Antiseize (Item 34, WP 0187 00)

Personnel Required

Engineer 88L

References

TM 55-1945-205-10-1

REMOVE HEAT EXCHANGER ZINC ANODE PLUG

1. Verify MAIN circuit breaker (1) on propulsion module circuit breaker panel A6 is off.

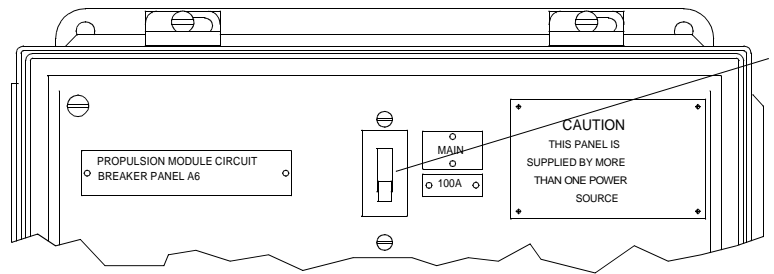

2. Verify butterfly valve (2) on sea chest is off.

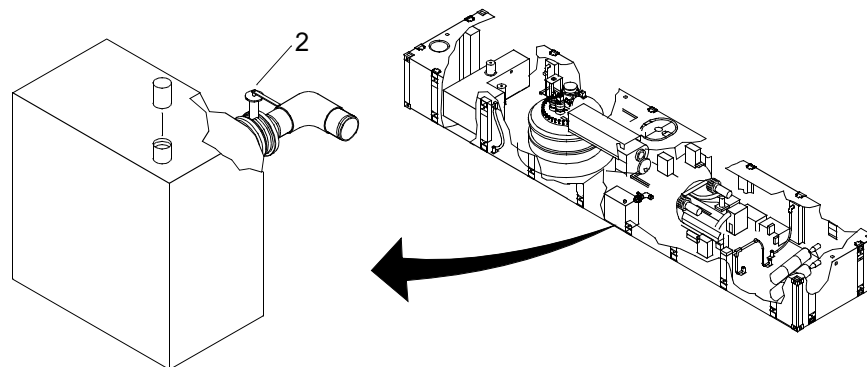

-
3. Remove two support plugs (3) with zinc anodes (4) from heat exchanger (5).

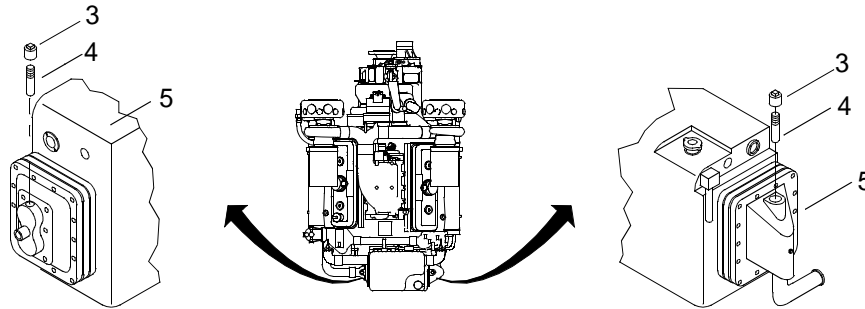

4. Drain raw water into bilge.
5. Separate old zinc anode (4) from support plug (3) and discard zinc anode (4).

INSTALL HEAT EXCHANGER ZINC ANODE PLUG

1. Install new zinc anode (4) into support plug (3)
2. Wrap support plug (3) threads with antiseize tape.
3. Install support plug (3) with zinc anode (4) into heat exchanger (5).
4. Tighten support plug (3).
5. Start engine. (TM 55-1945-205-10-1)
6. Start the bilge pumps to remove raw water from bilge. (TM 55-1945-205-10-1)
7. Stop the engine. (TM 55-1945-205-10-1)

END OF WORK PACKAGE

**UNIT LEVEL MAINTENANCE
CAUSEWAY FERRY
RAW WATER PUMP ZINC ANODE PLUG
REPLACEMENT**

INITIAL SETUP:**Tools**

Tool Kit, General Mechanic's (Rail and Marine) (Item 131, WP 0188 00)

Materials/Parts

Anode, Zinc
(72582)

PN 8517479

Tape, Antiseize (Item 34, WP 0187 00)

Personnel Required

Engineer 88L

References

TM 55-1945-205-10-1

REMOVE RAW WATER PUMP ZINC ANODE PLUG

1. Verify MAIN circuit breaker (1) on propulsion module circuit breaker panel A6 is off.

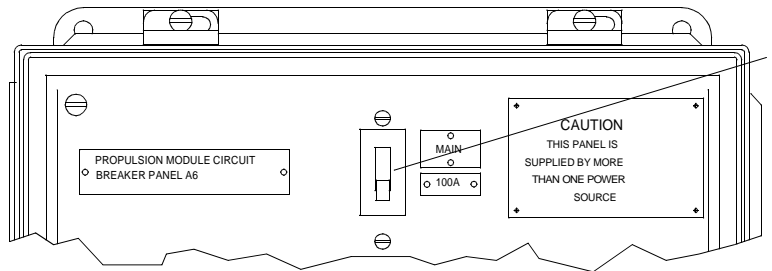

2. Verify butterfly valve (2) on sea chest is off.

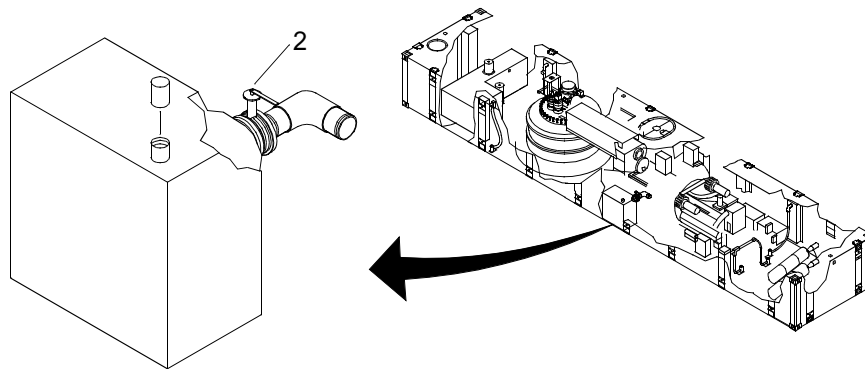

3. Remove zinc anode (3) from raw water pump (4) and discard.

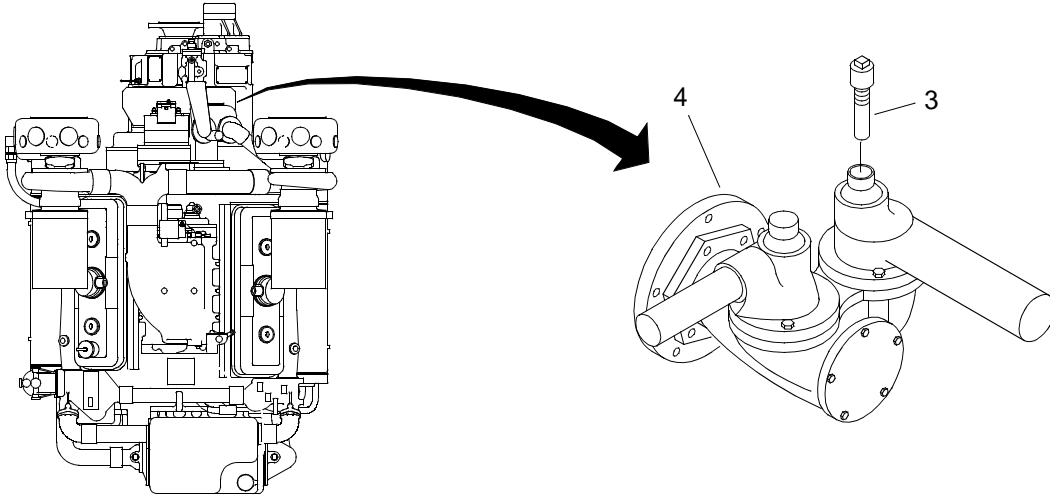

4. Drain raw water into bilge.

INSTALL RAW WATER PUMP ZINC ANODE PLUG

1. Wrap new zinc anode (3) threads with antiseize tape.
2. Install zinc anode (3) into marine raw water pump (4).
3. Tighten zinc anode (3).
4. Start engine. (TM 55-1945-205-10-1)
5. Start the bilge pumps to remove raw water from bilge. (TM 55-1945-205-10-1)
6. Stop the engine. (TM 55-1945-205-10-1)

END OF WORK PACKAGE

**UNIT LEVEL MAINTENANCE
CAUSEWAY FERRY
RAW WATER PUMP
REMOVAL AND INSTALLATION**

INITIAL SETUP:**Tools**

Tool Kit, General Mechanic's (Rail and Marine) (Item 131, WP 0188 00)
Hammer, Hand, (Dead Blow) (Item 59, WP 0188 00)

Materials/Parts

Gasket
(72582)
PN 5112143
Qty 2
Gasket
(72582)
PN 23515145

Personnel Required

Engineer 88L

References

TM 55-1945-205-10-1

REMOVE RAW WATER PUMP

1. Verify butterfly valve (1) on sea chest is off.

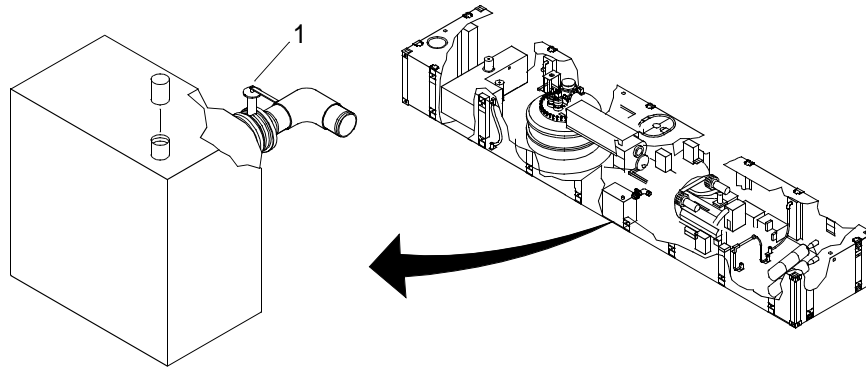

2. Loosen clamps (2) at outlet elbow (3) and pump outlet tube (4).

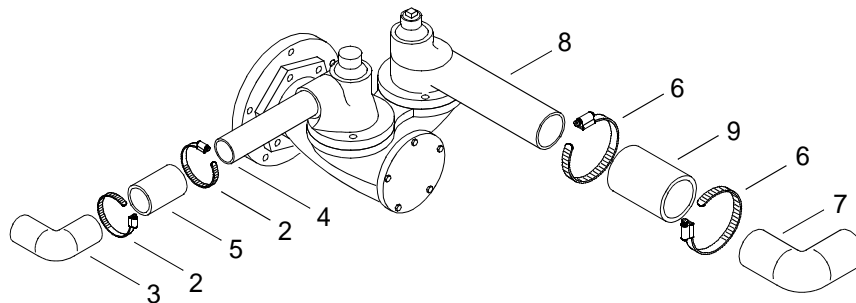

3. Slide hose (5) back along intermediate tube (4).

4. Drain raw water into bilge.
5. Loosen clamps (6) at inlet elbow (7) and pump inlet tube (8).
6. Slide hose (9) back along intermediate tube (8).
7. Drain raw water into bilge.
8. Remove hex head bolts (10) and lock washers (11) from outlet elbow (4) and remove outlet elbow (4) and gasket (12). Discard gasket.

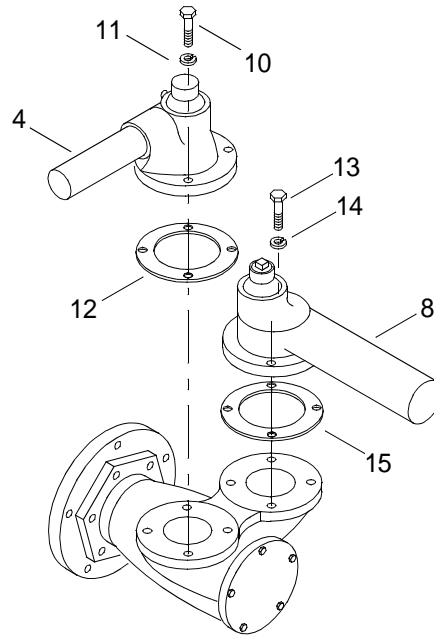

9. Remove hex head bolts (13) and lock washers (14) from inlet tube (8) and remove inlet tube (8) and gasket (15). Discard gasket.
10. Remove hex head bolts (16) and washers (17) securing raw water pump (18) to flywheel housing adaptor (19).

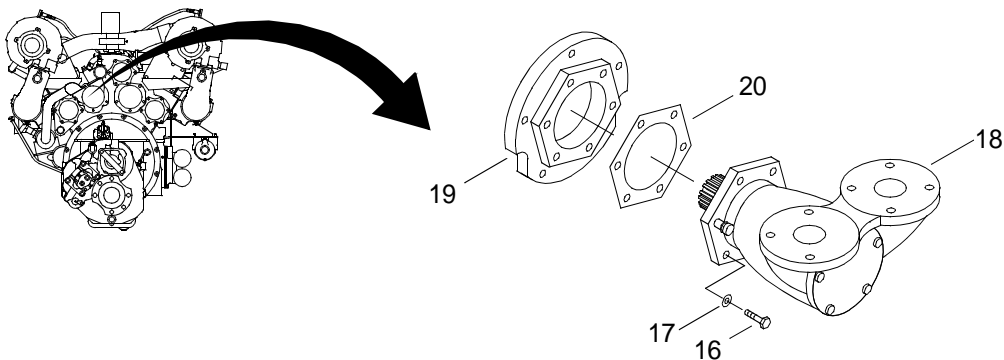

11. Loosen the raw water pump (18) from the flywheel housing adaptor (19) by tapping it with a dead blow hammer.
12. Remove the raw water pump (18) and gasket (20) from the flywheel housing adaptor (19). Discard gasket.

INSTALL RAW WATER PUMP

1. Position raw water pump (18) and new gasket (20) on the flywheel housing adaptor (19).
2. Install hex head bolts (16) and washers (17) securing raw water pump (18), gasket (20) to fly wheel housing adaptor (19).
3. Tighten hex head bolts (16).
4. Position pump tube (8) and new gasket (15) on raw water pump (18).
5. Install hex head bolts (12) and lock washers (13) through inlet tube (8) and gasket (15).
6. Tighten hex head bolts (12).
7. Position outlet elbow (3) and new gasket (12) on raw water pump (18).
8. Install hex head bolts (10) and lock washers (11) through outlet elbow (3) and gasket (15) and into raw water pump (18).

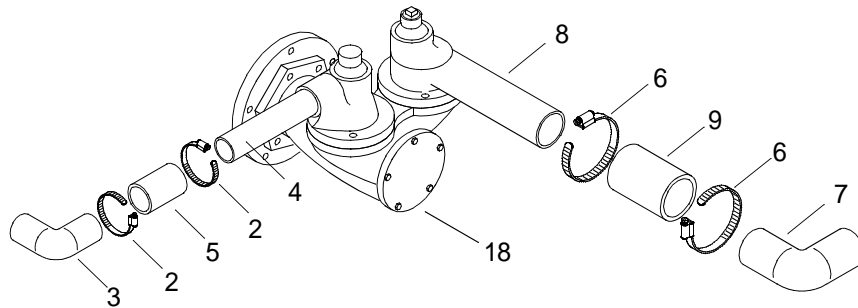

9. Tighten hex head bolts (10).
10. Slide hose (9) over the inlet elbow (7) and inlet tube (8).
11. Position clamps (6) and tighten clamps (6) at inlet elbow (7) and inlet tube (8).
12. Slide hose (5) over the outlet tube (4) and the outlet elbow (3).
13. Position and tighten clamps (2) at outlet elbow (3) and outlet tube (4).
14. Start engine and verify there are no leaks. (TM 55-1945-205-10-1)
15. Start the bilge pumps to remove raw water from bilge. (TM 55-1945-205-10-1)
16. Shut down engine. (TM 55-1945-205-10-1)

END OF WORK PACKAGE

**DIRECT SUPPORT MAINTENANCE
CAUSEWAY FERRY
RAW WATER PUMP
REPAIR**

INITIAL SETUP:**Tools**

Tool Kit, General Mechanic's (Item 130, WP 0188 00)
 Apron, Utility (Item 8, WP 0188 00)
 Gloves, Men's and (Leather Palm) (Item 53, WP 0188 00)
 Goggles, Industrial (Item 54, WP 0188 00)
 Press, Arbor Hand Operated (Item 97, WP 0188 00)
 Caps, Vice, Copper (Item 24, WP 0188 00)
 Puller Set, Mechanical, Gear And Bearing (Item 99, WP 0188 00)
 Wrench, Torque (150-750 in. lbs) (Item 142, WP 0188 00)
 Wrench Set, Socket (3/8 in. sqdr.) (Item 135, WP 0188 00)
 Pliers, Retaining Ring J4646 (Item 95, WP 0188 00)
 Pin, Drift (Item 90, WP 0188 00)

Materials/Parts

Parts Kit, Engine Water Pump
 (72582)
 NSN 2930-01-305-3808
 PN 8927566
 Cloth, Cleaning (Item 13, WP 0187 00)
 Cleaner, Type II (Item 8, WP 0187 00)
 Lumber, Softwood, Dimension (2 in. X 4 in. X 6 ft Min Wooden Blocks) (Item 23, WP 0187 00)
 Qty 2
 Cloth, Abrasive (Item 12, WP 0187 00)
 Fuel, Diesel (Item 19, WP 0187 00)

Personnel Required

Engineer 88L

DISASSEMBLE RAW WATER PUMP

1. Remove five hex head screws (1) from cover (2) and gasket (3).

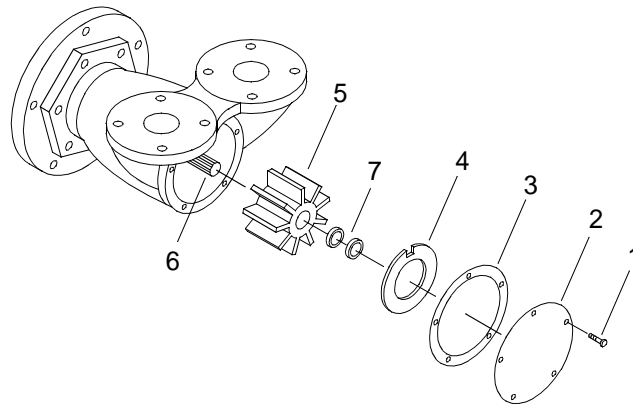

2. Remove cover (2) and gasket (3) and discard gasket.

NOTE

The spline plugs (6) will come out with the impeller (5).

3. Remove plate (4).
4. Using two pliers, grasp a blade on each side of the impeller (5) and pull impeller (5) from shaft (6).
5. Remove spline plugs (7) from impeller (5).
6. Discard spline plugs (7).
7. Using retaining ring pliers, remove snap ring (8).
8. Insert two wires, each bent to a hook at one end, between the housing (9) and shaft seal (10) with the hooks over the edge of the carbon seal (11) and pull the seal assembly (10) from the shaft (6).

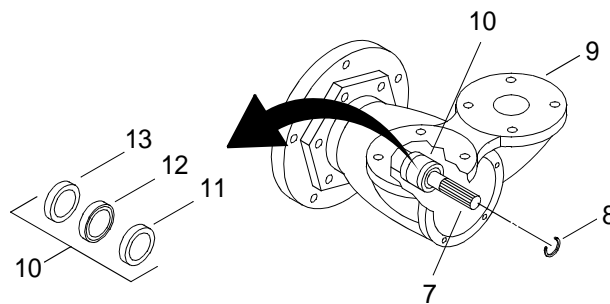

9. Repeat step six to remove seal seat (12) and the gasket (13).
10. Place housing (9) with drive gear (14) in a vice equipped with soft jaw vice caps.

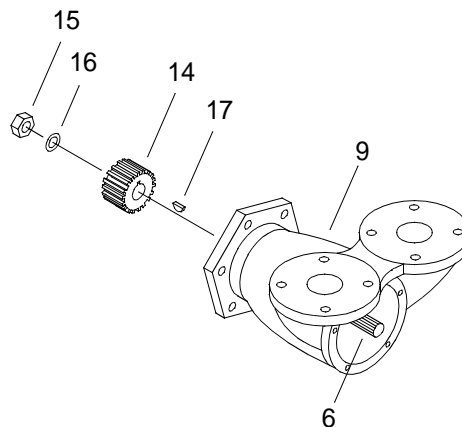

11. Remove hex nut (15) and lock washer (16).
12. Remove the drive gear (14) from the vice.
13. Using puller set, remove drive gear (14) from shaft (6).
14. Remove woodruff key (17) from shaft (6).

15. Support housing (9) on an arbor press with the mounting flange down.

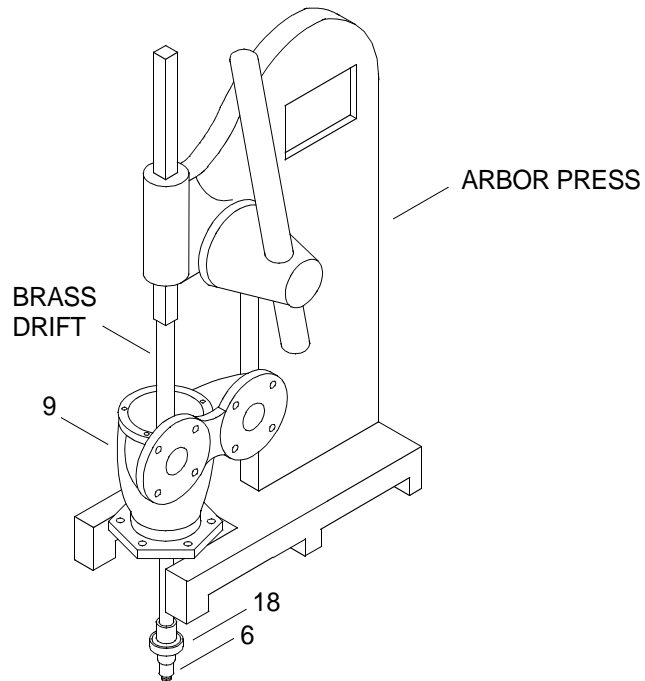

16. Use a brass drift pin between shaft (6) and the arbor press and press out the shaft (6) and bearing (18).

17. Remove slinger (19) from shaft (6).

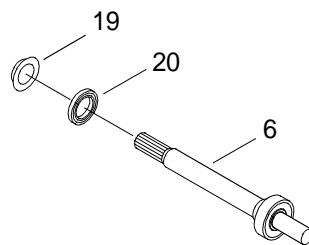

18. Remove the bearing seal (20) from the shaft (6).

19. Using an arbor press, remove bearing (18) from shaft (6).

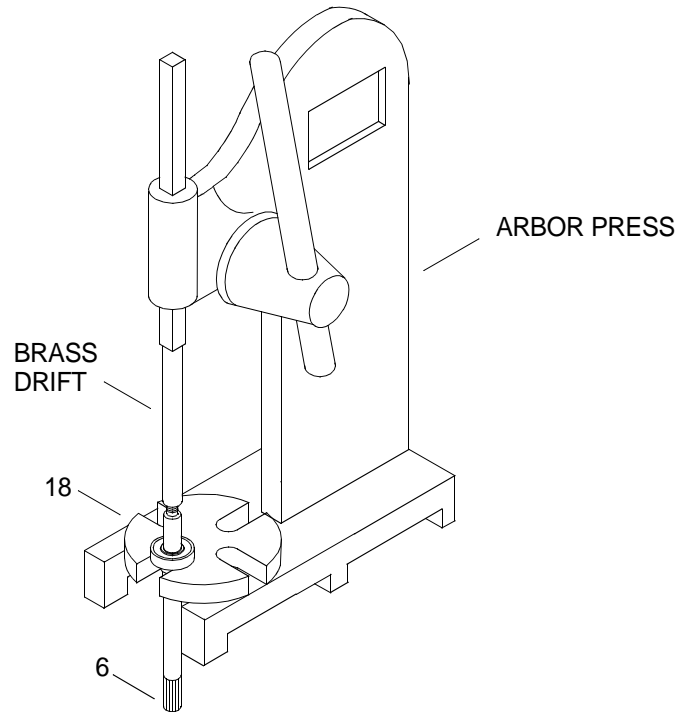

20. Remove slotted screw (21) from cam (22) and remove cam (22).

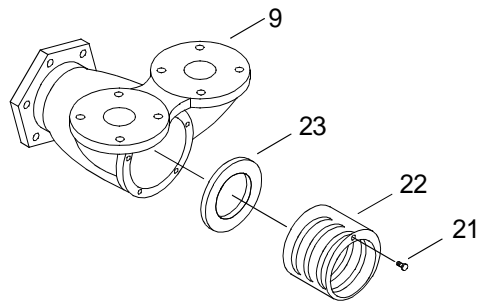

21. Lift the wear plate (23) off of its dowel in housing (9).

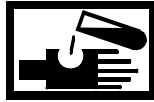
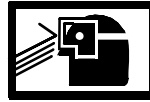
CLEAN RAW WATER PUMP**WARNING****CHEMICAL****EYE PROTECTION****CAUTION**

Do not clean shielded bearing (17) in solvent. Dirt may be washed in and the solvent may not be removed. Failure to comply could result in damage to equipment.

1. Using a clean cloth, wipe bearing (17) clean.

WARNING**CHEMICAL****EYE PROTECTION**

2. Using a clean cloth, clean the exterior of the raw water pump.

INSPECT RAW WATER PUMP

1. Inspect bearing (17) for external damage, replace bearing (17) if damage is found.
2. Hold the inner race and spin the bearing (17) slowly to detect any internal wear or rough spots, replace bearing (17) if damage is found.
3. Inspect all parts for cracks, burring or wear and replace as necessary.

WARNING**CHEMICAL****EYE PROTECTION**

4. Inspect the oil seal contact surfaces on shaft (6) for scratches or grooves, use fine abrasive cloth dipped in diesel fuel to remove scratches.
5. Inspect the impeller (5), make sure the bond between the neoprene and the metal is still good. and make sure the blades do not have a permanent set. Replace the impeller (5) as necessary.
6. Inspect the impeller blades for deformation.
7. Inspect wear plate (23) and remove any burrs from wear plate. If wear is excessive, reverse or replace wear plate.

ASSEMBLE RAW WATER PUMP

1. Install wear plate (23) over the dowel in housing (9).
2. Place the cam (22) in the housing (9) so that the cam (22) is flush with the end of the housing (9).
3. Secure cam (22) with slotted screw (20).
4. Support bearing (18) on lumber.
5. Use an arbor press to install shaft (6) into bearing (18), firmly press against the shoulder of shaft (6).
6. Install bearing seal (20) on shaft (6) with lip facing towards the bearing (18).
7. Place oil slinger (19) on shaft (6).
8. Press shaft (6) with bearing (18) into the counterbore of housing (9) using an arbor press.
9. Install woodruff key (17) onto the shaft (6).
10. Start gear (14) onto shaft (6) and use an arbor press to firmly seat gear (14) against the shoulder of shaft (6).
11. Clamp the gear (14) in a soft jaw vice and install lock washer (16) and hex nut (15).
12. Using a torque wrench and socket set, torque hex nut (15) to 300 - 360 in. lbs (34-41 N-m).
13. Place new gasket (13) and seal seat (12) over shaft (6) and press into position with an arbor press.
14. Install the carbon ring (11).
15. Using retaining ring pliers, install snap ring (8).
16. Compress the impeller blades (5) enough to clear the cam (22) and install impeller (5) onto shaft (6).
17. Install new spline plugs (7) on shaft (6).
18. Rotate impeller (5) several turns in the direction it will turn during operation to seat the blades properly.
19. Install plate (4).
20. Position new gasket (3) and cover (2) in place.
21. Install hex head screws (1).

END OF WORK PACKAGE

**UNIT LEVEL MAINTENANCE
CAUSEWAY FERRY
RAW WATER PUMP SEAL
REPLACEMENT**

INITIAL SETUP:**Tools**

Tool Kit, General Mechanic's (Rail and Marine) (Item 131, WP 0188 00)
Pliers, Retaining Ring (Item 95, WP 0188 00)
Pan, Drain (Item 87, WP 0188 00)

Materials/Parts

Gasket
(72582)
PN 23501648
Assembly, Seal
(72582)
PN 8927573
Ring
(72582)
PN 23501652

Personnel Required

Engineer 88L

References

TM 55-1945-205-10-1

REMOVE RAW WATER PUMP SEAL**NOTE**

The following procedure is typical for the removal and installation of the raw water pump seal.

1. Position drain pan beneath raw water pump (1).

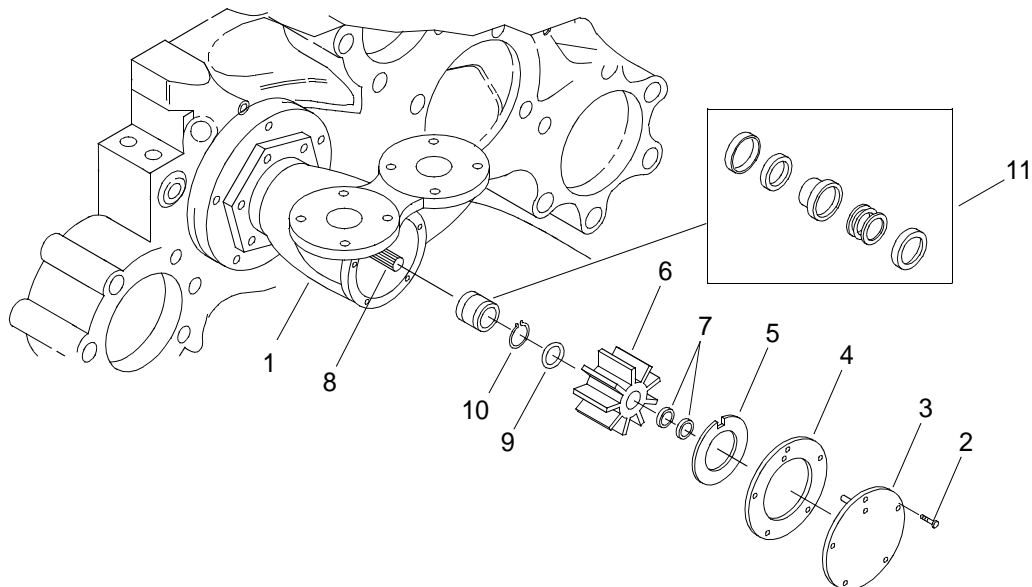

2. Remove five hex head screws (2) securing cover (3).
3. Remove cover (3), gasket (4) and plate (5) from front of raw water pump (1) and allow raw water to drain into drain pan. Discard gasket (4).

NOTE

The spline plug will come out with the impeller during removal.

4. Using two pliers, grasp a blade on each side of the impeller (6) and pull impeller (6) with spline plug (7) from shaft (8).
5. Remove spline plugs (7) from impeller (6). Discard spline plugs.
6. Remove ring (9) from bottom of impeller (6) and discard ring (9).
7. Using snap ring pliers, remove the snap ring (10) securing seal assembly (11) on the shaft (8).
8. Using a scribe, hook beneath the seal assembly (11) and remove the seal assembly (11) from the shaft (8) and discard seal assembly (11).

INSTALL ENGINE RAW WATER PUMP SEAL

1. Position new seal assembly (11) on the shaft (8) and seat firmly inside the raw water pump (1).

NOTE

The seal assembly contains a spring that must be compressed during snap ring installation.

2. Pressing down on the seal assembly, use snap ring pliers to install the snap ring (10) on the shaft (8).
3. Install new ring (9) in bottom of impeller (6).
4. Install impeller (6) onto shaft (8) by rotating and pressing the impeller (6) into the housing of the raw water pump (1).
5. If previously removed, install spline plug (7) into top of impeller (6).

NOTE

Align the dowel pin on the inside of the cover with the hole in the gasket and the notch in the plate during installation.

6. Position plate (5), new gasket (4) and cover (3) on front of raw water pump (1).
7. Install six hex head screws (2) to secure the cover (3) to the raw water pump (1) and tighten screws (2).
8. Perform operational check of diesel engine. (TM 55-1945-205-10-1)

END OF WORK PACKAGE

**DIRECT SUPPORT MAINTENANCE
CAUSEWAY FERRY
EXHAUST MANIFOLD
REPLACEMENT**

INITIAL SETUP:**Tools**

Tool Kit, General Mechanic's (Item 130, WP 0188 00)
Wrench, Torque (150-750 in. lbs) (Item 142, WP 0188 00)
Wrench Set, Socket (3/8 in. sqdr.) (Item 135, WP 0188 00)

Materials/Parts

Exhaust Manifold
(72582)
PN 23511981
Qty 2
Gasket
(72582)
PN 23504186
Qty 4
Gasket
(72582)
PN 5120224
Qty 4
Tape, Antiseize (Item 34, WP 0187 00)

Personnel Required

Engineer 88L

References

TM 55-1945-205-10-1

Equipment Condition

SINGARS Antenna Removed. (TM 11-5820-890-10-8)
Main Navigation Mast Removed. (TM 55-1945-205-24-1-1)
Intake Plenum Assembly Removed. (TM 55-1945-205-24-1-1)
Operators Cab Removed. (TM 55-1945-205-24-1-1)
Propulsion Module Engine Hatch Removed. (TM 55-1945-205-24-1-1)
Engine Cool To Touch.
Crankcase Breather Limiter Removed. (WP 0106 00)
Air Inlet Collector Removed. (WP 0104 00)
Fresh Water Cooling System Drained. (WP 0134 00)
Turbocharger Removed. (WP 0114 00)

REMOVE EXHAUST MANIFOLD**NOTE**

This task is typical for both port and starboard engines.

1. Disconnect the water inlet tube (1) from the exhaust manifold (2).

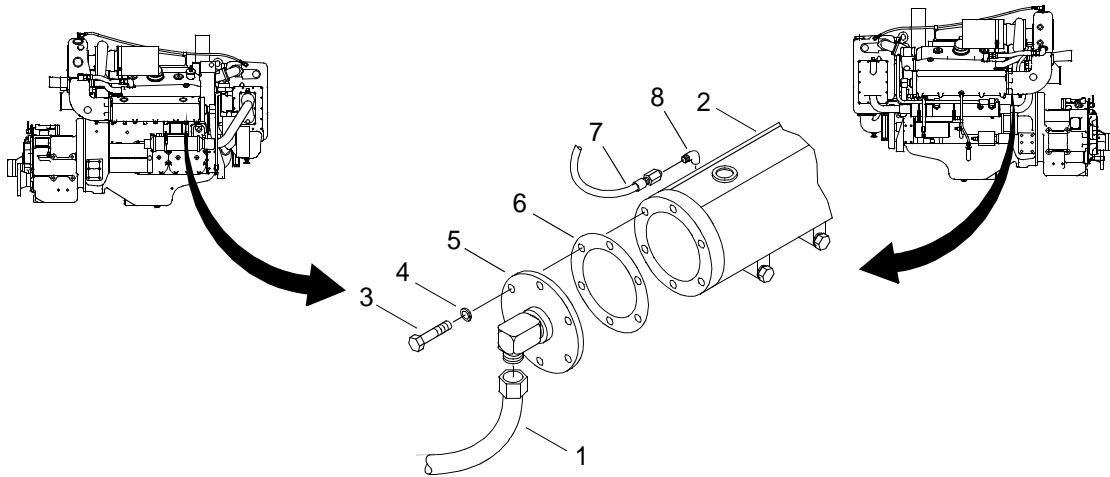

2. Remove six hex head bolts (3) and lock washers (4) from cover (5).
3. Remove cover (5) from manifold (2).
4. Remove gasket (6) from exhaust manifold (2) and discard.
5. Disconnect coolant aspirator line (7) from elbow (8).
6. Remove elbow (8) from manifold (2).
7. Remove six hex nuts (9) and lock washers (10) from studs (11).

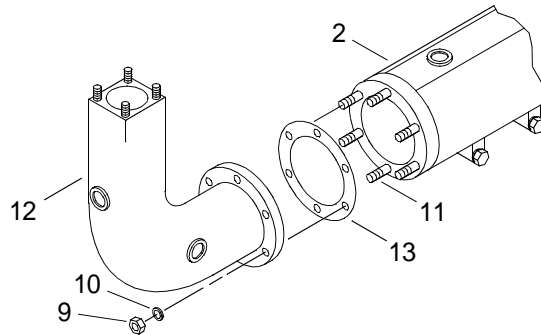

8. Remove the turbocharger flange adaptor (12) from the exhaust manifold (2).
9. Remove gasket (13) from exhaust manifold (2) and discard.

NOTE

Leave the nut and washer on the center stud until all the other nuts and washers have been removed.

10. Remove hex head bolts (15) and beveled washers (16) that secure the exhaust manifold (2) to cylinder head (14).

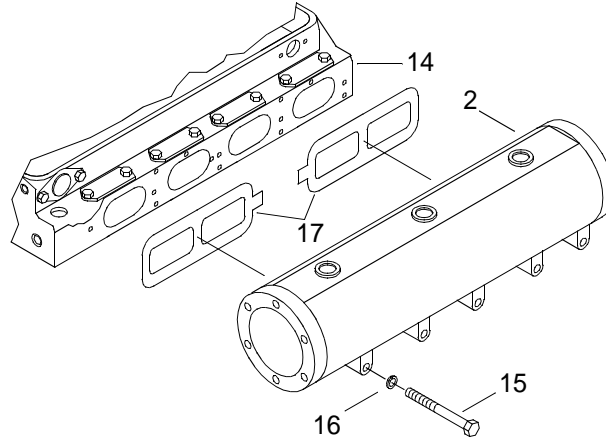

11. Remove the exhaust manifold (2) from the engine.
12. Remove and discard manifold gaskets (17).

INSTALL EXHAUST MANIFOLD

1. Position new manifold gaskets (17) on cylinder head (14).

NOTE

Be sure the locating pads on the exhaust manifold rests on the cylinder block locating pads.

2. Install the exhaust manifold (2) on cylinder head (14).

NOTE

Beveled washers should be set in position so that the outer diameter will rest on the manifold and the crown at the center is next to the nut.

3. Install hex head bolts (15) with beveled washers (16) and secure the exhaust manifold (2) on the cylinder head (14).

NOTE

The exhaust manifold nuts should be tightened from the center of the exhaust manifold outward, alternating towards either end.

4. Using torque wrench and socket set, torque hex head bolts (15) to 360 - 420 in. lbs (41-47 N-m).
5. Install new gasket (13) from exhaust manifold (2).
6. Install the turbocharger flange adaptor (12) on manifold (2).
7. Install six hex nuts (9) and lock washers (10) on studs (11).

8. Wrap elbow (8) threads with antiseize tape.
9. Install elbow (8) on manifold (2).
10. Install coolant aspirator line (7) on elbow (8).
11. Position new gasket (6) on exhaust manifold (2).
12. Install cover plate (5) from exhaust manifold (2).
13. Install six hex head bolts (3) and lock washers (4) in cover (5).
14. Connect the water inlet tube (1) to exhaust manifold (2).
15. Service the fresh water cooling system. (WP 0133 00)
16. Install the turbochargers. (WP 0114 00)
17. Install air inlet collector. (WP 0104 00)
18. Install crankcase breather limiter. (WP 0106 00)
19. Install the operators cab. (TM 55-1945-205-24-1-1)
20. Install the intake plenum assembly. (TM 55-1945-205-24-1-1)
21. Install the main navigation mast. (TM 55-1945-205-24-1-1)
22. Install the SINCGARS antenna. (TM 11-5820-890-10-8)
23. Perform operational check of diesel engine. (TM 55-1945-205-10-1)

END OF WORK PACKAGE

**UNIT LEVEL MAINTENANCE
CAUSEWAY FERRY
MARINE GEAR OIL COOLER MOUNTING BRACKET
REPLACEMENT**

INITIAL SETUP:**Tools**

Tool Kit, General Mechanic's (Rail and Marine) (Item 131, WP 0188 00)

Materials/Parts

Bracket, Mounting
(72582)
PN 23504757

Personnel Required

Engineer 88L

References

TM 55-1945-205-10-1

Equipment Condition

Marine Gear Oil Cooler Removed. (TM 55-1945-205-24-1-3)

REMOVE THE MOUNTING BRACKET

1. Remove two cap screws (1) and lock washers (2) from mounting bracket (3).

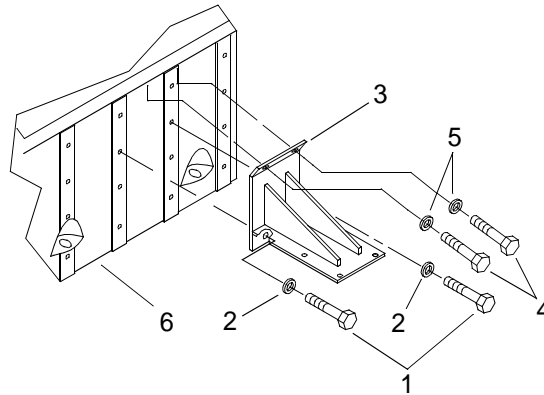

2. Remove two cap screws (4) and lock washers (5) from mounting bracket (3).
3. Remove mounting bracket (3) from engine (6) and discard.

INSTALL THE MOUNTING BRACKET

1. Position new bracket (3) on engine (6).
2. Install two cap screws (4) and lock washers (5) on mounting bracket (3).
3. Install two cap screws (1) and lock washers (2) on mounting bracket (3).

4. Tighten cap screws (1 and 4).
5. Install marine gear oil cooler. (TM 55-1945-205-24-1-3)
6. Perform operational check of diesel engine. (TM 55-1945-205-10-1)

END OF WORK PACKAGE

**UNIT LEVEL MAINTENANCE
CAUSEWAY FERRY
ELECTRICAL SYSTEM NORMAL STOP PUSH BUTTON
REPLACEMENT**

INITIAL SETUP:

Tools

Tool Kit, General Mechanic's (Rail and Marine) (Item 131, WP 0188 00)

Materials/Parts

Push Button
(72582)
PN 1SD41630

Personnel Required

Engineer 88L

References

TM 55-1945-205-10-1

REMOVE THE NORMAL STOP BUTTON

1. Verify MAIN circuit breaker (1) on propulsion module circuit breaker panel A6 is off.

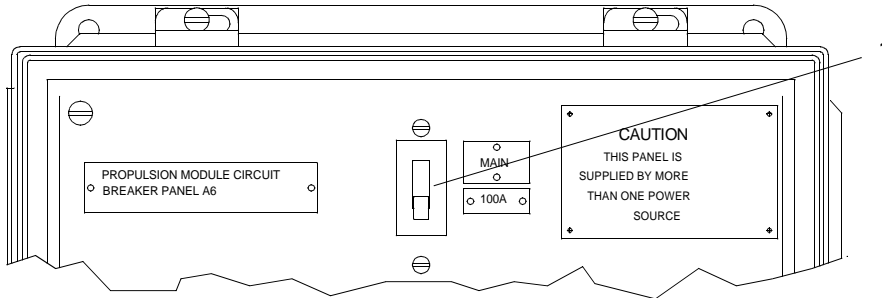

2. Tag and disconnect two wires (2) from push button (3).

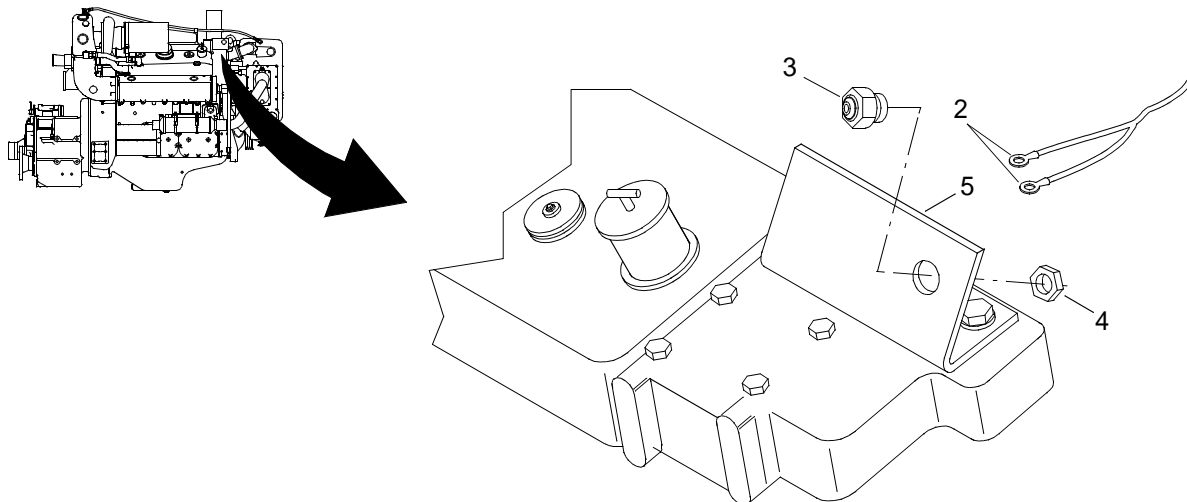

3. Remove hex nut (4) from back side of push button (3).

4. Remove push button (3) from bracket (5) and discard.

INSTALL THE NORMAL STOP BUTTON

1. Install new push button (3) on bracket (5).
2. Install hex nut (4) on the back side of push button (3).
3. Tighten nut (4).
4. Connect two wires (2) on push button (3).
5. Remove wires from wires (2).
6. Perform operational check of diesel engine. (TM 55-1945-205-10-1)

END OF WORK PACKAGE

**UNIT LEVEL MAINTENANCE
CAUSEWAY FERRY
ELECTRICAL SYSTEM NORMAL STOP PUSH BUTTON
MOUNTING BRACKET
REPLACEMENT**

INITIAL SETUP:**Tools**

Tool Kit, General Mechanic's (Rail and Marine) (Item 131, WP 0188 00)

Materials/Parts

Bracket
(72582)
PN 1SD31814
Plate, Legend
(72582)
PN 1SD41640

Personnel Required

Engineer 88L

References

TM 55-1945-205-10-1

Equipment Condition

Electrical System Normal Stop Push Button Removed. (WP 0165 00)

REMOVE MOUNTING BRACKET

1. Remove two cap screws (1) and lock washers (2) securing bracket (3) to thermostat housing (4).

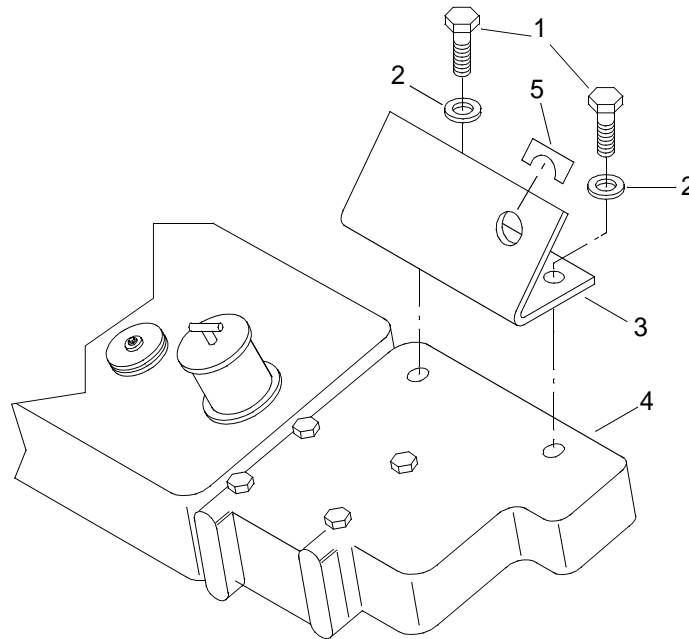

2. Remove bracket (3) from thermostat housing (4) and discard.

INSTALL MOUNTING BRACKET

1. Install new mounting bracket (3) on thermostat housing (4).
2. Install cap screws (1) and lock washers (2) on mounting bracket (3).
3. Tighten cap screws (1).
4. Install new (adhesive backed) legend plate (5) on mounting bracket (3).
5. Install electrical system normal stop push button. (WP 0165 00)
6. Perform operational check of diesel engine. (TM 55-1945-205-10-1)

END OF WORK PACKAGE

**UNIT LEVEL MAINTENANCE
CAUSEWAY FERRY
ELECTRICAL SYSTEM HOUR METER
REPLACEMENT**

INITIAL SETUP:**Tools**

Tool Kit, General Mechanic's (Rail and Marine) (Item 131, WP 0188 00)

Materials/Parts

Hour Meter
(72582)
PN 1SD41621

Personnel Required

Engineer 88L

References

TM 55-1945-205-10-1

REMOVE ELECTRICAL SYSTEM HOUR METER

1. Verify MAIN circuit breaker (1) on propulsion module circuit breaker panel A6 is off.

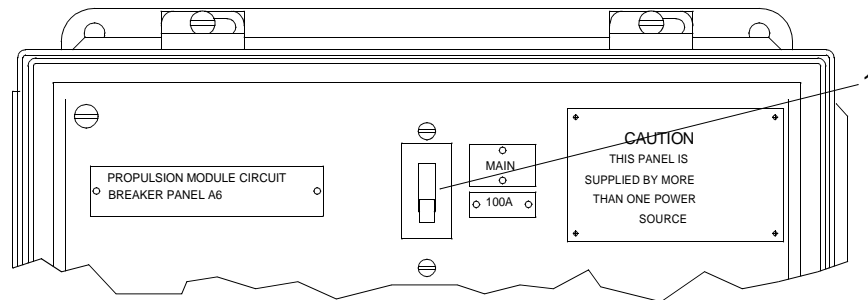

2. Tag and disconnect two wires (2) from hour meter (3).

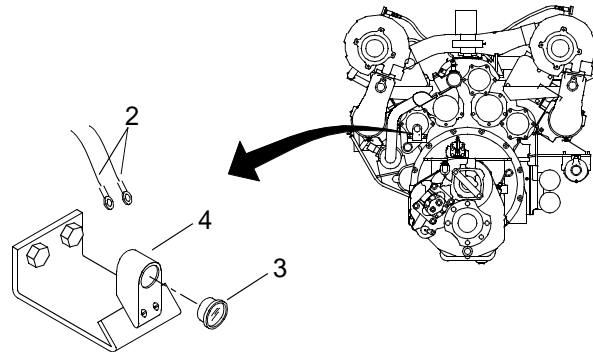

3. Push hour meter (3) out of mounting bracket (4).

INSTALL THE HOUR METER

1. Position new hour meter (3) on bracket (4).
2. Using both thumbs on the steel rim of hour meter (3), press hour meter into mounting bracket (4).
3. Connect two wires (2) on hour meter (3).
4. Remove tags from wires (2).
5. Perform operational check of diesel engine. (TM 55-1945-205-10-1)

END OF WORK PACKAGE

**UNIT LEVEL MAINTENANCE
CAUSEWAY FERRY
ELECTRICAL SYSTEM HOUR METER MOUNTING BRACKET
REPLACEMENT**

INITIAL SETUP:**Tools**

Tool Kit, General Mechanic's (Rail and Marine) (Item 131, WP 0188 00)

Materials/Parts

Bracket
(72582)
PN 1SD41620
Bracket
(72582)
PN 1SD31870

Personnel Required

Engineer 88L

References

TM 55-1945-205-10-1

Equipment Condition

Electrical System Hour Meter Removed. (WP 0167 00)

REMOVE ELECTRICAL SYSTEM MOUNTING BRACKETS

1. Remove two pan head screws (1) from hour meter mounting bracket (2).

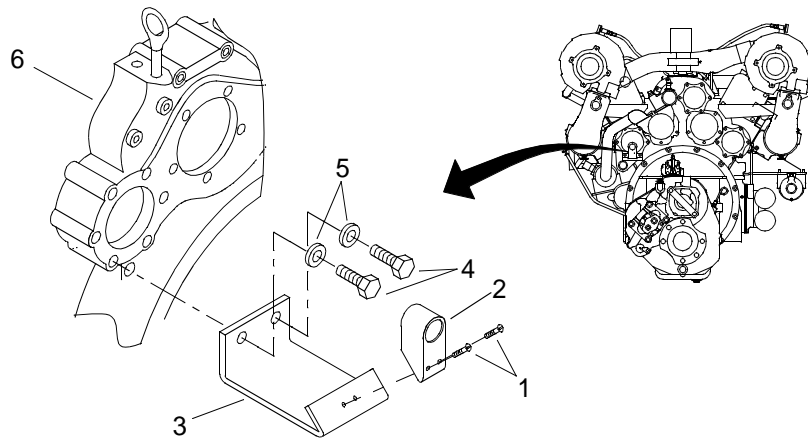

2. Remove bracket (2) from bracket (3) and discard.
3. Remove two cap screws (4) and lock washers (5) from bracket (3)
4. Remove bracket (3) from flywheel housing (6) and discard.

INSTALL THE MOUNTING BRACKETS

1. Position new bracket (3) on flywheel housing (6).
2. Install two cap screws (4) and lock washers (5) on bracket (3).
3. Tighten cap screws (4).
4. Position new hour meter bracket (2) on bracket (3).
5. Install two pan head screws (1) on mounting bracket (2).
6. Tighten cap screws (4).
7. Install electrical system hour meter. (WP 0167 00)
8. Perform operational check of diesel engine. (TM 55-1945-205-10-1)

END OF WORK PACKAGE

**UNIT LEVEL MAINTENANCE
CAUSEWAY FERRY
STARTER RELAY
REPLACEMENT**

INITIAL SETUP:**Tools**

Tool Kit, General Mechanic's (Rail and Marine) (Item 131, WP 0188 00)

Materials/Parts

Relay, Engine Starter
(72582)
PN 1SD41629

Personnel Required

Engineer 88L

References

TM 55-1945-205-10-1

REMOVE STARTER RELAY

WARNING

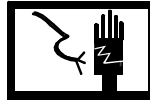

ELECTRICAL

1. Verify MAIN circuit breaker (1) on the propulsion module circuit breaker panel A6 is off.

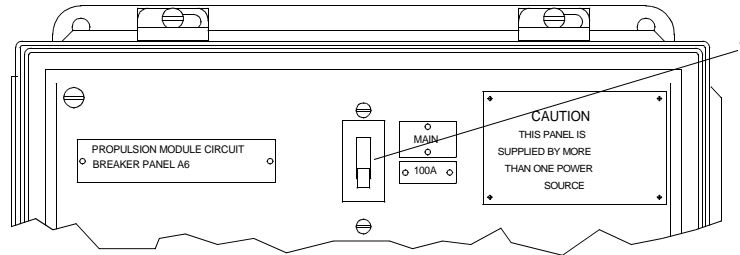

- Lift up and slide back four insulators (1) from starter relay terminals (2).

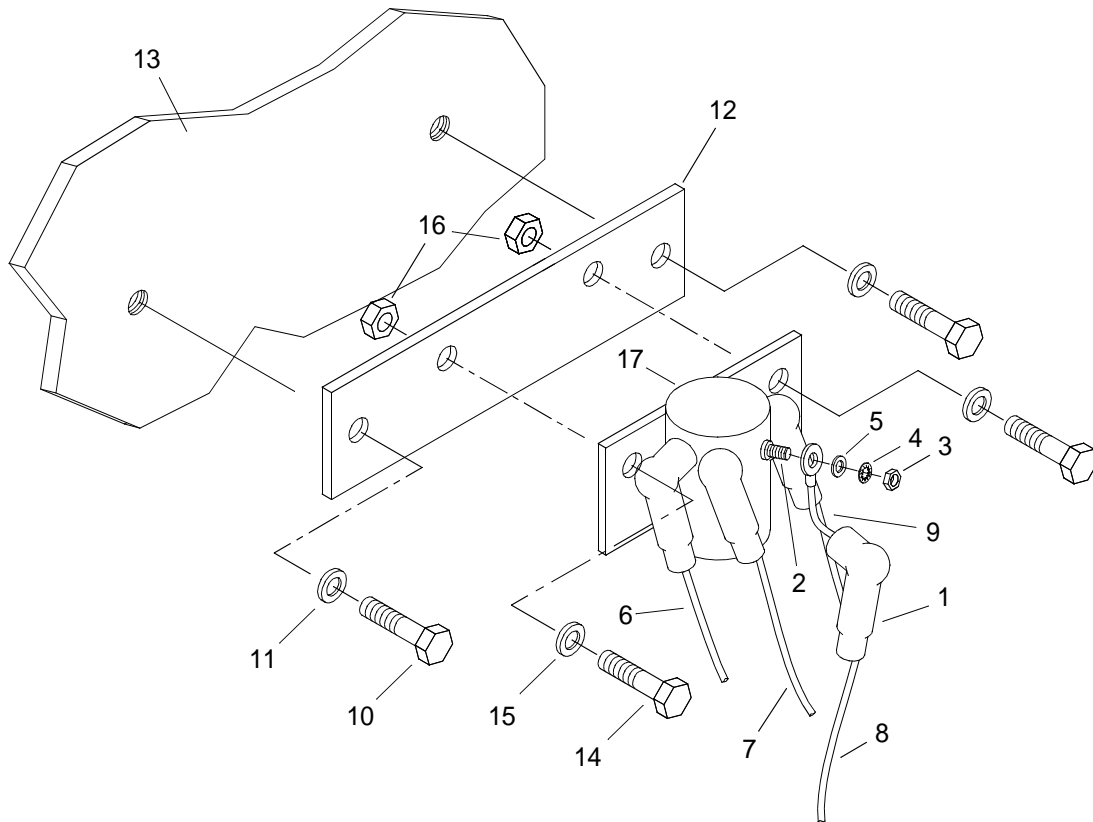

- Remove four nuts (3), lock washers (4) and washers (5) from starter relay terminals (2).
- Tag four wires (6, 7, 8 and 9).
- Remove four wires (6, 7, 8 and 9) from starter relay terminals (2).
- Remove two hex bolts (10) and lock washers (11) holding mounting bracket (12) to engine block (13).
- Remove two bolts (14), lock washers (15) and nuts (16) from starter relay (17) and mounting bracket (12).
- Remove starter relay (17) and discard.

INSTALL STARTER RELAY

- Install two nuts (16), lock washers (15) and bolts (14) to new starter relay (17) and mounting bracket (12).
- Install two lock washers (11) and hex bolts (10) to mounting bracket (12) and engine block (13).
- Connect four wires (6, 7, 8 and 9) to starter relay terminals (2).
- Install four washers (5), lock washers (4) and nuts (3) to starter relay terminals (2).
- Tighten nuts.
- Slide four insulators (1) over starter relay terminals (2).
- Perform operational check of diesel engine. (TM 55-1945-205-10-1)

END OF WORK PACKAGE

**UNIT LEVEL MAINTENANCE
CAUSEWAY FERRY
STARTING MOTOR
REPLACEMENT**

INITIAL SETUP:**Tools**

Tool Kit, General Mechanic's (Rail and Marine) (Item 131, WP 0188 00)
 Wrench, Torque, 0-175 ft lbs (Item 138, WP 0188 00)
 Wrench, Torque, 0-75 in. lbs (Item 140, WP 0188 00)
 Wrench, Torque (150-750 in. lbs) (Item 142, WP 0188 00)
 Wrench Set, Socket (3/8 in. sqdr.) (Item 135, WP 0188 00)

Materials/Parts

Starter, Engine, Electrical
 (72582)
 NSN 2920-00-905-1486
 PN 1990269
 Gasket
 (72582)
 NSN 533200-980-1546
 PN 5130995
 Rags, Wiping (Item 28, WP 0187 00)
 Tape, Electrical Insulation (Item 35, WP 0187 00)

Personnel Required

Engineer 88L

References

TM 55-1945-205-10-1

Equipment Condition

Engine Cool To Touch.
 Powered Section Main Batteries Negative Terminal Leads Removed. (TM 55-1945-205-24-1-1)

REMOVE STARTING MOTOR**NOTE**

This task is typical for the replacement of starter assembly on both port and starboard engines.

1. Remove nut (1) securing starting motor solenoid wires (2).

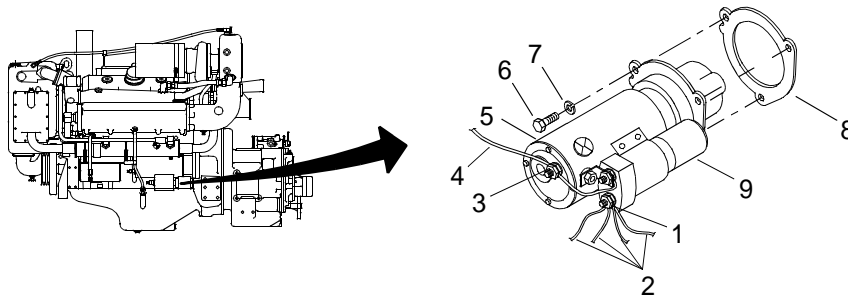

2. Tag and remove wires (2).

3. Remove nut (3) connecting negative wire (4) to starter motor (5) and remove wire (4).
4. Support starting motor (5) and remove three bolts (6) and three lock washers (7) attaching starting motor (5) to flywheel housing.
5. Remove starting motor (5).
6. Remove gasket (8) and discard.
7. Clean mating surface with clean, dry wiping rags and, if necessary, a putty knife may be used.

NOTE

Ensure mating surfaces are clean.

8. Inspect flywheel for missing or damaged teeth. Replace damaged parts. (WP 0069 00)

INSTALL STARTING MOTOR

1. Place new gasket (8) on replacement starting motor (5).
2. Align mounting holes on starting motor (5) with mounting holes on flywheel housing.

CAUTION

**DO not pinch or crush electrical wires between starting motor and flywheel housing.
Damage to cables may occur and prevent starter from operating correctly.**

3. Install three bolts (6) and lock washers (7) into mounting holes of starting motor (5).
4. Using a torque wrench, torque three bolts (6) to a torque value of 137 - 147 ft lbs (186-199 N-m).
5. Attach starting motor negative lead (4) to starting motor (5).
6. Install starting motor cable lead nut (3).
7. Using a torque wrench and socket set, torque nut (3) to 240 - 300 in. lbs (27-34 N-m).
8. Verify electrical connections are clean and not damaged.
9. Attach solenoid switch leads (2) to solenoid switch (9).
10. Install nut (1).
11. Using a torque wrench and socket set, tighten nut (1) to 16 - 30 in. lbs (2-3.5 N-m).
12. Install powered section main battery negative terminal leads. (TM 55-1945-205-24-3-1)
13. Perform operational check of diesel engine. (TM 55-1945-205-10-3)

END OF WORK PACKAGE

**UNIT LEVEL MAINTENANCE
CAUSEWAY FERRY
COLD PACK STARTING AID
REPLACEMENT**

INITIAL SETUP:**Tools**

Tool Kit, General Mechanic's (Rail and Marine) (Item 131, WP 0188 00)
 Gloves, Chemical (Item 52, WP 0188 00)
 Goggles, Industrial (Item 54, WP 0188 00)
 Respirator, Air Filtering (Item 109, WP 0188 00)
 Wrench, Torque (0-75 in. lbs) (Item 140, WP 0188 00)

Materials/Parts

Parts Kit, Ether, Starting Aid
 (53203)
 NSN 2910-01-225-2249
 PN 64017
 Rags, Wiping (Item 28, WP 0187 00)

Personnel Required

Engineer 88L

References

TM 55-1945-205-10-1

REMOVE COLD PACK STARTING AID (CYLINDER)

WARNING



EXPLOSION



EYE PROTECTION



POISON



VAPOR

Cylinder contents are both toxic and extremely flammable. A fire extinguisher must be present while replacing the cylinder. Failure to comply can result in serious injury or death to personnel.

Cylinder contains ethyl ether and is under extremely high pressure. Store in a cool, dry place. Do not incinerate, puncture or attempt to remove cores. Failure to comply can result in serious injury or death to personnel.

NOTE

The following procedure is typical for both port and starboard engines.

1. Prior to removal, use a wiping rag to clean any dirt from cylinder (1) and valve to prevent contaminants from entering and clogging the valve (2).

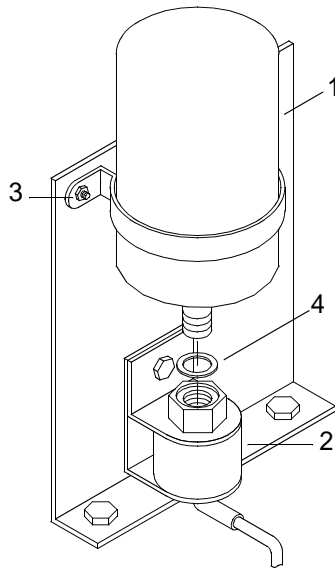

- Loosen cylinder clamp nuts (3).

WARNING



VAPOR



EYE PROTECTION

- Remove cylinder (1) by turning it counterclockwise.
- Remove valve gasket (4) from the valve (2) and discard.

INSTALL COLD PAC STARTING AID (CYLINDER)

CAUTION

During the process of manufacturing the cylinder, there is a small amount of particulate residue left in the cylinder. Allow the cylinder contents to settle approximately 15 to 20 minutes before the system is operated. Failure to allow this settling often causes premature clogging of the system and necessitates cleaning or replacement of the valve's metering orifice filter.

NOTE

Replacement cylinders have a new valve gasket inside the thread protecting white cap on the cylinder.

- Install a new valve gasket (4) in valve (2).
- Install new cylinder (1) by turning clockwise into the valve (2) until the cylinder contacts the valve gasket.

CAUTION

Do not overtighten the cylinder. Failure to comply could damage the valve or the gasket.

3. Tighten cylinder (1) an additional 1 ½ turns.
4. Tighten cylinder clamp nut (3).
5. Using a torque wrench, torque nut (3) to 45 in. lbs (5 N-m).
6. Perform operational check of diesel engine. (TM 55-1945-205-10-1)

END OF WORK PACKAGE

**UNIT LEVEL MAINTENANCE
CAUSEWAY FERRY
COLD START TEMPERATURE SWITCH
REPLACEMENT**

INITIAL SETUP:**Tools**

Tool Kit, General Mechanic's (Rail and Marine) (Item 131, WP 0188 00)

Materials/Parts

Switch, Engine Temperature Automotive
(72582)
NSN 2990-01-242-2992
PN 300789

Personnel Required

Engineer 88L

References

TM 55-1945-205-10-1

Equipment Condition

Engine Cool To Touch.

REMOVE ENGINE COLD START TEMPERATURE SWITCH**NOTE**

The following procedure is typical for both port and starboard engines.

1. Verify MAIN circuit breaker (1) on propulsion module circuit breaker panel A6 is off.

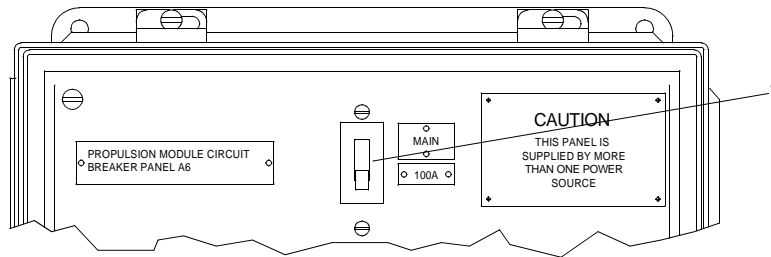

2. Tag and disconnect the cold start temperature switch (2) wire.

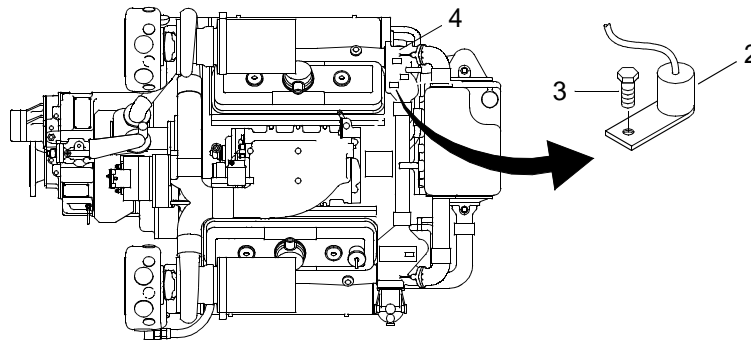

3. Remove hex head bolt (3) securing the cold start temperature switch (2) to the portside thermostat housing (4).

4. Remove the cold start temperature switch (2) and discard.

INSTALL ENGINE COLD START TEMPERATURE SWITCH

1. Position new cold start temperature switch (2) on the portside thermostat housing (4).
2. Install hex head bolt (3) to secure the cold start temperature switch (2) to the portside thermostat housing (4).
Tighten hex head bolt (3).
3. Connect wire and remove tag.
4. Perform operational check of diesel engine. (TM 55-1945-205-10-1)

END OF WORK PACKAGE

**UNIT LEVEL MAINTENANCE
CAUSEWAY FERRY
TACHOMETER SENDING UNIT
REPLACEMENT**

INITIAL SETUP:**Tools**

Tool Kit, General Mechanic's (Rail and Marine) (Item 131 WP 0188 00)

Materials/Parts

Generator, Signal
(72582)
PN 1SD41618

Personnel Required

Engineer 88L

References

TM 55-1945-205-10-1

REMOVE TACHOMETER SENDING UNIT

1. Verify MAIN circuit breaker (1) on propulsion module circuit breaker A6 is off.

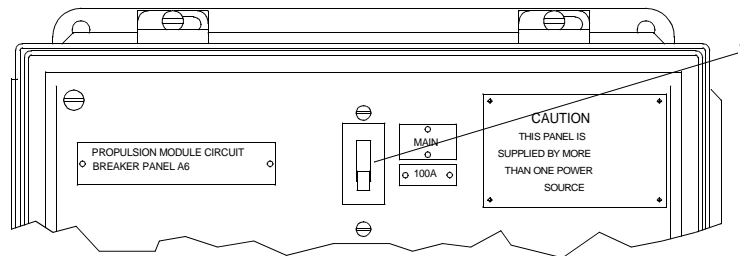

2. Tag and disconnect two flat spade electrical connectors (2 and 3).

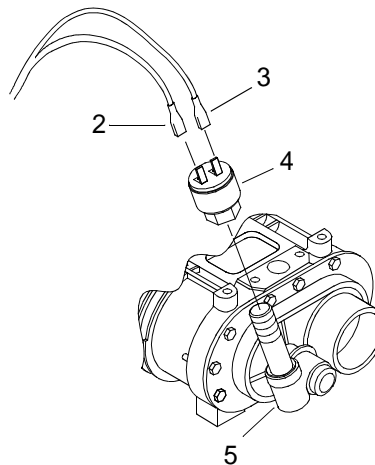

3. Remove and discard tachometer sending unit (4) from the tachometer drive adaptor (5).

INSTALL TACHOMETER SENDING UNIT

1. Install new tachometer sending unit (4) onto the tachometer drive adaptor (5).
2. Connect two flat spade electrical connectors (2 and 3) as tagged.
3. Perform operational check of diesel engine. (TM 55-1945-205-10-1)

END OF WORK PACKAGE

**DIRECT SUPPORT MAINTENANCE
CAUSEWAY FERRY
TACHOMETER DRIVE
REPLACEMENT**

INITIAL SETUP:**Tools**

Tool Kit, General Mechanic's (Item 130, WP 0188 00)
Goggles, Industrial (Item 54, WP 0188 00)
Gloves, Chemical (Item 52, WP 0188 00)

Materials/Parts

Adaptor, Speedometer-Tachometer Drive
(72582)
NSN 6680-01-351-1149
PN 5148380
Gasket
(72582)
NSN 5330-00-198-7953
PN 5136678
Lubricating Oil, Engine (Item 25, WP 0187 00)

Personnel Required

Engineer 88L

References

TM 55-1945-205-10-1

Equipment Condition

SINGARS Antenna Removed. (TM 11-5820-890-10-8)
Main Navigation Mast Removed. (TM 55-1945-205-24-1-1)
Intake Plenum Assembly Removed. (TM 55-1945-205-24-1-1)
Operators Cab Removed. (TM 55-1945-205-24-1-1)
Engine Cool To Touch
Engine Tachometer Sending Unit Removed (WP 0173 00)

REMOVE TACHOMETER DRIVE

1. Loosen jam nut (1).

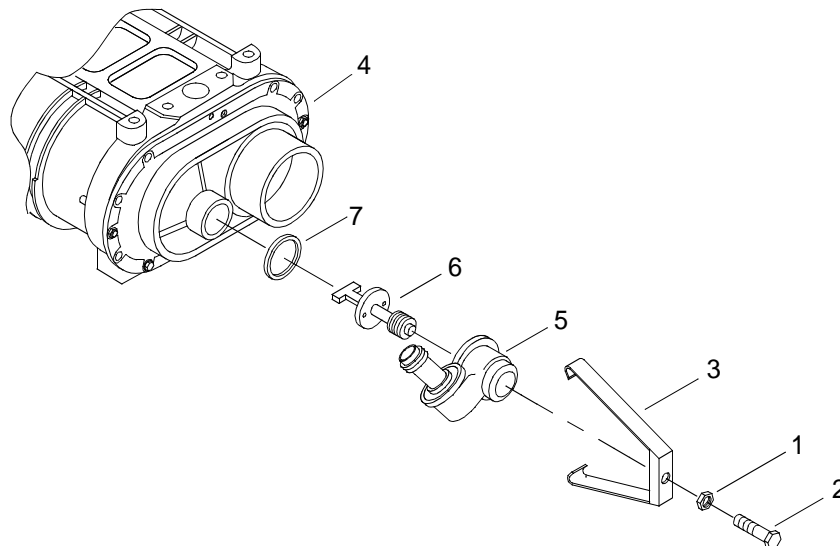

2. Loosen bolt (2).
3. Remove clamp (3) from blower cover (4).
4. Remove housing assembly (5).
5. Remove tachometer drive (6).
6. Remove gasket (7) from blower cover (4) and discard.

INSTALL TACHOMETER DRIVE

WARNING



CHEMICAL

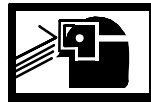

EYE PROTECTION

1. Apply a thin coat of lubricating oil to threads of tachometer drive (6).
2. Install tachometer drive (6) in housing assembly (5).
3. Install new gasket (7).

CAUTION

Make sure tachometer drive lines up with slot of machine screw on blower drive gear. Failure to comply could cause damage to blower and tachometer drive.

4. Install tachometer drive (6) and housing assembly (5) on blower cover (4).
5. Install clamp (3) onto blower cover (4).
6. Tighten bolt (2).
7. Tighten jam nut (1).
8. Install tachometer sending unit. (WP 0173 00)
9. Install the operators cab. (TM 55-1945-205-24-1-1)
10. Install the intake plenum assembly. (TM 55-1945-205-24-1-1)
11. Install the main navigation mast. (TM 55-1945-205-24-1-1)
12. Install the SINCGARS antenna. (TM 11-5820-890-10-8)
13. Perform operational check of diesel engine. (TM 55-1945-205-10-1)

END OF WORK PACKAGE

**GENERAL SUPPORT MAINTENANCE
CAUSEWAY FERRY
OVERSPEED GOVERNOR
REPLACEMENT AND ADJUSTMENT**

INITIAL SETUP:**Test Equipment**

- Multimeter (Item 84, WP 0188 00)
- Power Supply Assembly (Item 96, WP 0188 00)
- Generator, Function, Electronic Test (Item 51, WP 0188 00)
- Counter, Electronic, Digital Readout (Item 30, WP 0188 00)

Tools

- Tool Kit, General Mechanic's (Item 130, WP 0188 00)

Personnel Required

- Engineer 88L

References

- TM 55-1945-205-10-1
-

REMOVE THE OVERSPEED GOVERNOR

1. Verify MAIN circuit breaker (1) on propulsion module circuit breaker panel A6 is off.

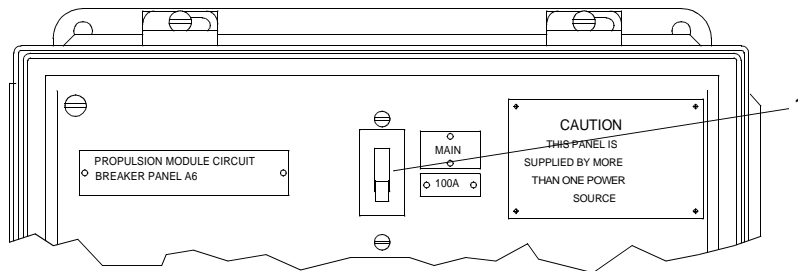

2. Remove two screws (2) and retainer clips (3) securing the overspeed governor box cover (4).

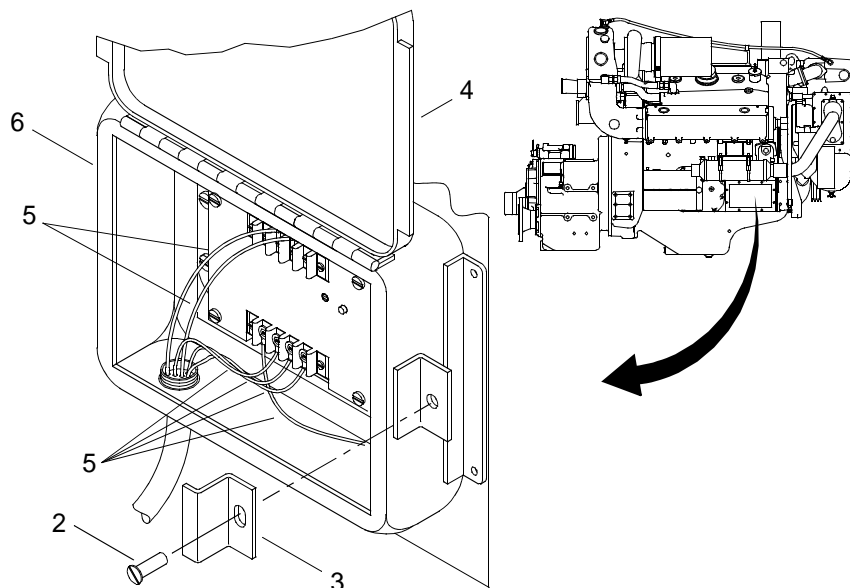

3. Tag and disconnect wiring harness (5) from speed switch (6).
4. Remove the stuffing tube retaining cap (7) and the stuffing tube packing (8) from stuffing tube (9).

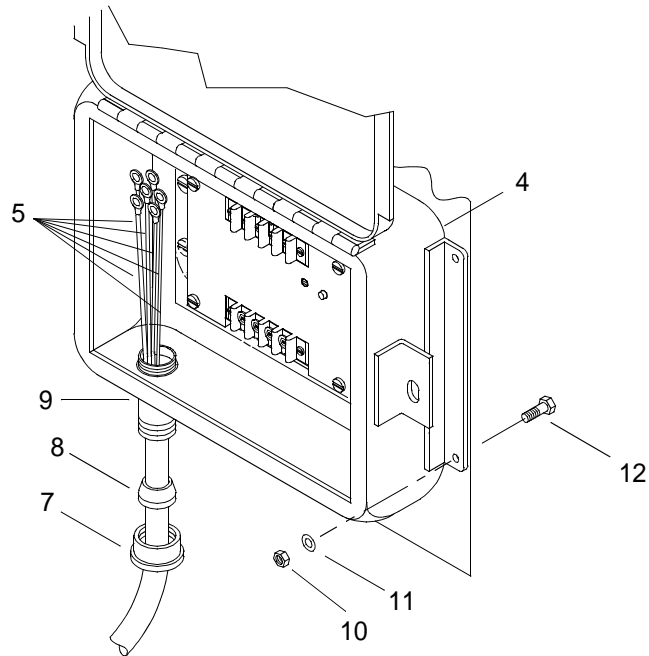

5. Remove the wiring harness (5) from the overspeed governor box (4).
6. Remove four hex nuts (10) and lock washers (11) from cap screws (12) securing the overspeed governor box (4) to the engine.
7. Remove four cap screws (13), lock washers (14) and hex nuts (15) from mounting plate (16).

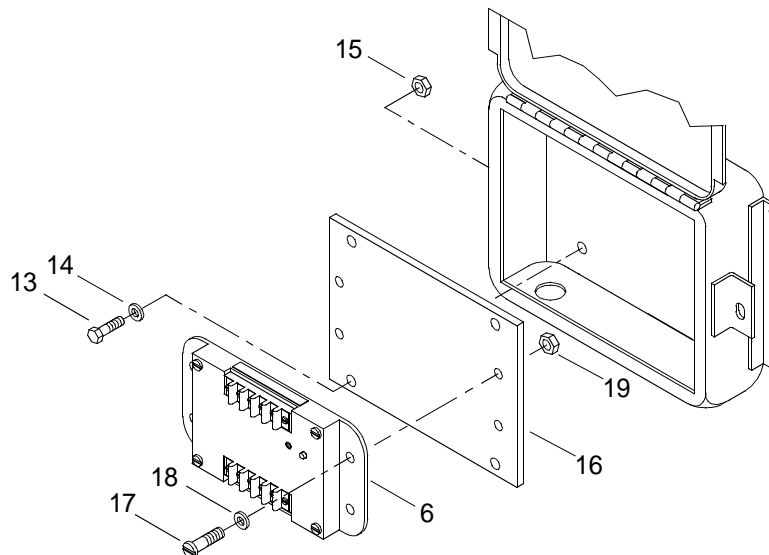

8. Remove four screws (17), lock washers (18) and hex nuts (19) from speed switch (6) and remove speed switch (6).

PERFORM BENCH ADJUSTMENT

1. Determine the desired set point frequency.

NOTE

The maximum engine RPM is 2100. To determine the max engine set point, add approximately 10%, or 200 RPM, this will shut the engine down at 2300 RPM.

The mini generators RPM is twice the engine RPM.

- a. Determine the mini generators RPM at the engine RPM set point.
- b. Divide the mini generators RPM by two, this will give the set point frequency in Hz.

WARNING



ELECTRICAL

2. Connect a power supply to terminals 1 and 2.

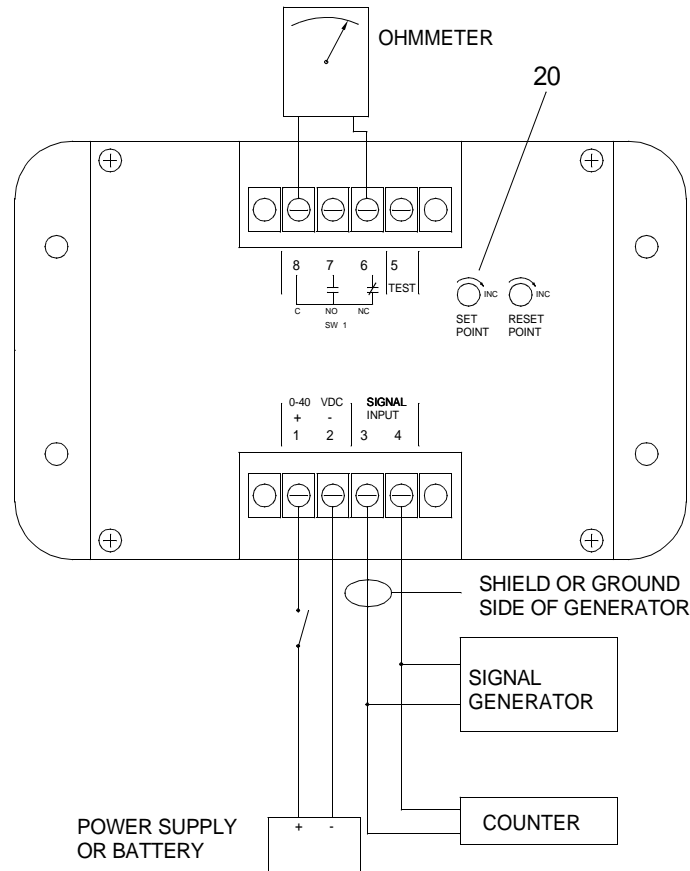

3. Connect a signal generator and frequency counter to terminals 3 and 4.
4. Connect an ohmmeter to terminals 6 and 8.

5. Turn set point pot (20) twenty turns clockwise or until a clicking sound is heard.

WARNING



ELECTRICAL

6. Turn the power supply, frequency counter and the signal generator on.
7. Adjust the input frequency on the signal generator to the set point determined in step 1.
8. Set signal generator output level to 1 VAC or greater.
9. Verify the ohmmeter reads zero ohms.
10. Turn the set point pot counter clockwise slowly until the ohmmeter reads an open circuit.
11. Recheck the set point adjustment.
 - a. Lower the frequency setting on the signal generator.
 - b. Turn off and then back off and then back on the power.
 - c. Slowly increase the frequency on the signal generator until the switch trips and the ohmmeter shows zero ohms.
 - d. Repeat steps 5 through 11 if it fails.

INSTALL OVERSPEED GOVERNOR

1. Install four screws (17), lock washers (18) and hex nuts (19) securing speed switch (6) on mounting plate (16).

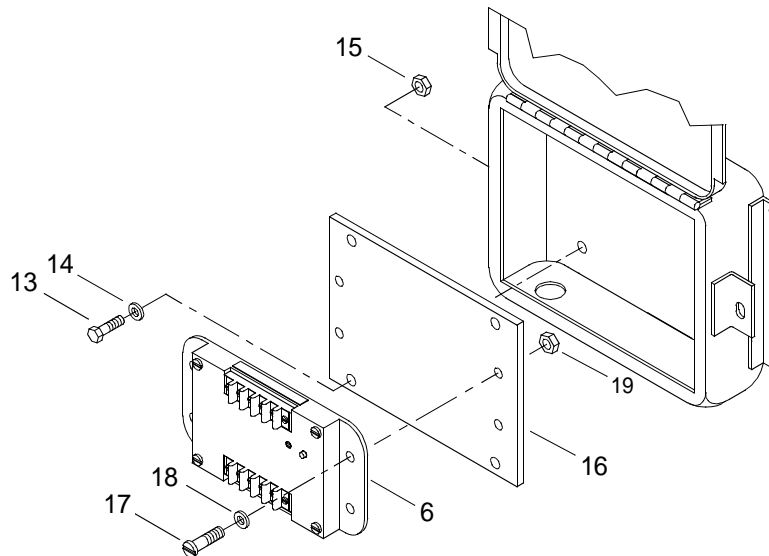

2. Install four cap screws (13), lock washers (14) and hex nuts (15) securing mounting plate (16) in overspeed governor box (4).

3. Install hex nuts (10) and lock washers (11) on hex head bolts (12) securing the overspeed governor box (4) to the engine.

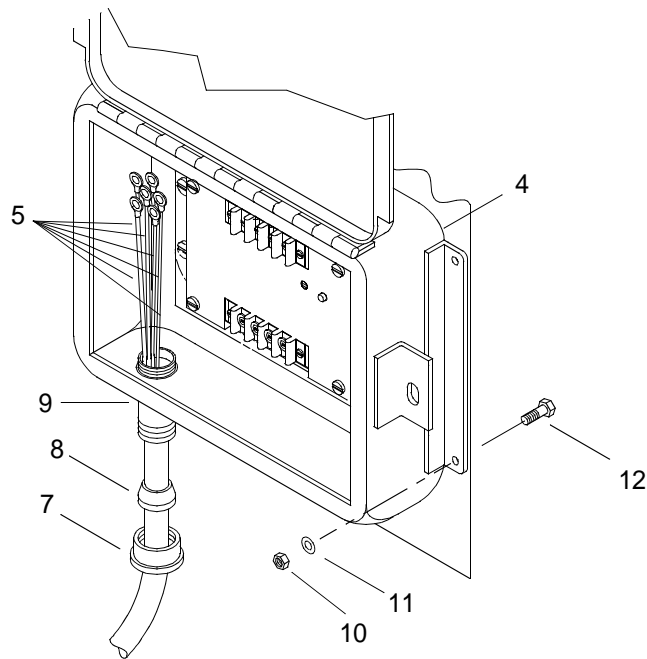

4. Install the wiring harness (5) in the overspeed governor box (4).
5. Install the stuffing tube retaining cap (7) and the stuffing tube packing (8) in stuffing tube (9).
6. Install wiring harness (5) on speed switch (6).
7. Position MAIN circuit breaker on propulsion module circuit breaker panel A6 to on. (TM 55-1945-205-10-1)
8. Adjust the overspeed governor switch.

PERFORM SETPOINT VERIFICATION FOR OVERSPEED PROTECTION

1. Determine the desired set point frequency.

NOTE

The maximum engine RPM is 2100. To determine the max engine set point, add approximately 10%, or 200 RPM, this will shut the engine down at 2300 RPM.

The mini generators RPM is twice the engine RPM.

- a. Determine the mini generators RPM at the engine RPM set point.
- b. Divide the mini generators RPM by two, this will give the set point frequency in Hz.

2. Connect a temporary jumper wire (21) between terminals 2 and 5.

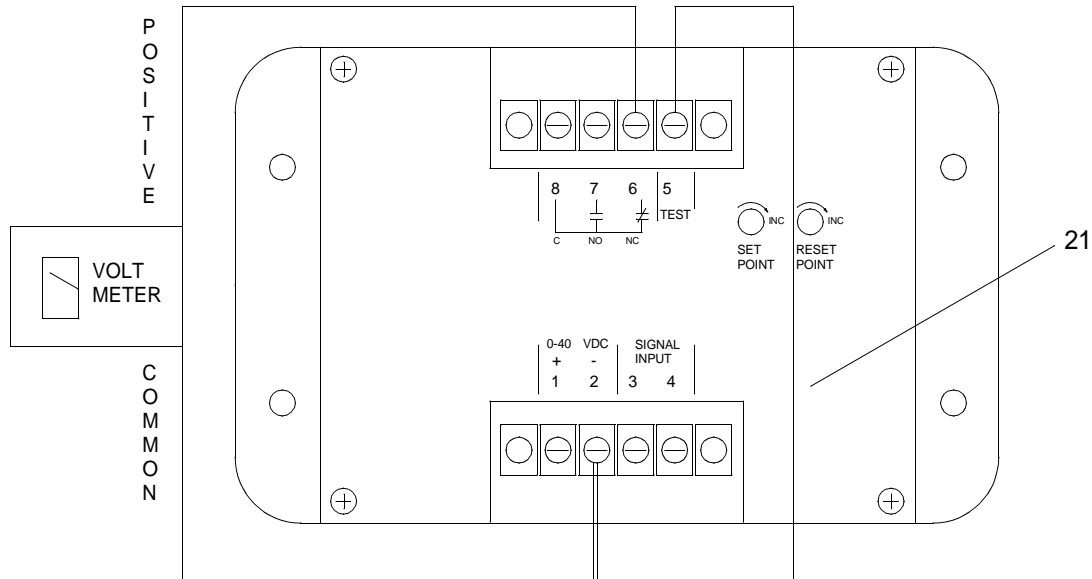

3. Convert the frequency set point to RPM by multiplying by 0.67 which will give you the test set point.

WARNING



ELECTRICAL

4. Apply power to the speed switch.
5. Connect the DC voltmeter between terminals 2 and 6.
 - a. Connect the common lead of the voltmeter to terminal 2.
 - b. Connect the positive lead of the voltmeter to terminal 6.
6. Start the engine. (TM 55-1945-205-10-1)
7. Monitor the tach and slowly increase the engine RPM to the test set point reading.
8. Observe the DC voltmeter, it should indicate battery voltage before the set point is activated and the relay trips.
9. When the relay trips verify the test set point on the voltmeter reads zero volts.
10. Remove jumper (21) from terminals 2 and 5 and reset speed switch.
11. Install two screws (2) and retainer clips (3) securing the overspeed governor box cover (4).
12. Shut engine down. (TM 55-1945-205-10-1)

END OF WORK PACKAGE

**UNIT LEVEL MAINTENANCE
CAUSEWAY FERRY
AUTO SHUTDOWN SYSTEM EMERGENCY STOP SOLENOID
REPLACEMENT**

INITIAL SETUP:

Tools

Tool Kit, General Mechanic's (Rail and Marine) (Item 131, WP 0188 00)

Materials/Parts

Solenoid, Emergency Shutdown
(88136)
NSN 5945-01-337-0816
PN 23504197

Personnel Required

Engineer 88L

References

TM 55-1945-205-10-1

Equipment Condition

Engine Cool To Touch.
SINGARS Antenna Removed. (TM 11-5820-890-10-8)
Main Navigation Mast Removed. (TM 55-1945-205-24-1-1)
Intake Plenum Assembly Removed. (TM 55-1945-205-24-1-1)
Operators Cab Removed. (TM 55-1945-205-24-1-1)

REMOVE AUTO SHUTDOWN SYSTEM EMERGENCY STOP SOLENOID

1. Verify MAIN circuit breaker (1) on propulsion module circuit breaker panel A6 is off.

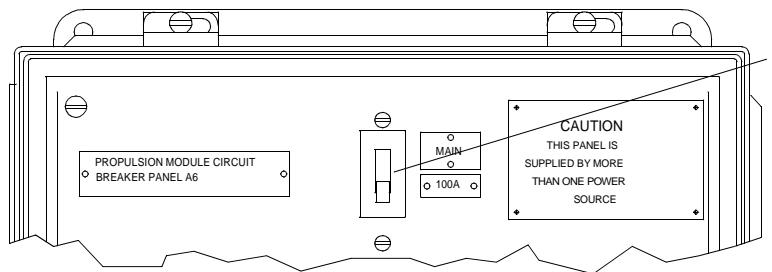

2. Tag electrical wires.
3. Remove two hex nuts (2), electrical wiring harness (3) and diodes (4) from air shutdown actuator (5).

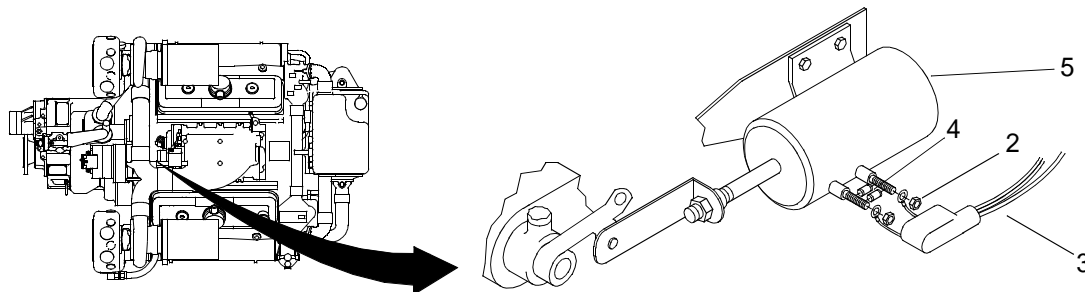

4. Remove clip (6), washer (7) and pin (8) securing connecting link (9) to air shutdown pivot arm (10).

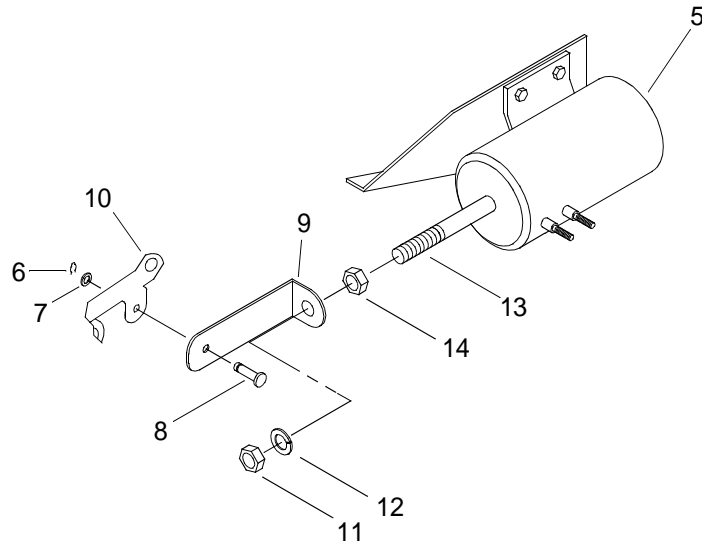

5. Remove hex nut (11) and washer (12) from solenoid shaft (13).
6. Remove connecting link (9) from shaft (13) of emergency stop solenoid (5).
7. Using a ruler, measure and record the length of the exposed threads in front of hex nut (14) to facilitate reinstallation of the connecting link (9).
8. Remove hex nut (14) from shaft (13) of emergency stop solenoid (5).
9. Remove two cap screws (15 and 16), lock washers (17 and 18) and spacers (19 and 20) that secure the solenoid mounting bracket (21) and solenoid (5) to engine.

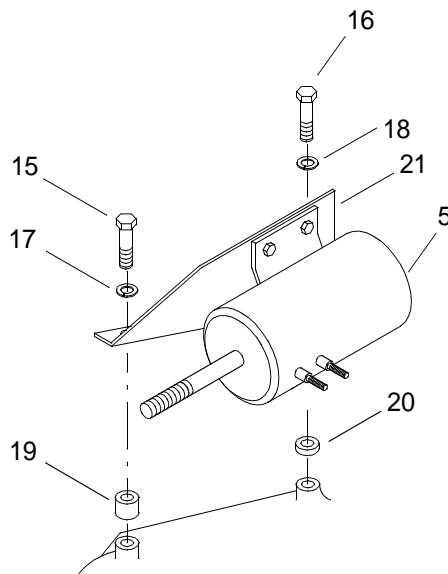

- Remove three cap screws (22), lock washers (23) and ground wire (24) that secures solenoid (5) to solenoid bracket (21).

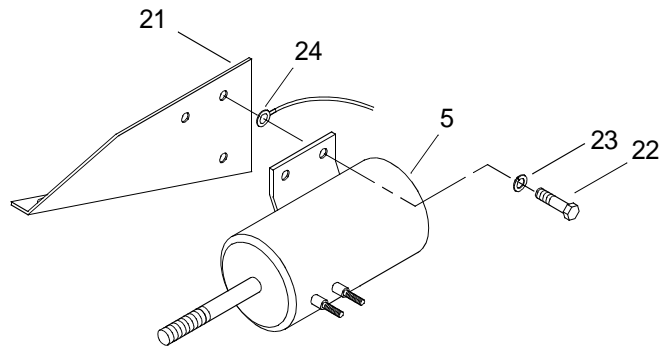

- Remove solenoid (5) from solenoid bracket (21).

INSTALL EMERGENCY STOP SOLENOID

- Install three cap screws (22), lock washers (23) and ground wire (24) to secure solenoid to solenoid mounting bracket (21).
- Tighten bolts (22).
- Install two spacers (19 and 20), lock washers (17 and 18) and cap screws (15 and 16) to secure the solenoid mounting bracket (21) and solenoid (5) to engine.

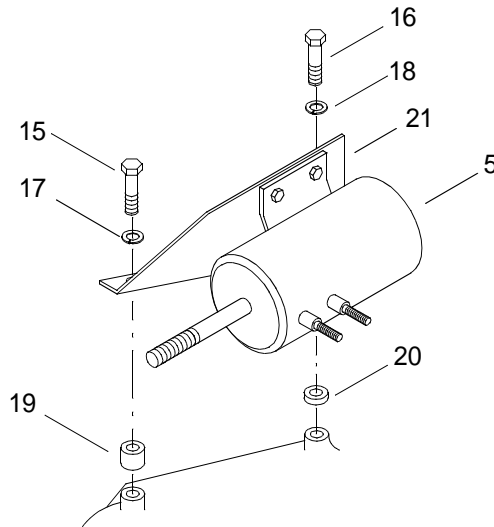

- Tighten bolts (15 and 16).

-
5. Install hex nut (14) on the shaft (13) of emergency stop solenoid (5) to length previously recorded.

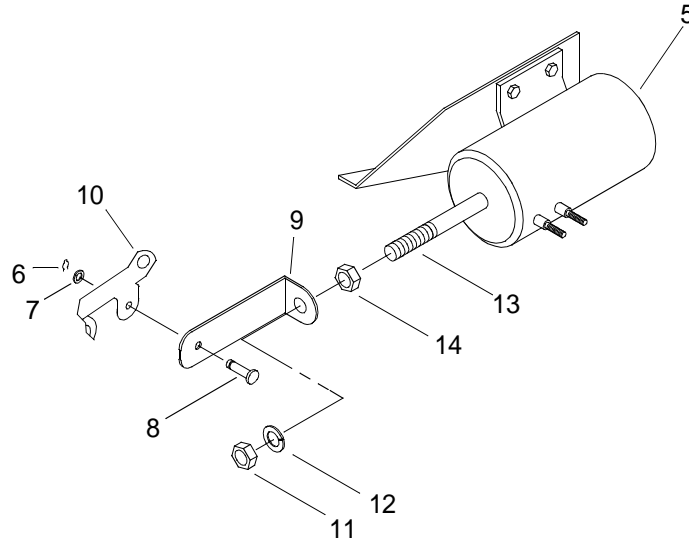

6. Install connecting link (9) on shaft (13) of emergency stop solenoid (5).
7. Install washer (12) and hex nut (11) on solenoid link (9) and tighten hex nut (11).
8. Install pin (8) to reconnect air shutdown pivot arm (10) to solenoid link (9).
9. Install washer (7) and spring clip (6) onto pin (8).
10. Install diodes (4), electrical wires harness (3) and two hex nuts (2) on the emergency stop solenoid (5).

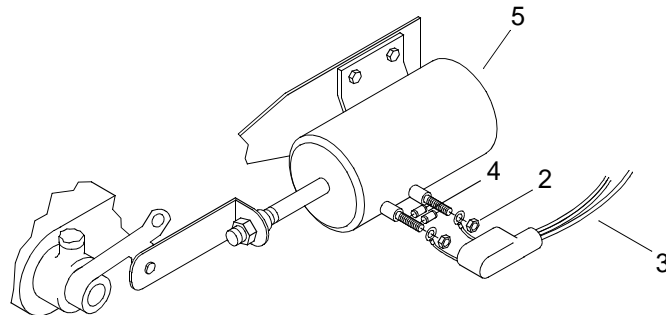

11. Tighten hex nuts (2).
12. Remove tags from wiring.
13. Install operators cab. (TM 55-1945-205-24-1-1)
14. Install intake plenum assembly. (TM 55-1945-205-24-1-1)
15. Install main navigation mast. (TMM 55-1945-205-24-1-1)
16. Install SINGARS antenna. (TM 11-5820-890-10-8)
17. Perform operational checks. (TM 55-1945-205-10-1)

END OF WORK PACKAGE

**UNIT LEVEL MAINTENANCE
CAUSEWAY FERRY
AUTO SHUTDOWN SYSTEM HIGH WATER TEMPERATURE SWITCH
REPLACEMENT**

INITIAL SETUP:**Tools**

Tool Kit, General Mechanic's (Rail and Marine) (Item 131, WP 0188 00)
Pan, Drain (Item 87, WP 0188 00)

Materials/Parts

Switch, Water Temperature Pressure
(72528)
PN 5146080
Tape, Antiseize (Item 34, WP 0187 00)
Spill Clean-Up Kit, Hazardous Material (Item 30, WP 0188 00)

Personnel Required

Engineer 88L

References

TM 55-1945-205-10-1

REMOVE AUTO SHUTDOWN SYSTEM HIGH WATER TEMPERATURE SWITCH

1. Verify MAIN circuit breaker (1) on the propulsion module circuit breaker panel A6 is off.

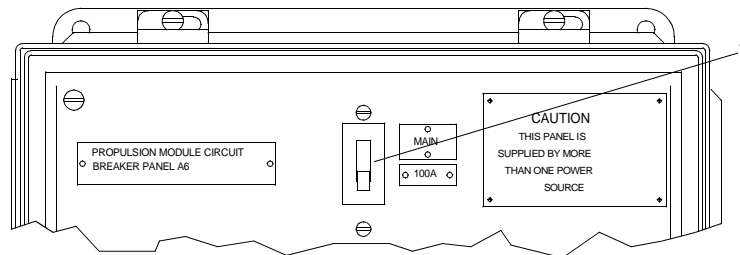

2. Tag all wires prior to disconnection to allow for ease of identification when installing the new switch.

3. Tag and disconnect wires (2) from switch (3).

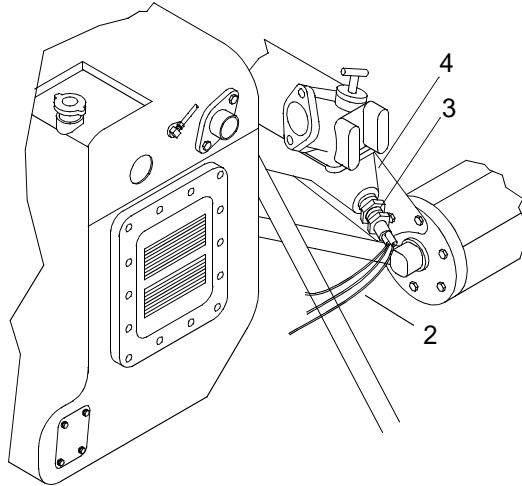

4. Place drain pan under switch (3).

WARNING



CHEMICAL



VAPOR



EYE PROTECTION



POISON

5. Remove switch (3) from thermostat housing (4).

INSTALL HIGH WATER TEMPERATURE SWITCH

1. Wrap threads of new switch (3) with antiseize tape.
2. Install new switch (3) in thermostat housing (4).

WARNING

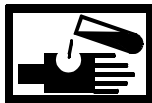

CHEMICAL



VAPOR



EYE PROTECTION



POISON



SLICK FLOOR

3. Remove spill pan and dispose of contents in accordance with local procedures.
4. Clean any spilled fluid with a spill kit and dispose of contaminated material in accordance with local procedure.
5. Connect wires (2) to switch (3).
6. Remove tags from wires (2)
7. Service fresh water cooling system. (WP 0133 00)
8. Perform operational checks. (TM 55-1945-205-10-1)

END OF WORK PACKAGE

**UNIT LEVEL MAINTENANCE
CAUSEWAY FERRY
AUTO SHUTDOWN SYSTEM LOW OIL PRESSURE SWITCH
REPLACEMENT**

INITIAL SETUP:**Tools**

Tool Kit, General Mechanic's (Rail and Marine) (Item 131, WP 0188 00)
Pan, Drain (Item 87, WP 0188 00)

Materials/Parts

Switch, Oil Pressure
(72582)
PN 23511817
Tape, Antiseize (Item 34, WP 0187 00)
Spill Clean-Up Kit, Hazardous Material (Item 30, WP 0187 00)

Personnel Required

Engineer 88L

References

TM 55-1945-205-10-1

REMOVE AUTO SHUTDOWN SYSTEM OIL PRESSURE SWITCH**NOTE**

Tag all wires prior to disconnection for identification when installing the new switch.

1. Verify MAIN circuit breaker (1) on propulsion module circuit breaker panel A6 is off.

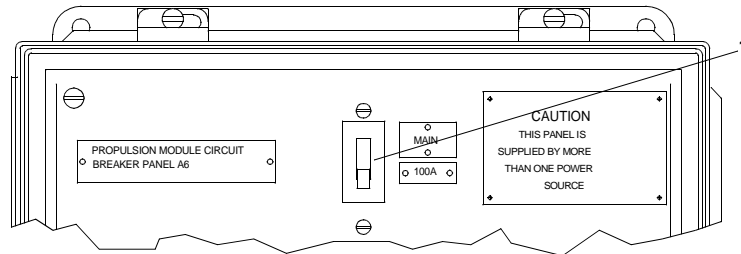

2. Tag and disconnect wires (2) from oil pressure switch (3).

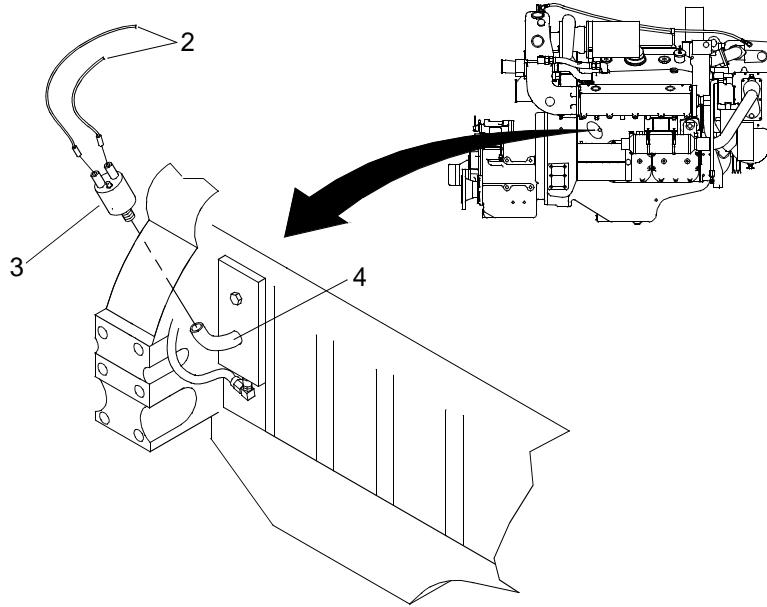

3. Position drain pan below oil pressure switch (3).
4. Remove oil pressure switch (3) from engine block elbow (4).

INSTALL OIL PRESSURE SWITCH

1. Wrap threads of new oil pressure switch (3) with antiseize tape.
2. Install new switch (3) in engine block elbow (4).
3. Remove drain pan and dispose of contents in accordance with local procedures.
4. Clean up spilled fluid with a spill kit and dispose of spill kit waste in accordance with local procedures.
5. Connect wires (2) to oil pressure switch (3).
6. Remove tags from wires (2).
7. Perform operational checks. (TM 55-1945-205-10-1)

END OF WORK PACKAGE

**UNIT LEVEL MAINTENANCE
CAUSEWAY FERRY
AUTO SHUTDOWN SYSTEM FUEL OIL PRESSURE SWITCH
REPLACEMENT**

INITIAL SETUP:**Tools**

Tool Kit, General Mechanic's, (Rail and Marine) (Item 131, WP 0188 00)
 Gloves (Item 52, WP 0188 00)
 Goggles (Item 54, WP 0188 00)
 Pan, Drain (Item 87, WP 0188 00)

Materials/Parts

Switch, Fuel Oil Pressure
 (72582)
 PN ISD40021
 Kit, Spill (Item 32, WP 0187 00)
 Tape, Antiseize (Item 34, WP 0187 00)

Personnel Required

Engineer 88L

References

TM 55-1945-205-10-1

REMOVE FUEL AUTO SHUTDOWN SYSTEM OIL PRESSURE SWITCH**NOTE**

This task is typical for both port and starboard fuel oil pressure switches on both port and starboard engines.

1. Verify MAIN circuit breaker (1) on propulsion module circuit breaker panel A6 is off.

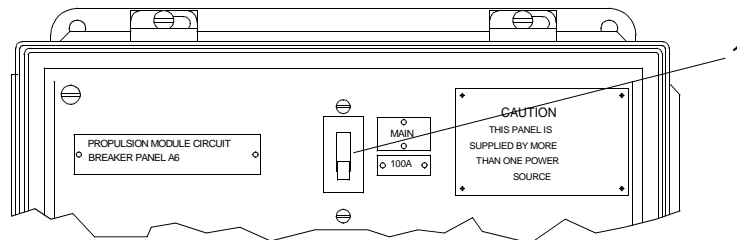

2. Verify fuel supply and return valves (2) are closed.

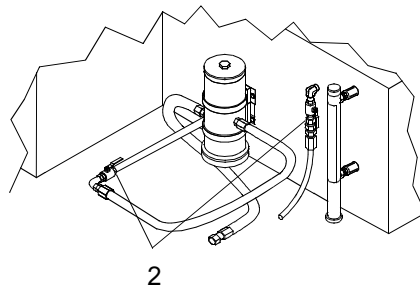

- Place drain pan under fuel oil pressure switch (3).

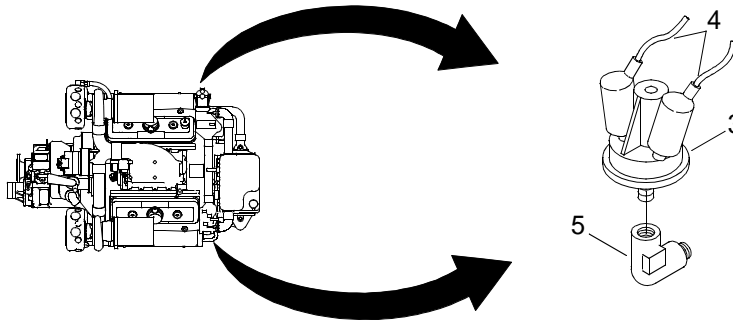

- Tag and disconnect wiring harness (4) from fuel oil pressure switch (3).

WARNING



CHEMICAL

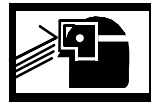

EYE PROTECTION

- Remove fuel oil pressure switch (3) from elbow (5) and discard.

WARNING



CHEMICAL

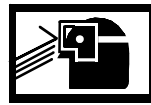

EYE PROTECTION

- Remove drain pan and dispose of contents in accordance with local procedures.

INSTALL FUEL OIL PRESSURE SWITCH

- Wrap fuel oil pressure switch (3) threads with antiseize tape.
- Install new fuel oil pressure switch (3) in elbow (5).
- Connect wires (4) to fuel oil pressure switch (3).
- Prime the fuel system (WP 0077 00)
- Start engine. (TM 55-1945-205-10-1)
- Check the fuel oil pressure switch (3) for leaks.
- Shut engine down. (TM 55-1945-205-10-1)

WARNING

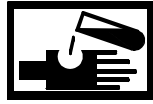
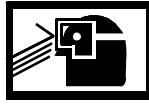
**CHEMICAL****EYE PROTECTION****SLICK FLOOR**

8. Clean up spilled fluids with spill kit and dispose of spill kit waste in accordance with local procedure.
9. Perform operational checks. (TM 55-1945-205-10-1)

END OF WORK PACKAGE

**UNIT LEVEL MAINTENANCE
CAUSEWAY FERRY
PIPE NIPPLES, ELBOWS, TEES, ADAPTORS AND PLUGS
REPLACEMENT**

INITIAL SETUP:**Tools**

Tool Kit, General Mechanic's (Rail and Marine) (Item 131, WP 0188 00)
Gloves, Chemical (Item 52, WP 0188 00)
Goggles, Industrial (Item 54, WP 0188 00)
Pan, Drain (Item 87, WP 0188 00)

Materials/Parts

Tape, Antiseizing (Item 34, WP 0187 00)
Sealing Compound, (Pipe Sealant) (Item 29, WP 0187 00)
Spill Clean-Up Kit, Hazardous Material (Item 32, WP 0187 00)

Personnel Required

Engineer 88L

References

TM 55-1945-205-10-1

REMOVE PIPE NIPPLES, ELBOWS, TEES, ADAPTORS AND PLUGS**NOTE**

The following steps are typical for removal of pipe nipples.

1. Remove nipple (1).

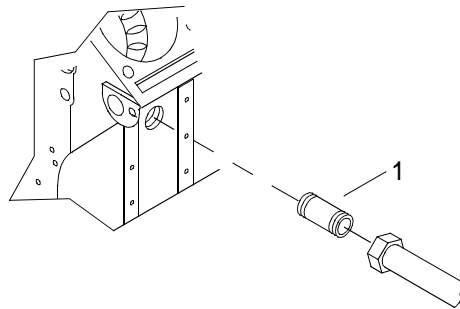

- a. Place drain pan under the nipple (1).

WARNING

**CHEMICAL****EYE PROTECTION**

- b. Disconnect associated hardware attached to nipple (1).
 - c. Remove nipple (1) and discard.

WARNING

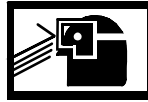
**CHEMICAL****EYE PROTECTION**

- d. Remove drain pan and dispose of contents in accordance with local procedures.

NOTE

The following steps are typical for the removal of elbows.

2. Remove elbow (2).

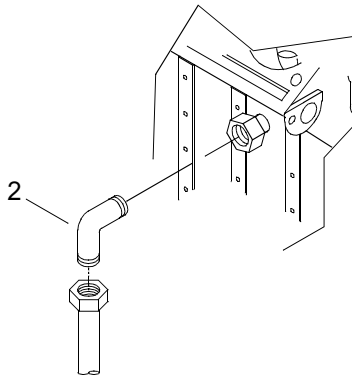

- a. Place drain pan under elbow (2).

WARNING

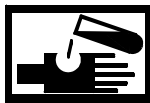
**CHEMICAL****EYE PROTECTION**

- b. Disconnect associated hardware attached to elbow (2).
- c. Remove elbow (2) and discard.

WARNING

**CHEMICAL****EYE PROTECTION**

- d. Remove drain pan and dispose of contents in accordance with local procedures.

NOTE

The following steps are typical for removal of tees.

3. Remove tee (3).

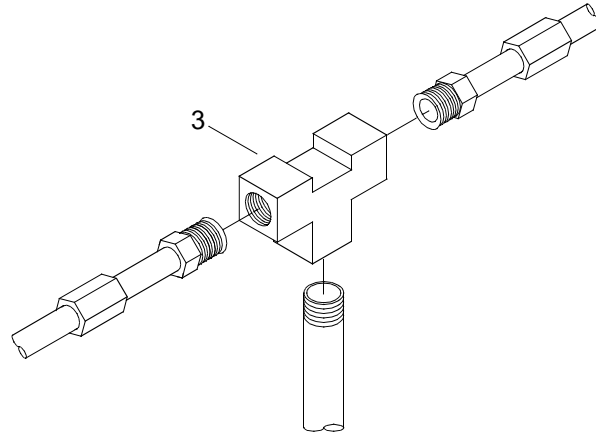

- a. Place drain pan under tee (3).

WARNING

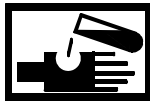
**CHEMICAL****EYE PROTECTION**

- b. Disconnect associated hardware attached to tee (3).
- c. Remove tee (3) and discard.

WARNING

**CHEMICAL****EYE PROTECTION**

- d. Remove drain pan and dispose of contents in accordance with local procedures.

NOTE

The following steps are typical for removal of adaptors.

4. Remove adaptor (4).

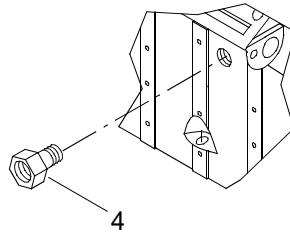

- a. Place drain pan under adaptor (4).

WARNING

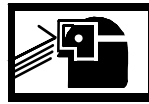
**CHEMICAL****EYE PROTECTION**

- b. Disconnect associated hardware attached to adaptor (4).
c. Remove adaptor (4) and discard.

WARNING

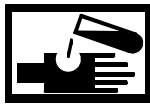
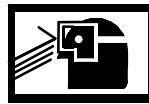
**CHEMICAL****EYE PROTECTION**

- d. Remove drain pan and dispose of contents in accordance with local procedures.

NOTE

The following steps are typical for removal of plugs

5. Remove plug (5).

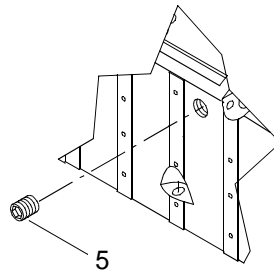

- a. Place drain pan under plug (5).

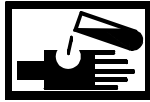
WARNING

CHEMICAL

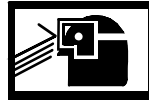

EYE PROTECTION

- b. Remove plug (5) and discard.

WARNING

CHEMICAL



EYE PROTECTION

- c. Remove drain pan and dispose of contents in accordance with local procedures.

INSTALL PIPE NIPPLES, ELBOWS, TEES, ADAPTORS AND PLUGS**NOTE**

The following steps are typical for installation of plugs.

1. Install plug (5).

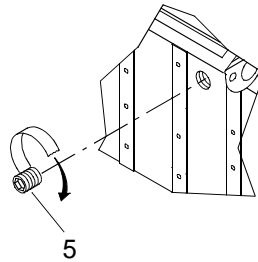

- a. Apply sealing compound on new plug (5) threads.
b. Install new plug (5).

WARNING

CHEMICAL



EYE PROTECTION



SLICK FLOOR

- c. Clean up spilled fluid with a spill kit and dispose of spill kit waste in accordance with local procedures.
d. Perform operational checks. (TM 55-1945-205-10-1)

NOTE

The following steps are typical for the installation of adaptors.

2. Install adaptor (4).

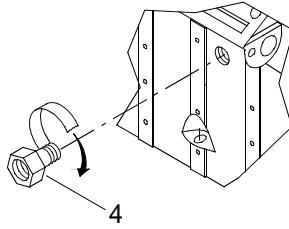

- a. Apply sealing compound to new adaptor (4) threads and associated hardware.
- b. Install new adaptor (4) between associated hardware.
- c. Connect associated hardware to adaptor (4).

WARNING

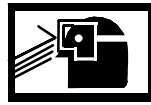
**CHEMICAL****EYE PROTECTION****SLICK FLOOR**

- d. Clean up spilled fluid with a spill kit and dispose of spill kit waste in accordance with local procedures.
- e. Perform operational checks. (TM 55-1945-205-10-1)

NOTE

The following steps are typical for installation of tees.

3. Install tee (3).

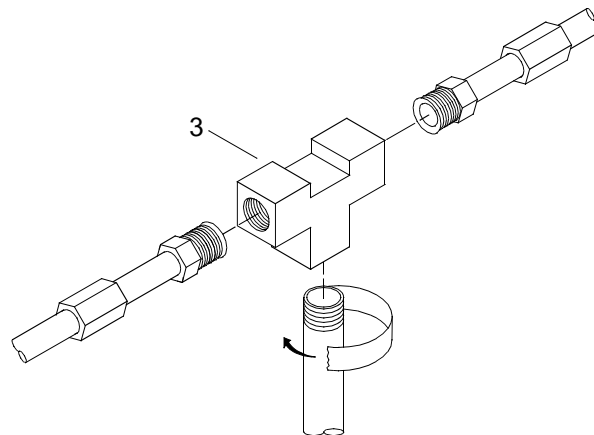

- a. Wrap associated hardware threads with antiseize tape.
- b. Position new tee (3) between associated hardware.

- c. Connect associated hardware to tee (3).

WARNING



CHEMICAL



EYE PROTECTION



SLICK FLOOR

- d. Clean up spilled fluid with a spill kit and dispose of spill kit waste in accordance with local procedures.
- e. Perform operational checks. (TM 55-1945-205-10-1)

NOTE

The following steps are typical for installation of elbows.

4. Install elbow (2).

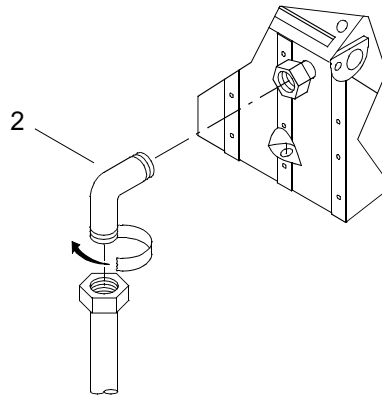

- a. Wrap both ends of new elbow (2) threads with antiseize tape.
- b. Position new elbow (2) between associated hardware.
- c. Connect associated hardware to elbow (2).

WARNING



CHEMICAL



EYE PROTECTION



SLICK FLOOR

- d. Clean up spilled fluid with a spill kit and dispose of spill kit waste in accordance with local procedures.
- e. Perform operational checks. (TM 55-1945-205-10-1)

NOTE

The following steps are typical for the installation of pipe nipples.

5. Install nipple (1).

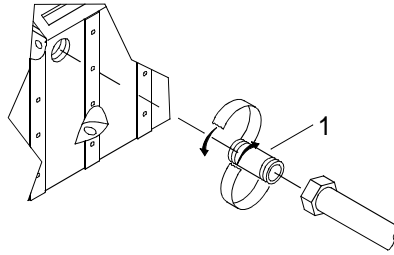

- Wrap both ends of new nipple (1) threads with antiseize tape.
- Position new nipple (1) between associated hardware.
- Connect associated hardware to nipple (1).

WARNING

**CHEMICAL****EYE PROTECTION****SLICK FLOOR**

- Clean up spilled fluid with a spill kit and dispose of spill kit waste in accordance with local procedures.
- Perform operational checks. (TM 55-1945-205-10-1)

END OF WORK PACKAGE

**DIRECT SUPPORT MAINTENANCE
CAUSEWAY FERRY
ELECTRICAL WIRING
REPAIR**

INITIAL SETUP:

Personnel Required

Engineer 88L

References

46 CFR 129.340

REPAIR ELECTRICAL WIRING

For electrical wiring repair procedures, refer to 46 CFR 129.340.

END OF WORK PACKAGE

**UNIT, DIRECT SUPPORT AND GENERAL SUPPORT MAINTENANCE
CAUSEWAY FERRY
DIESEL ENGINE
TORQUE LIMITS**

INTRODUCTION

When To Use Torque Limits

When a torque is not specified in an individual work package, use the procedures in this work package to determine proper torque limits and use of adaptors with torque wrenches.

How To Use Adaptors With Torque Wrenches

When an adaptor is necessary due to space or type of fitting being torqued, it must be determined how the adaptor changes the amount of force applied. If the adaptor increases or decreases the distance from the drive of the torque wrench to the fitting being torqued, an equation must be used to compensate for the difference.

NOTE

The following abbreviations apply to the below procedures:

DT = Desired Torque
LT = Length of Torque Wrench
AL = Adaptor Length
AT = Applied Torque

1. If the adaptor used decreases the distance between the center of the torque wrench handle and the center of the drive, first find the desired torque for the fitting, then calculate as follows:

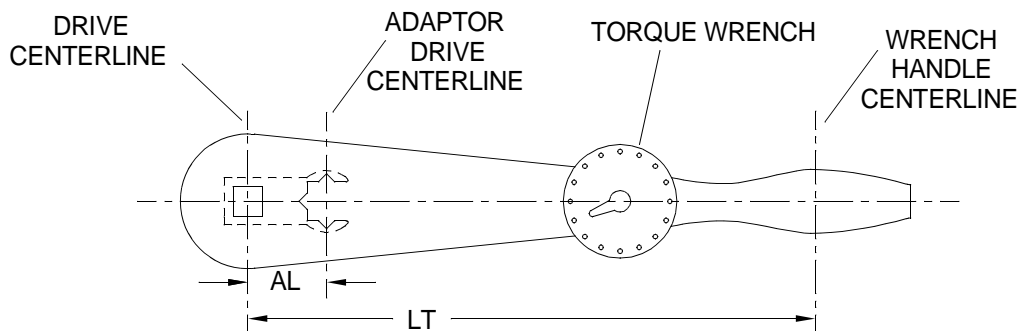

- a. Multiply DT by LT.
 - b. Subtract AL from LT.
 - c. Divide the first answer by the second answer to find AT.
2. If the adaptor used increases the distance between the center of the torque wrench handle and the center of the drive, first find the desired torque for the fitting, then calculate as follows:

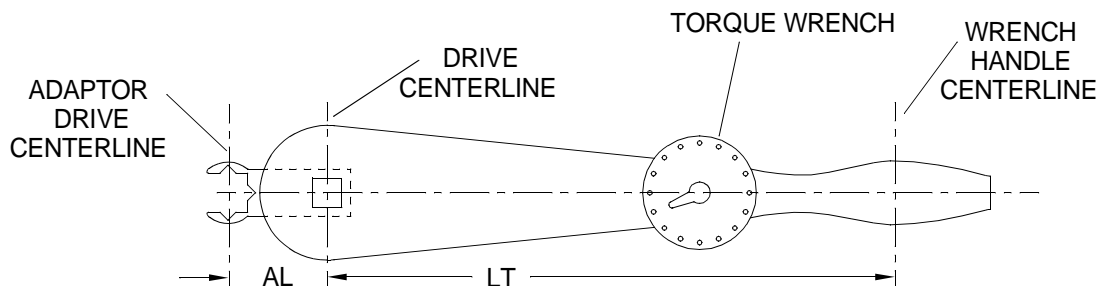

- a. Multiply DT by LT.
- b. Add AL and LT.
- c. Divide the first answer by the second answer to find AT.

TORQUE TABLES

How To Use Torque Tables

1. Measure the diameter of the bolt to be torqued.

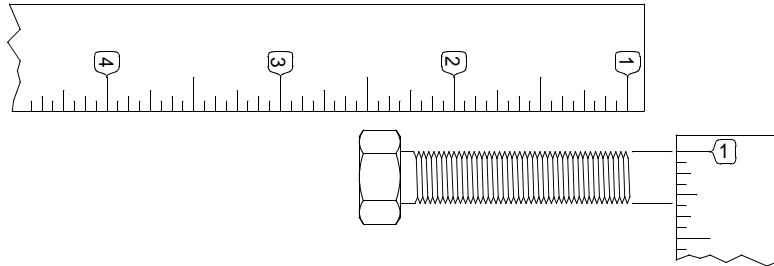

2. For SAE fasteners, determine the threads per inch by counting the threads. For metric fasteners, determine the thread pitch using a thread pitch gage.
3. Determine the type of markings on the bolt you are torquing by comparing the markings on the head of the bolt with the chart below.

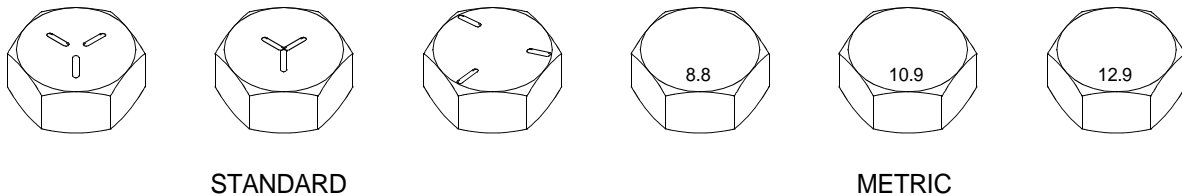

4. Determine if this will be a wet or dry torque.
 - a. Wet torque is any bolt that is lubricated or coated with an antiseize compound.
 - b. Dry torque is any bolt that is not lubricated or coated with an antiseize compound.
5. On the table below, locate the bolt to be torqued.
 - a. Locate the diameter of the bolt.
 - b. Determine the threads per inch for the SAE fastener or the thread pitch for the metric fastener.
 - c. Slide across the table to the proper grade.
 - d. Choose wet or dry.
 - e. Slide down the proper column and across the proper row until they intersect, this is the proper torque value.

Table 1. SAE Standard Torque Table.

DIA IN.	THREADS PER INCH	SAE GRADE NO. 2				SAE GRADE NO. 5				SAE GRADE NO. 8			
		DRY		WET		DRY		WET		DRY		WET	
		IN. LBS	N-m	IN. LBS	N-m	IN. LBS	N-m	IN. LBS	N-m	IN. LBS	N-m	IN. LBS	N-m
1/4	20	66	7.46	49	5.54	101	11.41	76	8.58	143	16.15	107	12.09
1/4	28	75	8.47	56	6.33	116	13.10	87	9.83	164	18.53	123	13.89
5/16	18	135	15.25	101	11.41	209	23.61	157	17.73	295	33.32	221	24.96
5/16	24	150	17.17	112	12.65	230	25.98	173	19.54	327	36.94	245	27.68
3/8	16	240	27.11	180	20.33	370	41.80	278	31.40	523	59.08	392	44.28
3/8	24	272	30.73	204	23.04	420	47.44	315	35.58	593	66.99	445	50.27
7/16	14	384	43.38	288	32.53	593	66.99	445	50.27	837	94.55	628	70.94
7/16	20	428	48.35	321	36.26	662	74.78	496	56.03	935	105.62	700	79.07
1/2	13	585	66.08	439	49.59	904	102.12	678	76.59	1277	144.25	958	108.22
1/2	20	660	74.55	495	55.92	1020	115.22	764	86.30	1440	162.66	1080	122.00

Table 2. SAE Standard Torque Table.

		SAE GRADE NO. 2				SAE GRADE NO. 5				SAE GRADE NO. 8			
													
		DRY		WET		DRY		WET		DRY		WET	
DIA IN.	THREADS PER INCH	FT LBS	N-m	FT LBS	N-m	FT LBS	N-m	FT LBS	N-m	FT LBS	N-m	FT LBS	N-m
9/16	12	70	94.92	53	71.87	109	147.80	82	111.19	154	208.82	115	155.94
9/16	18	78	105.77	59	80.00	121	164.08	91	123.40	171	231.88	128	173.57
5/8	11	97	131.53	73	98.99	150	203.40	113	153.23	212	287.47	159	215.60
5/8	18	110	149.16	82	111.19	170	230.52	127	172.21	240	325.44	180	244.08
3/4	10	172	233.23	129	174.92	269	364.76	201	272.56	376	509.86	282	382.39
3/4	16	192	260.35	144	195.26	297	402.73	223	302.29	420	569.52	315	427.14
1	8	-	-	-	-	644	873.26	483	654.95	909	1232.60	683	926.15
1	12	-	-	-	-	704	954.62	528	715.97	995	1349.22	746	1011.58

Table 3. Metric Standard Torque Table.

		CLASS 4.6				CLASS 4.8				CLASS 5.8			
													
		DRY		WET		DRY		WET		DRY		WET	
DIA MM	THREAD PITCH	N-m	IN. LBS	N-m	IN. LBS	N-m	IN. LBS	N-m	IN. LBS	N-m	IN. LBS	N-m	IN. LBS
3.0	0.5	.50	4	.40	4	.70	6	.50	4	-	-	-	-
3.5	0.6	.80	7	.60	5	1.10	10	.80	7	-	-	-	-
4.0	0.7	1.20	11	.90	8	1.60	14	1.20	11	-	-	-	-
5.0	0.8	2.40	21	1.80	16	3.30	29	2.50	22	4.00	35	3.00	27
6.0	1.0	4.00	35	3.00	27	5.66	50	4.20	37	6.90	61	5.20	26
8.0	1.25	9.90	88	7.40	66	13.60	120	10.20	90	16.70	148	12.50	111
10.0	1.50	19.60	174	14.70	130	27.00	239	20.00	177	33.10	293	24.80	220
12.0	1.75	34.10	302	25.60	227	47.00	416	35.00	310	58.00	51	43.00	381
14.0	2.0	54.30	481	40.80	361	75.00	664	56.00	496	92.00	814	69.00	611

Table 4. Metric Standard Torque Table.

DIA MM	THREAD PITCH	CLASS 8.8				CLASS 9.8				CLASS 10.9			
		DRY		WET		DRY		WET		DRY		WET	
		N-m	FT LBS	N-m	FT LBS	N-m	FT LBS	N-m	FT LBS	N-m	FT LBS	N-m	FT LBS
8.0	1.25	26.40	19	19.80	15	28.50	21	21.40	16	36.50	27	27.30	20
10.0	1.50	52.20	38	39.20	29	56.60	42	42.40	31	72.20	53	54.20	40
12.0	1.75	91.00	67	68.00	50	99.00	73	74.00	55	126.00	93	94.00	69
14.0	2.00	145.00	107	109.00	80	157.00	116	118.00	87	200.00	147	150.00	111
16.0	2.00	226.00	167	170.00	125	245.00	181	184.00	136	313.00	231	235.00	173
20.0	2.50	441.00	325	331.00	244	478.00	353	358.00	264	610.00	450	458.00	338
24.0	3.00	762.00	562	572.00	422	826.00	609	620.00	457	1055.00	778	791.00	583
30.0	3.50	1515.00	1117	1136.00	838	1641.00	1210	1231.00	908	2095.00	1545	1572.00	1159
36.0	4.00	2647.00	1952	1985.00	1464	2868.00	2115	2151.00	1586	3662.00	2701	2746.00	2025

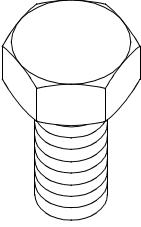
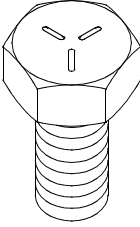
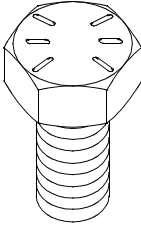
END OF WORK PACKAGE

**UNIT, DIRECT SUPPORT AND GENERAL SUPPORT MAINTENANCE
CAUSEWAY FERRY
WIRING DIAGRAMS**

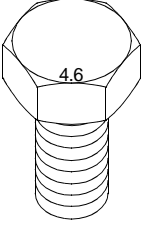
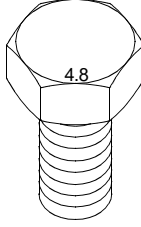
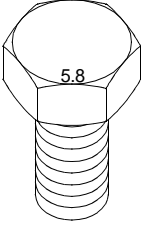
INITIAL SETUP:

Personnel Required

Engineer 88L

CABLE AND WIRING DIAGRAMS INTRODUCTION

Scope

This work package provides the cable lists, wiring lists and illustrations necessary for maintenance, troubleshooting and repair of the Causeway Ferry (CF). Diagrams provide the identification of each wire to be connected, by color code or wire number as applicable. The diagrams show the location of each pertinent terminal and/or position.

The same diagram may be referenced at different times as it applies to instructions within the appropriate maintenance chapter (Unit Level, Direct Support, or General Support).

The one line diagram, schematic and wiring diagram fold out illustrations can be located after the alphabetical index in this manual.

LIST OF FIGURES AND TABLES

Figure/Table	Description	WP/Page
Figure 1, Sheet 1	Cable List, Operators Cab Cable P24-1	0183 00 007
Figure 1, Sheet 2	Cable List, Operators Cab Cable P24-2	0183 00 008
Figure 1, Sheet 3	Cable List, Operators Cab Cable P24-3	0183 00 009
Figure 1, Sheet 4	Cable List, Operators Cab Cable P24-5	0183 00 010
Figure 1, Sheet 5	Cable List, Operators Cab Cable P24-6	0183 00 011
Figure 1, Sheet 6	Cable List, Operators Cab Cable P12-2	0183 00 012
Figure 1, Sheet 7	Cable List, Operators Cab Cable R-RA1	0183 00 013
Figure 1, Sheet 8	Cable List, Operators Cab Cable R-RA1/1	0183 00 014
Figure 1, Sheet 9	Cable List, Operators Cab Cable R-RA2	0183 00 015
Figure 1, Sheet 10	Cable List, Operators Cab Cable P24-7	0183 00 016
Figure 1, Sheet 11	Cable List, Operators Cab Cable P24-8	0183 00 017
Figure 1, Sheet 12	Cable List, Operators Cab Cable P24-9	0183 00 018
Figure 1, Sheet 13	Cable List, Operators Cab Cable NH-1	0183 00 019
Figure 1, Sheet 14	Cable List, Operators Cab Cable P24-4	0183 00 020
Figure 1, Sheet 15	Cable List, Operators Cab Cable P24-10	0183 00 021
Figure 1, Sheet 16	Cable List, Operators Cab Cable P24-11	0183 00 023
Figure 2, Sheet 1	Cable List, Propulsion Module, Cable P24-1	0183 00 024
Figure 2, Sheet 2	Cable List, Propulsion Module, Cable P24-2	0183 00 025
Figure 2, Sheet 3	Cable List, Propulsion Module, Cable P24-3	0183 00 026
Figure 2, Sheet 4	Cable List, Propulsion Module, Cable P24-4	0183 00 027
Figure 2, Sheet 5	Cable List, Propulsion Module, Cable P24-5	0183 00 028
Figure 2, Sheet 6	Cable List, Propulsion Module, Cable P24-6	0183 00 029
Figure 2, Sheet 7	Cable List, Propulsion Module, Cable P24-7-1 & 7-2	0183 00 030
Figure 2, Sheet 8	Cable List, Propulsion Module, Cable P24-8	0183 00 031
Figure 2, Sheet 9	Cable List, Propulsion Module, Cable P24-9	0183 00 032
Figure 2, Sheet 10	Cable List, Propulsion Module, Cable P24-10	0183 00 033

LIST OF FIGURES AND TABLES (CONT'D)

Figure/Table	Description	WP/Page
Figure 2, Sheet 11	Cable List, Propulsion Module, Cable P24-11	0183 00 034
Figure 2, Sheet 12	Cable List, Propulsion Module, Cable P24-12.....	0183 00 035
Figure 2, Sheet 13	Cable List, Propulsion Module, Cable P24-13.....	0183 00 036
Figure 2, Sheet 14	Cable List, Propulsion Module, Cable P24-14.....	0183 00 037
Figure 2, Sheet 15	Cable List, Propulsion Module, Cable B1 and B2	0183 00 038
Figure 2, Sheet 16	Cable List, Propulsion Module, Cable B3 thru B6	0183 00 039
Figure 2, Sheet 17	Cable List, Propulsion Module, Cable KMB-1.....	0183 00 040
Figure 2, Sheet 18	Cable List, Propulsion Module, Cable KMB-2.....	0183 00 041
Figure 2, Sheet 19	Cable List, Propulsion Module, Cable KMB-3.....	0183 00 042
Figure 2, Sheet 20	Cable List, Propulsion Module, Cable CF-1	0183 00 043
Figure 2, Sheet 21	Cable List, Propulsion Module, Cable CF-2.....	0183 00 044
Figure 2, Sheet 22	Cable List, Propulsion Module, Cable CF-5	0183 00 045
Figure 2, Sheet 23	Cable List, Propulsion Module, Cable CCBP-1.....	0183 00 046
Figure 2, Sheet 24	Cable List, Propulsion Module, Cable CFD-1	0183 00 047
Figure 2, Sheet 25	Cable List, Propulsion Module, Cable CFD-2.....	0183 00 048
Figure 2, Sheet 26	Cable List, Propulsion Module, Cable CFD-3.....	0183 00 049
Figure 2, Sheet 27	Cable List, Propulsion Module, Cable CFD-4.....	0183 00 050
Figure 2, Sheet 28	Cable List, Propulsion Module, Cable CFD-5.....	0183 00 051
Figure 2, Sheet 29	Cable List, Propulsion Module, Cable CFD-6.....	0183 00 052
Figure 2, Sheet 30	Cable List, Propulsion Module, Cable CFD-7.....	0183 00 053
Figure 2, Sheet 31	Cable List, Propulsion Module, Cable CFD-8.....	0183 00 054
Figure 2, Sheet 32	Cable List, Propulsion Module, Cable CFR-1	0183 00 055
Figure 2, Sheet 33	Cable List, Propulsion Module, Cable KEH-1.....	0183 00 056
Figure 2, Sheet 34	Cable List, Propulsion Module, Cable KEH-2.....	0183 00 057
Figure 2, Sheet 35	Cable List, Propulsion Module, Cable KL-2	0183 00 058
Figure 2, Sheet 36	Cable List, Propulsion Module, Cable KL-3	0183 00 059
Figure 2, Sheet 37	Cable List, Propulsion Module, Cable KL-4	0183 00 060
Figure 2, Sheet 38	Cable List, Propulsion Module, Cable KL-5	0183 00 061
Figure 2, Sheet 39	Cable List, Propulsion Module, Cable KL-6	0183 00 062
Figure 2, Sheet 40	Cable List, Propulsion Module, Cable KL-7	0183 00 063
Figure 2, Sheet 41	Cable List, Propulsion Module, Cable KL-8	0183 00 064
Figure 2, Sheet 42	Cable List, Propulsion Module, Cable HPU-1.....	0183 00 065
Figure 2, Sheet 43	Cable List, Propulsion Module, Cable VF-1.....	0183 00 066
Table 1	Circuit Breaker Panel A6, External Connections Wiring List (A).....	0183 00 067
Table 2	Circuit Breaker Panel A6, External Connections Wiring List (B).....	0183 00 068
Table 3	Bilge Pump Control Assembly A5, and Rear View, Internal Wiring List	0183 00 070
Table 4	Single Bilge Pump Control A7, Internal Wiring List.....	0183 00 073
Table 5	Engine Junction Box Assembly A4, Internal Wiring List.....	0183 00 075
Table 6	Engine Junction Box Assembly A4, External Wire List.....	0183 00 076
Table 7	Power Module Junction Box A3, Internal Wiring List	0183 00 077
Table 8	Vent Fan Relay Assembly A8, Wire Internal Connections	0183 00 080
Table 9	Mast, Enclosure Wiring List	0183 00 081
Table 10	Navigation Lights Terminal Box Wiring List and Rear View.....	0183 00 088
Table 11	Middle Control Panel, Wiring List.....	0183 00 091
Table 12	Lower Control Panel, Wiring List.....	0183 00 096
Table 13	Terminal Strip A4 Assembly, Wiring List.....	0183 00 102
Table 14	Operators Cab Circuit Breaker Panel A3, Internal Connections.....	0183 00 115
Table 15	Operators Cab Circuit Breaker Panel A3, External Connections	0183 00 117

LIST OF FIGURES AND TABLES (CONT'D)

Figure/Table	Description	WP/Page
Table 16	Thruster Direction/Auxiliary Battery Junction Box A9, Pass Through Terminations	0183 00 118
Table 17	Thruster Direction/Auxiliary Battery Junction Box A9, Internal Wire Connections	0183 00 118
Table 18	Starboard Receptacle A5 Assembly, Wire Connections	0183 00 120
Table 19	Starboard Receptacle A6 Assembly, Wire Connections	0183 00 124
Table 20	Module Electrical Interconnect Assembly	0183 00 128

LIST OF ABBREVIATIONS/ACRONYMS

The abbreviations used in this work package are in accordance with ASME Y14.38-1999, except when the abbreviation stands for a marking actually found in the equipment.

Abbreviation/Acronym Name

A or AMPS	Amperes
AC	Alternating Current
ACT.	Actuator
AM	Ammeter
ANT	Antenna
ASSY	Assembly
AUX	Auxiliary
AWG	American Wire Gage
BATT or BT	Battery
BLK or BK	Black
BNC	Bayonet Connector
BRN	Brown
BU	Blue
CB	Circuit Board
CCW	Counterclockwise
CW	Clockwise
CF	Causeway Ferry
CO2	Carbon Dioxide
COND.	Condition
CONN	Connection or Connector
D	Diode
DC	Direct Current
DET	Detector
DIR	Direction
DSC	Digital Selective Caller
EMER.	Emergency
EMI	Electromagnetic Interference
ENCL.	Enclosure
ENG.	Engine
E-STOP	Emergency Stop
FLD	Field
FO PRESS.	Fuel Oil Pressure
FT	Foot or Feet
FWD	Forward
ga	Gauge
GFE	Government Furnished Equipment
GN or GRN	Green
GND	Ground
GOV.	Governor
HTR	Heater
HYD.	Hydraulic
IAW	In Accordance With
IN.	Inch
IND.	Indicator
IS.	Isolator
J or JUNC.	Junction
JB	Junction Box

LIST OF ABBREVIATIONS/ACRONYMS (CONT'D)

Abbreviation/Acronym	Name
LH	Left Hand
LT.	Light
M	Meter
MALF	Malfunction
MAN.	Manual
MAX.	Maximum
MCS	Modular Causeway System
MOD	Module
MT	Meter Transducer
N/A	Not Applicable
NATO	North Atlantic Treaty Organization
NAV	Navigation
NEG.	Negative
NMEA	National Marine Electronic Association
NO. or NOS.	Number or Numbers
O.	Oil
OC	Operators Cab
O.D.	Outside Diameter
O.P	Oil Pressure
OP CAB or OPER CAB	Operators Cab
OR or ORG	Orange
OT	Oil Temperature
OUT.	Outlet
(P)	Port
POS.	Positive
POS	Position
PRESS.	Pressure
PROP.	Proportioning
PWR	Power
RD	Red
RECEPT.	Receptacle
REF	Reference
REG	Regulator
REQ'D	Required
RET	Return
RFI	Radio Frequency Interference
RH	Right Hand
RM.	Room
RPM	Revolutions Per Minute
RT	Right
RT ANG	Right Angle
S or SW.	Switch
SH	Shunt
SHLD	Shield
SHT	Sheet
SINCGARS	Single Channel Ground and Airborne Radio
SOL	Solenoid
(S) or STBD.	Starboard
STD	Standard
SW	Switch
SYNCHRO.	Synchronization

LIST OF ABBREVIATIONS/ACRONYMS (CONT'D)

Abbreviation/Acronym	Name
TACH	Tachometer
TB	Terminal Board
TEMP	Temperature
TERM	Terminal
TERM. BD.	Terminal Board
THRSTR	Thruster
V	Volts
VDC	Volts Direct Current
VF	Vent Fan
VHF-FM	Very High Frequency/Frequency Modulation
VR	Voltage Regulator
W.	Water
W/	With
WH or WHT	White
WSHLD	Windshield
WT	Water Temperature

OPERATORS CAB WIRING LIST

CABLE LIST						
CABLE NUMBER: P24-1						
CABLE TYPE: LSMHOF-14						
O.D.: .635 INCH						
CABLE LENGTH: 10 FEET						
CABLE ENTRY FROM: A4/A3			FROM: CONTROL CONSOLE - A4/A3			
CABLE ENTRY TO: JB1			TO: RADIO SHELF JUNCTION BOX - JB1			
BULKHEAD FITTINGS: T & B			NOTES: 1. CABLE CONNECTS TO BRANCH CABLES IN JB1/TB1			
TERMINATION DATA						
WIRE NO.	WIRE LABEL	COLOR	FROM TERM METHOD	FROM TERM POINT	TO TERM METHOD	TO TERM POINT
1	0	BLACK	WIRE	A4TB05-20	COMPRESSION	TB1-1
2	386	WHITE	TERMINAL LUG	A4TB05-3	COMPRESSION	TB1-2
3	0	RED	WIRE	A4TB11	COMPRESSION	TB1-3
4	388	GREEN	TERMINAL LUG	A4TB05-6	COMPRESSION	TB1-4
5	0	ORG	WIRE	A4TB11	COMPRESSION	TB1-5
6	383	BLUE	TERMINAL LUG	A4TB05-5	COMPRESSION	TB1-6
7	0	WH/BK	WIRE	A4TB11	COMPRESSION	TB1-7
8	392	RD/BK	TERMINAL LUG	A3CB6-2	COMPRESSION	TB1-8
9	0	GN/BK	WIRE	A4TB11	COMPRESSION	TB1-9
10	393	OR/BK	TERMINAL LUG	A3CB7-2	COMPRESSION	TB1-10
11	0	BU/BK	WIRE	A4TB11	COMPRESSION	TB1-11
12	442	BK/WH	TERMINAL LUG	A4TB05-15	COMPRESSION	TB1-12
13	SPARE	RD/WH				
14	SPARE	GN/WH				

Figure 1. Sheet 1 Operators Cab Cable List
(Sheet 1 of 16)

CABLE LIST						
CABLE NUMBER: P24-2						
CABLE TYPE: 16-2S0 (SHIELD)						
O.D.: .360 INCH						
CABLE LENGTH: 3 FEET						
CABLE ENTRY FROM: JB1 (IT.133)			FROM: RADIO SHELF - JB1			
CABLE ENTRY TO: B3			TO: DEFROSTER FAN MOTOR - B3			
BULKHEAD FITTINGS: SIZE B STUFFING TUBE @ SHELF T & B LIQUIDTIGHT AT JB1			NOTES: 1. CABLE SHIELD GROUNDED AT STUFFING TUBE IN SHELF REFER TO LSI DWG. E13441, DETAIL A-7. 2. CONNECTIONS TO MOTOR SHALL BE MADE IN DEFROSTER CASE. DISCONNECT MOTOR LEAD FROM CASE AND TERMINATE TO LEAD (0) OF THIS CABLE.			
TERMINATION DATA						
WIRE NO.	WIRE LABEL	COLOR	FROM TERM METHOD	FROM TERM POINT	TO TERM METHOD	TO TERM POINT
1	442	BLACK	COMPRESSION	TB1-12	WIRE NUT	B3-1
2	0	WHITE	COMPRESSION	TB1-11	WIRE NUT	B3-2

Figure 1. Sheet 2 Operators Cab Cable List
(Sheet 2 of 16)

CABLE LIST						
CABLE NUMBER: P24-3						
CABLE TYPE: LS2SJ-16						
O.D.: .310 INCH						
CABLE LENGTH: 6 FEET						
CABLE ENTRY FROM: JB1			FROM: RADIO SHELF - JB1			
CABLE ENTRY TO: J5			TO: SPOTLIGHT, RECEPTACLE ON TOP OF OPERATORS CAB			
BULKHEAD FITTINGS: ROOF RECEPTACLE AND T & B LIQUIDTIGHT AT JB-1			NOTES:			
			TERMINATION DATA			
WIRE NO.	WIRE LABEL	COLOR	FROM TERM METHOD	FROM TERM POINT	TO TERM METHOD	TO TERM POINT
1	0	BLACK	COMPRESSION	TB1-5	SOLDER	J5-B
2	383	WHITE	COMPRESSION	TB1-6	SOLDER	J5-A
3	SHIELD	SHIELD			SHIELD TO	BACKSHELL

Figure 1. Sheet 3 Operators Cab Cable List
(Sheet 3 of 16)

CABLE LIST						
CABLE NUMBER: P24-5						
CABLE TYPE: SWE						
O.D.: N/A						
CABLE LENGTH: 8 INCHES						
CABLE ENTRY FROM: VR 1			FROM: DC/DC CONVERTER, RADIO SHELF			
CABLE ENTRY TO: JB1, J2			TO: RADIO SHELF JUNCTION BOX, RADIO RECEPT. - JB1			
BULKHEAD FITTINGS: T & B LIQUIDTIGHT AT JB-1			NOTES: DC/DC CONVERTER FURNISHED WITH VHF-FM RADIO AND MOUNTED ON TOP OF JB1			
TERMINATION DATA						
WIRE NO.	WIRE LABEL	COLOR	FROM TERM METHOD	FROM TERM POINT	TO TERM METHOD	TO TERM POINT
1	(0)	BLACK	WIRE	COMMON	WIRE NUT	TB1-7
2	392	ORG	WIRE	+24 VDC INPUT	WIRE NUT	TB1-8
3	392A	RED	WIRE	+12 VDC OUTPUT	WIRE NUT	NOTE BELOW
			RED WIRE FROM CONVERTER (W/N 392A) IS CONNECTED TO RED WIRE GOING TO VHF/FM DSC RADIO PLUG WITH A WIRE COMPRESSION NUT IN JB1. RELOCATE CONVERTER FUSE TO INSIDE OF JB1. USE BUTT SPLICE TO ADD LENGTH OF WIRE AS NECESSARY. LOOP WIRE 392A TWICE THROUGH FERRITE CORE INSIDE JB1. SECURE WITH TIEDOWN STRAPS .			

Figure 1. Sheet 4 Operators Cab Cable List
(Sheet 4 of 16)

CABLE LIST						
CABLE NUMBER: P12-2						
CABLE TYPE: FURNISHED						
O.D.: N/A						
CABLE LENGTH: 3 FEET						
CABLE ENTRY FROM: JB1			FROM: RADIO SHELF, JUNCTION BOX - JB1			
CABLE ENTRY TO: VHF-FM			TO: RADIO SHELF, VHF-FM TRANSCEIVER			
BULKHEAD FITTINGS: T & B LIQUIDTIGHT AT JB1			NOTES: 1. CABLE AND CONNECTOR FURNISHED WITH RADIO. 2. REFER TO OWNER/OPERATORS MANUAL FOR DETAILED INSTALLATION INSTRUCTIONS. 3. W/N 392A RED CONNECTS WITH WIRE COMPRESSION NUT TO RED WIRE FROM DC/DC CONVERTER, P24-5.			
TERMINATION DATA						
WIRE NO.	WIRE LABEL	COLOR	FROM TERM METHOD	FROM TERM POINT	TO TERM METHOD	TO TERM POINT
(-)	0	BLACK	COMPRESSION	TB1-7	WIRE	(-) OUT (J2-COM)
(+)	392A	RED	WIRE NUT	SEE NOTE 3	WIRE	(+) OUT (J2-+)

Figure 1. Sheet 6 Operators Cab Cable List (Sheet 6 of 16)

CABLE LIST						
CABLE NUMBER: R-RA1						
CABLE TYPE: RG-58/U						
O.D.: .195 INCH						
CABLE LENGTH: 6 FEET						
CABLE ENTRY FROM: VHF-FM			FROM: RADIO SHELF, VHF-FM TRANSCEIVER - ANTENNA CABLE			
CABLE ENTRY TO: JB2			TO: OP CAB INTERIOR, AFT STARBOARD UPPER CORNER - JB2			
BULKHEAD FITTINGS: TERMINAL TUBE ON JB-2			NOTES: 1. CABLE FURNISHED WITH ANTENNA. 2. GROUND CABLE SHIELD AT TERMINAL TUBE ENTRANCE TO JB-2 IAW LSI DWG. E13441. 3. COAXIAL CONNECTORS TO BE INSTALLED BY EXPERIENCED TECHNICIAN			
TERMINATION DATA						
WIRE NO.	WIRE LABEL	COLOR	FROM TERM METHOD	FROM TERM POINT	TO TERM METHOD	TO TERM POINT
	R-RA1	BLACK	PL-259 COAXIAL PLUG	VHF-FM TRANSCEIVER (ANT)	PL-259 COAXIAL PLUG	J-1 (INSIDE) JB-2

Figure 1. Sheet 7 Operators Cab Cable List
(Sheet 7 of 16)

CABLE LIST						
CABLE NUMBER: R-RA1/1						
CABLE TYPE: RG-58/U						
O.D.: .195 INCH						
CABLE LENGTH: 18 INCHES						
CABLE ENTRY FROM: JB-2 J-1			FROM: OP CAB EXTERIOR UPPER AFT STARBOARD CORNER, J-1 OF JB-2			
CABLE ENTRY TO: RA-1			TO: OP CAB ROOF AFT STARBOARD CORNER, VHF-FM ANTENNA			
BULKHEAD FITTINGS:			NOTES: 1. CABLE IS FURNISHED WITH AND CONNECTED TO ANTENNA. 2. CUT EXCESS LENGTH FROM CABLE AND USE FOR R-RA1. 3. COAXIAL CONNECTOR TO BE INSTALLED BY EXPERIENCED TECHNICIAN.			
TERMINATION DATA						
WIRE NO.	WIRE LABEL	COLOR	FROM TERM METHOD	FROM TERM POINT	TO TERM METHOD	TO TERM POINT
	R-RA1	BLACK	PL-259 COAXIAL PLUG	JB-2 J-1	COAXIAL CABLE	ANTENNA

Figure 1. Sheet 8 Operators Cab Cable List
(Sheet 8 of 16)

CABLE LIST						
CABLE NUMBER: R-RA2						
CABLE TYPE: RG-58/U						
O.D.: .195 INCH						
CABLE LENGTH: 6 FEET						
CABLE ENTRY FROM: J-1			FROM: RADIO SHELF, SINGARS TRANSCEIVER, RT			
CABLE ENTRY TO: J-1			TO: AFT LEFT CORNER OF CAB ROOF, AS-3900/VRC ANTENNA			
BULKHEAD FITTINGS: SIZE C STUFFING TUBE ON AFT OPERATORS CAB BULKHEAD			NOTES: 1. CABLE AND CONNECTORS FURNISHED (GFE) WITH RADIO INSTALLATION KIT. 2. CONNECTOR INSTALLATION AND REMOVAL SHALL BE DONE BY EXPERIENCED TECHNICIAN. 3. INSTALL RIGHT ANGLE CONNECTOR AT TOP RIGHT SIDE OF TRANSCEIVER FRONT PANEL TO MATE WITH J-1 ON RADIO. 4. GROUND CABLE SHIELD AT BULKHEAD PENETRATION.			
TERMINATION DATA						
WIRE NO.	WIRE LABEL	COLOR	FROM TERM METHOD	FROM TERM POINT	TO TERM METHOD	TO TERM POINT
	R-RA2	BLACK	BNC (RT ANG)	RT J-1	BNC STRAIGHT	AS-3900 J-1

Figure 1. Sheet 9 Operators Cab Cable List
(Sheet 9 of 16)

CABLE LIST						
CABLE NUMBER: P24-7						
CABLE TYPE: LSDHOF-3						
O.D.: .425 INCH						
CABLE LENGTH: 4 FEET						
CABLE ENTRY FROM: COMPASS			FROM: CONSOLE TOP, CENTER, MAGNETIC COMPASS			
CABLE ENTRY TO: A4TB5			TO: CONTROL CONSOLE INTERIOR, TERMINAL BOARD ASSEMBLY			
BULKHEAD FITTINGS: GROMMET @ CONSOLE TOP (JOINS CABLE P12-1)			NOTES: 1. CABLE FURNISHED WITH COMPASS IS 18 INCHES LONG. USE BUTT CONNECTORS TO CONNECT TO VESSEL CABLING INSIDE CONSOLE.			
TERMINATION DATA						
WIRE NO.	WIRE LABEL	COLOR	FROM TERM METHOD	FROM TERM POINT	TO TERM METHOD	TO TERM POINT
1	(0)	BLACK	WIRE	COMPASS CABLE	TERMINAL LUG	A4TB5-20
2	375A	WHITE	WIRE	COMPASS CABLE	TERMINAL LUG	A4TB5-17
			INSTALL SUPPLIED RESISTOR BETWEEN A4TB5-19 AND A4TB5-17.			

Figure 1. Sheet 10 Operators Cab Cable List
(Sheet 10 of 16)

CABLE LIST						
CABLE NUMBER: P24-8						
CABLE TYPE: LSDHOF-4						
O.D.: .460 INCH						
CABLE LENGTH: 8 FEET						
CABLE ENTRY FROM: A3/A4			FROM: CONTROL CONSOLE INTERIOR, CB PANEL & TERM. BD. ASSY			
CABLE ENTRY TO: A7			TO: MAST ENCL. ASSY A7 (NAV. LIGHT SW. BOX)			
BULKHEAD FITTINGS:			NOTES: W/N 381 FROM A3 CB1-2 TO A4TB9-10			
TERMINATION DATA						
WIRE NO.	WIRE LABEL	COLOR	FROM TERM METHOD	FROM TERM POINT	TO TERM METHOD	TO TERM POINT
1	(0)	BLACK	WIRE	A4TB11	TERM LUG	TB6-A11
2	381	WHITE	TERMINAL LUG	A4TB9-10	TERM LUG	TB6-A12

Figure 1. Sheet 11 Operators Cab Cable List
(Sheet 11 of 16)

CABLE LIST						
CABLE NUMBER: P24-9						
CABLE TYPE: LSTHOF-3						
O.D.: .450 INCH						
CABLE LENGTH: 5 FEET						
CABLE ENTRY FROM: A4TB05			FROM: CONTROL CONSOLE, TERMINAL BOARD ASSY.			
CABLE ENTRY TO: B1A/B1B			TO: CONTROL CONSOLE INTERIOR, HEATER FAN MOTORS			
BULKHEAD FITTINGS:			NOTES: 1. TERMINATE CABLE DIRECTLY TO MOTOR LEADS. DISCONNECT MOTOR LEADS TO (INTERNAL) CASE OF HEATER. CONNECT THESE LEADS TO (0) OF CABLE -24-9.			
TERMINATION DATA						
WIRE NO.	WIRE LABEL	COLOR	FROM TERM METHOD	FROM TERM POINT	TO TERM METHOD	TO TERM POINT
1	(0)	BLACK	COMPRESSION	A4TB11	WIRE NUT	B1A/B COMMON
2	390	WHITE	TERMINAL LUG	A4TB05-07	WIRE NUT	B1A POSITIVE
3	391	RED	TERMINAL LUG	A4TB05-08	WIRE NUT	B1B POSITIVE

Figure 1. Sheet 12 Operators Cab Cable List
(Sheet 12 of 16)

CABLE LIST						
CABLE NUMBER: P24-4						
CABLE TYPE: 16-2S0 (SHIELD)						
O.D.: .360 INCH						
CABLE LENGTH: 3 FEET						
CABLE ENTRY FROM: JB1			FROM: RADIO SHELF - JB-1			
CABLE ENTRY TO: B2			TO: WINDSHIELD WIPER MOTOR			
BULKHEAD FITTINGS: T & B LIQUIDTIGHT AT JB1			NOTES: 1. GROUND SHIELD TO CABINET AT CONNECTOR.			
TERMINATION DATA						
WIRE NO.	WIRE LABEL	COLOR	FROM TERM METHOD	FROM TERM POINT	TO TERM METHOD	TO TERM POINT
1	0	BLACK	COMPRESSION	TB1-3	TERMINAL LUG	B2-2
2	388	WHITE	COMPRESSION	TB1-4	TERMINAL LUG	B2-1

Figure 1. Sheet 14 Operators Cab Cable List
(Sheet 14 of 16)

CABLE LIST						
CABLE NUMBER: P24-10						
CABLE TYPE: LSMSCS-24						
O.D.:						
CABLE LENGTH: 10 FEET						
CABLE ENTRY FROM: A7			FROM: MAST ENCL. ASSY. A7 (NAV. LIGHT SW. BOX)			
CABLE ENTRY TO: J1			TO: OPERATORS CAB RECEPTACLE J1			
BULKHEAD FITTINGS:			NOTES: * COMPRESSION TYPE FITTINGS			
TERMINATION DATA						
WIRE NO.	WIRE LABEL	COLOR	FROM TERM METHOD	FROM TERM POINT	TO TERM METHOD	TO TERM POINT
1	501	BLACK		TB1-A11	PINS	J1-1
2	503	WHITE		TB1-B14	PINS	J1-2
3	504	RED		TB2-A3	PINS	J1-3
4	506	GREEN		TB2-B6	PINS	J1-4
5	507	ORG		TB2-A14	PINS	J1-5
6	509	BLUE		TB2-B17	PINS	J1-6
7	510	WH/BK		TB3-A4	PINS	J1-7
8	512	RD/BK		TB3-B7	PINS	J1-8
9	513	GN/BK		TB3-A15	PINS	J1-9
10	518	OR/BK		TB4-B8	PINS	J1-10
11	518B	BU/BK		TB4-A16	PINS	J1-11
12	520	BK/WH		TB4-B19	PINS	J1-12
13	520B	RD/WH		TB5-A7	PINS	J1-13
14	522	GN/WH		TB5-B10	PINS	J1-14
15	522B	BL/WH		TB5-A18	PINS	J1-15
16	SPARE	BK/RD		---	PINS	J1-16
17	SPARE	WH/RD		---	PINDS	J1-17
18	0	OR/RD		TB6-A8	PINS	J1-18
19	0	BL/RD		TB6-A8	PINS	J1-19
20	0	RD/GN		TB6-A9	PINS	J1-20

CABLE LIST (Continued)						
CABLE NUMBER: P24-10						
CABLE TYPE: LSMSCS-24						
O.D.:						
CABLE LENGTH: 10 FEET						
CABLE ENTRY FROM: A7			FROM: MAST ENCL. ASSY. A7 (NAV. LIGHT SW. BOX)			
CABLE ENTRY TO: J1			TO: OPERATORS CAB RECEPTACLE J1			
BULKHEAD FITTINGS:			NOTES: * COMPRESSION TYPE FITTINGS			
TERMINATION DATA						
WIRE NO.	WIRE LABEL	COLOR	FROM TERM METHOD	FROM TERM POINT	TO TERM METHOD	TO TERM POINT
21	0	OR/GN		TB6-A10	PINS	J1-21
22	SPARE	BK/WH/RD		---	PINS	J1-22
23	SPARE	WH/BK/RD		---	PINS	J1-23
24	SPARE	RD/BK/WH		---	PINS	J1-24
25	SHLD	SHLD			SHLD TO	BACKSHELL

Figure 1. Sheet 15 Operators Cab Cable List
(Sheet 15 of 16)

CABLE LIST						
CABLE NUMBER: P24-11						
CABLE TYPE: LS3SJ-16						
O.D.: .340 INCH						
CABLE LENGTH: 15 FEET						
CABLE ENTRY FROM: LT. SW. BOX A7			FROM: MAST ENCL. ASSY. A7 (NAV. LIGHT SW. BOX)			
CABLE ENTRY TO: J2			TO: AFT MAST RECEPTACLE J2			
BULKHEAD FITTINGS:			NOTES:			
			TERMINATION DATA			
WIRE NO.	WIRE LABEL	COLOR	FROM TERM METHOD	FROM TERM POINT	TO TERM METHOD	TO TERM POINT
1	0	BLACK	COMPRESSION	TB6-A7	PINS	3J2-B
2	515	WHITE	COMPRESSION	TB3-B18	PINS	3J2-A
3	516	RED OR GREEN	COMPRESSION	TB4-A5	PINS	3J2-C
4	SHLD	SHLD	---	---	SHLD TO	BACKSHELL

Figure 1. Sheet 16 Operators Cab Cable List
(Sheet 16 of 16)

CABLE LIST						
CABLE NUMBER: P24-1						
CABLE TYPE: SWE						
O.D.:						
CABLE LENGTH: 4 FEET						
CABLE ENTRY FROM: G1			FROM: ALTERNATOR			
CABLE ENTRY TO: VR1/A9			TO: VOLTAGE REGULATOR/A9 JUNCTION BOX			
BULKHEAD FITTINGS: NONE			NOTES: CABLE IS FURNISHED WITH VOLTAGE REGULATOR - BROWN LEAD IS BROKEN OUT AND ROUTED TO ENG. JUNC. BOX (A4) IN CABLE P24-2. RED WIRE AND OTHER LEADS FURNISHED ARE CONNECTED TO ALTERNATOR.			
TERMINATION DATA						
WIRE NO.	WIRE LABEL	COLOR	FROM TERM METHOD	FROM TERM POINT	TO TERM METHOD	TO TERM POINT
	124	BRN	SEE SHT.3	A4 (TB1-13)	COMPRESSION	TB1-4
	+24	RED	E20908-1	G1-OUT(+)	COMPRESSION	TB1-5
	131	BLUE	FURNISHED	G1-F	COMPRESSION	TB1-1
	130	ORANGE	FURNISHED	G1-AC	COMPRESSION	TB1-2
	0	BLACK	FURNISHED	G1-GND	COMPRESSION	TB1-3
	132	WHITE	20909-1	G1-AC	COMPRESSION	TB1-6
			NOTE: G1 TERMINALS NOT MARKED.			

Figure 2. Propulsion Module Wiring List
(Sheet 1 of 43)

CABLE LIST						
CABLE NUMBER: P24-2						
CABLE TYPE: LSDHOF-4						
O.D.:.460 INCH						
CABLE LENGTH: 12 FEET						
CABLE ENTRY FROM: VR1/G1			FROM: VOLTAGE REGULATOR/ALTERNATOR (A9)			
CABLE ENTRY TO: A4			TO: ENGINE JUNCTION BOX			
BULKHEAD FITTINGS: #2 NYLON TUBE AT A4, 2E PACKING			NOTES: BROWN CONDUCTOR SUPPLIED AS PART OF VOLTAGE REGULATOR/ALTERNATOR WIRING HARNESS IS CONNECTED TO BLACK CONDUCTOR.			
TERMINATION DATA						
WIRE NO.	WIRE LABEL	COLOR	FROM TERM METHOD	FROM TERM POINT	TO TERM METHOD	TO TERM POINT
1	124	BLACK	E13258	TB1-4(BROWN)	E11028-21	TBE-13
2	132	WHITE	E11028-10	TB1-6(WHITE)	E11028-21	TB2-10

Figure 2. Propulsion Module Wiring List
(Sheet 2 of 43)

CABLE LIST						
CABLE NUMBER: P24-3						
CABLE TYPE: 1/0						
O.D.: .910 INCH						
CABLE LENGTH: SEE BELOW						
CABLE ENTRY FROM: A9			FROM: THRUSTER DIR/AUX BATT./VOLTAGE REG/ISOLATOR			
CABLE ENTRY TO: A1B1			TO: ENG. STARTER, A1B1			
BULKHEAD FITTINGS:			NOTES: MAIN WIRES FOR ALTERNATOR CHARGING CURRENT TO +24 VDC SYSTEM			
TERMINATION DATA						
WIRE NO.	WIRE LABEL	COLOR	FROM TERM METHOD	FROM TERM POINT	TO TERM METHOD	TO TERM POINT
1	0	BLACK	E11028-23	ALT GND	E20908-2	STARTER NEG. POST
2	+24	RED	E11028-23	IS1-1	E20908-2	STARTER POS. POST
			NOTES:			
			RED = 96 INCHES			
			BLACK = 60 INCHES			

Figure 2. Propulsion Module Wiring List
(Sheet 3 of 43)

CABLE LIST							
CABLE NUMBER: P24-4							
CABLE TYPE: LSDNW-50							
O.D.: .910 INCH							
CABLE LENGTH: 14 FEET							
CABLE ENTRY FROM: BT&A9			FROM: BATTERY BANK AND A9 JUNCTION BOX				
CABLE ENTRY TO: A6			TO: POWER MODULE CIRCUIT BREAKER BOX				
BULKHEAD FITTINGS: #5 NYLON TUBE AT A6, 5D PACKING			NOTES: CONDUCTORS ARE CLAMPED IN TERMINAL BLOCK AS AT A6.				
TERMINATION DATA							
WIRE NO.	WIRE LABEL	COLOR	FROM TERM METHOD	FROM TERM POINT	TO TERM METHOD	TO TERM POINT	
1	0	BLACK	E20838-2	BT2 NEG	WIRE	TB4-(*)	
2	+24	WHITE	E20838-2	A95H1-L+	WIRE	TB1-1	
			NOTE: (*) TB4 TERMINAL BLOCK CONNECTIONS TO(0) CONNECT TO AN OPEN TERMINAL POINT.				

Figure 2. Propulsion Module Wiring List
(Sheet 4 of 43)

CABLE LIST						
CABLE NUMBER: P24-5						
CABLE TYPE: LSDHOF-4						
O.D.: .460 INCH						
CABLE LENGTH: 5 FEET						
CABLE ENTRY FROM: A6			FROM: POWER MODULE CIRCUIT BREAKER PANEL			
CABLE ENTRY TO: A4			TO: ENG. JUNCTION BOX			
BULKHEAD FITTINGS: 2 NYLON STUFFING TUBE 2E PACKING ASSEMBLY-BOTH ENDS			NOTES: LOAD SIDE OF MAIN CB FOR +24 VDC FEED TO ENG JUNCTION BOX.			
TERMINATION DATA						
WIRE NO.	WIRE LABEL	COLOR	FROM TERM METHOD	FROM TERM POINT	TO TERM METHOD	TO TERM POINT
1	0	BLACK	WIRE	TB4	E11028-1	TB1-20
2	105	WHITE	WIRE	TB2-1	E11028-1	TB1-17

Figure 2. Propulsion Module Wiring List
(Sheet 5 of 43)

CABLE LIST						
CABLE NUMBER: P24-6						
CABLE TYPE: LSDHOF-30						
O.D.: .960 INCH						
CABLE LENGTH: 8 FEET						
CABLE ENTRY FROM: A8			FROM: VENT FAN RELAY, A8			
CABLE ENTRY TO: A6			TO: CIRCUIT BREAKER PANEL, A6			
BULKHEAD FITTINGS: 5 NYLON TUBE 5E PACKING ASSEMBLY-BOTH ENDS			NOTES: FEED FOR VENT FAN MOTOR CIRCUIT.			
TERMINATION DATA						
WIRE NO.	WIRE LABEL	COLOR	FROM TERM METHOD	FROM TERM POINT	TO TERM METHOD	TO TERM POINT
1	0	BLACK	WIRE	TB1	WIRE	TB4
2	133	WHITE	WIRE	K1-1	WIRE	TB2-02
			NOTE: USE TB1 LARGE LUG IN A8 FOR "0" WIRE FOR THIS CABLE. SEE CABLE VF-1.			

Figure 2. Propulsion Module Wiring List
(Sheet 6 of 43)

CABLE LIST						
CABLE NUMBER: P24-7-1 & 7-2						
CABLE TYPE: LSFNW-9						
O.D.: .630 INCH						
CABLE LENGTH: 12 FEET						
CABLE ENTRY FROM: A5			FROM: BILGE PUMP CONTROL PANEL			
CABLE ENTRY TO: A6			TO: PM CIRCUIT BREAKER PANEL			
BULKHEAD FITTINGS: 4 NYLON TUBE 4E INSERT BOTH ENDS			NOTES: TWO CABLES RUN TO SAME LOCATIONS. POWER FEED TO ENGINE COMPARTMENT BILGE PUMP CIRCUIT AND FLOOD ALARM.			
TERMINATION DATA						
WIRE NO.	WIRE LABEL	COLOR	FROM TERM METHOD	FROM TERM POINT	TO TERM METHOD	TO TERM POINT
(7-1) 1	0	BLACK	WIRE	TB3-1	WIRE	TB4
(7-1) 2	0	WHITE	WIRE	TB3-1	WIRE	TB4
(7-1) 3	137	RED	WIRE	TB1-8	WIRE	TB3-3
(7-1) 4	147	GREEN	WIRE	TB2-3	WIRE	TB3-5
(7-2) 1	152	BLACK	WIRE	TB2-8	WIRE	TB3-6
(7-2) 2	157	WHITE	WIRE	TB4-3	WIRE	TB3-7
(7-2) 3	162	RED	WIRE	TB4-8	WIRE	TB3-8
(7-2) 4	167	GREEN	WIRE	TB3-8	WIRE	TB3-9

Figure 2. Propulsion Module Wiring List
(Sheet 7 of 43)

CABLE LIST						
CABLE NUMBER: P24-11						
CABLE TYPE: LS2SJ-18						
O.D.: .310 INCH						
CABLE LENGTH:						
CABLE ENTRY FROM: A2jb2			FROM: THRUSTER CONTROL JUNCTION BOX			
CABLE ENTRY TO: A6			TO: PM CIRCUIT BREAKER PANEL			
BULKHEAD FITTINGS:			NOTES:			
			TERMINATION DATA			
WIRE NO.	WIRE LABEL	COLOR	FROM TERM METHOD	FROM TERM POINT	TO TERM METHOD	TO TERM POINT
1	0	BLACK	COMPRESSION	TB1-2	COMPRESSION	TB4-(*)
2	176	WHITE	COMPRESSION	TB1-1	COMPRESSION	TB3-11
3	SH	SHIELD	COMPRESSION	TB1-SH		NONE
			NOTE: (*)TB4 TERMINAL BLOCK ALL CONNECTIONS (0) CONNECT TO AN OPEN TERMINAL POINT.			

Figure 2. Propulsion Module Wiring List
(Sheet 11 of 43)

CABLE LIST						
CABLE NUMBER: B1, B2						
CABLE TYPE: 5JBX-1011-02P & 03P						
O.D.: .491 INCH						
CABLE LENGTH: SEE BELOW						
CABLE ENTRY FROM: BT			FROM: BATTERY BT 1/BT 2			
CABLE ENTRY TO: A1B1			TO: STARTER/SOLENOID A1 B1			
BULKHEAD FITTINGS:			NOTES: MAIN WIRES FOR ENGINE STARTER.			
TERMINATION DATA						
WIRE NO.	WIRE LABEL	COLOR	FROM TERM METHOD	FROM TERM POINT	TO TERM METHOD	TO TERM POINT
B1	+24	RED 5'	E20838-1	BT1-POS.	320838-1	SOLENOID POS. POST
B2	0	BLACK 4'	E20838-1	BT2-NEG.	E20838-1	STARTER NEG. POST
			NOTE: BLACK = 4' RED = 5'			

Figure 2. Propulsion Module Wiring List
(Sheet 15 of 43)

CABLE LIST						
CABLE NUMBER: B3 THRU B6						
CABLE TYPE: 1/0						
O.D.: .491 INCH						
CABLE LENGTH: AS NEEDED						
CABLE ENTRY FROM: SEE NOTES			FROM: SEE NOTES			
CABLE ENTRY TO: SEE NOTES			TO: SEE NOTES			
BULKHEAD FITTINGS:			NOTES: INTERNAL CABLING ON BATTERY BANK SEE BELOW. REFERENCE E26573 SHT. 8. LABEL ENDS OF CABLES WITH TERMINATION POINT.			
TERMINATION DATA						
WIRE NO.	WIRE LABEL	COLOR	FROM TERM METHOD	FROM TERM POINT	TO TERM METHOD	TO TERM POINT
B3	SEE NOTE	RED	E20838-1	BT1-POS	E20838-1	BT3-POS
B4	SEE NOTE	BLACK	E20838-1	PT1-NEG	E20838-1	BT2-POS
B5	SEE NOTE	BLACK	E20838-1	PT3-NEG	E20838-1	BT4-POS
B6	SEE NOTE	BLACK	E20838-1	BT2-NEG	E20838-1	BT4-NEG
			NOTE:			
			B3	7FT	LONG	
			B4	2FT	LONG	
			B5	2FT	LONG	
			B6	7FT	LONG	

Figure 2. Propulsion Module Wiring List
(Sheet 16 of 43)

CABLE LIST						
CABLE NUMBER: KMB-1						
CABLE TYPE: SWE						
O.D.:						
CABLE LENGTH: 20 FEET						
CABLE ENTRY FROM: A1			FROM: MAIN ENGINE			
CABLE ENTRY TO: A4			TO: ENGINE JUNCTION BOX			
BULKHEAD FITTINGS: TWO SCREW CONNECTOR AT A4			NOTES: KMB-1 IS WIRING HARNESS FURNISHED ON ENGINE SHIELD ON W/NO. 122 & 123 CONNECT TO SHIELD ON KMB-3 W/NO. 119, 120, & 121 AND TO TB1-8.			
TERMINATION DATA						
WIRE NO.	WIRE LABEL	COLOR	FROM TERM METHOD	FROM TERM POINT	TO TERM METHOD	TO TERM POINT
0	0	BLACK		SWE	E11028-17	A4TB1-20
103	103	PURPLE		SWE	E11028-17	A4TB1-10
105	105	WHITE		SWE	E11028-17	A4TB1-17
106	106	WHITE		SWE	E11028-17	A4TB1-18
111	111	RED		SWE	E11028-17	A4TB2-1
113	113	ORANGE		SWE	E11028-17	A4TB2-2
115	115	BROWN		SWE	E11028-17	A4TB2-6
116	116	BROWN		SWE	E11028-17	A4TB1-1
117	117	RED		SWE	E11028-17	A4TB1-2
118	118	BLACK		SWE	E11028-17	A4TB1-3
122	122	WHITE	TIE SHIELD TO TB1-8 FOR W/N 122 & 123	SWE	E11028-17	A4TB1-8
123	123	BLACK		SWE	E11028-17	A4TB1-9
124	124	GREEN		SWE	E11028-17	A4TB1-12
125	125	RED		SWE	E11028-17	A4TB2-7
126	126	GRAY		SWE	E11028-17	A4TB2-8
127	127	BLUE		SWE	E11028-17	A4TB2-9
128	128	YELLOW		SWE	E11028-17	A4TB1-14

Figure 2. Propulsion Module Wiring List
(Sheet 17 of 43)

CABLE LIST						
CABLE NUMBER: KMB-2						
CABLE TYPE: LSMHOF-14						
O.D.: .635 INCH						
CABLE LENGTH: 20 FEET						
CABLE ENTRY FROM: A4			FROM: ENGINE JUNCTION BOX, A4			
CABLE ENTRY TO: A3			TO: POWER MODULE JUNCTION BOX, A3			
BULKHEAD FITTINGS: #4 NYLON TUBE 4E INSERT BOTH ENDS			NOTES:			
TERMINATION DATA						
WIRE NO.	WIRE LABEL	COLOR	FROM TERM METHOD	FROM TERM POINT	TO TERM METHOD	TO TERM POINT
1	104	BLACK	E11028-1	TB1-16	E11028-1	TB1-8
2	111	WHITE	E11028-1	TB2-1	E11028-1	TB1-4
3	113	RED	E11028-1	TB2-2	E11028-1	TB1-2
4	115	GREEN	E11028-1	TB2-06	E11028-1	TB1-6
5	124	ORANGE	E11028-1	TB1-13	E11028-1	TB1-7
6	125	BLUE	E11028-1	TB2-7	E11028-1	TB3-14
7	126	WHITE/ BLACK	E11028-1	TB2-8	E11028-1	TB3-15
8	127	RED/ BLACK	E11028-1	TB2-9	E11028-1	TB3-16
9	129	GREEN/ BLACK	E11028-1	TB1-15	E11028-1	TB1-9
10	132	ORANGE/ BLACK	E11028-1	TB2-10	E11028-1	TB3-17
11	133	BLUE/ BLACK	E11028-1	TB-2-3	E11028-1	TB2-20
12	134	BLACK/ WHITE	E11028-1	TB2-4	E11028-1	TB1-14
13	180	RED/ WHITE	E11028-1	TB2-5	E11028-1	TB2-11
14	178	GREEN/ WHITE	E11028-1	TB1-11	E11028-1	TB2-15

Figure 2. Propulsion Module Wiring List
(Sheet 18 of 43)

CABLE LIST						
CABLE NUMBER: CF-1						
CABLE TYPE: LSTHOF-3						
O.D.: .450 INCH						
CABLE LENGTH: 3 FEET						
CABLE ENTRY FROM: A5			FROM: BILGE PUMP CONTROL PANEL			
CABLE ENTRY TO: S9			TO: ENGINE ROOM FIRE DETECTOR			
BULKHEAD FITTINGS: #2 NYLON TUBE 2E PACKING TWO SCREW CONN AT S9			NOTES: 1. CABLE CF-1 CONNECTS IN S9 TO THE SWITCH. 2. REMOVE INSULATORS AND INSTALL HEAT SHRINK TUBING FOR WATERPROOF CONNECTIONS.			
TERMINATION DATA						
WIRE NO.	WIRE LABEL	COLOR	FROM TERM METHOD	FROM TERM POINT	TO TERM METHOD	TO TERM POINT
1	137	BLACK	WIRE	TB1-9	E23808-1	S9-1 (WHITE)
2	SPARE	WHITE				
3	140	RED	WIRE	TB2-5	E23808-1	S9-2 (BLACK)
			NOTE: CONNECT BOTH WHITE WIRES TOGETHER FROM S9 (S9-1) TO W/N 137 OCNNECT BOTH BLACK WIRES TOGETHER FROM S9 (S9-2) TO W/N 140			

Figure 2. Propulsion Module Wiring List
(Sheet 20 of 43)

CABLE LIST						
CABLE NUMBER: CF-2						
CABLE TYPE: LSTHOF3						
O.D.: .450 INCH						
CABLE LENGTH: 25 FEET						
CABLE ENTRY FROM: A7			FROM: FORWARD COMPARTMENT BILGE PUMP CONTROL			
CABLE ENTRY TO: A5			TO: BILGE PUMP CONTROL PANEL			
BULKHEAD FITTINGS: NO. 2 STUFFING TUBE NO. 2E PACKING BOTH ENDS			NOTES:			
TERMINATION DATA						
WIRE NO.	WIRE LABEL	COLOR	FROM TERM METHOD	FROM TERM POINT	TO TERM METHOD	TO TERM POINT
1	138	BLACK	WIRE	TB1-7	WIRE	TB1-2
2	SPARE	WHITE				
3	146	RED	WIRE	TB1-4	WIRE	TB1-7

Figure 2. Propulsion Module Wiring List
(Sheet 21 of 43)

CABLE LIST						
CABLE NUMBER: CCBP-1						
CABLE TYPE: LSMHOF-14						
O.D.: .635 INCH						
CABLE LENGTH: 20 FEET						
CABLE ENTRY FROM: A5			FROM: BILGE PUMP CONTROL PANEL A5			
CABLE ENTRY TO: A3			TO: POWER MODULE JUNCTION BOX A3			
BULKHEAD FITTINGS: #4 NYLON STUFFING TUBE 4E PACKING BOTH ENDS			NOTES:			
TERMINATION DATA						
WIRE NO.	WIRE LABEL	COLOR	FROM TERM METHOD	FROM TERM POINT	TO TERM METHOD	TO TERM POINT
1	SPARE	BLACK				
2	SPARE	WHITE				
3	139	RED	WIRE	TB1-10	E11028-1	TB1-16
4	141	GREEN	WIRE	TB1-6	E11028-1	TB1-17
5	148	ORANGE	WIRE	TB2-5	E11028-1	TB1-20
6	150	BLUE	WIRE	TB2-1	E11028-1	TB2-1
7	153	WHITE/ BLACK	WIRE	TB2-10	E11028-1	TB2-2
8	155	RED/ BLACK	WIRE	TB2-6	E11028-1	TB2-3
9	158	GREEN/ BLACK	WIRE	TB4-5	E11028-1	TB2-4
10	160	ORANGE/ BLACK	WIRE	TB4-1	E11028-1	TB2-5
11	163	BLUE/ BLACK	WIRE	TB4-10	E11028-1	TB2-6
12	165	BLACK/ WHITE	WIRE	TB4-6	E11028-1	TB2-7
13	168	RED/ WHITE	WIRE	TB3-10	E11028-1	TB2-8
14	170	GREEN/ WHITE	WIRE	TB3-6	E11028-1	TB2-9

Figure 2. Propulsion Module Wiring List
(Sheet 23 of 43)

CABLE LIST						
CABLE NUMBER: CFD-1						
CABLE TYPE: LSDHOF-3						
O.D.: .425 INCH						
CABLE LENGTH: 12 FEET						
CABLE ENTRY FROM: A3			FROM: P.M. JUNCTION BOX			
CABLE ENTRY TO: A7			TO: FORWARD COMPARTMENT BILGE PUMP CONTROL			
BULKHEAD FITTINGS: #2 NYLON TUBE 2E PACKING AT BOTH ENDS			NOTES:			
			TERMINATION DATA			
WIRE NO.	WIRE LABEL	COLOR	FROM TERM METHOD	FROM TERM POINT	TO TERM METHOD	TO TERM POINT
1	143	BLACK	E11028-1	TB1-18	WIRE	TB1-5
2	145	WHITE	E11028-1	TB1-19	WIRE	TB1-1

Figure 2. Propulsion Module Wiring List
(Sheet 24 of 43)

CABLE LIST						
CABLE NUMBER: CFD-2						
CABLE TYPE: LSTNW-9						
O.D.: .625 INCH						
CABLE LENGTH: 5 FEET						
CABLE ENTRY FROM: A7			FROM: FORWARD COMPARTMENT BILGE PUMP CONTROL			
CABLE ENTRY TO: JB1			TO: FWD. COMPARTMENT JUNCTION BOX, BILGE PUMP, SWITCH			
BULKHEAD FITTINGS: #4 NYLON TUBE 4E PACKING AT A7. USE TWO SCREW CONNECTOR AT JD1.			NOTES: IN JB1, CFD-2 CONNECTS TO WIRES FROM BILGE PUMP B2, & FLOAT SWITCH S10. OBSERVE POLARITY OF B2, S10 IS NON-POLARIZED.			
TERMINATION DATA						
WIRE NO.	WIRE LABEL	COLOR	FROM TERM METHOD	FROM TERM POINT	TO TERM METHOD	TO TERM POINT
1	0	BLACK	WIRE	TB1-6	E23808-2	B2-1 (BLACK) S10-2
2	143	WHITE	WIRE	TB1-5	E23808-2	B2-2 (BROWN)
3	146	RED	WIRE	TB1-4	E23808-2	S10-1

Figure 2. Propulsion Module Wiring List
(Sheet 25 of 43)

CABLE LIST						
CABLE NUMBER: CFD-3						
CABLE TYPE: LSTNW-9						
O.D.: .625 INCH						
CABLE LENGTH: 32 FEET						
CABLE ENTRY FROM: A5			FROM: BILGE PUMP CONTROL PANEL, A5			
CABLE ENTRY TO: JB2			TO: FWD. STBD. ENG. RM. JUNCTION BOX 2, B4, S12			
BULKHEAD FITTINGS: #4 NYLON TUBE, 4E PACKING AT A5 TWO SCREW CONNECTOR AT JB2.			NOTES: IN JB2, CFD-3 CONNECTS TO WIRES FROM BILGE PUMP B4, & BILGE SW. S12. OBSERVE POLARITY OF B4, S12 IS NON-POLARIZED.			
TERMINATION DATA						
WIRE NO.	WIRE LABEL	COLOR	FROM TERM METHOD	FROM TERM POINT	TO TERM METHOD	TO TERM POINT
1	0	BLACK	WIRE	TB3-4	E23808-2	B4-1 (BLACK) S12-2
2	153	WHITE	WIRE	TB2-10	E23808-2	B4-2 (BROWN)
3	156	RED	WIRE	TB2-9	E23808-2	S12-1

Figure 2. Propulsion Module Wiring List
(Sheet 26 of 43)

CABLE LIST							
CABLE NUMBER: CFD-4							
CABLE TYPE: LSTNW-9							
O.D.: .625 INCH							
CABLE LENGTH: 25 FEET							
CABLE ENTRY FROM: A5			FROM: BILGE PUMP CONTROL PANEL				
CABLE ENTRY TO: A9			TO: FWD PORT ENG. RM. THRUSTER JUNCTION BOX, A9				
BULKHEAD FITTINGS: #4 NYLON TUBE, 4E PACKING BOTH ENDS. #1 NYLON TUBE, 1B PACKING ON PUMP/FLOAT SWITCH.			NOTES: A9 JUNCTION BOX IS USED AS A PASS THROUGH FOR B3-S11 PUMP/FLOAT SWITCH.				
TERMINATION DATA							
WIRE NO.	WIRE LABEL	COLOR	FROM TERM METHOD	FROM TERM POINT	TO TERM METHOD	TO TERM POINT	
1	0	BLACK	WIRE	TB3-2	E23808-2	TB2-18	
2	148	WHITE	WIRE	TB2-5	E23808-2	TB2-19	
3	151	RED	WIRE	TB2-4	E23808-2	TB2-20	
			NOTE: FROM A9 TO PUMP/PUMP FLOAT SWITCH. THE FOLLOWING CONNECTIONS SHALL BE USED.				
1	0		WIRE	TB2-18	E23808-2	B3-1 (BLACK) S11-2	
2	148		WIRE	TB2-19	E23808-2	B3-2 (BROWN)	
3	151		WIRE	TB2-20	E23808-2	S11-1	

Figure 2. Propulsion Module Wiring List
(Sheet 27 of 43)

CABLE LIST						
CABLE NUMBER: CFD-5						
CABLE TYPE: LSTNW-9						
O.D.: .625 INCH						
CABLE LENGTH: 25 FEET						
CABLE ENTRY FROM: A5			FROM: BILGE PUMP CONTROL PANEL			
CABLE ENTRY TO: JB5			TO: AFT. STBD. ENG. RM. JUNCTION BOX, B6, S14			
BULKHEAD FITTINGS: #4 NYLON TUBE, 4E PACKING AT A5. TWO SCREW CONNECTOR AT JB5.			NOTES: IN JB5 CFD-5 CONNECTS TO WIRES FROM BILGE PUMP B6 AND BILGE SWITCH S14, OBSERVE POLARITY OF B6, S14 IS NON-POLARIZED.			
TERMINATION DATA						
WIRE NO.	WIRE LABEL	COLOR	FROM TERM METHOD	FROM TERM POINT	TO TERM METHOD	TO TERM POINT
1	0	BLACK	WIRE	TB3-2	E23808-2	B6-1 (BLACK) S14-2
2	163	WHITE	WIRE	TB4-10	E23808-2	B6-2 (BROWN)
3	166	RED	WIRE	TB4-9	E23808-2	S14-1

Figure 2. Propulsion Module Wiring List
(Sheet 28 of 43)

CABLE LIST						
CABLE NUMBER: CFD-6						
CABLE TYPE: LSTNW-9						
O.D.: .625 INCH						
CABLE LENGTH: 18 FEET						
CABLE ENTRY FROM: A5			FROM: BILGE PUMP CONTROL PANEL, A5			
CABLE ENTRY TO: JB6			TO: AFT. COMPARTMENT, JUNCTION BOX, JB8			
BULKHEAD FITTINGS: #4 NYLON TUBE 4E PACKING AT A5. TWO SCREW CONNECTOR AT JB6.			NOTES: IN JB6 CFD-6 CONNECTS TO WIRE FROM BILGE PUMP B7 & BILGE SWITCH S15. OBSERVE POLARITY OF B7, S15 IS NON-POLARIZED.			
TERMINATION DATA						
WIRE NO.	WIRE LABEL	COLOR	FROM TERM METHOD	FROM TERM POINT	TO TERM METHOD	TO TERM POINT
1	0	BLACK	WIRE	TB3-5	E23808-2	B7-1 (BLACK) S15-2
2	168	WHITE	WIRE	TB3-10	E23808-2	B7-2 (BROWN)
3	171	RED	WIRE	TB3-9	E23808-2	S15-1

Figure 2. Propulsion Module Wiring List
(Sheet 29 of 43)

CABLE LIST						
CABLE NUMBER: CFD-7						
CABLE TYPE: LSTNW-9						
O.D.: .625 INCH						
CABLE LENGTH: 19 FEET						
CABLE ENTRY FROM: A5			FROM: BILGE PUMP CONTROL PANEL			
CABLE ENTRY TO: JB8			TO: AFT. PORT ENGINE RM. JUNCTION BOX, B5, S13			
BULKHEAD FITTINGS: #4 NYLON TUBE 4E PACKING AT A5. TWO SCREEN CONNECTORS AT JB8.			NOTES: IN JB8, CFD-7 CONNECTS TO WIRES FROM BILGE PUMP B5, & BILGE SWITCH S13. OBSERVE POLARITY OF B5, S13 IS NON-POLARIZED.			
TERMINATION DATA						
WIRE NO.	WIRE LABEL	COLOR	FROM TERM METHOD	FROM TERM POINT	TO TERM METHOD	TO TERM POINT
1	0	BLACK	WIRE	TB3-3	E23808-2	B5-1 (BLACK) S13-2
2	158	WHITE	WIRE	TB4-5	E23808-2	B5-2 (BROWN)
3	161	RED	WIRE	TB4-4	E23808-2	S13-1

Figure 2. Propulsion Module Wiring List
(Sheet 30 of 43)

CABLE LIST						
CABLE NUMBER: CFD-8						
CABLE TYPE: LSMHOF-14						
O.D.: .635 INCH						
CABLE LENGTH: 25 FEET						
CABLE ENTRY FROM: A5			FROM: BILGE PUMP CONTROL PANEL			
CABLE ENTRY TO: A3			TO: PM JUNCTION BOX			
BULKHEAD FITTINGS: #4 STUFFING TUBE #4E PACKING BOTH ENDS			NOTES:			
TERMINATION DATA						
WIRE NO.	WIRE LABEL	COLOR	FROM TERM METHOD	FROM TERM POINT	TO TERM METHOD	TO TERM POINT
1	146	BLACK	WIRE	TB1-7	E11028-21	TB4-1
2	151	WHITE	WIRE	TB2-4	E11028-21	TB4-2
3	156	RED	WIRE	TB2-9	E11028-21	TB4-3
4	161	GREEN	WIRE	TB4-4	E11028-21	TB4-4
5	166	ORANGE	WIRE	TB4-9	E11028-21	TB4-5
6	171	BLUE	WIRE	TB3-9	E11028-21	TB4-6
7	138	WHITE/ BLACK	WIRE	TB1-2	E11028-21	TB4-7
8	138	RED/ BLACK	WIRE	TB5-1	E11028-21	TB4-8
9	138	GREEN/ BLACK	WIRE	TB6-1	E11028-21	TB4-9
10	SPARE	ORANGE/ BLACK	--	--	--	--
11	SPARE	BLUE/ BLACK	--			
12	SPARE	BLACK/ WHITE	--			
13	SPARE	RED/ WHITE	--			
14	SPARE	GREEN/ WHITE	--	--	--	--

Figure 2. Propulsion Module Wiring List
(Sheet 31 of 43)

CABLE LIST						
CABLE NUMBER: CFR-1						
CABLE TYPE: LSFNW-4						
O.D.: .513 INCH						
CABLE LENGTH: 30 FEET						
CABLE ENTRY FROM: A4			FROM: ENGINE JB			
CABLE ENTRY TO: S2			TO: CO ₂ RELEASE SWITCH, FWD. COMPARTMENT			
BULKHEAD FITTINGS: #4			NOTES: THIS CABLE IS CONNECTED TO ONE POLE OF THE CO ₂ RELEASE SWITCH.			
TERMINATION DATA						
WIRE NO.	WIRE LABEL	COLOR	FROM TERM METHOD	FROM TERM POINT	TO TERM METHOD	TO TERM POINT
1	133	BLACK	RING TONGUE	TB2-3	RING TONGUE	S2A COM
2	134	WHITE	RING TONGUE	TB2-4	RING TONGUE	S2A N/C
3	104	RED	RING TONGUE	TB1-16	RING TONGUE	S2B-COM
4	124	GREEN	RING TONGUE	TB1-12	RING TONGUE	S2B-N/O
			NOTE: USE RING TONGUE TERMINALS			

Figure 2. Propulsion Module Wiring List
(Sheet 32 of 43)

CABLE LIST						
CABLE NUMBER: KEH-1						
CABLE TYPE: LS2SJ-18						
O.D.: .310 INCH						
CABLE LENGTH: 14 FEET						
CABLE ENTRY FROM: A3			FROM: POWER MODULE JUNCTION BOX			
CABLE ENTRY TO: L2			TO: CLUTCH SOLENOID (L2)			
BULKHEAD FITTINGS: 2A PACKING, #2 NYLON TUBE @A3 1C PACKING, #1 NYLON TUBE @ SOL. CONNECTION			NOTES: COORDINATOR WITH HYDRAULIC SYSTEM MECHANICS TO IDENTIFY ENGAGE CONNECTIONS.			
TERMINATION DATA						
WIRE NO.	WIRE LABEL	COLOR	FROM TERM METHOD	FROM TERM POINT	TO TERM METHOD	TO TERM POINT
1	0	BLACK	E11028-1	TB1-13	PLUG	L2-2 (0)
2	174	WHITE	E11028-1	TB1-11	PLUG	L2-1 (+)

Figure 2. Propulsion Module Wiring List
(Sheet 33 of 43)

CABLE LIST						
CABLE NUMBER: KEH-2						
CABLE TYPE: LS2SJ-18						
O.D.: .31 INCH						
CABLE LENGTH: 14 FEET						
CABLE ENTRY FROM: A3			FROM: POWER MODULE JUNCTION BOX			
CABLE ENTRY TO: L3			TO: CLUTCH SOLENOID L3			
BULKHEAD FITTINGS: POWER MODULE NO. 2 PACKING NO. 2A PACKING CLUTCH = PLUG CONNECTIONS. NO. 1 STUFFING TUBE NO. 1C PACKING			NOTES: COORDINATE WITH HYDRAULIC SYSTEM MECHANICS TO IDENTIFY DISENGAGE CONNECTION.			
						TERMINATION DATA
WIRE NO.	WIRE LABEL	COLOR	FROM TERM METHOD	FROM TERM POINT	TO TERM METHOD	TO TERM POINT
1	0	BLACK	E11028-1	TB1-13	PLUG	L3-2 (0)
2	175	WHITE	E11028-1	TB1-11	PLUG	L3-1 (+)
3	SHIELD		WIRE LUG	SHIELD CONNECTIONS		

Figure 2. Propulsion Module Wiring List
(Sheet 34 of 43)

CABLE LIST						
CABLE NUMBER: KL-2						
CABLE TYPE: LS4SJ-20						
O.D.: .360 INCH						
CABLE LENGTH: 16 FEET						
CABLE ENTRY FROM: A3			FROM: POWER MODULE J BOX			
CABLE ENTRY TO: A2jb1			TO: ON THRUSTER - SYNCHRO, A2jb1			
BULKHEAD FITTINGS: #4 NYLON TUBE, 4B PACKING AT A2, TBD AT A2jb1.			NOTES: EQUIPMENT FURNISHED AS PART OF THRUSTER. CONSULT MANUFACTURER'S DATA TO CONFIRM CONNECTIONS.			
TERMINATION DATA						
WIRE NO.	WIRE LABEL	COLOR	FROM TERM METHOD	FROM TERM POINT	TO TERM METHOD	TO TERM POINT
1	182	BLACK	E11028-1	TB3-10	COMPRESSION	1
2	183	WHITE	E11028-1	TB3-11	COMPRESSION	2
3	185	RED	E11028-1	TB3-6	COMPRESSION	3
4	186	GREEN	E11028-1	TB3-7	COMPRESSION	4
5	SHIELD	SHIELD	E11028-1	TB3-13		

Figure 2. Propulsion Module Wiring List
(Sheet 35 of 43)

CABLE LIST						
CABLE NUMBER: KL-3						
CABLE TYPE: LS2SJ-18						
O.D.: .310 INCH						
CABLE LENGTH: 15 FEET						
CABLE ENTRY FROM: A9			FROM: THRUSTER DIR/AUX. BATT./VOLTAGE REG.			
CABLE ENTRY TO: A3			TO: POWER MODULE JUNCTION BOX			
BULKHEAD FITTINGS: STUFFING TUBE #2 PACKING #2A BOTH ENDS			NOTES:			
TERMINATION DATA						
WIRE NO.	WIRE LABEL	COLOR	FROM TERM METHOD	FROM TERM POINT	TO TERM METHOD	TO TERM POINT
1	205	BLACK	E11028-1	TB2-6	E11028-1	TB2-18
2	206	WHITE	E11028-1	TB2-7	E11028-1	TB2-19
3	SHIELD	--				

Figure 2. Propulsion Module Wiring List
(Sheet 36 of 43)

CABLE LIST						
CABLE NUMBER: KL-4						
CABLE TYPE: LS3SJ-18						
O.D.: .325 INCH						
CABLE LENGTH: 25 FEET						
CABLE ENTRY FROM: A2jb2			FROM: THRUSTER/JUNCTION BOX (A2jb2)			
CABLE ENTRY TO: A3			TO: POWER MODULE JUNCTION BOX A3			
BULKHEAD FITTINGS: NO. 2 STUFFING TUBE, NO. 2A PACKING, BOTH ENDS			NOTES: INTERFACE CABLING TO CAB FOR THRUSTER CONTROL			
TERMINATION DATA						
WIRE NO.	WIRE LABEL	COLOR	FROM TERM METHOD	FROM TERM POINT	TO TERM METHOD	TO TERM POINT
1	210	BLACK	COMPRESSION	TB1-3	E11028-1	TB3-12
2	211	WHITE	COMPRESSION	TB1-4	E11028-1	TB3-19
3	212	RED	COMPRESSION	TB1-5	E11028-1	TB3-18
4	SHIELD	SHIELD	COMPRESSION	SHIELD	E11028-1	TB3-13

Figure 2. Propulsion Module Wiring List
(Sheet 37 of 43)

CABLE LIST						
CABLE NUMBER: KL-5						
CABLE TYPE: LS2SJ-18						
O.D.: .310 INCH						
CABLE LENGTH: 8 FEET						
CABLE ENTRY FROM: A2jb1			FROM: HYD. CONTROL/SOL. A			
CABLE ENTRY TO: A2jb2			TO: THRUSTER CONTROL			
BULKHEAD FITTINGS: HYD. CONTROL PLUG SOL. A THRUSTER CONTROL NO. 2 STUFFING TUBE NO 2A PACKING			NOTES: THRUSTER ROTATION			
TERMINATION DATA						
WIRE NO.	WIRE LABEL	COLOR	FROM TERM METHOD	FROM TERM POINT	TO TERM METHOD	TO TERM POINT
1	0	BLACK	PLUG	L5-2	COMPRESSION	TN1-9
2	177	WHITE	PLUG	L5-1	COMPRESSION	TB1-8
3	SHIELD	SHIELD	--	--	COMPRESSION	TB1-9/SH

Figure 2. Propulsion Module Wiring List
(Sheet 38 of 43)

CABLE LIST						
CABLE NUMBER: KL-6						
CABLE TYPE: LS2SJ-18						
O.D.: .310 INCH						
CABLE LENGTH: 8 FEET						
CABLE ENTRY FROM: A2jb1			FROM: HYD. CONTROL/SOL. A			
CABLE ENTRY TO: A2jb2			TO: THRUSTER CONTROL			
BULKHEAD FITTINGS: HYD. CONTROL SOL. B			NOTES: THRUSTER ROTATION			
			TERMINATION DATA			
WIRE NO.	WIRE LABEL	COLOR	FROM TERM METHOD	FROM TERM POINT	TO TERM METHOD	TO TERM POINT
1	0	BLACK	PLUG	L4-2	COMPRESSION	TB1-7
2	179	WHITE	PLUG	L4-1	COMPRESSION	TB1-6
3	SHIELD	SHIELD	--	--	COMPRESSION	TB1-7/SH

Figure 2. Propulsion Module Wiring List (Sheet 39 of 43)

CABLE LIST						
CABLE NUMBER: KL-7						
CABLE TYPE: LSDHOF-3						
O.D.: .425 INCH						
CABLE LENGTH: 21 FEET						
CABLE ENTRY FROM: A4			FROM: ENGINE JUNCTION BOX, A4			
CABLE ENTRY TO: L1			TO: COLD START SOLENOID, L1			
BULKHEAD FITTINGS: #2 NYLON TUBE, 2E PACKING AT A4			NOTES:			
TERMINATION DATA						
WIRE NO.	WIRE LABEL	COLOR	FROM TERM METHOD	FROM TERM POINT	TO TERM METHOD	TO TERM POINT
1	103	BLACK	E11028-1	TB1-10	E11028-1	BLUE SOL. POS
2	0	WHITE	E11028-1	TB1-19	E11028-1	BLACK SOL. NEG

Figure 2. Propulsion Module Wiring List
(Sheet 40 of 43)

CABLE LIST						
CABLE NUMBER: KL-8						
CABLE TYPE: LS35J-18						
O.D.: .370 INCH						
CABLE LENGTH: 25 FEET						
CABLE ENTRY FROM: A4			FROM: ENGINE BOX A4			
CABLE ENTRY TO: A2S2			TO: THRUSTER GEARCASE OIL LEVEL			
BULKHEAD FITTINGS:			NOTES:			
TERMINATION DATA						
WIRE NO.	WIRE LABEL	COLOR	FROM TERM METHOD	FROM TERM POINT	TO TERM METHOD	TO TERM POINT
1	180	RED	RING TONGUE	TB2-5	PLUG	C
2	0	BLACK	RING TONGUE	TB1-19	PLUG	B
3	105	WHITE	RING TONGUE	TB1-17	PLUG	A

Figure 2. Propulsion Module Wiring List
(Sheet 41 of 43)

CABLE LIST						
CABLE NUMBER: HPU-1						
CABLE TYPE: LSDHOF-3						
O.D.: .425 INCH						
CABLE LENGTH: 25 FEET						
CABLE ENTRY FROM: A2jb1			FROM: HYD. TANK A2jb1-S1			
CABLE ENTRY TO: A4			TO: ENGINE BOX A4			
BULKHEAD FITTINGS: #2 STUFFING TUBE #2E PACKING @ A4 #1 PACKING #1C PACKING @ HPU CONN.			NOTES:			
TERMINATION DATA						
WIRE NO.	WIRE LABEL	COLOR	FROM TERM METHOD	FROM TERM POINT	TO TERM METHOD	TO TERM POINT
1	178	BLACK	SPLICE	RED WIRE	E11028-1	TB1-11
2	105	WHITE	SPLICE	RED WIRE	E11028-1	TB1-17

Figure 2. Propulsion Module Wiring List
(Sheet 42 of 43)

CABLE LIST						
CABLE NUMBER: VF-1						
CABLE TYPE: LSDHOF-3						
O.D.: .425 INCH						
CABLE LENGTH: 30 FEET						
CABLE ENTRY FROM:			FROM: A3 - PWR MOD JUNCTION BOX - LOCATED FWD (STBD)			
CABLE ENTRY TO:			TO: A8 - VENT FAN RELAY ENCL. LOCATED AFT (PORT)			
BULKHEAD FITTINGS:			NOTES:			
			TERMINATION DATA			
WIRE NO.	WIRE LABEL	COLOR	FROM TERM METHOD	FROM TERM POINT	TO TERM METHOD	TO TERM POINT
	135	BLACK	RING TONGUE	TB1-15	WIRE	K1-5
	133	WHITE	RING TONGUE	TB2-20	WIRE	K1-1

Figure 2. Propulsion Module Wiring List
(Sheet 43 of 43)

Table 1: Circuit Breaker Panel A6 and Rear View, External Connections Wiring List (A).

FROM	TERM	ITEM #	WIRE #	SIZE	TO	TERM	ITEM #	NOTES
TB1	1	-	+24	6	CB1	1	66	-
TB1	2	-	105	8	CB3	1	49	-
TB1	2	-	105	8	CB11	1	49	-
TB1	2	-	105	8	TB2	1	-	-
CB1	2	66	105	6	TB1	2	-	-
CB3	1	49	105	8	CB2	1	49	JUMPER
CB2	1	49	105	8	CB4	1	49	JUMPER
CB4	1	49	105	8	CB5	1	49	JUMPER
CB5	1	49	105	8	CB6	1	49	JUMPER
CB6	1	49	105	8	CB7	1	49	JUMPER
CB11	1	49	105	8	CB13	1	49	JUMPER
CB13	1	49	105	8	CB12	1	49	JUMPER
CB12	1	49	105	8	CB10	1	49	JUMPER
CB10	1	49	105	8	CB9	1	49	JUMPER
CB9	1	49	105	8	CB8	1	49	JUMPER
CB2	2	44	110	14	TB3	1	-	-
CB3	2	49	133	8	TB2	2	-	-
CB4	2	44	137	14	TB3	3	-	-
CB5	2	44	142	14	TB3	4	-	-
CB6	2	44	147	14	TB3	5	-	-
CB7	2	44	152	14	TB3	6	-	-
CB8	2	44	157	14	TB3	7	-	-
CB9	2	44	162	14	TB3	8	-	-
CB10	2	44	167	14	TB3	9	-	-
CB11	2	49	172	8	TB2	3	-	-
CB12	2	44	173	14	TB3	10	-	-
CB13	2	44	176	14	TB3	11	-	-
CB14	1	44	202	14	TB2	4	-	-
CB14	2	44	203	14	TB2	5	-	-

Table 2: Circuit Breaker Panel A6 and Rear View, External Connections Wiring List (B).

WIRE	FROM	TERM	EQUIPMENT	NOTES
0	TB4	ALL	NEGATIVE	ALL GROUNDS TIE HERE
+24	TB1	2	+24 IN	-
105	TB2	1	EMER SHUT DOWN	-
110	TB3	1	ENGINE POWER	-
133	TB2	2	VENT FAN	-
137	TB3	3	ALARMS	-
142	TB3	4	BILGE PUMP 1	-
147	TB3	5	BILGE PUMP 2	-
152	TB3	6	BILGE PUMP 3	-
157	TB3	7	BILGE PUMP 4	-
162	TB3	8	BILGE PUMP 5	-
167	TB3	9	BILGE PUMP 6	-
172	TB2	3	OPERATORS CAB	-
173	TB3	10	CLUTCH CONTROL	-
176	TB3	11	THRUSTER	-
202	TB2	4	THRUSTER INDICATOR	-
203	TB2	5	THRUSTER INDICATOR	-

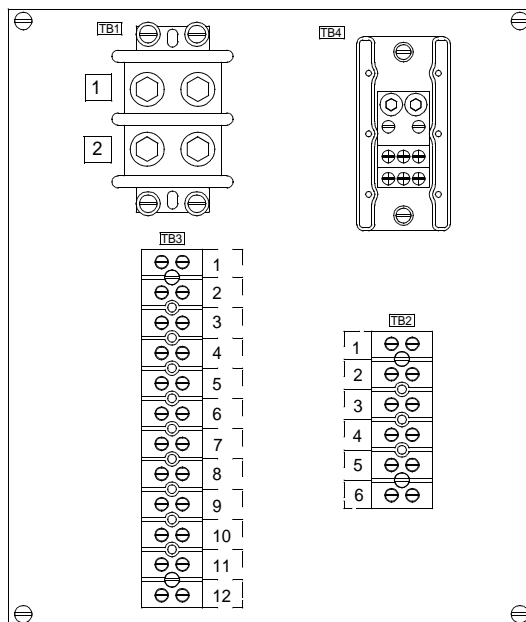

Table 2: Circuit Breaker Panel A6 and Rear View, External Connections Wiring List (B). (Continued)

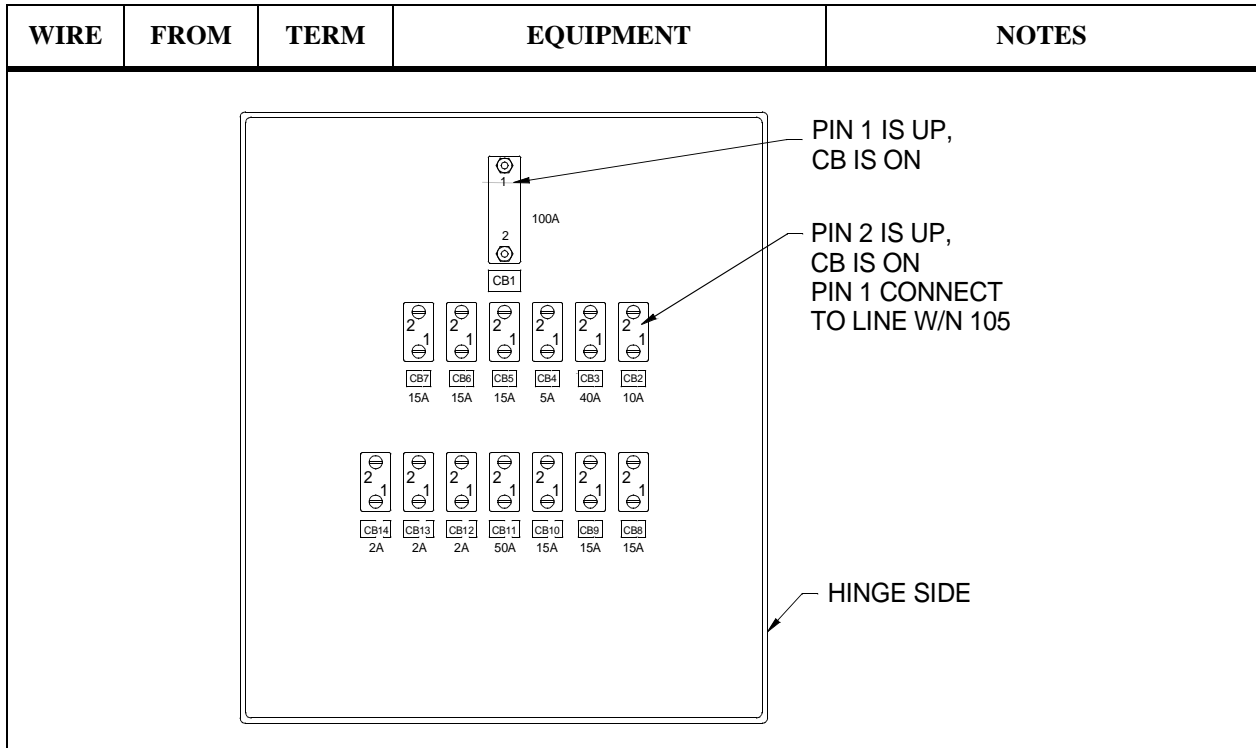

Table 3: Bilge Pump Control Assembly A5 and Rear View, Internal Wiring List.

FROM	TERM	ITEM #	WIRE #	SIZE	TO	TERM	ITEM #	NOTES
TB6	3	-	138	16	TB6	1	-	JUMPER
TB6	1	-	138	16	TB5	1	-	JUMPER
TB5	1	-	138	16	TB5	3	-	JUMPER
TB5	3	-	138	16	TB1	2	-	JUMPER
TB1	2	-	138	16	TB1	3	-	JUMPER
TB1	3	-	138	-	D12	A	29	D12-A
TB1	4	-	171	-	D12	K	29	D12-K
TB1	5	-	140	-	D2	A	29	D2-A
TB1	6	-	141	-	D2	K	29	D2-K
TB1	9	-	137	-	D1	A	29	D1-A
TB1	10	-	139	-	D1	K	29	D1-K
K2	30	8	147	16	TB2	3	-	-
K2	87	8	149	16	TB2	2	29	D3-A
K2	86	8	150	16	TB2	1	29	D3-K

Table 3: Bilge Pump Control Assembly A5 and Rear View, Internal Wiring List. (Continued)

FROM	TERM	ITEM #	WIRE #	SIZE	TO	TERM	ITEM #	NOTES
K2	85	8	151	16	TB2	4	-	-
S1	1	32	147	16	TB2	3	-	-
S1	2	32	148	16	TB2	5	-	-
S1	3	32	149	16	TB2	2	-	-
K3	30	8	152	16	TB2	8	-	-
K3	87	8	154	16	TB2	7	29	D4-A
K3	86	8	155	16	tb2	6	29	D4-K
K3	85	8	156	16	TB2	9	-	-
S2	1	32	152	16	TB2	8	-	-
S2	2	32	153	16	TB2	10	-	-
S2	3	32	154	16	TB2	7	-	-
K4	30	8	157	16	TB4	3	-	-
K4	87	8	159	16	TB4	2	29	D5-A
K4	86	8	160	16	TB4	1	29	D5-K
K4	85	8	161	16	TB4	4	-	-
S3	1	32	157	16	TB4	3	-	-
S3	2	32	258	16	TB4	5	-	-
S3	3	32	159	16	TB4	2	-	-
K5	30	8	162	16	TB4	8	-	-
K5	87	8	164	16	TB4	7	29	D6-A
K5	86	8	165	16	TB4	6	29	D6-K
K5	85	8	166	16	TB4	9	-	-
S4	1	32	162	16	TB4	8	-	-
S4	2	32	163	16	TB4	10	-	-
S4	3	32	164	16	TB4	7	-	-
TB1	8	-	137	16	TB1	9	-	JUMPER
TB3	1	-	0	16	TB3	2	-	JUMPER
TB3	2	-	0	16	TB4	3	-	JUMPER

Table 3: Bilge Pump Control Assembly A5 and Rear View, Internal Wiring List. (Continued)

FROM	TERM	ITEM #	WIRE #	SIZE	TO	TERM	ITEM #	NOTES
TB3	3	-	0	16	TB4	4	-	JUMPER
TB3	4	-	0	16	TB4	5	-	JUMPER
K6	30	8	167	16	TB3	8	-	-
K6	87	8	169	16	TB3	7	29	D7-A
K6	86	8	170	16	TB3	6	29	D7-K
K6	85	8	171	16	TB3	9	-	-
S5	1	32	167	16	TB3	8	-	-
S5	2	32	168	16	TB3	10	-	-
S5	3	32	169	16	TB3	7	-	-
TB5	1	-	138	-	D8	A	29	D8-A
TB5	2	-	151	-	D8	K	29	D8-K
TB5	3	-	138	-	D9	A	29	D9-A
TB5	4	-	156	-	D9	K	29	D9-K
TB6	1	-	138	-	D10	A	29	D10-A
TB6	2	-	161	-	D10	K	29	D10-K
TB6	3	-	138	-	D11	A	29	D11-A
TB6	4	-	166	-	D11	K	29	D11-K
TB2	4	-	151	16	TB5	2	-	JUMPER
TB2	9	-	156	16	TB5	4	-	JUMPER
TB4	4	-	161	16	TB6	2	-	JUMPER
TB4	9	-	166	16	TB6	4	-	JUMPER
TB3	9	-	171	16	TB1	4	-	JUMPER

Table 3: Bilge Pump Control Assembly A5 and Rear View, Internal Wiring List. (Continued)

FROM	TERM	ITEM #	WIRE #	SIZE	TO	TERM	ITEM #	NOTES
								
<p>NOTES:</p> <ol style="list-style-type: none"> 1. POLARITY OF DIODES, TERMINAL BLOCK DESIGNATIONS, TERMINAL NUMBERS, AND COMPONENT DESIGNATORS AS INDICATED BY SHALL BE PERMANENTLY STAMPED IN INK, LOCATED APPROXIMATELY AS SHOWN. 2. THE BILGE PUMP CONTROL PANEL ASSY IS UNIT A5. 3. MARK ENDS OF INTERNAL WIRES WITH WIRE NUMBERS USING HEAT SHRINK TUBING. COVER TERMINAL LUG BARREL WITH HEAT SHRINK TUBING. 4. RELAY DESIGNATION K1 IS NOT USED IN THIS ASSEMBLY. 5. USE TIE WRAPS AND CABLE TIE MOUNTS TO SECURE WIRE BUNDLES. 6. CONNECT DIODES AS LISTED IN NOTES COLUMN. FOR EXAMPLE D1-A IS THE DIODE WHICH CONNECTS TO DB1-9 D1-K IS THE DIODE CATHODE WHICH CONNECTS TO TB1-10. 								

Table 4: Single Bilge Pump Control A7, Internal Wiring List.

FROM	TERM #	ITEM #	WIRE #	SIZE	TO	TERM	ITEM #	NOTES
K1	30	6	142	16	TB1	3	-	-
K1	87	6	144	16	TB1	2	-	-
K1	86	6	145	16	TB1	1	-	-
K1	85	6	146	16	TB1	8	-	-
K1	85	6	146	16	TB1	4	-	-
S1	1	22	142	16	TB1	3	-	-
S1	2	22	143	16	TB1	5	-	-
S1	3	22	144	16	TB1	2	-	-
D1	A	-	144	16	TB1	2	-	DIODE ANODE
D1	K	-	145	16	TB1	1	-	DIODE CATHODE
-	-	-	0	-	TB1	6	-	TIE POINT (EXTERNAL WIRES)
D2	A	-	138	-	TB1	7	-	DIODE ANODE

Table 4: Single Bilge Pump Control A7, Internal Wiring List. (Continued)

FROM	TERM #	ITEM #	WIRE #	SIZE	TO	TERM	ITEM #	NOTES
D2	K	-	146	16	TB1	8	-	DIODE CATHODE

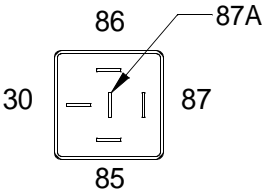
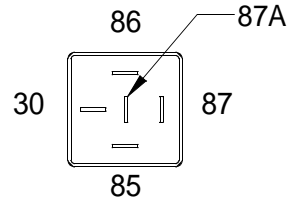
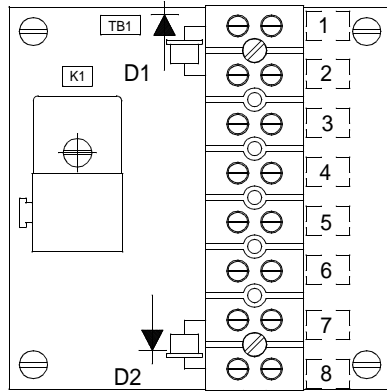

TERMINAL IDENTIFICATION FOR K1

TERMINAL LAYOUT

NOTES:

- 1 POLARITY OF DIODES, TERMINAL NUMBERS AND COMPONENT DESIGNATORS AS INDICATED BY [] SHALL BE PERMANENTLY STAMPED IN INK, LOCATED APPROXIMATELY AS SHOWN.
- 2 THE SINGLE BILGE PUMP CONTROL ASSY' IS UNIT A7 LOCATED IN THE FORWARD COMPARTMENT. UNIT PREFIX IS "1" FOR THE STBD POWER MODULE, "2" FOR THE PORT POWER MODULE. BILGE PUMP ASSY' FOR STBD POWERED MODULE IS "1A7" AND FOR PORT POWOWERED MODULE "2A7".
- 4 LABEL ALL INTERNAL WIRE ENDS WITH WIRE NUMBERS USING HEAT SHRINK TUBING, ITEM 24. COVER TERMINAL LUG BARREL WITH HEAT SHRINK TUBING.

Table 5: Engine Junction Box Assembly A4, Internal Wiring List.

FROM	TERM	ITEM #	WIRE #	SIZE	TO	TERM	ITEM #	NOTES
S1	1	17	116	16	TB1	1	17	-
S1	2	17	0	16	TB1	20	17	-
S1	4	17	117	16	TB1	2	17	-
S1	5	17	118	16	TB1	3	17	-
S1	6	17	119	-	TB1	4	17	-
S1	8	17	120A	-	TB1	5	17	-
R1	-	17	120A	-	TB1	5	17	-

Table 5: Engine Junction Box Assembly A4, Internal Wiring List. (Continued)

FROM	TERM	ITEM #	WIRE #	SIZE	TO	TERM	ITEM #	NOTES
R1	-	17	120	-	TB1	6	17	-
S1	7	17	121	-	TB1	7	17	-
S1	10	17	122	-	TB1	8	17	-
S1	11	17	123	-	TB1	9	17	-
K1	30	6	105	14	TB1	17	17	-
K1	87	6	106	14	TB1	18	17	-
K1	86	6	104	16	TB1	16	17	-
K1	85	6	0	16	TB1	19	17	-
K2	86	6	124	16	TB1	13	17	-
K2	30	6	124	16	TB1	13	17	-
K2	85	6	128	16	TB1	14	17	-
K2	87	6	129	16	TB1	15	17	-
TB1	19	18	0	16	TB1	20	18	JUMPER
TB1	12	18	124	-	TB1	13	18	JUMPER
S2	1	-	105	16	TB1	17	17	-
S2	2	-	106	16	TB1	18	17	-

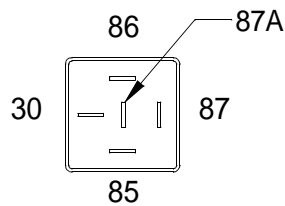

Table 6: Engine Junction Box Assembly A4, External Wires (Reference Only).

FROM	TERM	ITEM #	WIRE #	SIZE	TO	TERM #	ITEM #	NOTES
-	-	-	0	-	TB1	20	-	-
-	-	-	0	-	TB1	19	-	-
-	-	-	103	-	TB1	10	-	-
-	-	-	104	-	TB1	16	-	-
-	-	-	105	-	TB1	17	-	-

Table 6: Engine Junction Box Assembly A4, External Wires (Reference Only). (Continued)

FROM	TERM	ITEM #	WIRE #	SIZE	TO	TERM #	ITEM #	NOTES
-	-	-	106	-	TB1	18	-	-
-	-	-	111	-	TB2	1	-	-
-	-	-	113	-	TB2	2	-	-
-	-	-	115	-	TB2	06	-	-
-	-	-	116	-	TB1	01	-	-
-	-	-	117	-	TB1	02	-	-
-	-	-	118	-	TB1	03	-	-
-	-	-	119	-	TB1	04	-	-
-	-	-	120	-	TB1	06	-	-
-	-	-	121	-	TB1	07	-	-
-	-	-	122	-	TB1	08	-	-
-	-	-	123	-	TB1	09	-	-
-	-	-	124	-	TB1	12	-	-
-	-	-	124	-	TB1	13	-	-
-	-	-	125	-	TB2	07	-	-
-	-	-	126	-	TB2	08	-	-
-	-	-	127	-	TB2	09	-	-
-	-	-	128	-	TB1	14	-	-
-	-	-	129	-	TB1	15	-	-
-	-	-	132	-	TB2	10	-	-
-	-	-	133	-	TB2	3	-	-
-	-	-	134	-	TB2	4	-	-
-	-	-	178	-	TB1	11	-	-
-	-	-	180	-	TB2	5	-	-
-	-	-	SHEILD	-	TB1	8	-	-

Table 7: Power Module Junction Box A3, Internal Wiring List.

TO	TERM	ITEM #	CABLE COND #	WIRE #	CONN	PIN	NOTES
TB1	01	10	1	112	P2	01	-
TB1	02	10	2	113	P2	02	-
TB1	03	10	3	110	P2	03	-
TB1	04	10	4	111	P2	04	-
TB1	05	10	5	114	P2	05	-
TB1	06	10	6	115	P2	06	-
TB1	07	10	7	124	P2	07	-
TB1	08	10	8	104	P2	08	-
TB1	09	10	9	129	P2	09	-
TB1	10	10	10	173	P2	10	-
TB1	11	10	11	174	P2	11	-
TB1	12	10	12	175	P2	12	-
TB1	13	-	13	-	-	-	-
TB1	14	10	14	134	P2	14	-
TB1	15	10	15	135	P2	15	-
TB1	16	10	16	139	P2	16	-
TB1	17	10	17	141	P2	17	-
TB1	18	10	18	143	P2	18	-
TB1	19	10	19	145	P2	19	-
TB1	20	10	20	148	P2	20	-
TB2	01	10	21	150	P2	21	-
TB2	02	10	22	153	P2	22	-
TB2	03	10	23	155	P2	23	-
TB2	04	10	24	158	P2	24	-
TB2	05	10	25	160	P2	25	-
TB2	06	10	26	163	P2	26	-
TB2	07	10	27	165	P2	27	-

Table 7: Power Module Junction Box A3, Internal Wiring List. (Continued)

TO	TERM	ITEM #	CABLE COND #	WIRE #	CONN	PIN	NOTES
TB2	08	10	28	168	P2	28	-
TB2	09	10	29	170	P2	29	-
TB2	10	10	30	181	P2	30	-
TB2	11	10	31	180	P2	31	-
TB2	12	10	32	-	P2	32	SPARE
TB1	13	10	33	0	P2	33	-
TB2	14	10	34	190	P2	34	-
TB2	15	10	35	178	P2	35	-
TB2	16	10	36	187	P2	36	-
TB2	17	10	37	-	P2	37	SPARE
TB2	18	10	6-BK	205	P3	21	-
TB2	19	10	6-WH	206	P3	22	-
TB2	20	-	-	133	-	-	-
TB3	01	10	1-SHD		P3	01	SHIELD
TB3	02	10	1-BK	119	P3	02	-
TB2	03	10	1-WH	121	P3	03	-
TB2	04	10	1-RD	120	P3	04	-
TB2	06	10	2-BK	185	P3	05	-
TB2	07	10	2-WH	186	P3	06	-
TB3	05	10	2-SHD	0	P3	07	SHIELD
TB3	08	10	2-RD		P3	08	SPARE
TB3	10	10	3-BK	182	P3	09	-
TB3	14	10	4-BK	125	P3	10	-
TB3	15	10	4-WH	126	P3	11	-
TB3	16	10	4-RD	127	P3	12	-
TB3	09	10	3-SHD	0	P3	13	SHIELD
TB3	11	10	3-WH	183	P3	14	-

Table 7: Power Module Junction Box A3, Internal Wiring List. (Continued)

TO	TERM	ITEM #	CABLE COND #	WIRE #	CONN	PIN	NOTES
TB3	12	10	6-RD	210	P3	27	-
TB3	13	10	4-SHD	0	P3	16	SHIELD
TB3	17	10	5-BK	132	P3	17	-
TB3	18	10	5-WH	212	P3	18	-
TB3	19	10	5-RD	211	P3	19	-
TB3	20	10	6-SHD	0	P3	20	SHIELD
TB4	01	10	1	146	P4	01	-
TB4	02	10	2	151	P4	02	-
TB4	03	10	3	156	P4	03	-
TB4	04	10	4	161	P4	04	-
TB4	05	10	5	166	P4	05	-
TB4	06	10	6	171	P4	06	-
TB4	07	10	7	138	P4	07	-
TB4	08	10	8	SPARE	P4	08	-
TB4	09	10	9	SPARE	P4	09	-
TB4	10	10	10	220	P4	10	-
TB4	11	10	11	221	P4	11	-
TB4	12	10	12	SPARE	P4	12	-
TB4	13	10	13	SPARE	P4	13	-
TB4	14	10	14	SPARE	P4	14	-

Table 8: Vent Fan Relay Assembly A8, Wire Internal Connections.

FROM	TERM	ITEM #	WIRE #	SIZE	TO	TERM	ITEM #	NOTES
P5	A	21	0	5AWG		LARGE SCREW	8	NO. 4
P5	A	21	136	5AWG	K1	3	4	NO. 4
K1	4	4	0	1AWG	TB1	SMALL SCREW	8	NO. 4

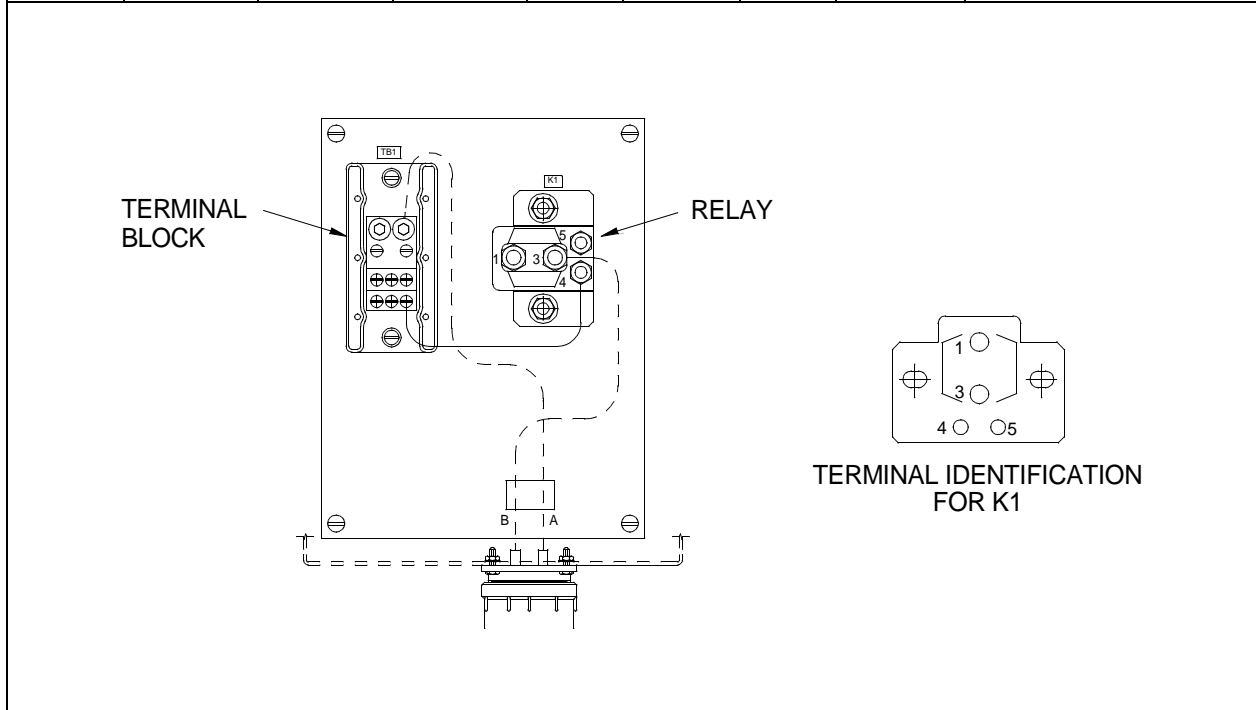

Table 9: Mast Enclosure, Wiring List.

FROM	TERM	ITEM #	WIRE #	SIZE	TO	TERM	ITEM #	NOTES
TB6	A5	-	O	16	TB6	A6	-	JUMPERS
TB6	A6	-	O	16	TB6	A7	-	JUMPERS
TB6	A7	-	O	16	TB6	A8	-	JUMPERS
TB6	A8	-	O	16	TB6	A9	-	JUMPERS
TB6	A9	-	O	16	TB6	A10	-	JUMPERS
TB6	A10	-	O	16	TB6	A11	-	JUMPERS
TB6	B5	-	O	20	DS1	(-)	-	JUMPERS
DS1	(-)	-	O	20	DS11	(-)	-	JUMPERS
DS11	(-)	-	O	20	DS10	(-)	-	JUMPERS

Table 9: Mast Enclosure, Wiring List. (Continued)

FROM	TERM	ITEM #	WIRE #	SIZE	TO	TERM	ITEM #	NOTES
DS10	(-)	-	O	20	DS2-A	(-)	-	JUMPERS
DS2-A	(-)	-	O	20	DS2-B	(-)	-	JUMPERS
DS2-B	(-)	-	O	20	DS9	(-)	-	JUMPERS
DS9	(-)	-	O	20	DS8	(-)	-	JUMPERS
TB6	B6	-	O	20	DS5-1	(-)	-	JUMPERS
DS5-A	(-)	-	O	20	DS5-B	(-)	-	JUMPERS
DS5-B	(-)	-	O	20	DS4-A	(-)	-	JUMPERS
DS4-A	(-)	-	O	20	DS4-B	(-)	-	JUMPERS
DS4-B	(-)	-	O	20	DS12-A	(-)	-	JUMPERS
DS12-A	(-)	-	O	20	DS12-B	(-)	-	JUMPERS
DS12-B	(-)	-	O	20	LS1	(-)	-	JUMPERS
TB6	B2	-	532	10	TB5	B17	-	JUMPERS
TB5	B17	-	532	10	TB5	B6	-	JUMPERS
TB5	B6	-	532	10	TB4	B15	-	JUMPERS
TB4	B15	-	532	10	TB4	B4	-	JUMPERS
TB4	B4	-	532	10	TB3	B14	-	JUMPERS
TB3	B14	-	532	10	TB3	B3	-	JUMPERS
TB3	B3	-	532	10	TB2	B13	-	JUMPERS
TB2	B13	-	532	10	TB2	B2	-	JUMPERS
TB2	B2	-	532	10	TB1	B10	-	JUMPERS
TB1	B10	-	532	10	TB1	A13	-	JUMPERS
TB1	A13	-	532	10	TB2	A5	-	JUMPERS
TB2	A5	-	532	10	TB2	A16	-	JUMPERS
TB2	A16	-	532	10	TB3	A6	-	JUMPERS
TB3	A6	-	532	10	TB3	A17	-	JUMPERS
TB3	A17	-	532	10	TB4	A7	-	JUMPERS
TB4	A7	-	532	10	TB4	A18	-	JUMPERS
TB4	A18	-	532	10	TB5	A9	-	JUMPERS

Table 9: Mast Enclosure, Wiring List. (Continued)

FROM	TERM	ITEM #	WIRE #	SIZE	TO	TERM	ITEM #	NOTES
TB6	A12	-	381	14	F1	1	-	#8
F1	1	-	381	14	F2	1	-	#8
F2	1	-	381	14	F3	1	-	#8
F3	1	-	381	14	F4	1	-	#8
F4	1	-	381	14	F5	1	-	#8
F5	1	-	381	14	F6	1	-	#8
F6	1	-	381	14	F7	1	-	#8
F7	1	-	381	14	F8	1	-	#8
F8	1	-	381	14	F9	1	-	#8
F1	2	-	500	18	S1	2	44	-
F2	2	-	502	18	S2	2	44	-
F3	2	-	505	18	S3	2	44	-
F4	2	-	508	18	S4	2	44	-
F5	2	-	511	18	S5	2	44	-
F6	2	-	517	18	S6	2	44	-
F7	2	-	519	18	S7	2	44	-
F8	2	-	514	18	S8	2	44	-
F9	2	-	521	18	S9	2	44	-
S1	3	44	501A	18	TB1	B9	-	-
K1	2	-	501A	-	TB1	A9	-	#9
K1	4	-	501	-	TB1	A11	-	#9
K1	1	-	531	-	TB1	A16	-	#9
TB1	A16	-	531	-	D1	1	-	10
D1	2	-	532	-	TB1	A10	-	10
K1	3	-	530	-	TB1	A15	-	#9
TB1	B15	-	530	20	DS1	(+)	-	-
S2	3	44	503A	18	TB1	A12	-	-
K2	2	-	503A	-	TB1	B12	-	#9

Table 9: Mast Enclosure, Wiring List. (Continued)

FROM	TERM	ITEM #	WIRE #	SIZE	TO	TERM	ITEM #	NOTES
K2	4	-	503	-	TB1	B14	-	#9
K2	1	-	533	-	TB1	B19	-	#9
TB1	B19	-	533	-	D2	1	-	#10
D2	2	-	532	-	TB1	B13	-	#10
K2	3	-	534	-	TB1	B18	-	#9
TB1	A18	-	534	20	DS2-A	(+)	-	-
S2	1	44	504A	18	TB2	B1	-	-
K3	2	-	504A	-	TB2	A1	-	#9
K3	4	-	504	-	TB2	A3	-	#9
K3	1	-	536	-	TB2	A8	-	#9
TB2	A8	-	536	-	D3	1	-	#10
D3	2	-	532	-	TB2	A2	-	#10
K3	3	-	535	-	TB2	A7	-	#9
TB2	B7	-	535	20	DS2-B	(+)	-	-
S3	3	44	506A	18	TB2	A4	-	-
K4	2	-	506A	-	TB2	B4	-	#9
K4	4	-	506	-	TB2	B6	-	#9
K4	1	-	537	-	TB2	B11	-	#9
TB2	B11	-	537	-	D4	1	-	#10
D4	3	-	532	-	TB2	B5	-	#10
K4	3	-	538	-	TB2	B10	-	#9
TB2	A10	-	538	20	DS3-A	(+)	-	-
S3	1	44	507A	18	TB2	B12	-	-
K5	2	-	507A	-	TB2	A12	0	#9
K5	4	-	507	-	TB2	A14	-	#9
K5	1	-	540	-	TB2	A19	-	#9
TB2	A19	-	540	-	D5	1	-	#10
D5	2	-	532	-	TB2	A13	-	#10

Table 9: Mast Enclosure, Wiring List. (Continued)

FROM	TERM	ITEM #	WIRE #	SIZE	TO	TERM	ITEM #	NOTES
K5	3	-	539	-	TB2	A18	-	#9
TB2	B18	-	539	20	DS3-B	(+)	-	-
S4	3	44	509A	18	TB2	A15	-	-
K6	2	-	509A	-	TB2	B15	-	#9
K6	4	-	509	-	TB2	B17	-	#9
K6	1	-	541	-	TB3	B1	-	#9
TB3	B1	-	541	-	D6	1	-	#10
D6	2	-	532	-	TB2	B16	-	#10
K6	3	-	542	-	TB2	B20	-	#9
TB2	A20	-	542	20	DS4-A	(+)	-	-
S4	1	44	510A	18	TB3	B2	-	-
K7	2	-	510A	-	TB3	A2	-	#9
K7	4	-	510	-	TB3	A4	-	#9
K7	1	-	544	-	TB3	A9	-	#9
TB3	A9	-	544	-	D7	1	-	#10
D7	2	-	532	-	TB3	A3	-	#10
K7	3	-	543	-	TB3	A8	-	#9
TB3	B8	-	543	20	DS4-B	(+)	-	-
S5	3	44	512A	18	TB3	A5	-	-
K8	2	-	512A	-	TB3	B5	-	#9
K8	4	-	512	-	TB3	B7	-	#9
K8	1	-	545	-	TB3	B12	-	#9
TB3	B12	-	545	-	D8	1	-	#10
D8	2	-	532	-	TB3	B6	-	#10
K8	3	-	546	-	TB3	B11	-	#9
TB3	A11	-	546	20	DS5-A	(+)	-	-
S5	1	44	513A	18	TB3	B13	-	-
K9	2	-	513A	-	TB3	A13	-	#9

Table 9: Mast Enclosure, Wiring List. (Continued)

FROM	TERM	ITEM #	WIRE #	SIZE	TO	TERM	ITEM #	NOTES
K9	4	-	513	-	TB3	A15	-	#9
K9	1	-	548	-	TB3	A20	-	#9
TB3	A20	-	548	-	D9	1	-	#10
D9	2	-	532	-	TB3	A14	-	#10
K9	3	-	547	-	TB3	A19	-	#9
TB3	B19	-	547	20	DS5-B	(+)	-	-
S8	3	44	515A	18	TB3	A16	-	-
K10	2	0	515A	-	TB3	B16	-	#9
K10	4	-	515	-	TB3	B18	-	#9
K10	1	-	549	-	TB4	B2	-	#9
TB4	B2	-	549	-	D10	1	-	#10
D10	2	-	532	-	TB3	B17	-	#10
K10	3	-	550	-	TB4	B1	-	#9
TB4	A1	-	550	20	DS12-A	(+)	-	-
S8	1	44	516A	18	TB4	B3	-	-
K11	2	-	516A	-	TB4	A3	-	#9
K11	4	-	516	-	TB4	A5	-	#9
K11	1	-	552	-	TB4	A10	-	#9
TB4	A10	-	552	-	D11	1	-	#10
D11	2	-	532	-	TB4	A4	-	#10
K11	3	-	551	-	TB4	A9	-	#9
TB4	B9	-	551	20	DS12-B	(+)	-	-
S6	3	44	518A	18	TB4	A6	-	-
K12	2	-	518A	-	TB4	A14	-	-
K12	4	-	518	-	TB4	B8	-	#9
K12	1	-	553	-	TB4	B13	-	#9
TB4	B13	-	553	-	D12	1	-	#10
D12	2	-	532	-	TB4	B7	-	#10

Table 9: Mast Enclosure, Wiring List. (Continued)

FROM	TERM	ITEM #	WIRE #	SIZE	TO	TERM	ITEM #	NOTES
K12	3	-	554	-	TB4	B12	-	#9
TB4	A12	-	554	20	DS6	(+)	-	-
K13	2	-	518A	-	TB4	A14	-	#9
K13	4	-	518B	-	TB4	A16	-	#9
K13	1	-	556	-	TB5	A1	-	#9
TB5	A1	-	556	-	D13	1	-	#10
D13	2	-	532	-	TB4	A15	-	#10
K13	3	-	555	-	TB4	A20	0	#9
TB4	B20	-	555	20	DS7	(+)	-	-
S7	3	44	520A	18	TB4	A17	-	-
TB4	A17	-	520A	18	TB5	A5	-	-
K14	2	-	520A	-	TB4	B17	-	#9
K14	4	-	520	-	TB4	B19	-	#9
K14	1	-	557	-	TB5	B3	-	#9
TB5	B3	-	557	-	D14	1	-	#10
D14	2	-	532	-	TB4	B18	-	#10
K14	3	-	558	-	TB5	B2	-	#9
TB5	A2	-	558	20	DS8	(+)	-	-
K15	2	-	520A	-	TB5	A5	-	#9
K15	4	-	520B	-	TB5	A7	-	#9
K15	1	-	560	-	TB5	A12	-	#9
TB5	A12	-	560	-	D15	1	-	#10
D15	2	-	532	-	TB5	A6	-	#10
K15	3	-	559	-	TB5	A11	-	#9
TB6	B11	-	559	20	DS9	(+)	-	-
S9	3	44	522A	18	TB5	A8	-	-
TB5	A8	-	522A	18	TB5	A16	-	-
K16	2	-	522A	-	TB5	B8	-	#9

Table 9: Mast Enclosure, Wiring List. (Continued)

FROM	TERM	ITEM #	WIRE #	SIZE	TO	TERM	ITEM #	NOTES
K16	4	-	522	-	TB5	B10	-	#9
K16	1	-	561	-	TB5	B15	-	#9
TB5	B15	-	561	-	D16	1	-	#10
D16	2	-	532	-	TB5	B9	-	#10
K16	3	-	562	-	TB5	B14	-	#9
TB5	A14	-	562	20	DS10	(+)	-	-
K17	2	-	522A	-	TB5	A16	-	#9
K17	4	-	522B	-	TB5	A18	-	#9
K17	1	-	564	-	TB6	A1	-	#9
TB6	A1	-	564	-	D17	1	-	#10
D17	2	-	532	-	TB5	A17	-	#10
K17	3	-	563	-	TB5	A20	-	#9
TB5	B20	-	563	20	DS11	(+)	-	-
TB6	A2	-	532	20	S10	2	-	-
S10	1	-	565	20	LS1	(+)	-	-

Table 10: Navigation Lights Terminal Box Wiring List and Rear View.

FROM	TERM	ITEM #	COLOR	WIRE #	SIZE	TO	TERM	NOTES
P1	1	5	BLK	501	18	TB1	1	-
P1	2	5	WHT	503	18	TB	2	-
P1	3	5	RED	504	18	TB1	3	-
P1	4	5	GRN	506	18	TB1	4	-
P1	5	5	ORG	507	18	TB1	5	-
P1	6	5	BLU	509	18	TB1	6	-
P1	7	5	WHT/BLK	510	18	TB1	7	-
P1	8	5	RED/BLK	512	18	TB1	8	-
P1	9	5	GRN/BLK	513	18	TB1	9	-
P1	10	5	OR/BLK	518	18	TB1	10	-

Table 10: Navigation Lights Terminal Box Wiring List and Rear View. (Continued)

FROM	TERM	ITEM #	COLOR	WIRE #	SIZE	TO	TERM	NOTES
P1	11	5	BLU/BLK	518B	18	TB2	1	-
P1	12	5	BLK/WHT	520	18	TB2	2	-
P1	13	5	RED/WHT	520B	18	TB2	3	-
P1	14	5	GRN/WHT	522	18	TB2	4	-
P1	15	5	BLU/WHT	522B	18	TB2	5	-
P1	16	5	BLK/RED	-	-	-	-	SPARE
P1	17	5	WHT/RED	-	-	-	-	SPARE
P1	18	5	OR/RED	0	18	TB3	1	-
P1	19	5	BLU/RED	0	18	TB3	3	-
P1	20	5	RED/GRN	0	18	TB3	5	-
P1	21	5	OR/GRN	0	18	TB3	7	-
P1	22	5	BLK/ WHT/RED	-	-	-	-	SPARE
P1	23	5	WHT/ BLK/RED	-	-	-	-	SPARE
P1	24	5	RED/BLK/ WHT	-	-	-	-	SPARE
TB3	1	29	-	-	-	TB3	2	JUMPER
TB3	2	29	-	-	-	TB3	3	JUMPER
TB3	3	29	-	-	-	TB3	4	JUMPER
TB3	4	29	-	-	-	TB3	5	JUMPER
TB3	5	29	-	-	-	TB3	6	JUMPER
TB3	6	29	-	-	-	TB3	7	JUMPER
TB3	7	29	-	-	-	TB3	8	JUMPER
TB3	8	29	-	-	-	TB3	9	JUMPER
TB3	9	29	-	-	-	TB3	10	JUMPER
J2	A	3	WHT	509	16	TB1	6	1
J2	B	3	WHT	0	16	TB3	8	-
J2	C	3	WHT	510	16	TB1	8	-

Table 10: Navigation Lights Terminal Box Wiring List and Rear View. (Continued)

FROM	TERM	ITEM #	COLOR	WIRE #	SIZE	TO	TERM	NOTES
J3	A	3	WHT	512	16	TB1	8	-
J3	B	3	WHT	0	16	TB3	7	-
J3	C	3	WHT	513	16	TB1	9	-
-	-	-	-	-	-	-	-	-
-	-	-	-	-	-	-	-	-

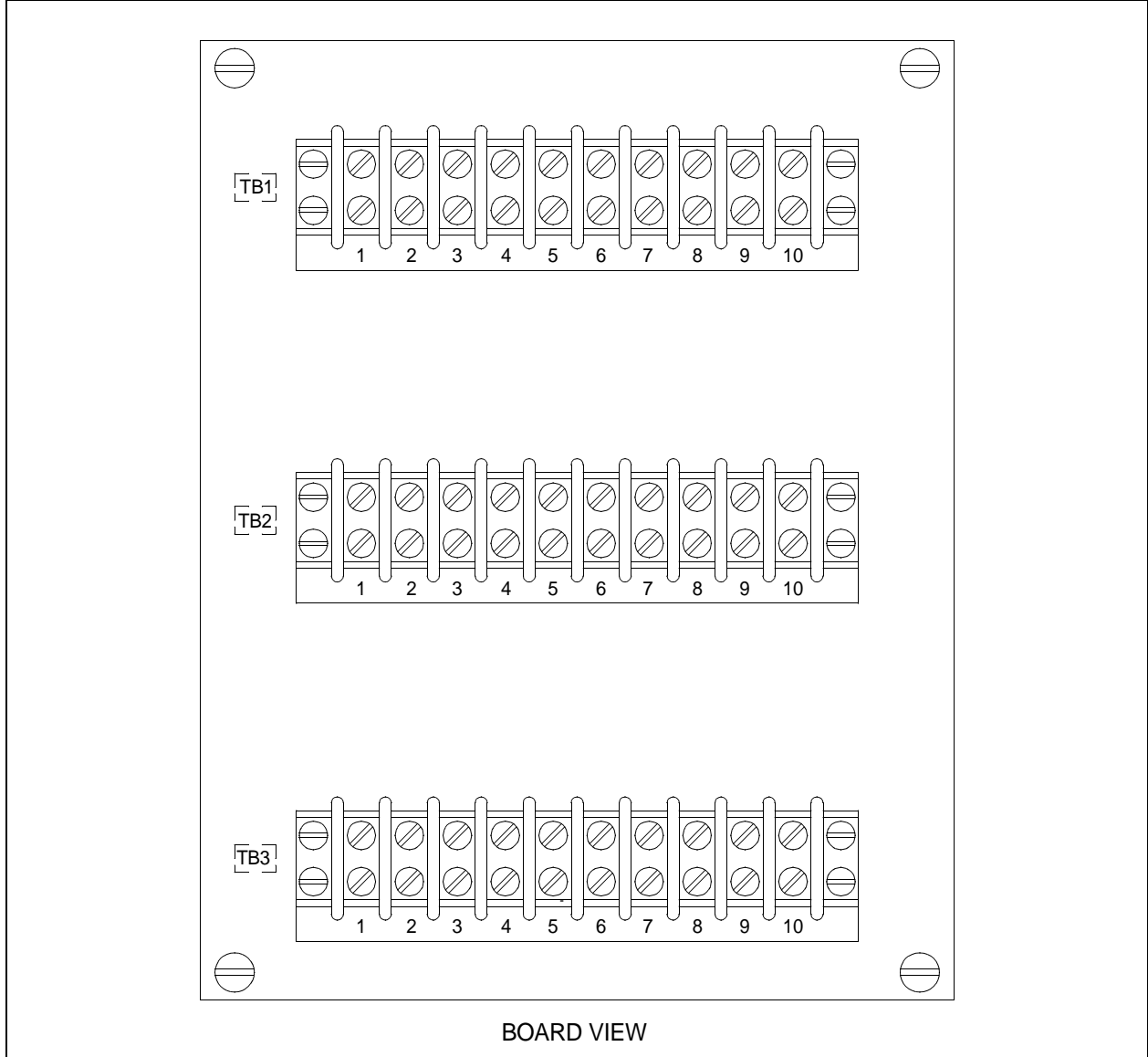

Table 11: Middle Control Panel, Wiring Diagram and Lists.

FROM	TERM	ITEM #	WIRE #	SIZE	TO	TERM	ITEM #	NOTES
TAP	0	-	0	16	A4TB10	4	-	NOTE 1
M1	(-)	35	0	16	(0)	TAP	34	NOTE 6
M1	2	35	0	16	(0)	TAP	34	NOTE 6
M10	(-)	35	0	16	(0)	TAP	34	NOTE 6
M10	2	35	0	16	(0)	TAP	34	NOTE 6
-	-	-	-	-	-	-	-	-
M2	2	35	0	16	(0)	TAP	34	NOTE 6
M3	(-)	35	0	16	(0)	TAP	34	NOTE 6
M3		35	0	16	(0)	TAP	34	NOTE 6
M4	(-)	35	0	16	(0)	TAP	34	NOTE 6
M4	2	35	0	16	(0)	TAP	34	NOTE 6
M5	(-)	35	0	16	(0)	TAP	34	NOTE 6
M5	2	35	0	16	(0)	TAP	34	NOTE 6
M6	2	35	0	16	(0)	TAP	34	NOTE 6
M6	(-)	35	0	16	(0)	TAP	34	NOTE 6
M7	2	35	0	16	(0)	TAP	34	NOTE 6
M7	(-)	35	0	16	(0)	TAP	34	NOTE 6
-	-	-	-	-	-	-	-	-
M8	2	35	0	16	(0)	TAP	34	NOTE 6
M9	(-)	35	0	16	(0)	TAP	34	NOTE 6
M9	2	35	0	16	(0)	TAP	34	NOTE 6
-	-	-	-	-	-	-	-	-
-	-	-	-	-	-	-	-	-
-	-	-	-	-	-	-	-	-
-	-	-	-	-	-	-	-	-
-	-	-	-	-	-	-	-	-
M2	/	65	301	10	A45B5	16	66	NOTE 1

Table 11: Middle Control Panel, Wiring Diagram and Lists. (Continued)

FROM	TERM	ITEM #	WIRE #	SIZE	TO	TERM	ITEM #	NOTES
M2	+	65	301A	10	A4TB5	18	66	NOTE 1
M8	/	65	302	10	A45B9	7	66	NOTE 1
M8	+	65	302A	10	A4TB9	9	66	NOTE 1
S8	1	-	303	16	(303)	TAP	34	NOTE 6
S8	1	-	303	14	A4TB5	14	-	NOTE 1
S5	11	-	303	16	(303)	TAP	34	NOTE 6
S5	1	-	303	16	(303)	TAP	34	NOTE 6
S4	1	-	303	16	(303)	TAP	34	NOTE 6
S14	11	-	303	16	(303)	TAP	34	NOTE 6
S14	1	-	303	16	S4	1	34	NOTE 6
S14	10	-	303e	16	S14	4	34	NOTE 6
S5	10	-	303D	16	S5	4	34	NOTE 6
S4	2	-	304	14	A4TB1	6	34	NOTE 6
S8	2	-	305	16	A4TB3	6	-	NOTE 1
S3	2	-	306	16	A4TB1	7	-	NOTE 1
S1	2	55	308	16	A4TB1	10	-	NOTE 1
S15	1	55	308	16	S1	2	55	-
S1	3	55	309	16	A4TB1	11	-	NOTE 1
S3	1	-	309	16	S1	3	55	-
S2	1	-	310	16	A4TB1	8	-	NOTE 1
S2	2	-	312	16	A4TB1	9	-	NOTE 1
M1	S	35	313	16	A4TB1	2	-	NOTE 1
M4	S	35	314	16	A4TB1	3	-	NOTE 1
M3	S	35	315	16	A4TB1	1	-	NOTE 1
S15	2	55	316	16	(316)	TAP	34	NOTE 5,6
M1	R1/+	35	316	16	(316)	TAP	34	NOTE 5,6
M3	R2/+	35	316	16	(316)	TAP	34	NOTE 5,6
M4	R3/+	35	316	16	(316)	TAP	34	NOTE 5,6

Table 11: Middle Control Panel, Wiring Diagram and Lists. (Continued)

FROM	TERM	ITEM #	WIRE #	SIZE	TO	TERM	ITEM #	NOTES
M5	R4/+	35	316	16	S15	2	-	NOTE 1,5,6
S15	2	55	316	16	A4TB1	5	55	NOTE 1
M5	S	35	317	16	A4TB1	4	-	NOTE 1
S6	2	-	320	16	A4TB3	10	-	NOTE 1
S13	1	55	320	16	S6	2	55	-
S7	1	-	321	16	A4TB3	9	-	NOTE 1
S13	2	55	324	16	(324)	TAP	34	NOTE 6
M10	R8/+	35	324	16	(324)	TAP	34	NOTE 5,6
M6	R5/+	35	324	16	(324)	TAP	34	NOTE 5,6
M7	R6/+	35	324	16	(324)	TAP	34	NOTE 5,6
M9	R7/+	35	324	16	(324)	TAP	34	NOTE 5,6
S13	2	55	324	16	A4TB3	5	55	NOTE 1
M7	S	35	325	16	A4TB3	2	-	NOTE 1
M10	S	35	326	16	A4TB3	3	-	NOTE 1
M9	S	35	327	16	A4TB3	4	-	NOTE 1
-	-	-	-	-	-	-	-	-
-	-	-	-	-	-	-	-	-
S5	6	55	365A	16	S5	3	55	-
S5	3	55	365A	16	A4TB3	12	-	NOTE 1
S14	3	-	365	16	S14	6	34	NOTE 6
S14	6	-	365	16	A4TB1	12	-	NOTE 1
S9	2	-	366	16	A4TB1	7	-	NOTE 1
S6	3	-	367	16	A4TB3	11	-	NOTE 1
S9	1	-	367	16	S6	3	55	-
-	-	-	-	-	-	-	-	-
S5	5	-	368	16	A4TB10	10	-	NOTE 1
S14	5	-	368A	16	A4TB10	9	-	NOTE 1
DS1	1	55	369	16	S5	2	55	NOTE 4

Table 11: Middle Control Panel, Wiring Diagram and Lists. (Continued)

FROM	TERM	ITEM #	WIRE #	SIZE	TO	TERM	ITEM #	NOTES
DS2	1	-	369A	16	S14	2	34	NOTE 6
TAP	375	-	375	16	A4TB5	19	-	NOTE 1
M1	1	35	375	16	(375)	TAP	34	NOTE 6
M10	1	35	375	16	(375)	TAP	34	NOTE 6
M2	1	35	375	16	(375)	TAP	34	NOTE 6
M3	1	35	375	16	(375)	TAP	34	NOTE 6
-	-	-	-	-	-	-	-	-
-	-	-	-	-	-	-	-	-
-	-	-	-	-	-	-	-	-
-	-	-	-	-	-	-	-	-
-	-	-	-	-	-	-	-	-
M4	1	35	375	16	(375)	TAP	34	NOTE 6
M5	1	35	375	16	(375)	TAP	34	NOTE 6
M6	1	35	375	16	(375)	TAP	34	NOTE 6
M7	1	35	375	16	(375)	TAP	34	NOTE 6
M8	1	35	375	16	(375)	TAP	34	NOTE 6
M9	1	35	375	16	(375)	TAP	34	NOTE 6
S11	2	-	382	14	A3CB2	2	-	NOTE 1
S11	3	-	383	14	A4TB5	5	-	NOTE 1
S10	1	-	384	16	A4TB5	2	-	NOTE 1
S10	2	-	385	16	A4TB5	4	-	NOTE 1
S12	2	55	387	16	A3CB4	2	-	NOTE 1
S12	3	55	388	16	A4TB5	6	-	NOTE 1
-	-	-	-	-	-	-	-	-
P12	TB-3	42	409	16	A4TB6	1	-	-
P12	TB-5	42	410	16	A4TB6	2	-	-
P12	TB-1	42	411	16	A4TB6	4	-	-
P12	TB-2	2	412	16	A4TB6	5	-	-

Table 11: Middle Control Panel, Wiring Diagram and Lists. (Continued)

FROM	TERM	ITEM #	WIRE #	SIZE	TO	TERM	ITEM #	NOTES
-	-	-	SHLD	-	A4TB6	3	-	-
P12	(+)	42	407	16	A4TB7	3	-	-
P12	(-)	42	408	16	A45B7	6	-	-
-	-	-	SHLD	-	A4TB7	5	-	-
P12	LT-1	42	375	16	(375)	TAP	34	NOTE 6
P12	LT-2	42	0	16	(0)	TAP	34	NOTE 6
-	-	-	-	-	-	-	-	-
P11	TB-3	42	423	16	A4TB8	1	-	-
P11	TB-5	42	424	16	A4TB8	2	-	-
P11	TB-1	42	427	16	A4TB8	4	-	-
P11	TB-2	42	428	16	A4TB8	5	-	-
-	-	-	SHLD	-	A4TB10	3	-	-
P11	(+)	42	422	16	A4TB9	3	-	-
P11	(-)	42	434	16	A4TB9	6	-	-
-	-	-	SHLD	-	A4TB9	5	-	-
P11	LT-1	42	375	16	(375)	TAP	34	NOTE 6
P11	LT-2	42	0	16	(0)	TAP	34	NOTE 6
-	-	-	-	-	-	-	-	-
-	-	-	-	-	-	-	-	-
-	-	-	-	-	-	-	-	-
-	-	-	-	-	-	-	-	-
-	-	-	-	-	-	-	-	-
-	-	-	-	-	-	-	-	-
DS1	2	36	461	16	A4TB10	6		NOTE 1
DS2	2	-	461A	16	A4TB10	7		NOTE 1

Table 12: Lower Control Panel, Wiring Diagram and List.

FROM	TERM	ITEM #	WIRE #	SIZE	TO	TERM	ITEM #	NOTES
S2	1	47	0	16	S2	11	47	-
S2	11	47	-	16	DS9	2	47	-
R1	BLACK	52	0	16	(0)	TAP	50	NOTE 6
D17	2	SOLDER	0	14	A4TB10	3	47	-
DS8	2	47	0	16	D17	2	47	-
DS8	2	47	0	16	DS9	2	47	-
S2	3	47	138	16	S2	6	47	-
S2	6	47	138	16	A4TB5	10	47	-
S13	1	44	303	16	(303)	TAP	50	NOTE 6
S18	1	44	303	16	(303)	TAP	50	NOTE 6
S1	1	44	303	16	(303)	TAP	50	NOTE 6
S20	1	44	303	16	(303)	TAP	50	NOTE 6
S1	11	47	303	16	A4TB5	13	47	NOTE 6
S17	1	44	303	16	(303)	TAP	50	NOTE 6
S12	1	44	303	16	(303)	TAP	50	NOTE 6
S15	1	44	303	16	(303)	TAP	50	NOTE 6
S16	1	44	303	16	(303)	TAP	50	NOTE 6
S19	1	44	303	16	(303)	TAP	50	NOTE 6
S3	1	44	303	16	(303)	TAP	50	NOTE 6
S14	1	44	303	16	(303)	TAP	50	NOTE 6
S11	1	44	303	16	(303)	TAP	50	NOTE 6
S10	1	44	303	16	(303)	TAP	50	NOTE 6
S9	1	44	303	16	(303)	TAP	50	NOTE 6
DS10	1	89	303	16	S1	1	47	-
DS10	1	89	303	16	DS11	1	89	-
DS11	1	89	303	20	DS20	(+)	SOLDER	-
DS20	(+)	SOLDER	303	20	DS19	(+)	SOLDER	-
DS19	(+)	SOLDER	303	20	DS17	(+)	SOLDER	-

Table 12: Lower Control Panel, Wiring Diagram and List. (Continued)

FROM	TERM	ITEM #	WIRE #	SIZE	TO	TERM	ITEM #	NOTES
DS17	(+)	SOLDER	303	20	DS15	(+)	SOLDER	-
DS15	(+)	SOLDER	303	20	DS16	(+)	SOLDER	-
DS16	(+)	SOLDER	303	20	DS18	(+)	SOLDER	-
DS18	(+)	SOLDER	303	20	DS26	(+)	SOLDER	-
DS26	(+)	SOLDER	303	20	DS25	(+)	SOLDER	-
DS25	(+)	SOLDER	303	20	DS23	(+)	SOLDER	-
DS23	(+)	SOLDER	303	20	DS21	(+)	SOLDER	-
DS21	(+)	SOLDER	303	20	DS22	(+)	SOLDER	-
DS22	(+)	SOLDER	303	20	DS24	(+)	SOLDER	-
S1	11	44	303	16	S1	1	47	-
S3	11	44	303	16	S3	1	47	-
S3	10	44	303A	16	S3	4	47	-
S1	10	44	303B	16	S1	4	47	-
S2	10	44	303C	16	S2	4	47	-
DS4	1	47	311	16	A4TB2	16	47	NOTE 1
DS5	1	47	323	16	ARTB4	16	47	NOTE 1
R1	WHITE	52	329	16	D16	2	SOLDER	-
D16	2	52	329	16	D15	2	SOLDER	JUMPER
D15	2	52	329	16	D14	2	SOLDER	JUMPER
D14	2	52	329	16	D13	2	SOLDER	JUMPER
D13	2	52	329	16	D12	2	SOLDER	JUMPER
D12	2	52	329	16	D11	2	SOLDER	JUMPER
D11	2	52	329	16	D10	2	SOLDER	JUMPER
D10	2	52	329	16	D9	2	SOLDER	JUMPER
D9	2	52	329	16	D8	2	SOLDER	JUMPER
D8	2	52	329	16	D7	2	SOLDER	JUMPER
D7	2	52	329	16	D6	2	SOLDER	JUMPER
D6	2	52	329	16	D5	2	SOLDER	JUMPER

Table 12: Lower Control Panel, Wiring Diagram and List. (Continued)

FROM	TERM	ITEM #	WIRE #	SIZE	TO	TERM	ITEM #	NOTES
D5	2	52	329	16	D4	2	SOLDER	JUMPER
D4	2	52	329	16	D3	2	SOLDER	JUMPER
D3	2	52	329	16	D2	2	SOLDER	JUMPER
D2	2	52	329	16	D1	2	SOLDER	JUMPER
S9	2	44	330	16	A4TB2	1	47	NOTE 1
S9	A	44	331	16	A4TB2	2	47	NOTE 1
S10	2	44	332	16	A4TB2	3	47	NOTE 1
S10	A	44	333	16	A4TB2	4	47	NOTE 1
S11	2	44	334	16	A4TB2	5	47	NOTE 1
S11	A	44	335	16	A4TB2	6	47	NOTE 1
S12	2	44	336	16	A4TB2	7	47	NOTE 1
S12	A	44	337	16	A4TB2	8	47	NOTE 1
S13	2	44	338	16	A4TB2	9	47	NOTE 1
S13	A	44	339	16	A4TB2	10	47	NOTE 1
S14	2	44	340	16	A4TB2	11	47	NOTE 1
S14	A	44	341	16	A4TB2	12	47	NOTE 1
S15	2	44	342	16	A4TB2	1	47	NOTE 1
S15	A	44	343	16	A4TB2	2	47	NOTE 1
S16	2	44	344	16	A4TB2	3	47	NOTE 1
S16	A	44	345	16	A4TB2	4	47	NOTE 1
S17	2	44	346	16	A4TB2	5	47	NOTE 1
S17	A	44	347	16	A4TB2	6	47	NOTE 1
S18	2	44	348	16	A4TB2	7	47	NOTE 1
S18	A	44	349	16	A4TB2	8	47	NOTE 1
S19	2	44	350	16	A4TB2	9	47	NOTE 1
S19	A	44	351	16	A4TB2	10	47	NOTE 1
S20	2	44	352	16	A4TB2	11	47	NOTE 1
S20	A	44	353	16	A4TB2	12	47	NOTE 1

Table 12: Lower Control Panel, Wiring Diagram and List. (Continued)

FROM	TERM	ITEM #	WIRE #	SIZE	TO	TERM	ITEM #	NOTES
DS2	2	47	354	16	LS1	(+)	47	-
LS1	(+)	476	354	16	A4TB4	18	47	-
-	-	-	-	-	-	-	-	-
S2	5	47	355	16	LS1	(-)	47	-
DS2	1	47	356	16	S2	2	47	NOTE 4
S3	3	47	357	16	A4TB4	17	47	NOTE 1
S3	6	47	357	16	S3	3	47	-
S3	5	47	358	16	A4TB5	9	47	NOTE 1
DS3	1	47	360	16	S3	2	47	NOTE 4
DS3	2	52	360A	16	A4TB10	1	47	NOTE 1
S1	6	47	361	16	S1	3	47	-
S1	3	47	361	16	A4TB2	17	47	NOTE 1
S1	5	47	3621	16	A4TB5	11	47	NOTE 1
DS1	1	37	363	16	S1	2	47	NOTE 4
S21	2	47	370	16	A4TB1	13	47	NOTE 1
S21	3	47	371	16	A4TB1	14	47	NOTE 1
S21	3	47	371	16	DS6	1	47	NOTE 4
S22	2	47	372	16	A4TB3	13	47	NOTE 1
S22	3	47	373	16	A4TB3	14	47	NOTE 1
S22	3	47	272	16	DS7	1	47	NOTE 4
R1	RED	52	374	16	A3CB9	2	45	NOTE 1
R1	BLUE	52	375	16	A4TB5	19	47	NOTE 1
S4	5	47	389	16	S4	2	47	-
S4	2	47	389	16	A3CB5	2	45	NOTE 1
S25	2	47	389	16	S4	5	47	-
S4	1	47	390	16	S4	3	47	-
S4	3	47	390	16	A4TB5	7	47	NOTE 1
S4	6	47	391	A6	A4TB5	8	47	NOTE 1

Table 12: Lower Control Panel, Wiring Diagram and List. (Continued)

FROM	TERM	ITEM #	WIRE #	SIZE	TO	TERM	ITEM #	NOTES
R2	L	47	395	A6	A4TB1	15	47	NOTE 1
R2	R	47	396	A6	A4TB1	A6	47	NOTE 1
R2	C	47	397	16	A4TB1	17	47	NOTE 1, WIPER
R3	L	47	398	16	A4TB3	A5	47	NOTE 1
R3	R	47	399	16	A4TB3	A6	47	NOTE 1
R3	C	47	400	16	A4TB3	17	47	NOTE 1, WIPER
S5	2	47	401	16	S5	5	47	-
S5	2	47	401	16	A4TB2	14	47	NOTE 1
S5	3	47	402	16	A4TB2	15	47	NOTE 1
S6	1	47	403	16	A4TB2	14	47	NOTE 1
S6	2	47	404	16	S6	5	47	-
S6	2	47	404	16	A4TB4	14	47	NOTE 1
S6	3	47	405	16	A4TB4	15	47	NOTE 1
S6	1	47	406	16	A4TB4	13	47	NOTE 1
DS10	2	89	416	16	A4TB7	8	47	-
S23	23	47	417	16	A4TB7	8	47	-
DS8	1	47	418	16	4TB7	1	47	NOTE 1,10
S23	14	47	419	16	A4TB7	2	47	NOTE 1,10
S23	3	47	420	16	A4TB6	7	47	NOTE 1,10
S23	3	47	420	16	S23	24	47	-
S5	6	47	425	16	A4TB2	19	47	NOTE 1
S5	4	47	425	16	S5	6	47	JUMPER
S6	6	47	426	16	A4TB2	20	47	NOTE 1
S6	4	47	426	16	S6	6	47	JUMPER
DS11	2	89	433	16	A4TB9	8	47	-
S24	23	47	435	16	A4TB9	1	47	NOTE 1,10
DS9	1	47	436	16	A4TB9	4	47	-
S24	14	47	437	16	A4TB9	2	47	NOTE 1,10

Table 12: Lower Control Panel, Wiring Diagram and List. (Continued)

FROM	TERM	ITEM #	WIRE #	SIZE	TO	TERM	ITEM #	NOTES
S24	13	47	438	16	A4TB8	8	47	NOTE 1,10
S24	13	47	438	16	S24	24	47	-
S25	3	47	442	16	A4TB5	15	47	NOTE 1
DS1	2	51	460	16	D17	1	SOLDER	-
DS7	2	51	462	16	D16	1	SOLDER	-
DS6	2	51	463	16	D15	1	SOLDER	-
S20	B	52	464	16	D14	1	SOLDER	-
S19	B	52	465	16	D13	1	SOLDER	-
S18	B	52	466	16	D12	1	SOLDER	-
S17	B	52	467	16	D11	1	SOLDER	-
S16	B	52	468	16	D10	1	SOLDER	-
S15	B	52	469	16	D9	1	SOLDER	-
S14	B	52	470	16	D8	1	SOLDER	-
S13	B	52	471	16	D7	1	SOLDER	-
S12	B	52	472	16	D6	1	SOLDER	-
S11	B	52	473	16	D5	1	SOLDER	-
S10	B	52	474	16	D4	1	SOLDER	-
S9	B	52	475	16	D3	1	SOLDER	-
DS5	2	52	476	16	D2	1	SOLDER	-
DS4	2	52	477	16	D1	1	SOLDER	-
DS15	(-)	SOLDER	500	20	A4TB1	19	97	-
DS16	(-)	SOLDER	501	20	A4TB1	20	97	-
DS17	(-)	SOLDER	502	20	A4TB3	19	97	-
DS18	(-)	SOLDER	503	20	A4TB3	20	97	-
DS19	(-)	SOLDER	504	20	A4TB4	19	97	-
DS20	(-)	SOLDER	505	20	A4TB4	20	97	-
DS21	(-)	SOLDER	506	20	A4TB6	6	97	-
DS22	(-)	SOLDER	507	20	A4TB7	7	97	-

Table 12: Lower Control Panel, Wiring Diagram and List. (Continued)

FROM	TERM	ITEM #	WIRE #	SIZE	TO	TERM	ITEM #	NOTES
DS23	(-)	SOLDER	508	20	A4TB7	9	97	-
DS24	(-)	SOLDER	509	20	A4TB7	10	97	-
DS25	(-)	SOLDER	510	20	A4TB8	6	97	-
DS26	(-)	SOLDER	511	20	A4TB8	7	97	-

Table 13: Terminal Strip A4 Assembly, Wiring List.

CONNECTION	TERM	WIRE #	FROM	TERM	NOTES
TB01	1	315	A1M3	S	-
TB01	1	315	A6J3	12	-
TB01	2	313	A1M3	S	-
TB01	2	313	A6J3	10	-
TB01	3	314	A1M4	S	-
TB01	3	314	A6J3	11	-
TB01	4	317	A1M5	S	-
TB01	4	317	AA6J3	S	-
TB01	5	316	A1S15	2	-
TB01	5	316	A6J2	7	-
TB01	6	304	A1S4	2	-
TB01	6	304	A6J2	8	-
TB01	7	306	A1S3	2	-
TB01	7	306	A6J2	6	-
TB01	8	310	A1S2	1	-
TB01	8	310	K2	87A	-
TB01	9	312	A1S2	2	-
TB01	9	312	A6J2	2	-
TB01	10	308	A1S1	2	-
TB01	10	308	A3J2	3	-
TB01	11	309	A1S1	3	-

Table 13: Terminal Strip A4 Assembly, Wiring List. (Continued)

CONNECTION	TERM	WIRE #	FROM	TERM	NOTES
TB01	11	309	A6H2	4	-
TB01	11	309	K2	30	-
TB01	12	365	A6J2	9	-
TB01	12	365	A1S14	6	-
TB01	13	370	A2S21	2	-
TB01	13	370	A6J2	14	-
TB01	14	371	A2S21	3	-
TB01	14	371	A6J2	15	-
TB01	15	395	A2R2	L	-
TB01	15	385	A6J3	2	-
TB01	16	396	A2R2	R	-
TB01	16	396	A6J3	3	-
TB01	17	397	A2R2	C	-
TB01	17	397	A3TB2	5	-
TB01	17	397	A6J3	4	-
TB01	18	0	A2R2		SHIELD
TB01	18	0	TB11	-	-
TB01	19	500	A2DS15	(-)	-
TB01	19	500	A6J4	1	-
TB01	20	501	A2DS16	(-)	-
TB01	20	501	A6J4	2	-
TB02	1	330	A2S9	2	-
TB02	1	330	A6J2	19	-
TB02	2	331	A2S9	A	-
TB02	2	331	A6J2	18	-
TB02	3	332	A2S10	2	-
TB02	3	332	A6J2	21	-
TB02	4	333	A2S10	A	-

Table 13: Terminal Strip A4 Assembly, Wiring List. (Continued)

CONNECTION	TERM	WIRE #	FROM	TERM	NOTES
TB02	4	333	A6J2	20	-
TB02	5	334	A2S11	2	-
TB02	5	334	A6J2	23	-
TB02	6	335	A2S11	A	-
TB02	6	335	A6J2	22	-
TB02	7	336	A2S12	2	-
TB02	7	336	A6J2	25	-
TB02	8	337	A2S12	A	-
TB02	8	337	A6J2	24	-
TB02	9	338	A2S13	2	-
TB02	9	338	A6J2	27	-
TB02	10	339	A2S13	A	-
TB02	10	339	A6J2	26	-
TB02	11	340	A2S14	2	-
TB02	11	340	A6J2	29	-
TB02	12	341	A2S14	A	-
TB02	12	341	A6J2	28	-
TB02	13	403	A2S5	1	-
TB02	13	403	A6J2	12	-
TB02	14	401	A2S5	2	-
TB02	14	401	A6J2	10	-
TB02	15	402	A2S5	3	-
TB02	15	402	A6J2	11	-
TB02	16	311	A2DS4	1	-
TB02	16	311	K2	87	-
TB02	17	361	A2S1	3	-
TB02	17	361	A6J2	17	-
TB02	18	354	A6J2	16	-

Table 13: Terminal Strip A4 Assembly, Wiring List. (Continued)

CONNECTION	TERM	WIRE #	FROM	TERM	NOTES
TB02	18	354	TB04	18	14 GA. WIRE
-	-		-	-	-
TB02	19	425	A2S5	6	-
TB02	19	425	K2	85	-
TB02	20	426	A2S6	85	-
TB02	1	426	A1M9	6	-
TB03	1	327	A5J3	12	-
TB03	2	325	A1M7	S	-
TB03	2	325	A5J3	10	-
TB03	3	326	A1M10	S	-
TB03	3	326	A5J3	11	-
TB03	4	328	A1M6	S	-
TB03	4	328	A5J3	17	-
TB03	5	324	A1S13	12	-
TB03	5	324	A5J2	7	-
TB03	6	305	A1S8	2	-
TB03	6	305	A5J2	8	-
TB03	7	366	A1S9	2	-
TB03	7	366	A5J2	6	-
TB03	8	321	A1S7	1	-
TB03	8	321	K3	87A	-
TB03	9	322	A1S7	2	-
TB03	9	322	A5J2	2	-
TB03	10	320	A1S6	2	-
TB03	10	320	A5J2	3	-
TB03	11	367	A1S6	3	-
TB03	11	367	A5J2	4	-
TB03	11	367	K3	30	-

Table 13: Terminal Strip A4 Assembly, Wiring List. (Continued)

CONNECTION	TERM	WIRE #	FROM	TERM	NOTES
TB03	12	365A	A1S5	3	-
TB03	12	365A	A5J2	9	-
TB03	13	372	A2S22	2	-
TB03	13	372	A5J2	14	-
TB03	14	373	A2S22	3	-
TB03	14	373	A5J2	15	-
TB03	15	398	A2R3	L	-
TB03	15	398	A5J3	2	-
TB03	16	399	A2R3	R	-
TB03	16	399	A5J3	3	-
TB03	17	400	A2R3	C	-
TB03	17	400	A3TB2	4	-
TB03	17	400	A5J3	4	-
TB03	18	0	A2R3	-	SHIELD
TB03	18	0	TB11	-	-
TB03	19	502	A2DS17	(-)	-
TB03	19	502	A6J4	3	-
TB03	20	503	A2DS18	(-)	-
TB03	20	503	A6J4	4	-
TB04	1	342	A2S15	2	-
TB04	1	342	A5J2	19	-
TB04	2	343	A2S15	A	-
TB04	2	343	A5J2	18	-
TB04	3	344	A2S16	2	-
TB04	3	344	A5J2	21	-
TB04	4	345	A2S16	A	-
TB04	4	345	A5J2	20	-
TB04	5	346	A2S17	2	-

Table 13: Terminal Strip A4 Assembly, Wiring List. (Continued)

CONNECTION	TERM	WIRE #	FROM	TERM	NOTES
TB04	5	346	A5J2	23	-
TB04	6	347	A2S17	A	-
TB04	6	347	A5J2	22	-
TB04	7	348	A2S18	2	-
TB04	7	348	A5J2	25	-
TB04	8	349	A2S18	A	-
TB04	8	349	A5J2	24	-
TB04	9	350	A2S19	2	-
TB04	9	350	A5J2	27	-
TB04	10	351	A2S19	A	-
TB04	10	351	A5J2	26	-
TB04	11	352	A2S20	2	-
TB04	11	352	A5J2	29	-
TB04	12	353	A2S20	A	-
TB04	12	353	A5J2	28	-
TB04	13	406	A2S6	1	-
TB04	13	406	A5J2	12	-
TB04	14	404	A2S6	2	-
TB04	14	404	A5J2	10	-
TB04	15	405	A2S6	3	-
TB04	15	405	A5J2	11	-
TB04	16	323	A2DS5	1	-
TB04	16	323	K3	87	-
TB04	17	357	A2S3	3	-
TB04	17	357	A5J2	17	-
TB04	18	354	A2LS1	(+)	-
TB04	18	354	A5J2	16	-
TB04	18	354	TB02	18	-

Table 13: Terminal Strip A4 Assembly, Wiring List. (Continued)

CONNECTION	TERM	WIRE #	FROM	TERM	NOTES
TB04	19	504	A2DS19	(-)	-
TB04	19	504	A6J4	5	-
TB04	20	505	A2DS20	(-)	-
TB04	20	505	A6J4	6	-
TB05	1	394	A3CB8	2	-
TB05	1	394	VR1	+IN	+24V J4 CHARGER
TB05	2	384	A3CB3	2	-
TB05	2	384	A1S10	1	-
TB05	2	384	K1	87	14 GA. WIRE
TB05	3	386	JB1TB1	2	NAV HORN
TB05	3	386	K1	30	14 GA. WIRE
TB05	4	385	A1S10	2	-
TB05	4	385	K1	86	-
TB05	5	383	A1S11	3	-
TB05	5	383	JB1TB1	6	SPOTLIGHT
TB05	6	388	A1S12	3	-
TB05	6	388	JB1TB1	4	WINDSHIELD WIPER
TB05	7	390	A2S4	3	-
TB05	7	390	B1A	1	HEATER
TB05	8	391	A2S4	6	-
TB05	8	391	B1B	1	HEATER
TB05	9	358	A2S3	5	-
TB05	9	358	D1	A	CONNECT DIODE LEAD TO TERM
TB05	10	138	A2S2	6	-
TB05	10	138	A5J4	7	-
TB05	10	138	A6J4	7	-
TB05	11	362	A2S1	5	-
TB05	11	362	D2	Q	CONNECT DIODE LEAD TO TERM

Table 13: Terminal Strip A4 Assembly, Wiring List. (Continued)

CONNECTION	TERM	WIRE #	FROM	TERM	NOTES
TB05	12	359	D1	K	CONNECT DIODE LEAD TO TERM
TB05	12	359	D2	K	CONNECT DIODE LEAD TO TERM
TB05	12	359	LS2	1	-
TB05	13	303	A2S1	11	-
TB05	13	303	A3CB10	2	-
TB05	13	303	TB05	14	JUMPER
TB05	14	303	A1S8	1	-
TB05	14	303	TB05	13	-
TB05	15	442	A2S25	3	-
TB05	15	442	JB1TB1	12	DEFROSTER
TB05	16	301	A1M2	/	-
TB05	16	301	A6J4	11	-
TB05	17	375A	COMPASS	1	-
TB05	17	375A	-	LEAD	COMPASS RESISTOR
TB05	18	301A	A6J4	10	-
TB05	18	301A	A1M2	+	-
TB05	19	375	A1M10	1	SEE RESISTOR
TB05	19	375	A2R1	BLUE	-
TB05	19	375	-	LEAD	COMPASS RESISTOR
TB05	20	0	JB1TB1	1	NAV HORN
TB05	20	0	A1M10	2	-
TB05	20	0	TB11	-	-
TB05	20	0	K1	85	-
TB06	1	409	A1-12	TB03	-
TB06	1	409	A6J3	5	-
TB06	2	410	A1-12	TB05	-
TB06	2	410	A6J3	6	-
TB06	3	0	A1P12	-	SHIELD

Table 13: Terminal Strip A4 Assembly, Wiring List. (Continued)

CONNECTION	TERM	WIRE #	FROM	TERM	NOTES
TB06	3	0	A6J3	7	-
TB06	3	0	A6J3	13	-
TB06	3	0	A6J3	1	-
TB06	3	0	TB11	-	-
TB06	4	411	A1-12	TB01	-
TB06	4	411	A6J3	9	-
TB06	5	412	A1P12	TB02	-
TB06	5	412	A6J3	14	-
TB06	6	506	A2DS21	(-)	-
TB06	6	506	A5J4	1	-
TB06	7	420	A2S23	13	-
TB06	7	420	A6J3	27	-
TB06	8	0	A6J3	20	SHIELD
TB06	8	0	TB07	5	-
TB06	8	0	TB06	9	JUMPER
TB06	9	0	TB06	10	JUMPER
TB06	9	0	A5J3	16	SHIELD
TB06	10	0	A5J3	20	SHIELD
TB06	10	0	TB11	-	-
TB07	1	417	A2S23	23	-
TB07	1	417	A6J3	18	-
TB07	2	419	A2S23	14	-
TB07	2	419	A6J3	19	-
TB07	3	407	A1P12	TB (+)	-
TB07	3	407	A3TB2	7	-
TB07	3	407	A6J3	21	-
TB07	4	418	A2DS8	1	-
TB07	4	418	A6J2	35	-

Table 13: Terminal Strip A4 Assembly, Wiring List. (Continued)

CONNECTION	TERM	WIRE #	FROM	TERM	NOTES
TB07	5	0	A1P12	SHLD	-
TB07	5	0	TB06	8	-
TB07	5	0	A6J3	28	SHIELD
TB07	6	408	A1P12	TB (-)	-
TB07	6	408	A6J3	22	-
TB07	6	408	A3TB2	11	-
TB07	7	507	A2DS22	(-)	-
TB07	7	507	A5J4	2	-
TB07	8	416	A2DS10	2	-
TB07	8	416	A6J2	31	-
TB07	9	508	A5J4	3	-
TB07	10	509	A2DS24	(-)	-
TB07	10	509	A5J4	4	-
TB08	1	423	A1P11	TB03	-
TB08	1	423	A5J3	5	-
TB08	2	424	A1P11	TB05	-
TB08	2	424	A5J3	6	-
TB08	3	0	A5J3	1	-
TB08	3	0	A5J3	7	-
TB08	3	0	A5J3	13	-
TB08	3	0	TB11	-	-
TB08	4	427	A1P11	TB-1	-
TB08	4	427	A5J3	13	-
TB08	5	428	A1P11	TB-2	-
TB08	5	428	A5J3	14	-
TB08	6	510	A2DS25	10	-
TB08	6	510	A5J4	5	-
TB08	7	511	A2DS26	(-)	-

Table 13: Terminal Strip A4 Assembly, Wiring List. (Continued)

CONNECTION	TERM	WIRE #	FROM	TERM	NOTES
TB08	7	511	A5J4	6	-
TB08	8	438	A2S24	13	-
TB08	8	438	A5J3	27	-
TB08	9	440	VR1	+12 OUT	VOLTAGE REGULATOR
TB08	9	440	J4	+12 OUT	CHARGER
TB08	10	0	A4K2	86	-
TB08	10	0	A4K3	86	-
TB08	10	0	TB11	-	-
TB09	1	435	A2S24	23	-
TB09	1	435	A5J3	18	-
TB09	2	437	A2S24	14	-
TB09	2	437	A5J3	19	-
TB09	3	422	A1P11	TB (+)	-
TB09	3	422	A3TB2	6	-
TB09	3	422	AA5J3	21	-
TB09	4	436	A2DS9	1	-
TB09	4	436	A5J2	35	-
TB09	5	0	A5J3	28	SHIELD
TB09	5	0	A1P11	SHLD	-
TB09	5	0	TB11	-	-
TB09	6	434	A1P11	TB (-)	-
TB09	6	4334	A5J3	22	-
TB09	6	434	A3TB2	12	-
TB09	7	302	A5J4	11	-
TB09	7	302	A1M8	/	-
TB09	8	433	A2DS11	2	-
TB09	8	433	A5J2	31	-
TB09	9	302A	A5J4	10	-

Table 13: Terminal Strip A4 Assembly, Wiring List. (Continued)

CONNECTION	TERM	WIRE #	FROM	TERM	NOTES
TB09	9	302A	A1M8	+	-
TB09	10	381	A7TB6	A12	NAV LIGHT SWITCH BOX
TB09	10	381	A3CB1	2	-
TB10	1	360A	A2DS3	2	-
TB10	1	360A	D4	A	-
TB10	2	0	TB10	3	JUMPER
TB10	2	0	D4	K	-
TB10	3	0	A2D17	2	-
TB10	3	0	TB10	4	JUMPER
TB10	3	0	A1P12	-	SHIELD
TB10	3	0	LS2	2	-
TB10	4	0	A1MA0	(-)	-
TB10	4	0	TB10	5	JUMPER
TB10	4	0	LS1	2	-
TB10	5	0	TB11	-	-
TB10	5	0	D3	K	CONNECT DIODE LEAD TO TERM
TB10	5	0	D7	K	-
TB10	6	461	A1DS1	2	-
TB10	6	461	D3	2	CONNECT DIODE LEAD TO TERM
TB10	7	461A	A1DS2	2	-
TB10	7	461A	D7	A	-
TB10	8	368B	LS1	1	-
TB10	8	368B	D5	K	-
TB10	8	368B	D6	K	-
TB10	9	368A	A1S14	5	-
TB10	9	368A	D6	A	-
TB10	10	368	D5	A	-
TB10	10	368	A1S5	5	-

Table 13: Terminal Strip A4 Assembly, Wiring List. (Continued)

CONNECTION	TERM	WIRE #	FROM	TERM	NOTES
TB11	-	0	A5J1	B	-
TB11	-	0	A6J1	B	-
TB11	-	0	B1A/B	2	HEATER
TB11	-	0	B2	2	WINDSHIELD WIPER
TB11	-	0	B3	2	DEFROSTER
TB11	-	0	DS1	2	SPOTLIGHT
TB11	-	0	JB1TB1	3	-
TB11	-	0	JB1TB1	5	-
TB11	-	0	JB1TB1	11	SINGARS
TB11	-	0	A7TB6	A11	NAV. LT. SW. BOX 14 GA. WIRE
TB11	-	0	A3TB2	A	COMMON FOR TEST SW.
TB11	-	0	JB1TB1	9	-
TB11	-	0	JB1TB1	7	VHF-FM
TB11	-	0	A5J2	33	-
TB11	-	0	A5J3	16	-
TB11	-	0	A5J3	20	-
TB11	-	0	A6J3	16	-
TB11	-	0	A6J3	20	-
TB11	-	0	VR1	(-)	-
TB11	-	0	TB01	18	-
TB11	-	0	TB03	18	-
TB11	-	0	TB05	20	-
TB11	-	0	TB06	3	-
TB11	-	0	TB06	10	-
TB11	-	0	TB08	3	-
TB11	-	0	TB08	10	-
TB11	-	0	TB09	5	-
TB11	-	0	TB10	5	14 GA. WIRE

Table 13: Terminal Strip A4 Assembly, Wiring List. (Continued)

CONNECTION	TERM	WIRE #	FROM	TERM	NOTES
 <p>30 86 87A 87 85</p> <p>TERMINAL IDENTIFICATION FOR K1, K2 AND K3 RELAYS</p>					
NOTES:					
1. EXTERNAL WIRES PROVIDED AS PART OF OTHER ASSEMBLY HARNESES, OR OPERATOR CAB WIRING. USE TERMINAL LUGS, ITEM 22, FOR CONNECTION TO TB01 THROUGH TB10, WIRES TO TB11 ONLY REQUIRE STRIPPING. LABEL ALL WIRE ENDS WITH WIRE NUMBER USING HEAT SHRINK TUBING, ITEM 27.					
2. WIRING COMING FROM A5 AND A6 RECEPTACLE ASSEMBLIES TO TERMINATE ON RIGHT HAND SIDE OF TERMINAL STRIPS. WIRING FROM OTHER DEVICES TO TERMINATE ON LEFT HAND OF TERMINAL STRIPS.					
3. ALL INTERNAL WIRES ARE 16 GA. EXCEPT AS NOTED.					
4. TB11 IS MAIN NEGATIVE SIDE TIE POINT FOR 24 VOLT DISTRIBUTION IN THE OPERATOR'S CAB.					
5. ALL POINT TO POINT WIRING ON THE "A4" ASSEMBLY, IS TO BE COMPLETED PRIOR TO TERMINATING WIRES FROM OFF PANEL, EXTERNAL, DEVICES.					

Table 14: Operators Cab Circuit Breaker Panel A3, Internal Connections.

FROM	TERM	ITEM #	WIRE #	SIZE	TO	TERM	ITEM #	NOTES
J1(-)	1	SOLDER	0	16	TB2	1	63	-
-	-	-	-	-	-	-	-	-
TB1	3	-	300A	-	D2	A	-	DIODE LEAD
-	-	-	-	-	-	-	-	-
TB1	2	-	300B	-	D1	A	-	DIODE LEAD
D1	K	50	300	10	D2	K	50	ISOLATE FROM HEAT SINK
D2	K	50	300	10	CB7	1	51	-
CB7	1	51	300	10	CB8	1	51	-
CB7	1	51	300	10	CB1	1	51	-
CB1	1	51	300	10	CB2	1	51	-

Table 14: Operators Cab Circuit Breaker Panel A3, Internal Connections. (Continued)

FROM	TERM	ITEM #	WIRE #	SIZE	TO	TERM	ITEM #	NOTES
CB2	1	51	300	10	CB3	1	51	-
CB3	1	51	300	10	CB4	1	51	-
CB4	1	51	300	10	CB5	1	51	-
CB5	1	51	300	10	CB6	1	51	-
CB8	1	51	300	10	CB9	1	51	-
CB9	1	51	300	10	CB10	1	51	-
-	-	-	-	-	-	-	-	-
-	-	SOLDER	-	-	-	63		-
S1	COMMON	SOLDER	+	LEAD	R1 [12]	1	SOLDER	SWITCH TO R1
R1	2	SOLDER	+	LEAD	J2(+)	1	SOLDER	R1 TO JACK (+)
S1	POS 1	SOLDER	300B	16	TB1	2	56	-
S1	POS 2	SOLDER	300A	16	TB1	3	56	-
S1	POS 3	SOLDER	400	16	TB2	4	17	-
S1	POS 4	SOLDER	397	16	TB2	5	17	-
S1	POS 5	SOLDER	422	16	TB2	6	17	-
S1	POS 6	SOLDER	407	16	TB2	7	17	-
S1	POS 7	SOLDER	N/A [13]	16	TB2	8	17	-
S1	POS 8	SOLDER	N/A	16	TB2	9	17	-
S1	POS 9	SOLDER	N/A	16	TB2	10	17	-
J3	1	SOLDER	408	16	TB2	11	17	-
J4	1	SOLDER	434	16	TB2	12	17	-

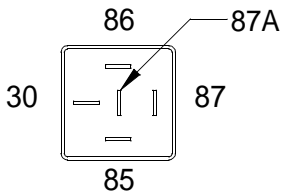
Table 15: Operators Cab Circuit Breaker Panel A3, External Connections.

FROM	TERM	ITEM #	WIRE #	SIZE	TO	TERM	ITEM #	NOTES
TB2	1	17	0	16	MTB11	-	NOT REQ'D	COMMON FOR TEST SW
TB1	2	80	300A	8	A6J1	A	CRIMP PINS	PORT+24VDC POWER
TB1	2	80	300B	8	A5J1	A	CRIMP PINS	STBD +24VDC POWER

Table 15: Operators Cab Circuit Breaker Panel A3, External Connections. (Continued)

FROM	TERM	ITEM #	WIRE #	SIZE	TO	TERM	ITEM #	NOTES
CB10	2	81	303	14	A4TB5	13	17	CONTROL PANEL ALARMS
CB9	2	REF	374	14	A2R1	RED	REF	PANEL LIGHTS-NOTE [14]
CB1	2	81	381	14	A4TB9	10	17	NAVIGATION LIGHTS
CB2	2	REF	382	14	A1S11	2	REF	SPOTLIGHT-NOTE [15]
CB3	2	81	384	14	A4TB5	2	17	NAVIGATION HORN
CB4	2	REF	387	16	A1S12	2	REF	WSHLD WIPER-NOTE [15]
CB5	2	REF	389	16	A2S4	2	REF	HTR/DEFROSTER-NOTE [14]
CB6	2	81	392	16	3JB1TB1	8	17	VHF-FM RADIO
CB7	2	81	393	16	3JB1TB1	10	17	SINCGARS
CB8	2	81	394	16	A4TB5	1	17	VOLTAGE CONVERTER
TB2	5	17	397	16	A4TB1	17	17	THROTTLE CONTROL (P)
TB2	4	17	400	16	A4TB3	17	17	THROTTLE CONTROL (S)
TB2	7	17	407	16	A4TB7	3	17	THRUST INDICATOR (P)
TB2	11	17	408	16	A4TB7	6	17	THRUST INDICATOR (P)
TB2	6	17	422	16	A4TB9	3	17	THRUST INDICATOR (S)

Table 16: Thruster Direction/Auxiliary Battery Junction Box A9, Pass Through Terminations.

WIRE SIZE	FROM	WIRE #	TERM	TO	WIRE #	TERM
14	A4TB2-10	132	14 GA TER LUG	TB1-6	132	COMPRESSION
14	TB1-6	132	COMPRESSION	G1-AC	132	E11028-24
10	B3-1	0	10 GA TER LUG	TB2-18	0	E23808-2
10	S11-2	0	10 GA TER LUG	TB2-18	0	E23808-2
10	B3-2	148	10 GA TER LUG	TB2-19	148	E23808-2
10	S11-1	151	10 GA TER LUG	TB2-20	151	E23808-2

Table 17: Thruster Direction/Auxiliary Battery Junction Box A9, Electrical Internal Wire Connections.

WIRE SIZE	FROM	WIRE #	TERM	TO	WIRE #	TERM
FURNISHED	VR1 BLUE	131	PLUG	TB1-1	131	COMPRESSION
FURNISHED	VR1 ORANGE	130	PLUG	TB1-2	130	COMPRESSION
FURNISHED	VR1 BLACK	0	PLUG	TB1-3	0	COMPRESSION
FURNISHED	VR1 BROWN	124	PLUG	TB1-4	124	COMPRESSION
FURNISHED	VR1 RED	221	PLUG	TB1-5	221	COMPRESSION
FURNISHED	TB1-5	221	COMPRESSION	1S1-1	221	14 GA TER LUG
16	TB1-4	124	COMPRESSION K1-85	124	RELAY TER LUG	
14	TB2-1	0	14 GA TER LUG	K1-86	0	TERM LUG
14	TB2-1	0	14 GA TER LUG	TB2-2	0	14 GA TER LUG
14	TB2-2	0	14 GA TER LUG	TB1-3	0	COMPRESSION
1/0	1S1-1	221	1/0 TER LUG	SH1-L+	221	1/0 TER LUG
1/0	SH1-B+	+24V	1/0 TER LUG	FIELD CONNEC -TIONS		-
1/0	1S1-A	200	1/0 TER LUG	FIELD CONNEC -TION		-
14	1S1-2	202	14 GA TER LUG	TB2-3	202	14 GA TER LUG

Table 17: Thruster Direction/Auxiliary Battery Junction Box A9, Electrical Internal Wire Connections. (Continued)

WIRE SIZE	FROM	WIRE #	TERM	TO	WIRE #	TERM
14	TB2-3	202	.250 WIRE CLIP	BT5 +	202	14 GA TER LUG
14	BT5-	201	.187 WIRE CLIP	BT6 +	201	.250 WIRE CLIP
14	K1-30	203	TER LUG	TB2-4	203	14 GA TER LUG
16	K1-K7	204	TER LUG	VR2-5	204	COMPRESSION
14	V42-1	0	COMPRESSION	TB2-1	0	14 GA TER LUG
16	VR2-6	205	COMPRESSION	TB2-6	205	14 GA TER LUG
16	VR2-2	206	COMPRESSION	TB207	206	14 GA TER LUG
14	BT6-	0	.187 WIRE CLIP	TB2-2	0	14 GA TER LUG
10	SH1-B+	220	10 GA TER LUG	TB2-16	220	10 GA TER LUG
10	SH1-L+	221	10 GA TER LUG	TB2-17	221	10 GA TER LUG

Table 18: Starboard Receptacle A5 Assembly.

CONNECTOR	PIN	TYPE	CABLE WIRE #	SIZE	OPER CAB WIRE #	TO	TERM	LUG	NOTES
J1	A	S	-	8	300B	A3TB1	2	-	+24VDC
J1	B	S	-	8	0	A4TB11	1	-	24 VDC RET
J2	01	C	-	16	-	-	-	-	SPARE
J2	02	C	-	16	322	A4TB3	9	B19	NOTE 2
J2	03	C	-	16	320	A4TB3	10	B19	-
J2	04	C	-	16	367	A4TB3	11	B19	-
J2	05	C	-	16	-	-	-	-	SPARE
J2	06	C	-	16	366	A4TB3	7	B19	-
J2	07	C	-	16	324	A4TB3	5	B19	-
J2	08	C	-	16	305	A4TB3	6	B19	-
J2	09	C	-	16	365A	A4TB3	12	B19	-
J2	10	C	-	16	404	A4TB4	14	B19	-
J2	11	C	-	16	405	A4TB4	15	B19	-
J2	12	C	-	16	406	A4TB4	13	B19	-

Table 18: Starboard Receptacle A5 Assembly. (Continued)

CONNECTOR	PIN	TYPE	CABLE WIRE #	SIZE	OPER CAB WIRE #	TO	TERM	LUG	NOTES
J2	13	C	N/C	16	-	-	-	-	SPARE
J2	14	C	-	16	372	A4TB3	13	B19	-
J2	15	C	-	16	373	A4TB3	14	B19	-
J2	16	C	-	16	354	A4TB4	18	B19	-
J2	17	C	-	16	357	A4TB4	17	B19	-
J2	18	C	-	16	343	A4TB4	2	B19	-
J2	19	C	-	16	342	A4TB4	4	1	B19
J2	20	C	-	16	345	A4TB4	4	B19	-
J2	21	C	-	16	344	A4TB4	3	B19	-
J2	22	C	-	16	347	A4TB4	6	B19	-
J2	23	C	-	16	346	A4TB4	5	B19	-
J2	24	C	-	16	349	A4TB4	8	B19	-
J2	25	C	-	16	348	A4TB4	7	B19	-
J2	26	C	-	16	351	A4TB4	10	B19	-
J2	27	C	-	16	350	A4TB4	9	B19	-
J2	28	C	-	16	353	A4TB4	12	B19	-
J2	29	C	-	16	352	A4TB4	11	B19	-
J2	30	C	N/C	-	-	-	-	-	-
J2	31	C	-	16	433	A4TB9	8	B19	-
J2	32	-	N/C	-	-	-	-	-	SPARE
J2	33	C	-	16	0	A4TB11	2	B19	-
J2	34	C	N/C	-	-	-	-	-	-
J2	35	C	-	16	436	A4TB9	4	B19	-
J2	36	C	N/C	-	-	-	-	-	-
J2	37	C	N/C	-	-	-	-	-	-
J3	1	C	1-SHD	16	0	A4TB8	3	B19	SHIELD
J3	2	C	1-BK	16	398	A4TB3	15	B19	-

Table 18: Starboard Receptacle A5 Assembly. (Continued)

CONNECTOR	PIN	TYPE	CABLE WIRE #	SIZE	OPER CAB WIRE #	TO	TERM	LUG	NOTES
J3	3	C	1-WH	16	399	A4TB3	16	B19	-
J3	4	C	1-RD	16	400	A4TB3	17	B19	-
J3	5	C	2-BK	16	423	A4TB8	1	B19	-
J3	6	C	2-WH	16	424	A4TB8	2	B19	-
J3	7	C	2-SHD	16	0	A4TB8	3	B19	SHIELD
J3	8	C	2-RD	16	-	N/C			SPARE
J3	9	C	3-BK	16	427	A4TB8	4	B19	-
J3	10	C	4-BK	16	325	A4TB3	2	B19	-
J3	11	C	4-WH	16	326	A4TB3	3	B19	-
J3	12	C	4-RD	16	327	A4TB3	1	B19	-
J3	13	C	3-SHD	16	0	A4TB8	3	B19	SHIELD
J3	14	C	3-WH	16	428	A4TB8	5	B19	-
J3	15	C	3-RD	-	-	N/C	-	-	SPARE
-	-	-	-	-	-	-	-	-	-
J3	16	C	4-SHD	16	0	A4TB11	-	B19	SHIELD
J3	17	C	5-BK	16	328	A4TB3	4	B19	
J3	18	C	5-WH	16	435	A4TB9	1	B19	
J3	19	C	5-RD	16	437	A4TB9	2	B19	
J3	20	C	5-SHD	16	0	A4TB11	-		SHIELD
J3	21	C	6-BK	16	422	A4TB9	3	B19	SPARE
J3	22	C	6-WH	16	434	A4TB9	6	B19	SPARE
J3	23	C	7-BK	16	-	N/C	-	-	SPARE
J3	24	C	7-WH	16	-	N/C	-	-	SPARE
J3	25	C	7-RD	16	-	N/C	-	-	SPARE
J3	26	C	7-SHD	16	0	-	-	-	SPARE
J3	27	C	6-RD	16	438	A4TB8	8	B19	-
J3	28	C	6-SHD	16	0	A4TB9	5	-	SHIELD

Table 18: Starboard Receptacle A5 Assembly. (Continued)

CONNECTOR	PIN	TYPE	CABLE WIRE #	SIZE	OPER CAB WIRE #	TO	TERM	LUG	NOTES
J3	29	C	N/C	-	-	-	-	-	-
J3	30	C	N/C	-	-	-	-	-	-
J3	31	C	N/C	-	-	-	-	-	-
J3	32	C	N/C	-	-	-	-	-	-
J3	33	C	N/C	-	-	-	-	-	-
J3	34	C	N/C	-	-	-	-	-	-
J3	35	C	N/C	-	-	-	-	-	-
J3	36	C	N/C	-	-	-	-	-	-
J3	37	C	N/C	-	-	-	-	-	-
J4	1	C	-	16	506	A4TB6	6	B19	-
J4	2	C	-	16	507	A4TB7	7	B19	-
J4	3	C	-	16	508	A4TB7	9	B19	-
J4	4	C	-	16	509	A4TB7	10	B19	-
J4	5	C	-	16	510	A4TB8	6	B19	-
J4	6	C	-	16	511	A4TB8	7	B19	-
J4	7	C	-	16	138	A4TB5	10	B19	-
J4	8	C	-	-	-	-	-	-	SPARE
J4	9	C	-	-	-	-	-	-	SPARE
J4	10	C	-	16	302A	A4TB9	9	B19	-
J4	11	C	-	16	302	A4TB9	7	B19	-
J4	12	C	-	-	-	-	-	-	SPARE
J4	13	C	-	-	-	-	-	-	SPARE
J4	14	C	-	-	-	-	-	-	SPARE
J4	15	C	-	-	-	-	-	-	SPARE
J4	16	C	-	-	-	-	-	-	SPARE

Table 18: Starboard Receptacle A5 Assembly. (Continued)

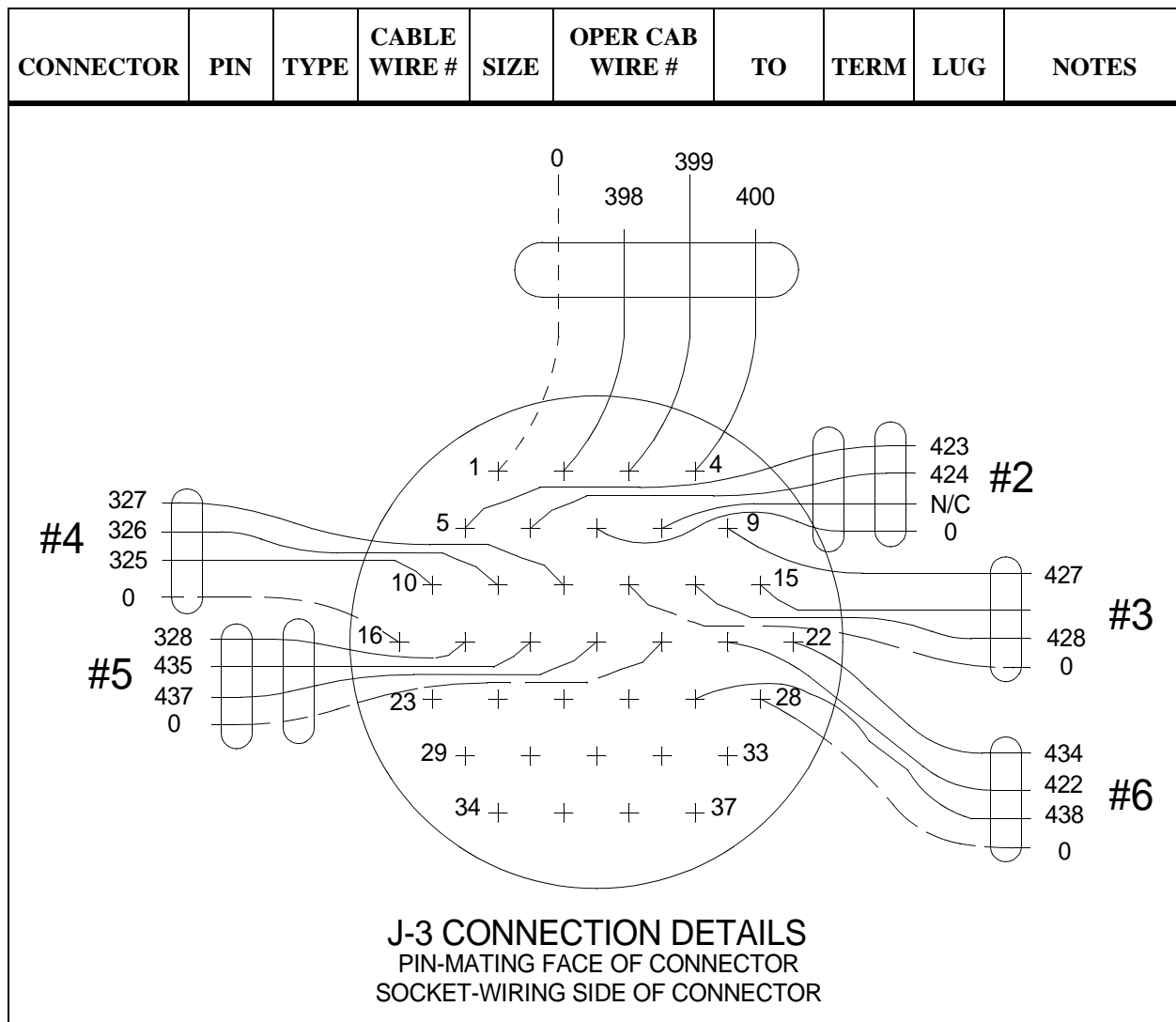

Table 19: Port Receptacle A6 Assembly.

CONNECTOR	PIN	TYPE	CABLE WIRE #	SIZE	OPER CAB WIRE #	TO	TERM	LUG	NOTES
J1	A	S		8	300A	A3TB1	3	-	+24VDC
J1	B	S		8	0	A4TB11	1	-	24 VDC RET
J2	01	C		16	-	-	-		SPARE
J2	02	C		16	312	A4TB1	9	B19	NOTE 2
J2	03	C		16	308	A4TB1	10	B19	-
J2	04	C		16	309	A4TB1	11	B19	-
J2	05	C		16	-	-	-	-	SPARE
J2	06	C		16	306	A4TB1	7	B19	-

Table 19: Port Receptacle A6 Assembly. (Continued)

CONNECTOR	PIN	TYPE	CABLE WIRE #	SIZE	OPER CAB WIRE #	TO	TERM	LUG	NOTES
J2	07	C	-	16	316	A4TB1	5	B19	-
J2	08	C	-	16	304	A4TB1	6	B19	-
J2	09	C	-	16	365	A4TB1	12	B19	-
J2	10	C	-	16	401	A4TB2	14	B19	-
J2	11	C	-	16	402	A4TB2	15	B19	-
J2	12	C	-	16	403	A4TB2	13	B19	-
J2	13	C	N/C	16	-	-	-	-	-
J2	14	C	-	16	370	A4TB2	13	B19	-
J2	15	C	-	16	371	A4TB2	14	B19	-
J2	16	C	-	16	354	A4TB4	18	B19	-
J2	17	C	-	16	361	A4TB2	17	B19	-
J2	18	C	-	16	331	A4TB2	2	B19	-
J2	19	C	-	16	330	A4TB2	1	B19	-
J2	20	C	-	16	333	A4TB2	4	B19	-
J2	21	C	-	16	332	A4TB2	3	B19	-
J2	22	C	-	16	335	A4TB2	6	B19	-
J2	23	C	-	16	334	A4TB2	5	B19	-
J2	24	C	-	16	337	A4TB2	8	B19	-
J2	25	C	-	16	336	A4TB2	7	B19	-
J2	26	C	-	16	339	A4TB2	10	B19	-
J2	27	C	-	16	338	A4TB2	9	B19	-
J2	28	C	-	16	341	A4TB2	12	B19	-
J2	29	C	-	16	340	A4TB2	11	B19	-
J2	30	C	N/C	-	-	-	-	-	-
J2	31	C	-	16	416	A4TB7	8	B19	-
J2	32	-	N/C	-	-	-	-	-	SPARE
J2	33	C	-	16	0	A4TB11	2	B19	-

Table 19: Port Receptacle A6 Assembly. (Continued)

CONNECTOR	PIN	TYPE	CABLE WIRE #	SIZE	OPER CAB WIRE #	TO	TERM	LUG	NOTES
J2	34	C	N/C	-	-	-	-	-	-
J2	35	C		16	418	A4TB7	4	B19	-
J2	36	C	N/C	-	-	-	-	-	-
J2	37	C	N/C	-	-	-	-	-	-
J3	1	C	1-SHD	16	0	A4TB6	3	B19	SHIELD
J3	2	C	1-BK	16	395	A4TB1	15	B19	-
J3	3	C	1-WH	16	396	A4TB1	16	B19	-
J3	4	C	1-RD	16	397	A4TB1	17	B19	-
J3	5	C	2-BK	16	409	A4TB6	1	B19	-
J3	6	C	2-WH	16	410	A4TB6	2	B19	-
J3	7	C	2-SHD	16	0	A4TB6	3	B19	SHIELD
J3	8	C	2-RD	16	-	N/C	-	-	SPARE
J3	9	C	3-BK	16	411	A4TB6	4	B19	-
J3	10	C	4-BK	16	313	A4TB1	2	B19	-
J3	11	C	4-WH	16	314	A4TB1	3	B19	-
J3	12	C	4-RD	16	315	A4TB1	1	B19	-
J3	13	C	3-SHD	16	0	A4TB6	3	B19	SHIELD
J3	14	C	3-WH	16	412	A4TB6	5	B19	-
J3	15	C	3-RD	-	-	-	-	-	SPARE
J3	16	C	4-SHD	16	0	A4TB11	-		SHIELD
J3	17	C	5-BK	16	317	A4TB1	4	B19	-
J3	18	C	5-WH	16	417	A4TB7	1	B19	-
J3	19	C	5-RD	16	419	A4TB7	2	B19	-
J3	20	C	5-SHD	16	0	A4TB11	-	-	SHIELD
J3	21	C	6-BK	16	407	A4TB7	3	B19	SPARE
J3	22	C	6-WH	16	408	A4TB7	6	B19	SPARE
J3	23	C	7-BK	16	-	N/C	-	-	SPARE

Table 19: Port Receptacle A6 Assembly. (Continued)

CONNECTOR	PIN	TYPE	CABLE WIRE #	SIZE	OPER CAB WIRE #	TO	TERM	LUG	NOTES
J3	24	C	7-WH	16	-	N/C	-	-	SPARE
J3	25	C	7-RD	16	-	N/C	-	-	SPARE
J3	26	C	7-SHD	16	0	-	-	-	SPARE
J3	27	C	6-RD	16	420	A4TB6	7	B19	-
J3	28	C	6-SHD	16	0	A4TB7	5		SHIELD
J3	29	C	N/C	-	-	-	-	-	-
J3	30	C	N/C	-	-	-	-	-	-
J3	31	C	N/C	-	-	-	-	-	-
J3	32	C	N/C	-	-	-	-	-	-
J3	33	C	N/C	-	-	-	-	-	-
J3	34	C	N/C	-	-	-	-	-	-
J3	35	C	N/C	-	-	-	-	-	-
J3	36	C	N/C	-	-	-	-	-	-
J3	37	C	N/C	-	-	-	-	-	-
J4	1	C	-	16	500	A4TB1	19	B19	-
J4	2	C	-	16	501	A4TB1	20	B19	-
J4	3	C	-	16	502	A4TB3	19	B19	-
J4	4	C	-	16	503	A4TB3	20	B19	-
J4	5	C	-	16	504	A4TB4	19	B19	-
J4	6	C	-	16	505	A4TB4	20	B19	-
J4	7	C	-	16	138	A4TB5	10	B19	-
J4	8	C	-	-	-	-	-	-	SPARE
J4	9	C	-	-	-	-	-	-	SPARE
J4	10	C	-	16	301A	A4TB5	18	B19	-
J4	11	C	-	16	301	A4TB5	16	B19	-
J4	12	C	-	-	-	-	-	-	SPARE
J4	13	C	-	-	-	-	-	-	SPARE

Table 19: Port Receptacle A6 Assembly. (Continued)

CONNECTOR	PIN	TYPE	CABLE WIRE #	SIZE	OPER CAB WIRE #	TO	TERM	LUG	NOTES
J4	14	C	-	-	-	-	-	-	SPARE
J4	15	C	-	-	-	-	-	-	SPARE
J4	16	C	-	-	-	-	-	-	SPARE

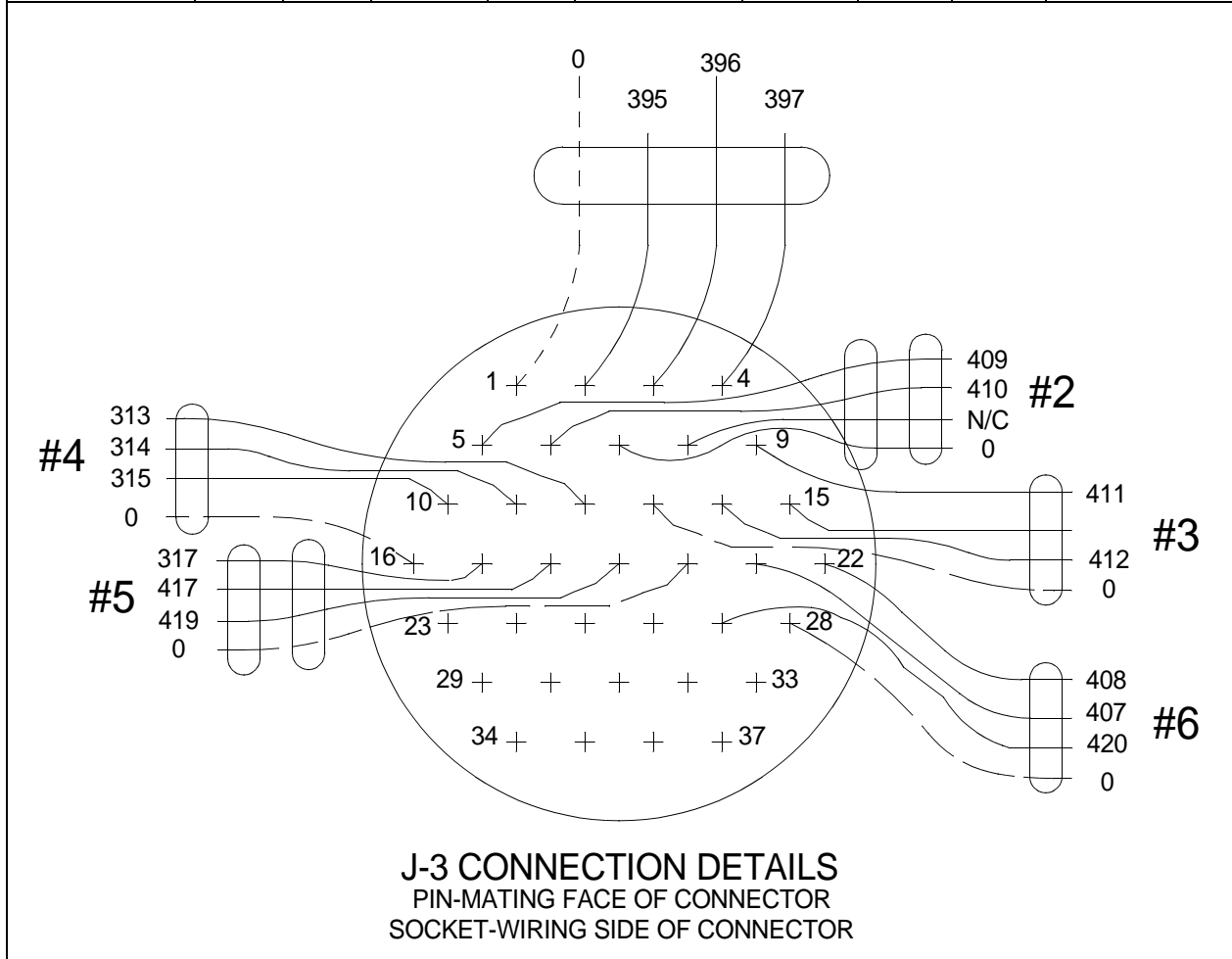

Table 20: Module Electrical Interconnect Assembly.

CONN ITEM #	PIN/ITEM #	TYPE	CABLE COND #	WIRE #	SIZE/AWG
12	A	S	1 WHITE	172	6
12	B	S	2 BLACK	0	6
11	01	17	1	112	16
11	02	17	2	113	16
11	03	17	3	110	16

Table 20: Module Electrical Interconnect Assembly. (Continued)

CONN ITEM #	PIN/ITEM #	TYPE	CABLE COND #	WIRE #	SIZE/AWG
11	04	17	4	111	16
11	05	17	5	114	16
11	06	17	6	115	16
11	07	17	7	124	16
11	08	17	8	104	16
11	09	17	9	129	16
11	10	17	10	173	16
11	11	17	11	174	16
11	12	17	12	175	16
11	13	17	13	SPARE	16
11	14	17	14	134	16
11	15	17	15	135	16
11	16	17	16	139	17
11	17	17	17	141	16
11	18	17	18	143	16
11	19	17	19	145	16
11	20	17	20	148	16
11	21	17	21	150	16
11	22	17	22	153	16
11	23	17	23	155	16
11	24	17	24	158	16
11	25	17	25	160	16
11	26	17	26	163	16
11	27	17	27	165	16
11	28	17	28	168	16
11	29	17	29	170	16
11	30	17	30	181	16
11	31	17	31	180	16

Table 20: Module Electrical Interconnect Assembly. (Continued)

CONN ITEM #	PIN/ITEM #	TYPE	CABLE COND #	WIRE #	SIZE/AWG
11	32	17	32	SPARE	16
11	33	17	33	0	16
11	34	17	34	190	16
11	35	17	35	178	16
11	36	17	36	187	16
11	37	17	37	SPARE	16
13	01	18	1-SHD	0	18
13	02	18	1-BK	119	18
13	03	18	1-WH	121	18
13	04	18	1-RD	120	18
13	05	18	2-BK	185	18
13	06	18	2-WH	186	18
13	07	18	2-SHD	0	18
13	08	18	2-RD	SPARE	18
13	09	18	3-BK	182	18
13	10	18	4-BK	125	18
13	11	18	4-WH	126	18
13	12	18	4-RD	127	18
13	13	18	3-SHD	0	18
13	14	18	3-WH	183	18
13	15	18	3-RD	SPARE	18
13	16	18	R-SHD	0	18
13	17	18	5-BK	132	18
13	18	18	5-WH	212	18
18	19	18	5-RD	211	18
13	20	18	5-SHD	8	18
13	21	18	6-BK	205	18
13	22	18	6-WH	206	18

Table 20: Module Electrical Interconnect Assembly. (Continued)

CONN ITEM #	PIN/ITEM #	TYPE	CABLE COND #	WIRE #	SIZE/AWG
13	23	18	7-BK	SPARE	18
13	24	18	7-WH	SPARE	18
13	25	18	7-RD	SPARE	18
13	26	18	7-SHD	SPARE	18
13	27	18	6-RD	210	18
13	28	18	6-SHD	0	18
13	29	18	N/C	-	16
13	30	18	N/C	-	16
13	31	18	N/C	-	16
13	32	18	N/C	-	16
13	33	18	33	0	16
13	34	18	N/C	-	16
13	35	18	N/C	-	16
13	36	18	N/C	-	16
13	37	18	N/C	-	16
15	A	S	1 WHITE	172	6
15	B	S	2 BLACK	0	6
14	01	18	1	112	16
14	02	18	2	113	16
14	03	18	3	110	16
14	04	18	4	111	16
14	05	18	5	114	16
14	06	18	6	115	16
14	07	18	7	124	16
14	08	18	8	104	16
14	09	18	9	129	16
14	10	18	10	173	16
14	11	18	11	174	16

Table 20: Module Electrical Interconnect Assembly. (Continued)

CONN ITEM #	PIN/ITEM #	TYPE	CABLE COND #	WIRE #	SIZE/AWG
14	12	18	12	175	16
14	13	18	13	SPARE	16
14	14	18	14	134	16
14	15	18	15	135	16
14	16	18	16	139	16
14	17	18	16	141	16
14	18	18	18	143	16
14	19	18	19	145	16
14	20	18	20	148	16
14	21	18	21	150	16
14	22	18	22	153	16
14	23	18	23	155	16
14	24	18	24	158	16
14	25	18	25	160	16
14	26	18	26	163	16
14	27	18	27	165	16
14	28	18	28	168	16
14	29	18	29	170	16
14	30	18	30	181	16
14	31	18	31	180	16
14	32	18	32	SPARE	16
14	33	18	33	0	16
14	34	18	34	190	16
14	35	18	35	178	16
14	36	18	36	187	16
14	37	18	37	SPARE	16
16	01	17	1-SHD	0	18
16	02	17	1-BK	119	18

Table 20: Module Electrical Interconnect Assembly. (Continued)

CONN ITEM #	PIN/ITEM #	TYPE	CABLE COND #	WIRE #	SIZE/AWG
16	03	17	1-WH	121	18
16	04	17	1-RD	120	18
16	05	17	2-BK	185	18
16	06	17	2-WH	186	18
16	07	17	2-SHD	0	18
16	08	17	2-RD	SPARE	18
16	09	17	3-BK	182	18
16	10	17	4-BK	125	18
16	11	17	4-WH	126	18
16	12	17	4-RD	127	18
16	13	17	3-SHD	0	18
16	14	17	3-WH	183	18
16	15	17	3-RD	SPARE	18
16	16	17	4-SHD	0	18
16	17	17	5-BK	132	18
16	18	17	5-WH	212	18
16	19	17	5-RD	211	18
16	20	17	5-SHD	0	18
16	21	17	6-BK	205	18
16	22	17	6-WH	206	18
16	23	17	7-BK	SPARE	18
16	24	17	7-WH	SPARE	18
16	25	17	7-RD	SPARE	18
16	26	17	7-SHD	SPARE	18
16	27	17	6-RD	210	18
16	28	17	6-SHD	0	18
16	29	17	N/C	-	16
16	30	17	N/C	-	16

Table 20: Module Electrical Interconnect Assembly. (Continued)

CONN ITEM #	PIN/ITEM #	TYPE	CABLE COND #	WIRE #	SIZE/AWG
16	31	17	N/C	-	16
16	32	17	N/C	-	16
16	33	17	33	0	16
16	34	17	N/C	-	16
16	35	17	N/C	-	16
16	36	17	N/C	-	16
16	37	17	N/C	-	17
23	01	18	1	146	16
23	02	18	2	151	16
23	03	18	3	156	16
23	04	18	4	161	16
23	05	18	5	166	16
23	06	18	6	171	16
23	07	18	7	138	16
23	08	18	8	SPARE	16
23	09	18	9	SPARE	16
23	10	18	10	220	16
23	11	18	11	221	16
23	12	18	12	SPARE	16
23	13	18	13	SPARE	16
23	14	18	14	SPARE	16
23	15	18	15	SPARE	16
23	16	18	16	SPARE	16
23	N/C	-	17	SPARE	16
23	N/C	-	18	SPARE	16
23	N/C	-	19	SPARE	16
26	01	17	1	146	16
26	02	17	2	151	16

Table 20: Module Electrical Interconnect Assembly. (Continued)

CONN ITEM #	PIN/ITEM #	TYPE	CABLE COND #	WIRE #	SIZE/AWG
26	03	17	3	156	16
26	04	17	4	161	16
26	05	17	5	166	16
26	06	17	6	171	16
26	07	17	7	138	16
26	08	17	8	SPARE	16
26	09	17	9	SPARE	16
26	10	17	10	220	16
26	11	17	11	221	16
26	12	17	12	SPARE	16
26	13	17	13	SPARE	16
26	14	17	14	SPARE	16
26	15	17	15	SPARE	16
26	16	17	16	SPARE	16
26	N/C	-	17	SPARE	16
26	N/C	-	18	SPARE	16
26	N/C	-	19	SPARE	16

CHAPTER 4

**UNIT, DIRECT SUPPORT AND GENERAL SUPPORT
SUPPORTING INFORMATION
FOR
MODULAR CAUSEWAY SYSTEM (MCS)
CAUSEWAY FERRY (CF) ENGINE**

**UNIT, DIRECT SUPPORT AND GENERAL SUPPORT MAINTENANCE
CAUSEWAY FERRY
DIESEL ENGINE
REFERENCES**

SCOPE

This work package lists all field manuals, forms, technical manuals and miscellaneous publications referenced in this manual.

ARMY REGULATIONS

AR 700-138 Army Logistics Readiness and Sustainability

CODE OF FEDERAL REGULATIONS

29 CFR Labor, Parts 1911 to 1925

46 CFR Shipping, Parts 90 to 139

DA PAMPHLETS

DA PAM 738-750 The Army Maintenance Management Systems (TAMMS)

FIELD MANUAL

FM 3-5 NBC, Decontamination

FORMS

DA Form 2028 Recommended Changes to Publications and Blank Forms

DA Form 2028-2 Recommended Changes to Equipment Technical Publications

DA Form 2404 Equipment Inspection and Maintenance Worksheet

SF 361 Transportation Discrepancy Report

SF 368 Product Quality Deficiency Report

MISCELLANEOUS

ASME Y14.38-1999 The American Society of Mechanical Engineers Abbreviations and Acronyms

CTA 8-100 Common Table of Allowances, Army Medical Department Expendable/
Durable Items

CTA 50-970 Common Table of Allowances, Expendable/Durable Items (Except
Medical, Class V Repair Parts, and Heraldic Items)

SUPPLY CATALOG

SC 4910-95-A68	Shop Equipment, Automotive Maintenance and Repair: Field Maintenance, Wheeled Vehicle, Post, Camp and Station, Set C. Less Power
SC 4910-95-A72	Shop Equipment, Automotive Equipment and Repair, Organizational Maintenance
SC 5180-90-N26	Tool Kit, General Mechanics

TECHNICAL BULLETIN

TB 55-1900-207-24	Treatment of Cooling Water in Marine Diesel Engines
-------------------	---

TECHNICAL MANUALS

TM 5-2815-258-24	Unit, Direct Support and General Maintenance Manual for Detroit Diesel Engine Series 53
TM 9-6115-643-24	Unit, Direct Support and General Maintenance Manual for Generator Set, Skid Mounted, Tactical Quiet 15KW
TM 9-6140-200-14	Operator's, Unit, Direct Support and General Support Maintenance Manual for Lead-Acid Storage Batteries
TM 11-5820-890-10-8	SINCGARS Operators Manual
TM 11-5825-291-13	Operations and Maintenance Manual, Satellite Signals Navigation Sets
TM 55-1925-257-14&P	Operator, Unit, Direct Support and General Support Maintenance Manual for Incinerator Toilet/Urinal, Galley Equipment and Electric Water Heater
TM 55-1945-205-10-1	Operators Manual for the Modular Causeway System, Causeway Ferry
TM 55-1945-205-24-1-1	Unit, Direct Support and General Support Maintenance, Causeway Ferry
TM 55-1945-205-24-1-3	Unit, Direct Support and General Maintenance, Causeway Ferry Marine Gear
TM 55-1945-205-24-1-4	Unit, Direct Support and General Maintenance, Causeway Ferry Transfer Case
TM 55-1945-205-24P-1	Unit, Direct Support and General Maintenance, Repair Parts and Special Tools List, Causeway Ferry
TM 750-244-6	Destruction of TACOM Equipment

**UNIT, DIRECT SUPPORT AND GENERAL SUPPORT MAINTENANCE
CAUSEWAY FERRY
DIESEL ENGINE
MAINTENANCE ALLOCATION CHART (MAC)**

INTRODUCTION

The Army Maintenance System MAC

This introduction provides a general explanation of all maintenance and repair functions authorized at various levels under the standard Army Maintenance System concept.

The MAC (immediately following the introduction) designates overall authority and responsibility for the performance of maintenance functions on the identified end item or component. The application of the maintenance functions to the end item or component shall be consistent with the capacities and capabilities of the designated maintenance levels, which are shown on the MAC in column (4) as:

Unit - includes two subcolumns, C (operator/crew) and O (unit) maintenance.

Direct Support - includes an F subcolumn.

General Support - includes an H subcolumn.

Depot - includes a D subcolumn.

The tools and test equipment requirements (immediately following the MAC) list the tools and test equipment (both special tools and common tool sets) required for each maintenance function as referenced from the MAC.

The remarks (immediately following the tools and test equipment requirements) contain supplemental instructions and explanation notes for a particular maintenance function.

Maintenance Functions

Maintenance functions are limited to and defined as follows:

1. Inspect. To determine the serviceability of an item by comparing its physical, mechanical, and/or electrical characteristics with established standards through examination (e.g., by sight, sound or feel).
2. Test. To verify serviceability by measuring the mechanical, pneumatic, hydraulic, or electrical characteristics of an item and comparing those characteristics with prescribed standards on a scheduled basis, i.e., load testing to lift devices and hydrostatic testing of pressure hoses.
3. Service. Operations required periodically to keep an item in proper operating condition; e.g., to clean (includes decontaminate, when required), to preserve, to drain, to paint or to replenish fuel, lubricants, chemical fluids or gases.
4. Adjust. To maintain or regulate, within prescribed limits, by bringing into proper position or by setting the operating characteristics to specified parameters.
5. Align. To adjust specified variable elements of an item to bring about optimum or desired performance.
6. Calibrate. To determine and cause corrections to be made or to be adjusted on instruments of test, measuring and diagnostic equipment used in precision measurement. Consists of comparison of two instruments, one of which is a certified standard of known accuracy, to detect and adjust any discrepancy in the accuracy of the instrument being compared.

7. Remove/Install. To remove and install the same item when required to perform service or other maintenance functions. Install may be the act of emplacing, seating, or fixing into position a spare, repair part or module (component or assembly) in a manner to allow the proper functioning of an equipment or system.
8. Replace. To remove an unserviceable item and install a serviceable counterpart in its place. "Replace" is authorized by the MAC and assigned maintenance level is shown as the third position code of the Source Maintenance and Recoverability (SMR) code.
9. Repair. The application of maintenance services, including fault location/troubleshooting, remove/installation, disassembly/assembly procedures and maintenance actions to identify troubles and restore serviceability to an item by correcting specific damage, fault, malfunction or failure in a part, subassembly, module (component or assembly), end item or system.

NOTE

The following definitions are applicable to the "repair" maintenance function:

Services - Inspect, test, service, adjust, align, calibrate and/or replace.

Fault location/troubleshooting - The process of investigating and detecting the cause of equipment malfunctioning; the act of isolation a fault within system or Unit Under Test (UUT).

Disassembly/assembly - The step-by-step breakdown (taking apart) of a spare/functional group coded item to the level of its least component that is assigned a SMR code for the level of maintenance under consideration (i.e., identified as maintenance significant).

Action - Welding, grinding, riveting, straightening, facing, machining and/or resurfacing.

10. Overhaul. That maintenance effort (service/action) prescribed to restore an item to a completely serviceable/operational condition as required by maintenance standards in appropriate technical publications. Overhaul is normally the highest degree of maintenance performed by the Army. Overhaul does not normally return an item to like new condition.
11. Rebuild. Consist of those services/actions necessary for the restoration of unserviceable equipment to a like new condition in accordance with original manufacturing standards. Rebuild is the highest degree of material maintenance applied to Army equipment. The rebuild operation includes the act of returning to zero those age measurements (e.g., hours/miles) considered in classifying Army equipment/components.

Explanation of Columns in the MAC

Column (1) - Group Number. Column (1) lists FGC numbers, the purpose of which is to identify maintenance significant components, assemblies, subassemblies, and modules with the Next Higher Assembly (NHA).

Column (2) - Component/Assembly. Column (2) contains the item names of components, assemblies, subassemblies, and modules for which maintenance is authorized.

Column (3) - Maintenance Function. Column (3) lists the functions to be performed on the item listed in column (2). (For a detailed explanation of these functions refer to "Maintenance Functions" outlined above)

Column (4) - Maintenance Level. Column (4) specifies each level of maintenance authorized to perform each function listed in column (3), by indicating work time required (expressed as man-hours in whole hours or decimals) in the appropriate subcolumn. This work time figure represents the active time required to perform that maintenance function at the indicated level of maintenance. If the number or complexity of the task within the listed maintenance functions varies at different maintenance levels, appropriate work time figures are to be shown for each level. The

work time figures represents the average time required to restore an item (assembly, subassembly, module, end item or system) to serviceable condition under typical field operating conditions. This time includes preparation time (including any necessary disassembly/assembly time), troubleshooting /fault location time and quality assurance time in addition to the time required to perform the specific task identified for the maintenance functions authorized in the MAC. The symbol designations for the various maintenance levels are as follows:

C - Operator or crew maintenance

O - Unit maintenance

F - Direct support maintenance

L - Specialized repair activity (SRA)

H - General support maintenance

D - Depot maintenance

NOTE

The "L" maintenance level is not included in column (4) of the MAC. Functions to this level of maintenance are identified by a work time figure in the "H" column of column (4), and an associated reference code is used in the REMARKS column (6). This code is keyed to the remarks and the SRA complete repair application is explained there.

Column (5) - Tools and Equipment Reference Code. Column (5) specifies, by code, those common tool sets (not individual tools), common Test, Measurement, and Diagnostic Equipment (TDME), and special tools, special TMDE and special support equipment required to perform the designated function. Codes are keyed to the entries in the tools and test equipment table.

Column (6) - Remarks Code. When applicable, this column contains a letter code, in alphabetical order, which is keyed to the remarks table entries.

Explanation of Columns in the Tools and Test Equipment Requirements

Column (1) - Tool or Test Equipment Reference Code. The tool or test equipment reference code correlates with the code used in column (5) of the MAC.

Column (2) - Maintenance Level. The lowest level of maintenance authorized to use the tool or test equipment.

Column (3) - Nomenclature. Name or identification of the tool or test equipment.

Column (4) - National Stock Number (NSN). The NSN of the tool or test equipment.

Column (5) - Tool Number. The manufacturer's part number, model number, or type number.

Explanation of Columns in the Remarks

Column (1) - Remarks Code. The code recorded in column (6) of the MAC.

Column (2) - Remarks. This column lists information pertinent to the maintenance function being performed as indicated in the MAC.

**UNIT, DIRECT SUPPORT AND GENERAL SUPPORT MAINTENANCE
CAUSEWAY FERRY
DIESEL ENGINE
MAINTENANCE ALLOCATION CHART**

MAINTENANCE ALLOCATION CHART

Table 1. MAC for Modular Causeway System. (MCS)

(1) GROUP NO.	(2) COMPONENT/ASSEMBLY	(3) MAINTENANCE FUNCTION	(4) MAINTENANCE LEVEL					(5) TOOLS AND EQUIP REF CODE	(6) REMARKS CODE
			UNIT		DS	GS	DEPOT		
			C	O	F	H	D		
00	MODULAR CAUSEWAY SYSTEM (MCS)								
01	CAUSEWAY FERRY (CF)								
0101	POWERED SECTION								
010101	POWERED MODULE								
01010101	DRIVE TRAIN								
0101010101	DIESEL ENGINE								A
0101010102	MARINE GEAR								B
0101010103	TRANSFER CASE								C
0101010104	PUMP-JET	Inspect	0.5						E
		Service		3.0			1		E
		Repair					10.0		D
		Replace					50.0		D
010101010401	HYDRAULIC SYSTEM	Inspect	1.0						E
		Service	1.0	3.0			1		E
		Repair			3.0		2, 4, 7		
		Replace			6.0		2, 4, 7		
01010101040101	HYDRAULIC PUMP	Test	0.5						E
		Inspect	1.0						E
		Repair				4.0	2, 4, 7		E

Table 1. MAC for Modular Causeway System. (MCS) (Continued)

(1) GROUP NO.	(2) COMPONENT/ASSEMBLY	(3) MAINTENANCE FUNCTION	(4) MAINTENANCE LEVEL				(5) TOOLS AND EQUIP REF CODE	(6) REMARKS CODE	
			UNIT		DS	GS			DEPOT
			C	O	F	H			D
01010101040101	HYDRAULIC PUMP (CONT'D)	Replace		6.0				1, 2, 4	
01010101040102	HYDRAULIC HAND PUMP	Inspect	1.0						E
		Repair					20.0		
		Replace		2.0				1, 2, 4	
01010101040103	HYDRAULIC WAY-VALVE	Repair				2.0		2, 4, 7	
		Replace		1.5				1, 2, 4	
010101010403	FEEDBACK UNIT	Inspect	1.0						E
		Repair				2.5		2, 4, 7	
		Replace			2.0			2, 4, 7	
0101010105	ALTERNATOR	Test			1.0			7, 14, 15	E
		Inspect	0.5						E
		Replace			2.0			7, 14, 15	
01010102	ENGINE EXHAUST SYSTEM	Clean		2.0				1, 3, 9	E
		Inspect		2.0				1, 3, 9	E
		Repair			6.0			3, 7, 9	
01010103	BILGE PUMP	Test		2.0				1	E
		Inspect	1.0						E
		Replace		8.0				1	F
01010104	FIRE SUPPRESSION SYSTEM	Test					3.0		E
		Inspect	2.0				3.0		E
		Repair					8.0		G
		Replace					24.0		G

Table 1. MAC for Modular Causeway System. (MCS) (Continued)

(1) GROUP NO.	(2) COMPONENT/ASSEMBLY	(3) MAINTENANCE FUNCTION	(4) MAINTENANCE LEVEL					(5) TOOLS AND EQUIP REF CODE	(6) REMARKS CODE
			UNIT		DS	GS	DEPOT		
			C	O	F	H	D		
01010105	FUEL SYSTEM	Test	1.0						E
		Inspect	1.0						E
		Repair			4.0			7	
		Replace			12.0			7	
0101010501	FUEL/WATER SEPARATOR	Clean	1.0						E
		Inspect	1.0						E
		Repair		2.0				1	
		Replace			4.0			7	
01010106	ELECTRICAL SYSTEM	Test			1.0			7, 14, 15	E
		Adjust			1.0			7, 14, 15	
		Repair			2.0			7, 14, 15	
		Replace			8.0			7, 14, 15	
01010107	EMERGENCY STEERING SYSTEM	Inspect	2.0						E
		Service	1.0						E
		Replace		4.0				1	
0101010701	STEERING UNIT	Inspect	0.5						E
		Replace		2.0				1, 2	
0101010702	STEERING ADAPTOR	Inspect	0.5						E
		Replace		1.5				1	
01010108	HULL								
0101010801	EXTERIOR	Clean		4.0				8, 9, 23, 24	E
		Inspect	1.0						E
		Service	1.5						E

Table 1. MAC for Modular Causeway System. (MCS) (Continued)

(1) GROUP NO.	(2) COMPONENT/ASSEMBLY	(3) MAINTENANCE FUNCTION	(4) MAINTENANCE LEVEL				(5) TOOLS AND EQUIP REF CODE	(6) REMARKS CODE	
			UNIT		DS	GS			DEPOT
			C	O	F	H			D
0101010801	EXTERIOR (CONT'D)	Repair		4.0				1, 16	
		Overhaul					24.0		
0101010802	INTERIOR	Clean					4.0		
		Inspect					2.0		
		Test		8.0			5.0	1, 25, 26	E
		Repair					6.0		
		Overhaul					50.0		
01010109	GUILLOTINE FITTINGS	Clean		1.0				8, 9, 23, 24	E
		Inspect	0.5						E
		Repair		3.0				1, 16	
		Replace		1.0				1	
01010110	HATCHES & HINGES	Clean	1.0					8, 9, 23, 24	E
		Inspect	0.5						E
		Service	0.5						E
		Repair		2.0				1, 16	
		Replace		2.0				1	
0101010111	FLEXORS	Inspect	0.5						E
		Replace	4.0						
010102	NON-POWERED MODULES								
01010201	HULL								
0101020101	EXTERIOR	Clean		4.0				8, 9, 23, 24	E
		Inspect	1.0						E
		Service	1.5						E

Table 1. MAC for Modular Causeway System. (MCS) (Continued)

(1) GROUP NO.	(2) COMPONENT/ASSEMBLY	(3) MAINTENANCE FUNCTION	(4) MAINTENANCE LEVEL				(5) TOOLS AND EQUIP REF CODE	(6) REMARKS CODE	
			UNIT		DS	GS			DEPOT
			C	O	F	H			D
0101020102	INTERIOR	Repair		4.0				1, 16	
		Overhaul					24.0		
		Clean					4.0		
		Inspect					2.0		
		Test					5.0	1, 25, 26	E
		Repair					6.0		
01010202	GUILLOTINE FITTINGS	Overhaul					50.0		
		Clean		1.0				8, 9, 23, 24	E
		Inspect	0.5						E
01010203	FLEXORS	Repair		3.0				1, 16	
		Replace		1.0				1	
		Inspect	0.5						E
010103	OPERATORS CAB	Replace	4.0						
01010301	MIDDLE CONTROL PANEL	Test			2.0			7, 14, 15	E
		Inspect			2.0			7, 14, 15	E
		Repair			3.0			7, 14, 15	
		Replace			16.0			7, 14, 15	
01010302	LOWER CONTROL PANEL	Test			2.0			7, 14, 15	E
		Inspect			2.0			7, 14, 15	E
		Repair			3.0			7, 14, 15	
		Replace			16.0			7, 14, 15	

Table 1. MAC for Modular Causeway System. (MCS) (Continued)

(1) GROUP NO.	(2) COMPONENT/ASSEMBLY	(3) MAINTENANCE FUNCTION	(4) MAINTENANCE LEVEL					(5) TOOLS AND EQUIP REF CODE	(6) REMARKS CODE
			UNIT		DS	GS	DEPOT		
			C	O	F	H	D		
01010303	CIRCUIT BREAKER PANEL	Test			1.0			7, 14, 15	E
		Inspect			1.0			7, 14, 15	E
		Repair			2.0			7, 14, 15	
		Replace			12.0			7, 14, 15	
01010304	TERMINAL STRIP A-4	Test			1.0			7, 14, 15	E
		Inspect			1.0			7, 14, 15	E
		Repair			2.0			7, 14, 15	
		Replace			10.0			7, 14, 15	
01010305	SPOTLIGHT	Adjust		1.0				1	
		Replace		1.0				1	
01010306	DEFROSTER	Inspect	1.0						E
		Replace			4.0			7, 14, 15	
01010307	HEATER	Inspect		2.0				1	
		Repair			4.0			7, 14, 15	
		Replace			6.0			7, 14, 15	
01010308	WINDSHIELD WIPER	Repair		1.0				1	
		Replace		2.0				1	
01010309	COMMUNICATIONS EQUIPMENT								
0101030901	VHF/FM HANDHELD TRANSCEIVER	Repair					8.0		
		Replace		1.0				1	

Table 1. MAC for Modular Causeway System. (MCS) (Continued)

(1) GROUP NO.	(2) COMPONENT/ASSEMBLY	(3) MAINTENANCE FUNCTION	(4) MAINTENANCE LEVEL				(5) TOOLS AND EQUIP REF CODE	(6) REMARKS CODE	
			UNIT		DS	GS			DEPOT
			C	O	F	H			D
0101030902	AN/PSN-11 INTERFACE & SWITCHBOX	Repair					6.0		
		Replace			1.0			7, 14, 15	
0101030903	LOUDHAILER	Repair					8.0		
		Replace	0.5						
0101030904	SINGARS RADIO								H
0101030905	VHF/FM DCS TRANSCEIVER	Repair					12.0		
		Replace		1.0					1
01010310	NAVIGATION EQUIPMENT	Test	0.5						E
		Inspect	1.0						E
0101031001	COMPASS	Inspect	2.0.						E
		Replace		2.0				1	
		Calibrate		4.0				1	E
0101031002	PLGR								I
01010311	MAST	Inspect	3.0						E
		Repair		3.0				1	
0101031101	NAVIGATION LIGHTS	Repair			1.0			1	
		Replace			1.0			1	
0101312	OPERATORS CAB ELECTRICAL SYSTEM	Test			4.0			7, 14, 15	E
		Inspect			4.0			7, 14, 15	E
		Repair				6.0		7, 14, 15	
		Replace				10.0		7, 14, 15	

Table 1. MAC for Modular Causeway System. (MCS) (Continued)

(1) GROUP NO.	(2) COMPONENT/ASSEMBLY	(3) MAINTENANCE FUNCTION	(4) MAINTENANCE LEVEL					(5) TOOLS AND EQUIP REF CODE	(6) REMARKS CODE
			UNIT		DS	GS	DEPOT		
			C	O	F	H	D		
010104	ANCHOR ASSEMBLY	Inspect	1.0						E
		Repair		1.0				1	
		Replace		1.0				1	
0102	INTERMEDIATE SECTION								
010201	NON-POWERED MODULES								
01020101	HULL								
0102010101	EXTERIOR	Clean		4.0				8, 9, 23, 24	E
		Inspect	1.0						E
		Service	1.5						E
		Repair		4.0				1, 16	
		Overhaul					24.0		
0102010102	INTERIOR	Clean					4.0		
		Inspect					2.0		
		Test		8.0			5.0	1, 25, 26	E
		Repair					6.0		
		Overhaul					50.0		
01020102	GUILLOTINE FITTINGS	Clean		1.0				8, 9, 23, 24	E
		Inspect	0.5						E
		Repair		3.0				1, 16	
		Replace		1.0				1	
01020103	FLEXORS	Inspect	0.5						E
		Replace	4.0						

Table 1. MAC for Modular Causeway System. (MCS) (Continued)

(1) GROUP NO.	(2) COMPONENT/ASSEMBLY	(3) MAINTENANCE FUNCTION	(4) MAINTENANCE LEVEL				(5) TOOLS AND EQUIP REF CODE	(6) REMARKS CODE	
			UNIT		DS	GS			DEPOT
			C	O	F	H			D
0103	CAUSEWAY FERRY BEACH- END SECTION								
010301	NON-POWERED MODULE								
01030101	HULL								
0103010101	EXTERIOR	Clean		4.0				8, 9, 23, 24	E
		Inspect	1.0						E
		Service	1.5						E
		Repair		4.0				1, 16	
		Overhaul					24.0		
0103010102	INTERIOR	Clean					4.0		
		Inspect					2.0		
		Test		8.0			5.0	1, 25, 26	E
		Repair					6.0		
		Overhaul					50.0		
01030102	GUILLOTINE FITTINGS	Clean		1.0				8, 9, 23, 24	E
		Inspect	0.5						E
		Repair		3.0				1, 16	
		Replace		1.0				1	
01030103	FLEXORS	Inspect	0.5						E
		Replace	4.0						
0104	CONTAINERS	Clean	1.0						E
		Inspect	2.0						E
		Repair			4.0			7	
		Replace					8.0		

Table 1. MAC for Modular Causeway System. (MCS) (Continued)

(1) GROUP NO.	(2) COMPONENT/ASSEMBLY	(3) MAINTENANCE FUNCTION	(4) MAINTENANCE LEVEL					(5) TOOLS AND EQUIP REF CODE	(6) REMARKS CODE
			UNIT		DS	GS	DEPOT		
			C	O	F	H	D		

Table 1. MAC for Modular Causeway System. (MCS) (Continued)

(1) GROUP NO.	(2) COMPONENT/ASSEMBLY	(3) MAINTENANCE FUNCTION	(4) MAINTENANCE LEVEL					(5) TOOLS AND EQUIP REF CODE	(6) REMARKS CODE
			UNIT		DS	GS	DEPOT		
			C	O	F	H	D		
00	MODULAR CAUSEWAY SYSTEM (MCS)								
01	CAUSEWAY FERRY (CF)								
0101010101	DIESEL ENGINE	Inspect	4.0					E	
		Service	4.0	4.0				E	
		Repair				30.0		7, 27-218	
		Replace			120.0			7, 27-218	
		Overhaul					80.0		
010101010101	ENGINE BLOCK ASSEMBLY	Inspect	2.0					E, J	
		Repair				6.0		7, 27-52 J	
		Replace				120.0		7, 27-52 J	
010101010102	CYLINDER HEAD ASSEMBLY	Clean				5.0		7, 53-85 E, K	
		Repair				12.0		7, 53-85 K	
		Inspect			6.0			7, 53-85 E, K	
		Replace			8.0			7, 53-85 K	
010101010103	CRANKSHAFT ASSEMBLY	Repair			16.0			7, 86-106 L	
		Replace			24.0			7, 86-106 L	
010101010104	CAMSHAFT ASSEMBLY	Repair				12.0		7, 131-141	
		Replace				16.0		7, 131-141	
010101010105	FLYWHEEL ASSEMBLY	Inspect			3.0			7, 107-112 M	
		Replace			5.0			7, 107-112 M	

Table 1. MAC for Modular Causeway System. (MCS) (Continued)

(1) GROUP NO.	(2) COMPONENT/ASSEMBLY	(3) MAINTENANCE FUNCTION	(4) MAINTENANCE LEVEL					(5) TOOLS AND EQUIP REF CODE	(6) REMARKS CODE
			UNIT		DS	GS	DEPOT		
			C	O	F	H	D		
010101010106	PISTON ASSEMBLY	Clean				2.0		7, 113-130	N
		Repair				3.0		7, 107-112	M
		Inspect				2.0		7, 113-130	N
		Rebuild				4.5		7, 113-130	N
		Replace				3.0		7, 113-130	N
010101010107	ENGINE BALANCE	Inspect				6.0		7, 131-141	O
		Adjust				3.0		7, 131-141	O
		Replace				8.0		7, 131-141	O
		Repair				8.0		7, 131-141	O
010101010108	FUEL SYSTEM	Inspect	0.5					E, P	
01010101010801	FUEL PUMP	Inspect				1.0		7, 142-187	E
		Repair				4.0		7, 142-187	
		Replace				2.0		7, 142-187	
01010101010802	PRIMING PUMP	Inspect		1.5				1, 142-187	E
		Replace		2.0				1, 142-187	
010101010109	ELECTRIC GOVERNOR	Test			0.5				E
		Adjust		1.0				7, 142-187	
		Repair					5.0		
		Replace		2.0				1, 142-187	
		Inspect	0.5						E, Q
010101010110	AIR INTAKE SYSTEM	Clean		2.0				1, 188-195	E, Q
		Replace		3.0				1, 188-195	Q

Table 1. MAC for Modular Causeway System. (MCS) (Continued)

(1) GROUP NO.	(2) COMPONENT/ASSEMBLY	(3) MAINTENANCE FUNCTION	(4) MAINTENANCE LEVEL					(5) TOOLS AND EQUIP REF CODE	(6) REMARKS CODE
			UNIT		DS	GS	DEPOT		
			C	O	F	H	D		
01010101011001	BLOWER	Inspect			2.0	2.0		7, 188-195	E
		Adjust				4.0		7, 188-195	
		Repair				18.0		7, 188-195	
01010101011002	TURBOCHARGER	Inspect		2.0				1, 188-195	E, R
		Replace			8.0			7, 188-195	
		Repair					18.0		
		Replace			6.0			7, 188-195	
010101010111	LUBE OIL SYSTEM	Service	5.0	5.0					E, S
		Inspect	1.0						E
01010101011101	LUBE OIL PUMP	Inspect				3.0		7, 196-203	E
		Repair				4.0		7, 196-203	
		Replace				4.0		7, 196-203	
01010101011102	LUBE OIL COOLER	Clean			2.0			7	E
		Test			1.5			7, 25, 26	E
		Inspect			2.0			7	E
		Repair			4.0			7	E
		Replace			2.0			7	
010101010112	FRESH WATER COOLING SYSTEM	Inspect	1.0						E, T
		Clean		1.0				1	
01010101011201	FRESH WATER PUMP	Inspect			2.5			7, 212-215	E
		Repair			6.0			7, 212-215	
		Replace			3.0			7, 212-215	
		Test			2.0			7, 25, 26	E

Table 1. MAC for Modular Causeway System. (MCS) (Continued)

(1) GROUP NO.	(2) COMPONENT/ASSEMBLY	(3) MAINTENANCE FUNCTION	(4) MAINTENANCE LEVEL					(5) TOOLS AND EQUIP REF CODE	(6) REMARKS CODE
			UNIT		DS	GS	DEPOT		
			C	O	F	H	D		
01010101011202	FRESH WATER COOLER	Clean			2.0			7	E
		Inspect			1.0			7	E
		Repair			4.0			7	
		Replace			3.0			7	
010101010113	RAW WATER COOLING SYSTEM	Inspect	1.0					E, U	
01010101011301	RAW WATER PUMP	Inspect		2.0				1	E
		Clean		2.0				1	E, U
		Repair			4.0			7, 212-215	
		Replace		2.5				1, 212-215	
010101010114	ELECTRICAL SYSTEM	Test			4.0			7, 14, 15	E, V
		Inspect			2.0			7, 14, 15	E, V
		Repair			3.0			7, 14, 15	V
		Replace			16.0			1, 7, 14, 15	V
01010101011401	STARTER	Inspect	1.0						E
		Repair				6.0		7, 14, 15	
		Replace		3.0				1, 14, 15	
01010101011402	COLD PACK STARTER	Clean		1.0				1	E
		Inspect	0.5						E
		Adjust		1.0				1, 14, 15	
		Repair		2.5				1, 14, 15	
		Replace		3.0				1, 14, 15	

Table 1. MAC for Modular Causeway System. (MCS) (Continued)

(1) GROUP NO.	(2) COMPONENT/ASSEMBLY	(3) MAINTENANCE FUNCTION	(4) MAINTENANCE LEVEL					(5) TOOLS AND EQUIP REF CODE	(6) REMARKS CODE
			UNIT		DS	GS	DEPOT		
			C	O	F	H	D		
010101010115	OVER SPEED GOVERNOR	Test				1.0		7	E
		Adjust				1.5		7, 184-187	
		Repair				5.0		7, 184-187	
		Replace				4.0		7, 184-187	
010101010116	AUTO SHUTDOWN SYSTEM	Test		1.0					E
		Adjust			2.0			7, 14, 15	
		Repair				6.0		7, 14, 15	
		Replace		4.0			8.0	1	

Table 1. MAC for Modular Causeway System. (MCS) (Continued)

(1) GROUP NO.	(2) COMPONENT/ASSEMBLY	(3) MAINTENANCE FUNCTION	(4) MAINTENANCE LEVEL					(5) TOOLS AND EQUIP REF CODE	(6) REMARKS CODE
			UNIT		DS	GS	DEPOT		
			C	O	F	H	D		

Table 1. MAC for Modular Causeway System. (MCS) (Continued)

(1) GROUP NO.	(2) COMPONENT/ASSEMBLY	(3) MAINTENANCE FUNCTION	(4) MAINTENANCE LEVEL					(5) TOOLS AND EQUIP REF CODE	(6) REMARKS CODE
			UNIT		DS	GS	DEPOT		
			C	O	F	H	D		
00	MODULAR CAUSEWAY SYSTEM (MCS)								
01	CAUSEWAY FERRY (CF)								
0101010102	MARINE GEAR	Inspect	1.0					E	
		Align			2.0		7, 17		
		Service	1.0	4.0			1	E	
		Rebuild					25.0	W	
		Replace			28.0		4, 7, 17		
010101010201	OIL SYSTEM	Inspect	0.5					E, X	
		Repair		.5			1, 11	X	
01010101020101	OIL COOLER	Clean	1.0					E	
		Inspect	1.0					E	
		Replace		4.0			1		
01010101020102	LINES & HOSES	Inspect	0.5					E	
		Repair		1.0			1		
01010101020103	OIL PUMP	Inspect	1.0					E	
		Repair		2.0			1, 3		
01010101020104	ELECTRIC CONTROL VALVE	Repair					8.0		
		Replace			6.0		7, 14, 15		
010101010202	GEAR MOUNTS	Inspect	.05					E	
		Replace			2.0		3,7		
010101010203	COUPLING BLOCKS	Clean			1.0		7	E	
		Inspect			1.0		7	E	
		Replace			4.0		3, 7		

Table 1. MAC for Modular Causeway System. (MCS) (Continued)

(1) GROUP NO.	(2) COMPONENT/ASSEMBLY	(3) MAINTENANCE FUNCTION	(4) MAINTENANCE LEVEL					(5) TOOLS AND EQUIP REF CODE	(6) REMARKS CODE
			UNIT		DS	GS	DEPOT		
			C	O	F	H	D		
010101010204	OUTPUT FLANGE	Inspect	0.5						E
		Align			2.0			3, 7, 17	
		Replace			4.0			3, 7, 17	
010101010205	OUTPUT SEAL	Inspect			2.0			7	E
		Replace			2.0			3, 7	
010101010206	INPUT FLANGE (ENGINE CONNECTION)	Inspect	0.5						E

Table 1. MAC for Modular Causeway System. (MCS) (Continued)

(1) GROUP NO.	(2) COMPONENT/ASSEMBLY	(3) MAINTENANCE FUNCTION	(4) MAINTENANCE LEVEL					(5) TOOLS AND EQUIP REF CODE	(6) REMARKS CODE
			UNIT		DS	GS	DEPOT		
			C	O	F	H	D		
00	MODULAR CAUSEWAY SYSTEM (MCS)								
01	CAUSEWAY FERRY (CF)								
0101010103	TRANSFER CASE	Clean		2.0				1	E
		Service	1.0	4.0				1	E
		Overhaul				24.0			
		Rebuild					24.0	2, 7, 17	Y
		Replace			24.0			2, 7, 17	
010101010301	OIL SYSTEM	Inspect	1.0						E
		Repair		2.5				1	
01010101030101	OIL PUMP	Inspect	4.0						E
		Replace		2.5				1	
01010101030102	HOSES & FITTINGS	Inspect	0.2						E
		Replace		2.0				1	
01010101030103	OIL COOLER	Inspect	0.2						E
010101010302	GEAR SHAFT	Inspect				5.0		7	E
		Replace		3.5				1	
		Repair				8.0		3, 7, 17	
		Replace				7.0		3, 7, 17, 19	
01010101030201	UPPER SHAFT	Inspect				5.0		7	X E
		Repair				8.0		3, 7, 17	
		Replace				7.0		3, 7, 17, 19	

Table 1. MAC for Modular Causeway System. (MCS) (Continued)

(1) GROUP NO.	(2) COMPONENT/ASSEMBLY	(3) MAINTENANCE FUNCTION	(4) MAINTENANCE LEVEL					(5) TOOLS AND EQUIP REF CODE	(6) REMARKS CODE
			UNIT		DS	GS	DEPOT		
			C	O	F	H	D		
0101010103020101	INPUT SEAL	Clean			2.0			7	E
		Inspect			2.0			7	E
		Replace			2.0			3, 7, 17, 19	
0101010103020102	OUTPUT SEAL	Clean			2.0			7	E
		Inspect			2.0			7	E
		Replace			2.0			3, 7, 17, 19	
01010101030202	INTERMEDIATE SHAFT	Inspect				2.5		7	E
		Repair				5.5		3, 7, 17	
		Replace				6.5		3, 7, 17, 19	
01010101030203	LOWER SHAFT	Inspect				4.0		7	E
		Repair				8.0		3, 7, 17	
		Replace				6.0		3, 7, 17, 19	
0101010103020301	INPUT SEAL	Clean			2.0			7	E
		Replace			2.0			3, 7, 17, 19	
		Inspect			2.0			7	E

Table 1. MAC for Modular Causeway System. (MCS) (Continued)

(1) GROUP NO.	(2) COMPONENT/ASSEMBLY	(3) MAINTENANCE FUNCTION	(4) MAINTENANCE LEVEL					(5) TOOLS AND EQUIP REF CODE	(6) REMARKS CODE
			UNIT		DS	GS	DEPOT		
			C	O	F	H	D		
00	MODULAR CAUSEWAY SYSTEM (MCS)								
01	CAUSEWAY FERRY (CF)								
02	ROLL-ON/ROLL- OFF DISCHARGE FACILITY (RRDF)								
0201	INTERMEDIATE SECTION								
020101	NON-POWERED MODULE								
02010101	HULL								
0201010101	EXTERIOR	Clean		4.0				8, 9, 23, 24	E
		Inspect	1.0						E
		Repair		4.0				1, 16	
		Service	1.5						E
		Overhaul					24.0		
		Inspect					2.0		
0201010102	INTERIOR	Clean					4.0		
		Test		6.0			5.0	1, 25, 26	E
		Repair					6.0		
02010102	GUILLOTINE FITTINGS	Clean		1.0				8, 9, 23, 24	E
		Overhaul					50.0		
		Inspect	0.5						E
		Repair		3.0				1, 16	
		Replace		1.0				1	

Table 1. MAC for Modular Causeway System. (MCS) (Continued)

(1) GROUP NO.	(2) COMPONENT/ASSEMBLY	(3) MAINTENANCE FUNCTION	(4) MAINTENANCE LEVEL					(5) TOOLS AND EQUIP REF CODE	(6) REMARKS CODE
			UNIT		DS	GS	DEPOT		
			C	O	F	H	D		
02010103	FLEXORS	Inspect	0.5						E
		Replace	4.0						
0202	COMBINATION BEACH-END SECTION								
020201	NON-POWERED MODULE								
02020101	HULL								
0202010101	EXTERIOR	Clean		4.0				8, 9, 23, 24	E
		Inspect	1.0						E
		Service	1.5						E
		Repair		4.0				1, 16	
		Overhaul					24.0		
		Inspect					2.0		
0202010102	INTERIOR	Clean					4.0		
		Test		6.0			5.0	1, 25, 26	E
		Repair					6.0		
		Overhaul					50.0		
02020102	GUILLOTINE FITTINGS	Clean		1.0				8, 9, 23, 24	E
		Inspect	0.5						E
		Repair		3.0				1, 16	
		Replace		1.0				1	
02020103	FLEXORS	Inspect	0.5						E
		Replace	4.0						
0203	GENERATOR SHELTER			4.0				1	

Table 1. MAC for Modular Causeway System. (MCS) (Continued)

(1) GROUP NO.	(2) COMPONENT/ASSEMBLY	(3) MAINTENANCE FUNCTION	(4) MAINTENANCE LEVEL					(5) TOOLS AND EQUIP REF CODE	(6) REMARKS CODE
			UNIT		DS	GS	DEPOT		
			C	O	F	H	D		
020301	ARMY TACTICAL QUIET GENERATOR (ATQG)								AD
020302	FUEL SYSTEM	Inspect	1.0						E
		Repair			1.5			7	
		Replace		1.0				1	
02030201	MANUAL FUEL PUMP	Clean		1.0				1	E
		Inspect	1.0	1.0				1	E
		Repair		2.0				1	
		Replace		2.0				1	
020303	LOUVERS	Clean		1.0				1	E
		Inspect	1.0						E
		Service		1.0				1	E
		Repair		3.0				1	
		Replace		4.0				1	
020304	ELECTRICAL SYSTEM	Test			2.0			7, 14, 15	E
		Repair		2.0	3.0			1, 7, 14, 15	
		Replace			5.0			7, 14, 15	
020305	FIRE SUPPRESSION SYSTEM	Test					4.0		E, G
		Inspect	1.0						E
		Repair					4.0	1, 14, 15	G
		Replace					40.0		G
0204	PERSONNEL SHELTER								

Table 1. MAC for Modular Causeway System. (MCS) (Continued)

(1) GROUP NO.	(2) COMPONENT/ASSEMBLY	(3) MAINTENANCE FUNCTION	(4) MAINTENANCE LEVEL					(5) TOOLS AND EQUIP REF CODE	(6) REMARKS CODE
			UNIT		DS	GS	DEPOT		
			C	O	F	H	D		
020401	HEAT PUMP	Clean		4.0				1	E
		Inspect		1.0				1	E
		Service			3.0			7, 21	E
		Repair		2.0	4.0			1, 7, 14, 15, 21	
		Replace			8.0			7, 14, 15, 21	
		Rebuild				8.0		7, 14, 15, 21	
020402	INCINOLET							AE	
020403	ELECTRICAL SYSTEM	Inspect	2.0						E
		Repair		12.0	3.0			1, 7, 14, 15	
		Replace			12.0			7, 14, 15	
020404	COMMUNICATIONS EQUIPMENT								
02040401	VHF\FM HANDHELD TRANSCEIVER	Replace	1.0						
		Repair					8.0		
0205	LIGHT TOWER								
020501	ELECTRICAL SYSTEM	Inspect			0.5			10, 15	E
		Test			1.0			10, 15	E
02050101	BATTERIES	Repair			6.0			10, 15	
		Test			1.0			10, 13	E
		Inspect	0.5						E
		Replace		2.0			1		

Table 1. MAC for Modular Causeway System. (MCS) (Continued)

(1) GROUP NO.	(2) COMPONENT/ASSEMBLY	(3) MAINTENANCE FUNCTION	(4) MAINTENANCE LEVEL					(5) TOOLS AND EQUIP REF CODE	(6) REMARKS CODE
			UNIT		DS	GS	DEPOT		
			C	O	F	H	D		
02050102	OIL PRESSURE UNIT	Test			1.0			10	E
		Repair			1.0			10	
		Replace			1.5			10	
02050103	STARTING CIRCUIT	Repair			2.0			10, 15	
		Replace			3.0			10, 15	
02050104	ENGINE TEMPERATURE UNIT	Test			1.0			10, 18	E
		Replace			2.5			10, 18	
		Repair			2.0			10, 18	
02050105	HOURMETER UNIT	Repair			1.5			10	
		Replace			2.0			10	
02050106	SHUTDOWN CIRCUIT	Repair			2.0			10	
		Replace			4.0			10	
02050107	LAMP SYSTEM	Test	1.0						E
		Repair			2.0			10, 15	
		Replace			6.0			10, 15	
02050108	LAMP BALLAST SYSTEM	Test			0.5			10, 15	E
		Repair			2.0			10, 15	
		Replace			3.0			10, 15	
020502	GENERATOR	Clean		2.0				1	E
		Inspect					12.0		
		Repair					18.0		
		Replace					24.0		

Table 1. MAC for Modular Causeway System. (MCS) (Continued)

(1) GROUP NO.	(2) COMPONENT/ASSEMBLY	(3) MAINTENANCE FUNCTION	(4) MAINTENANCE LEVEL					(5) TOOLS AND EQUIP REF CODE	(6) REMARKS CODE
			UNIT		DS	GS	DEPOT		
			C	O	F	H	D		
02050202	CONTROL PANEL	Inspect	1.0						E
		Repair			3.0			10, 15	
		Replace			4.5			10, 15	
02050205	DIESEL ENGINE	Service	4.0	2.0				1	E
		Adjust		3.0				1	
		Overhaul					16.0		
		Repair				16.0		10	
		Replace			16.0			10	
0205020501	ENGINE FUEL SYSTEM	Inspect	1.0						E
		Repair		4.0				1	
		Replace			8.0			10	
020502050101	FUEL PUMP	Inspect	1.0						E
		Repair				4.0		10	
		Replace			5.0			10	
020502050102	FUEL TANK	Clean	2.0						E
		Inspect	1.0						E
		Repair		2.0				1	
		Replace		2.0				1	
0205020502	ENGINE AIR SYSTEM	Inspect	1.0						E
		Repair		2.0				1	
		Replace		4.0				1	
0205020503	ENGINE COOLING SYSTEM	Inspect	1.0						E
		Repair		3.0				1	
		Replace		2.0		5.0		1, 10	

Table 1. MAC for Modular Causeway System. (MCS) (Continued)

(1) GROUP NO.	(2) COMPONENT/ASSEMBLY	(3) MAINTENANCE FUNCTION	(4) MAINTENANCE LEVEL					(5) TOOLS AND EQUIP REF CODE	(6) REMARKS CODE
			UNIT		DS	GS	DEPOT		
			C	O	F	H	D		
020502050301	FAN ASSEMBLY	Inspect	0.5						E
		Repair		1.5				1	
		Replace		2.0				1	
020502050302	COOLING WATER PUMP	Inspect			1.0			10	E
		Repair				4.0		10	
		Replace			5.0			10	
020502050303	RADIATOR	Clean	1.0						E
		Inspect		1.0				1	E
		Service	2.0	4.0				1	E
		Repair				4.0		10	
		Replace		2.0	3.0			1, 10	
0205020504	CYLINDER HEAD	Inspect		1.0				1	E
		Adjust					2.0		
		Repair					8.0		
		Replace					5.0		
0205020505	VIBRATION DAMPER	Repair					4.0		
		Replace					4.0		
0205020506	EXHAUST SYSTEM	Clean	1.5						E
		Inspect	1.0						E
		Repair		3.0				1, 16	
		Replace		5.0				1	
0205020507	CRANKSHAFT	Inspect					4.0		
		Repair					8.0		
		Replace					8.0		

Table 1. MAC for Modular Causeway System. (MCS) (Continued)

(1) GROUP NO.	(2) COMPONENT/ASSEMBLY	(3) MAINTENANCE FUNCTION	(4) MAINTENANCE LEVEL					(5) TOOLS AND EQUIP REF CODE	(6) REMARKS CODE
			UNIT		DS	GS	DEPOT		
			C	O	F	H	D		
0205020508	PISTON	Inspect					4.0		
		Repair					4.0		
		Replace					4.0		
02050206	RUNNING GEAR	Service		2.0				1	E
		Repair		2.0		2.0		1, 10	
		Replace		18.0				1	
0205020601	TIRES	Inspect	0.5						E
		Repair				1.0		10	
		Replace				1.0		10	
02050207	SUPPORT TOWER	Inspect	0.5						E
		Service	1.0						E
		Repair			2.0			10	
		Replace			6.0			10	
02050208	TOWER RAISING ASSEMBLY	Inspect	0.5						E
		Repair			1.0			10	
		Replace			3.0			10	
02050209	ENCLOSURE	Inspect	0.5						E
		Repair			2.0			10	
		Replace			6.0			10	
0206	EASY ANCHOR	Inspect	2.0						E
		Service		1.0				1	E
		Repair			4.0			6, 7	
		Replace			6.0			6, 7	
0207	RHIB (ZODIAC)								

Table 1. MAC for Modular Causeway System. (MCS) (Continued)

(1) GROUP NO.	(2) COMPONENT/ASSEMBLY	(3) MAINTENANCE FUNCTION	(4) MAINTENANCE LEVEL					(5) TOOLS AND EQUIP REF CODE	(6) REMARKS CODE
			UNIT		DS	GS	DEPOT		
			C	O	F	H	D		
020701	STEERING & THROTTLE	Inspect	1.0						E
		Service	1.0						E
		Repair			4.0			10	
		Replace			8.0			10	
020702	CONTROL PANEL	Inspect			2.0			10, 15	E
		Repair			4.0			10, 15	
		Replace			6.0			10, 15	
020703	BOAT HULL	Inspect	1.0						E
		Repair		2.0		20.0		1, 219-230	
		Replace				18.0		1, 219-230	
020704	NAVIGATION SYSTEM	Repair			3.0		12.0	7	
		Replace		2.0				1	
020705	OUTBOARD ENGINE	Test		4.0					E
		Repair					12.0		
		Rebuild					12.0		
		Replace		4.0					
02070501	ENGINE COVER	Inspect	1.0						E
		Repair			2.0			10	
		Replace			2.0			10	
02070502	LOWER ENGINE COVER	Inspect	1.0						E
		Repair			2.0			10	
		Replace			2.0			10	

Table 1. MAC for Modular Causeway System. (MCS) (Continued)

(1) GROUP NO.	(2) COMPONENT/ASSEMBLY	(3) MAINTENANCE FUNCTION	(4) MAINTENANCE LEVEL					(5) TOOLS AND EQUIP REF CODE	(6) REMARKS CODE
			UNIT		DS	GS	DEPOT		
			C	O	F	H	D		
02070503	ELECTRICAL STARTER	Repair			2.0			10, 15	
		Replace			3.0			10, 15	
02070504	POWER TRIM/TILT ELECTRICAL	Adjust		1.0				1	
		Repair			2.0			10, 15	
		Replace			2.5			10, 15	
02070505	IGNITION	Repair					8.0		
		Replace					8.0	2, 17	
02070506	INTAKE MANIFOLD	Inspect			1.0			10	E
		Repair			3.0			10	
		Replace			3.0			10	
02070507	CARBURETOR	Adjust		1.0				1	
		Repair			3.0			10	
		Replace			3.0			10	
02070508	ELECTRIC PRIMER SYSTEM	Repair			3.0			10, 15	
		Replace			2.0			10, 15	
02070509	FUEL TANK	Inspect	1.0						E
		Repair			3.0			10	
		Replace	2.0						
02070510	FUEL HOSE & PRIMER BULB	Repair		1.0				1	
		Replace	1.0						
02070511	FUEL PUMP	Repair			2.0			10	
		Replace			2.0			10	

Table 1. MAC for Modular Causeway System. (MCS) (Continued)

(1) GROUP NO.	(2) COMPONENT/ASSEMBLY	(3) MAINTENANCE FUNCTION	(4) MAINTENANCE LEVEL					(5) TOOLS AND EQUIP REF CODE	(6) REMARKS CODE
			UNIT		DS	GS	DEPOT		
			C	O	F	H	D		
02070512	CRANKSHAFT & PISTON	Inspect					6.0		
		Repair					8.0		
		Replace					8.0		
02070513	CYLINDER & CRANKCASE	Inspect					6.0		
		Rebuild					16.0		
		Replace					8.0		
02070514	EXHAUST HOUSING	Inspect	1.0						E
		Repair			3.0			10	
		Replace			3.0			10	
02070515	POWER TRIM/TILT HYDRAULIC	Repair					4.0		
		Replace					3.0		
02070516	POWER TRIM/TILT MIDSECTION	Inspect					2.0		
		Repair					4.0		
		Replace					4.0		
02070517	GEARCASE	Inspect			3.0			10	E
		Repair					8.0		
		Replace					8.0		
0207051701	BEARING HOUSING ASSEMBLY	Inspect					2.0		
		Repair					3.0		
		Replace					3.0		

Table 1. MAC for Modular Causeway System. (MCS) (Continued)

(1) GROUP NO.	(2) COMPONENT/ASSEMBLY	(3) MAINTENANCE FUNCTION	(4) MAINTENANCE LEVEL					(5) TOOLS AND EQUIP REF CODE	(6) REMARKS CODE
			UNIT		DS	GS	DEPOT		
			C	O	F	H	D		
0207051702	PROPELLER SHAFT ASSEMBLY	Inspect					2.0		
		Repair					4.0		
		Replace					3.0		
0207051703	IMPELLER ASSEMBLY	Inspect					4.0		
		Repair					4.0		
		Replace					4.0		
0207051704	WATER PUMP ASSEMBLY	Inspect					4.0		
		Repair					4.0		
		Rebuild					8.0		
		Replace					4.0		
02070518	STEERING LINK KIT	Inspect	1.0						E
		Repair		1.0				1	
		Replace		2.0				1	
02070519	BATTERY	Test			2.0			10, 13	
		Service			2.0			10	
		Replace			2.0			10	
0207051901	BATTERY CABLE	Clean	0.5						
		Inspect	0.5						E
		Repair		1.0				1	
		Replace		1.0				1	
020706	FIRE EXTINGUISHER	Inspect	0.5						E
		Replace	2.0						E

Table 1. MAC for Modular Causeway System. (MCS) (Continued)

(1) GROUP NO.	(2) COMPONENT/ASSEMBLY	(3) MAINTENANCE FUNCTION	(4) MAINTENANCE LEVEL					(5) TOOLS AND EQUIP REF CODE	(6) REMARKS CODE
			UNIT		DS	GS	DEPOT		
			C	O	F	H	D		
0208	CONTAINERS	Inspect	2.0						E
		Clean	1.0						E
		Repair			4.0			7	
		Replace					8.0		

Table 1. MAC for Modular Causeway System. (MCS) (Continued)

(1) GROUP NO.	(2) COMPONENT/ASSEMBLY	(3) MAINTENANCE FUNCTION	(4) MAINTENANCE LEVEL					(5) TOOLS AND EQUIP REF CODE	(6) REMARKS CODE
			UNIT		DS	GS	DEPOT		
			C	O	F	H	D		

Table 1. MAC for Modular Causeway System. (MCS) (Continued)

(1) GROUP NO.	(2) COMPONENT/ASSEMBLY	(3) MAINTENANCE FUNCTION	(4) MAINTENANCE LEVEL					(5) TOOLS AND EQUIP REF CODE	(6) REMARKS CODE
			UNIT		DS	GS	DEPOT		
			C	O	F	H	D		
00	MODULAR CAUSEWAY SYSTEM (MCS)								
01	CAUSEWAY FERRY (CF)								
02	ROLL-ON/ROLL- OFF DISCHARGE FACILITY (RRDF)								
03	MODULAR WARPING TUG (WT)								
0301	POWERED SECTION								
030101	POWERED MODULE								
03010101	DRIVE TRAIN								
0301010101	DIESEL ENGINE							Z	
0301010102	MARINE GEAR							AA	
0301010103	TRANSFER CASE							AB	
0301010104	PUMP-JET ASSEMBLY	Inspect	0.5					E	
		Service		3.0			1	E	
		Repair				10.0		D	
		Replace				50.0			
030101010401	HYDRAULIC SYSTEM	Inspect	1.0				1	E	
		Service	1.0	3.0			1	E	
		Repair			3.0		2, 4, 7		
		Replace			6.0		2, 4, 7		

Table 1. MAC for Modular Causeway System. (MCS) (Continued)

(1) GROUP NO.	(2) COMPONENT/ASSEMBLY	(3) MAINTENANCE FUNCTION	(4) MAINTENANCE LEVEL					(5) TOOLS AND EQUIP REF CODE	(6) REMARKS CODE
			UNIT		DS	GS	DEPOT		
			C	O	F	H	D		
03010101040101	HYDRAULIC PUMP	Test	0.5						E
		Inspect	1.0						E
		Repair				4.0		2, 4, 7	
		Replace		6.0				1, 2, 4	
03010101040102	HYDRAULIC HAND PUMP	Inspect	1.0						E
		Repair					20.0		
		Replace		2.0				1, 2, 4	
03010101040103	HYDRAULIC WAY-VALVE	Repair				2.0		2, 4, 7	
		Replace		1.5				1, 2, 4	
030101010402	FEEDBACK UNIT	Inspect	1.0						E
		Repair				2.5		2, 4, 7	
		Replace			2.0			2, 4, 7	
0301010105	ALTERNATOR	Test			1.0			7, 14, 15	E
		Inspect	0.5						E
		Replace			2.0			7, 14, 15	
03010102	ENGINE EXHAUST SYSTEM	Clean		2.0				1, 3, 9	E
		Inspect		2.0				1, 3, 9	E
		Repair			6.0			3, 7, 9	
03010103	BILGE PUMP SYSTEM	Test		2.0				1	E
		Inspect	1.0						E
03010104	FIRE SUPPRESSION SYSTEM	Test					3.0		E
		Inspect	2.0				3.0		E

Table 1. MAC for Modular Causeway System. (MCS) (Continued)

(1) GROUP NO.	(2) COMPONENT/ASSEMBLY	(3) MAINTENANCE FUNCTION	(4) MAINTENANCE LEVEL					(5) TOOLS AND EQUIP REF CODE	(6) REMARKS CODE
			UNIT		DS	GS	DEPOT		
			C	O	F	H	D		
03010104	FIRE SUPPRESSION SYSTEM (CONT'D)	Repair					8.0		G
		Replace					24.0		G
03010105	FUEL SYSTEM	Test	1.0						E
		Inspect	1.0						E
		Repair			4.0			7	
		Replace			12.0			7	
0301010501	FUEL/WATER SEPARATOR	Clean	1.0						E
		Inspect	1.0						E
		Repair		2.0				1	
		Replace			4.0			7	
03010106	ELECTRICAL SYSTEM	Test			1.0			7, 14, 15	E
		Adjust			1.0			7, 14, 15	
		Repair			2.0			7, 14, 15	
		Replace			8.0			7, 14, 15	
03010107	EMERGENCY STEERING SYSTEM	Inspect	2.0						E
		Service	1.0						E
		Replace		4.0				1	
0301010701	STEERING UNIT	Inspect	0.5						E
		Replace		2.0				1	
0301010702	STEERING ADAPTOR	Inspect	0.5						E
		Replace		1.5				1	
03010108	HULL								

Table 1. MAC for Modular Causeway System. (MCS) (Continued)

(1) GROUP NO.	(2) COMPONENT/ASSEMBLY	(3) MAINTENANCE FUNCTION	(4) MAINTENANCE LEVEL				(5) TOOLS AND EQUIP REF CODE	(6) REMARKS CODE	
			UNIT		DS	GS			DEPOT
			C	O	F	H			D
0301010801	EXTERIOR	Clean		4.0				8, 9, 23, 24	E
		Inspect	1.0						E
		Service	1.5						E
		Repair		4.0				1, 16	
		Overhaul					24.0		
0301010802	INTERIOR	Clean					4.0		
		Inspect					2.0		
		Test					5.0	1, 25, 26	E
		Repair					6.0		
		Overhaul					50.0		
03010109	GUILLOTINE FITTINGS	Clean		1.0				8, 9, 23, 24	E
		Inspect	0.5						E
		Repair		3.0				1, 16	
		Replace		1.0				1	
03010110	HATCHES & HINGES	Clean	1.0						E
		Inspect	0.5					1	E
		Service	0.5						E
		Repair		2.0				1, 16	
		Replace		2.0				1	
03010111	FLEXORS	Inspect	0.5						E
		Replace	4.0						
030102	NON-POWERED MODULE								
03010201	HULL								

Table 1. MAC for Modular Causeway System. (MCS) (Continued)

(1) GROUP NO.	(2) COMPONENT/ASSEMBLY	(3) MAINTENANCE FUNCTION	(4) MAINTENANCE LEVEL					(5) TOOLS AND EQUIP REF CODE	(6) REMARKS CODE
			UNIT		DS	GS	DEPOT		
			C	O	F	H	D		
0301020101	EXTERIOR	Clean		4.0				8, 9, 23, 24	E
		Inspect	1.0						E
		Service	1.5						E
		Repair		4.0				1, 16	
		Overhaul					24.0		
0301020102	INTERIOR	Clean					4.0		
		Inspect					2.0		
		Test		8.0			5.0	1, 25, 26	E
		Repair					6.0		
		Overhaul					50.0		
03010202	GUILLOTINE FITTINGS	Clean		1.0				8, 9, 23, 24	E
		Inspect	0.5						E
		Repair		3.0				1, 16	
		Replace	1.0					1	
030103	OPERATORS CAB								
03010301	MIDDLE CONTROL PANEL	Test			2.0			7, 14, 15	E
		Inspect			2.0			7, 14, 15	E
		Repair			3.0			7, 14, 15	
		Replace			16.0			7, 14, 15	
03010302	LOWER CONTROL PANEL	Test			2.0			7, 14, 15	E
		Inspect			2.0			7, 14, 15	E
		Repair			3.0			7, 14, 15	
		Replace			16.0			7, 14, 15	

Table 1. MAC for Modular Causeway System. (MCS) (Continued)

(1) GROUP NO.	(2) COMPONENT/ASSEMBLY	(3) MAINTENANCE FUNCTION	(4) MAINTENANCE LEVEL					(5) TOOLS AND EQUIP REF CODE	(6) REMARKS CODE
			UNIT		DS	GS	DEPOT		
			C	O	F	H	D		
03010303	CIRCUIT BREAKER PANEL	Test			1.0			7, 14, 15	E
		Inspect			1.0			7, 14, 15	E
		Repair			2.0			7, 14, 15	
		Replace			12.0			7, 14, 15	
03010304	TERMINAL BOARD A-4	Test			1.0			7, 14, 15	E
		Inspect			1.0			7, 14, 15	E
		Repair			2.0			7, 14, 15	
		Replace			10.0			7, 14, 15	
03010305	SPOTLIGHT	Adjust		1.0				1	
		Replace		1.0				1	
03010306	DEFROSTER	Inspect	1.0						E
		Replace			4.0			7, 14, 15	
03010307	HEATER	Inspect		2.0				1	E
		Repair			4.0			7, 14, 15	
		Replace			6.0			7, 14, 15	
03010308	WINDSHIELD WIPER	Repair		1.0				1	
		Replace		2.0				1	
03010309	COMMUNICATIONS EQUIPMENT								
0301030901	VHF/FM HANDHELD TRANSCEIVER	Repair					8.0		
		Replace		1.0				1	

Table 1. MAC for Modular Causeway System. (MCS) (Continued)

(1) GROUP NO.	(2) COMPONENT/ASSEMBLY	(3) MAINTENANCE FUNCTION	(4) MAINTENANCE LEVEL					(5) TOOLS AND EQUIP REF CODE	(6) REMARKS CODE
			UNIT		DS	GS	DEPOT		
			C	O	F	H	D		
0301030902	AN/PSN-11 INTERFACE & SWITCHBOX	Repair					6.0		
		Replace			1.0			7, 14, 15	
0301030903	LOUDHAILER	Test	0.5						E
		Repair					8.0		
		Replace	0.5						
0301030904	SINGARS RADIO								H
0301030905	VHF/FM DSC TRANSCEIVER	Repair					12.0		
		Replace		1.0				1	
03010310	NAVIGATION EQUIPMENT	Test	0.5						E
		Inspect	1.0						E
0301031001	COMPASS	Inspect	2.0						E
		Replace		2.0				1	
		Calibrate		4.0				1	
0301031002	PLGR								I
03010311	MAST	Inspect	3.0						E
		Repair		3.0				1	
0301031101	NAVIGATION LIGHTS	Repair		1.0				1	
		Replace		1.0				1	
03010312	OPERATORS CAB ELECTRICAL SYSTEM	Test			4.0			7, 14, 15	E
		Inspect			4.0			7, 14, 15	E
		Repair				6.0		7, 14, 15	
		Replace			10.0			7, 14, 15	

Table 1. MAC for Modular Causeway System. (MCS) (Continued)

(1) GROUP NO.	(2) COMPONENT/ASSEMBLY	(3) MAINTENANCE FUNCTION	(4) MAINTENANCE LEVEL					(5) TOOLS AND EQUIP REF CODE	(6) REMARKS CODE
			UNIT		DS	GS	DEPOT		
			C	O	F	H	D		
030104	ANCHOR ASSEMBLY	Inspect	1.0						E
		Repair		1.0				1	
		Replace		1.0				1	
0302	CONTAINERS	Clean	1.0						E
		Inspect	2.0						E
		Repair			4.0			7	
		Replace					8.0		
0303	WINCH								AC
030301	WINCH DIESEL ENGINE								AD
030302	WINCH ASSEMBLY	Clean			8.0			7	E
		Test			4.0			7	E
		Inspect			4.0			7	E
		Service	4.0						
		Repair			4.0			7	
		Replace	3.0						

Table 1. MAC for Modular Causeway System. (MCS) (Continued)

(1) GROUP NO.	(2) COMPONENT/ASSEMBLY	(3) MAINTENANCE FUNCTION	(4) MAINTENANCE LEVEL					(5) TOOLS AND EQUIP REF CODE	(6) REMARKS CODE
			UNIT		DS	GS	DEPOT		
			C	O	F	H	D		
00	MODULAR CAUSEWAY SYSTEM (MCS)								
01	CAUSEWAY FERRY (CF)								
02	ROLL-ON/ROLL- OFF DISCHARGE FACILITY (RRDF)								
03	MODULAR WARPING TUG (WT)								
0301010101	DIESEL ENGINE	Inspect	4.0					E	
		Service	4.0	4.0				E	
		Repair				30.0	7, 27-218		
		Replace			120.0		7, 27-218		
		Overhaul				80.0			
030101010101	ENGINE BLOCK ASSEMBLY	Inspect	2.0					E, J	
		Repair				6.0	7, 27-52	J	
		Replace				120.0	7, 27-52	J	
030101010102	CYLINDER HEAD ASSEMBLY	Clean				5.0	7, 53-85	K	
		Inspect			6.0		7, 53-85	K	
		Repair				12.0	7, 53-85	K	
		Replace			8.0		7, 53-85	K	
030101010103	CRANKSHAFT ASSEMBLY	Repair			16.0		7, 86-106	L	
		Replace			24.0		7, 86-106	L	
030101010104	CAMSHAFT ASSEMBLY	Repair				12.0	7, 131-141		
		Replace				16.0	7, 131-141		

Table 1. MAC for Modular Causeway System. (MCS) (Continued)

(1) GROUP NO.	(2) COMPONENT/ASSEMBLY	(3) MAINTENANCE FUNCTION	(4) MAINTENANCE LEVEL					(5) TOOLS AND EQUIP REF CODE	(6) REMARKS CODE	
			UNIT		DS	GS	DEPOT			
			C	O	F	H	D			
030101010105	FLYWHEEL ASSEMBLY	Inspect			3.0			7, 107-112	M	
		Repair				3.0		7, 107-112	M	
		Replace			5.0			7, 107-112	M	
030101010106	PISTON ASSEMBLY	Clean				2.0		7, 113-130	N	
		Inspect				2.0		7, 113-130	N	
		Rebuild				4.5		7, 113-130	N	
		Replace				3.0		7, 113-130	N	
030101010107	ENGINE BALANCE	Inspect				6.0		7, 131-141	O	
		Adjust				3.0		7, 131-141	O	
		Repair				8.0		7, 131-141	O	
		Replace				8.0		7, 131-141	O	
030101010108	FUEL SYSTEM	Inspect	0.5						E, P	
03010101010801	FUEL PUMP	Inspect			1.0			7, 142-187	E	
		Repair			4.0			7, 142-187		
		Replace			2.0			7, 142-187		
03010101010802	PRIMING PUMP	Inspect		1.5				1, 142-187	E	
		Replace		2.0				1, 142-187		
030101010109	ELECTRIC GOVERNOR	Test		0.5					E	
		Adjust			1.0			7, 142-187		
		Repair					5.0			
		Replace		2.0				1, 142-187		
030101010110	AIR INTAKE SYSTEM	Clean		2.0				1, 188-195	E, Q	
		Inspect	0.5						E, Q	
		Replace		3.0				1, 188-195	Q	

Table 1. MAC for Modular Causeway System. (MCS) (Continued)

(1) GROUP NO.	(2) COMPONENT/ASSEMBLY	(3) MAINTENANCE FUNCTION	(4) MAINTENANCE LEVEL					(5) TOOLS AND EQUIP REF CODE	(6) REMARKS CODE
			UNIT		DS	GS	DEPOT		
			C	O	F	H	D		
03010101011001	BLOWER	Inspect			2.0	2.0		7, 188-195	E
		Adjust				4.0		7, 188-195	
		Repair				18.0		7, 188-195	
		Replace			8.0			7, 188-195	
03010101011002	TURBOCHARGER	Inspect			2.0			1, 188-195	E, R
		Repair					18.0		
		Replace			6.0			7, 188-195	
030101010111	LUBE OIL SYSTEM	Service	5.0	5.0					E, S
		Inspect	1.0						E, S
03010101011101	LUBE OIL PUMP	Inspect				3.0		7, 196-203	E
		Repair				4.0		7, 196-203	
		Replace				4.0		7, 196-203	
03010101011102	LUBE OIL COOLER	Clean			2.0			7	E
		Test			1.5			7, 25, 26	E
		Inspect			2.0			7	E
		Repair			4.0			7	
		Replace			2.0			7	
030101010112	FRESH WATER COOLING SYSTEM	Inspect	1.0						E, T
		Clean		1.0				1	
03010101011201	FRESH WATER PUMP	Inspect			2.5			7, 212-215	E
		Repair			6.0			7, 212-215	
		Replace			3.0			7, 212-215	

Table 1. MAC for Modular Causeway System. (MCS) (Continued)

(1) GROUP NO.	(2) COMPONENT/ASSEMBLY	(3) MAINTENANCE FUNCTION	(4) MAINTENANCE LEVEL					(5) TOOLS AND EQUIP REF CODE	(6) REMARKS CODE
			UNIT		DS	GS	DEPOT		
			C	O	F	H	D		
03010101011202	FRESH WATER COOLER	Clean			2.0			7	E
		Test			2.0			7, 25, 26	E
		Inspect			1.0			7	E
		Repair			4.0			7	
		Replace			3.0			7	
0301010101113	RAW WATER COOLING SYSTEM	Clean	1.0						E, U
		Inspect		2.0				1	E, U
03010101011301	RAW WATER PUMP	Inspect		2.0				1	E
		Repair			4.0			7, 212-215	
		Replace		2.5				1, 211-215	
0301010101114	ELECTRICAL SYSTEM	Test			4.0			7, 14, 15	E, V
		Inspect			2.0			7, 14, 15	E, V
		Repair			3.0			7, 14, 15	V
		Replace		4.0	16.0			1, 7, 14, 15	V
03010101011401	STARTER	Inspect	1.0						E
		Repair				6.0		7, 14, 15	
		Replace		3.0				1, 14, 15	
03010101011402	COLD PACK STARTER	Clean		1.0				1	E
		Inspect	0.5						E
		Adjust		1.0				1, 14, 15	
		Repair		2.5				1, 14, 15	
		Replace		3.0				1, 14, 15	

Table 1. MAC for Modular Causeway System. (MCS) (Continued)

(1) GROUP NO.	(2) COMPONENT/ASSEMBLY	(3) MAINTENANCE FUNCTION	(4) MAINTENANCE LEVEL					(5) TOOLS AND EQUIP REF CODE	(6) REMARKS CODE
			UNIT		DS	GS	DEPOT		
			C	O	F	H	D		
030101010115	OVER SPEED GOVERNOR	Test				1.0		7	E
		Adjust				1.5		7, 184-187	
		Repair				5.0		7, 184-187	
		Replace				4.0		7, 184-187	
030101010116	AUTO SHUTDOWN SYSTEM	Test		1.0					E
		Adjust			2.0			7, 14, 15	
		Repair				6.0		7, 14, 15	
		Replace		4.0			8.0	1	

Table 1. MAC for Modular Causeway System. (MCS) (Continued)

(1) GROUP NO.	(2) COMPONENT/ASSEMBLY	(3) MAINTENANCE FUNCTION	(4) MAINTENANCE LEVEL					(5) TOOLS AND EQUIP REF CODE	(6) REMARKS CODE
			UNIT		DS	GS	DEPOT		
			C	O	F	H	D		

Table 1. MAC for Modular Causeway System. (MCS) (Continued)

(1) GROUP NO.	(2) COMPONENT/ASSEMBLY	(3) MAINTENANCE FUNCTION	(4) MAINTENANCE LEVEL					(5) TOOLS AND EQUIP REF CODE	(6) REMARKS CODE
			UNIT		DS	GS	DEPOT		
			C	O	F	H	D		
00	MODULAR CAUSEWAY SYSTEM (MCS)								
01	CAUSEWAY FERRY (CF)								
02	ROLL-ON/ROLL- OFF DISCHARGE FACILITY (RRDF)								
03	MODULAR WARPING TUG (WT)								
0301010102	MARINE GEAR	Inspect	1.0					E	
		Align			2.0		7, 17		
		Service	1.0	4.0			1	E	
		Replace			28.0		4, 7, 17		
		Rebuild				25.0		W	
030101010201	OIL SYSTEM	Inspect	0.5					E, X	
		Repair		0.5			1, 11	X	
03010101020101	OIL COOLER	Clean	1.0					E	
		Inspect	1.0					E	
		Replace		4.0			1		
03010101020102	LINES & HOSES	Inspect	0.2					E	
		Repair		0.5			1		
		Replace		2.0			1		
03010101020103	OIL PUMP	Inspect	1.0					E	
		Replace			2.0		1, 3		
03010101020104	ELECTRIC CONTROL VALVE	Repair				8.0			
		Replace			6.0		7, 14, 15		

Table 1. MAC for Modular Causeway System. (MCS) (Continued)

(1) GROUP NO.	(2) COMPONENT/ASSEMBLY	(3) MAINTENANCE FUNCTION	(4) MAINTENANCE LEVEL					(5) TOOLS AND EQUIP REF CODE	(6) REMARKS CODE
			UNIT		DS	GS	DEPOT		
			C	O	F	H	D		
030101010202	GEAR MOUNTS	Inspect	0.5						E
		Replace			2.0			3, 7	
030101010203	COUPLING BLOCKS	Clean			1.0			7	E
		Inspect			1.0			7	E
		Replace			4.0			3, 7	
030101010204	OUTPUT FLANGE	Inspect	0.5						E
		Align			2.0			3, 7, 17	
		Replace			4.0			3, 7, 17	
030101010205	OUTPUT SEAL	Inspect			2.0			7	E
		Replace			2.0			3, 7	
030101010206	INPUT FLANGE (ENGINE CONNECTION)	Inspect	0.5						E

Table 1. MAC for Modular Causeway System. (MCS) (Continued)

(1) GROUP NO.	(2) COMPONENT/ASSEMBLY	(3) MAINTENANCE FUNCTION	(4) MAINTENANCE LEVEL					(5) TOOLS AND EQUIP REF CODE	(6) REMARKS CODE
			UNIT		DS	GS	DEPOT		
			C	O	F	H	D		
00	MODULAR CAUSEWAY SYSTEM (MCS)								
01	CAUSEWAY FERRY (CF)								
02	ROLL-ON/ROLL- OFF DISCHARGE FACILITY (RRDF)								
03	MODULAR WARPING TUG (WT)								
0301010103	TRANSFER CASE	Clean		2.0				1	E
		Service	1.0	4.0				1	E
		Overhaul				24.0			
		Rebuild					24.0	2, 7, 17	Y
		Replace			24.0			2, 7, 17	
030101010301	OIL SYSTEM	Inspect	1.0						E
		Repair		2.5				1	
03010101030101	OIL PUMP	Inspect	4.0						E
		Replace		2.5				1	
03010101030102	HOSES & FITTINGS	Inspect	0.2						E
		Replace		2.0				1	
03010101030103	OIL COOLER	Inspect	0.2						E
		Replace		3.5				1	
030101010302	GEAR SHAFT	Inspect				5.0		7	E
		Repair				8.0		3, 7, 17	
		Replace				7.0		3, 7, 17, 19	

Table 1. MAC for Modular Causeway System. (MCS) (Continued)

(1) GROUP NO.	(2) COMPONENT/ASSEMBLY	(3) MAINTENANCE FUNCTION	(4) MAINTENANCE LEVEL					(5) TOOLS AND EQUIP REF CODE	(6) REMARKS CODE
			UNIT		DS	GS	DEPOT		
			C	O	F	H	D		
03010101030201	UPPER SHAFT	Inspect				5.0		7	E
		Repair				8.0		3, 7, 17	
		Replace				7.0		3, 7, 17, 19	
0301010103020101	INPUT SEAL	Clean			2.0			7	E
		Inspect			2.0			7	E
		Replace			2.0			3, 7, 17, 19	
0301010103020102	OUTPUT SEAL	Clean			2.0			7	E
		Inspect			2.0			7	E
		Replace			2.0			3, 7, 17, 19	
03010101030202	INTERMEDIATE SHAFT	Inspect				2.5		7	E
		Repair				5.5		3, 7, 17	
		Replace				6.5		3, 7, 17, 19	
03010101030203	LOWER SHAFT	Inspect				4.0		7	E
		Repair				8.0		3, 7, 17	
		Replace				6.0		3, 7, 17, 19	
0301010103020301	INPUT SEAL	Clean			2.0			7	E
		Inspect			2.0			7	E
		Replace			2.0			3, 7, 17, 19	

Table 1. MAC for Modular Causeway System. (MCS) (Continued)

(1) GROUP NO.	(2) COMPONENT/ASSEMBLY	(3) MAINTENANCE FUNCTION	(4) MAINTENANCE LEVEL					(5) TOOLS AND EQUIP REF CODE	(6) REMARKS CODE
			UNIT		DS	GS	DEPOT		
			C	O	F	H	D		
00	MODULAR CAUSEWAY SYSTEM (MCS)								
01	CAUSEWAY FERRY (CF)								
02	ROLL-ON/ROLL- OFF DISCHARGE FACILITY (RRDF)								
04	FLOATING CAUSEWAY (FC)								
0401	INTERMEDIATE SECTION								
040101	NON-POWERED MODULE								
04010101	HULL								
0401010101	EXTERIOR	Clean		4.0				8, 9, 23, 24	E
		Inspect	1.0						E
		Service	1.5						E
		Repair		4.0				1, 16	
		Overhaul					24.0		
0401010102	INTERIOR	Clean					4.0		
		Inspect					2.0		
		Test		6.0			5.0	1, 25, 26	E
		Repair					6.0		
		Overhaul					50.0		
04010102	GUILLOTINE FITTINGS	Clean		1.0				8, 9, 23, 24	E
		Inspect	0.5						E
		Repair		3.0				1, 16	

Table 1. MAC for Modular Causeway System. (MCS) (Continued)

(1) GROUP NO.	(2) COMPONENT/ASSEMBLY	(3) MAINTENANCE FUNCTION	(4) MAINTENANCE LEVEL					(5) TOOLS AND EQUIP REF CODE	(6) REMARKS CODE
			UNIT		DS	GS	DEPOT		
			C	O	F	H	D		
04010102	GUILLOTINE FITTINGS (CONT'D)	Replace		1.0				1	
04010103	FLEXORS	Inspect	0.5						E
		Replace	4.0						
0402	COMBINATION BEACH-END SECTION								
040201	NON-POWERED MODULES								
04020101	HULL								
0402010101	EXTERIOR	Clean		4.0				8, 9, 23, 24	E
		Inspect	1.0						E
		Service	1.5						E
		Repair		4.0				1, 16	
		Overhaul					24.0		
0402010102	INTERIOR	Clean					4.0		
		Inspect					2.0		
		Test					5.0	1, 25, 26	E
		Repair					6.0		
		Overhaul					50.0		
04020102	GUILLOTINE FITTINGS	Clean		1.0				8, 9, 23, 24	E
		Inspect	0.5						E
		Repair		3.0				1, 16	
		Replace		1.0				1	
04020103	FLEXORS	Inspect	0.5						E
		Replace	4.0						

Table 1. MAC for Modular Causeway System. (MCS) (Continued)

(1) GROUP NO.	(2) COMPONENT/ASSEMBLY	(3) MAINTENANCE FUNCTION	(4) MAINTENANCE LEVEL					(5) TOOLS AND EQUIP REF CODE	(6) REMARKS CODE
			UNIT		DS	GS	DEPOT		
			C	O	F	H	D		
0403	GENERATOR SHELTER	Repair		4.0				1	
040301	ARMY TACTICAL QUIET GENERATOR (ATQG)								
040302	FUEL SYSTEM	Clean					1.0		E
		Inspect					1.0	7	
		Repair					5.0	1	
04030201	MANUAL FUEL PUMP	Clean		1.0				1	E
		Inspect	1.0	1.0				1	E
		Repair		2.0				1	
		Replace		2.0				1	
040303	LOUVERS	Clean		1.0				1	E
		Inspect	1.0						E
		Service		1.0					E
		Repair		3.0				1	
		Replace		4.0				1	
040304	ELECTRICAL SYSTEM	Test			2.0			7, 14, 15	E
		Repair		2.0	3.0			1, 7, 14, 15	
		Replace			5.0			7, 14, 15	
040305	FIRE SUPPRESSION SYSTEM	Test					4.0		E, G
		Inspect	1.0						E
		Repair		2.0			4.0	1, 14, 15	G
		Replace					40.0		G

Table 1. MAC for Modular Causeway System. (MCS) (Continued)

(1) GROUP NO.	(2) COMPONENT/ASSEMBLY	(3) MAINTENANCE FUNCTION	(4) MAINTENANCE LEVEL					(5) TOOLS AND EQUIP REF CODE	(6) REMARKS CODE
			UNIT		DS	GS	DEPOT		
			C	O	F	H	D		
0404	PERSONNEL SHELTER								
040401	HEAT PUMP	Clean		4.0				1	E
		Inspect		1.0				1	E
		Service			3.0			7, 21	E
		Repair			4.0			1, 7, 14, 15, 21	
		Rebuild				8.0		7, 14, 15, 21	
		Replace			8.0			7, 14, 15, 21	
040402	INCINOLET								AE
040403	ELECTRICAL SYSTEM	Inspect	2.0						E
		Repair		12.0	3.0			1, 7, 14, 15	
		Replace			12.0			7, 14, 15	
040404	COMMUNICATIONS EQUIPMENT								
04040401	VHF/FM HANDHELD TRANSCEIVER	Replace	1.0					1	
		Repair					8.0		
0405	LIGHT TOWER								
040501	ELECTRICAL SYSTEM	Test			1.0			10, 15	E
		Inspect			0.5			10, 15	E
		Repair			6.0			10, 15	

Table 1. MAC for Modular Causeway System. (MCS) (Continued)

(1) GROUP NO.	(2) COMPONENT/ASSEMBLY	(3) MAINTENANCE FUNCTION	(4) MAINTENANCE LEVEL					(5) TOOLS AND EQUIP REF CODE	(6) REMARKS CODE
			UNIT		DS	GS	DEPOT		
			C	O	F	H	D		
04050101	BATTERIES	Test			1.0			10, 13	E
		Inspect	0.5						E
		Replace		2.0				1	
04050102	OIL PRESSURE UNIT	Test			1.0			10	E
		Repair			1.0			10	
		Replace			1.5			10	
04050103	STARTING CIRCUIT	Repair			2.0			10, 15	
		Replace			3.0			10, 15	
04050104	ENGINE TEMPERATURE UNIT	Test			1.0			10, 18	E
		Repair			2.0			10, 18	
		Replace			2.5			10, 18	
04050105	HOUR METER UNIT	Repair			1.5			10	
		Replace			2.0			10	
04050106	SHUTDOWN CIRCUIT	Repair			2.0			10	
		Replace			4.0			10	
04050107	LAMP SYSTEM	Test	1.0						E
		Repair			2.0			10, 15	
		Replace			6.0			10, 15	
04050108	LAMP BALLAST SYSTEM	Test			0.5			10, 15	E
		Repair			2.0			10, 15	
		Replace			3.0			10, 15	
040502	GENERATOR	Clean		2.0				1	E
		Inspect					12.0		

Table 1. MAC for Modular Causeway System. (MCS) (Continued)

(1) GROUP NO.	(2) COMPONENT/ASSEMBLY	(3) MAINTENANCE FUNCTION	(4) MAINTENANCE LEVEL					(5) TOOLS AND EQUIP REF CODE	(6) REMARKS CODE	
			UNIT		DS	GS	DEPOT			
			C	O	F	H	D			
040502	GENERATOR (CONT'D)	Repair						18.0		
		Replace						24.0		
04050202	CONTROL PANEL	Test	1.0						E	
		Inspect	1.0						E	
		Repair			3.0				10, 15	
		Replace			4.5				10, 15	
04050205	DIESEL ENGINE	Service	4.0	2.0					1	E
		Adjust		3.0					1	
		Repair				16.0			10	
		Overhaul						16.0		
		Replace			16.0				10	
0405020501	ENGINE FUEL SYSTEM	Inspect	1.0							E
		Repair		4.0					1	
		Replace			8.0				10	
040502050101	FUEL PUMP	Inspect	1.0							E
		Repair				4.0			10	
		Replace			5.0				10	
040502050102	FUEL TANK	Clean	2.0							E
		Inspect	1.0							E
		Repair		2.0					1	
		Replace		2.0					1	
0405020502	ENGINE AIR SYSTEM	Inspect	1.0							E
		Repair		2.0					1	
		Replace		4.0					1	

Table 1. MAC for Modular Causeway System. (MCS) (Continued)

(1) GROUP NO.	(2) COMPONENT/ASSEMBLY	(3) MAINTENANCE FUNCTION	(4) MAINTENANCE LEVEL					(5) TOOLS AND EQUIP REF CODE	(6) REMARKS CODE
			UNIT		DS	GS	DEPOT		
			C	O	F	H	D		
0405020503	ENGINE COOLING SYSTEM	Inspect	1.0						E
		Repair		3.0				1	
		Replace		7.0				1, 10	
040502050301	FAN ASSEMBLY	Inspect	0.5						E
		Repair		1.5				1	
		Replace		2.0				1	
040502050302	COOLING WATER PUMP	Inspect						10	E
		Repair				4.0		10	
		Replace			5.0			10	
040502050303	RADIATOR	Clean	1.0						E
		Inspect		1.0				1	E
		Service	2.0	4.0				1	E
		Repair				4.0		10	
		Replace		2.0	3.0			1, 10	
		Inspect		1.0				1	E
0405020504	CYLINDER HEAD	Adjust					2.0		
		Repair					8.0		
		Replace					5.0		
		Repair					4.0		
0405020505	VIBRATION DAMPER	Replace					4.0		
		Replace					4.0		
0405020506	EXHAUST SYSTEM	Inspect	0.5						E
		Clean	1.5						E
		Repair			3.0			1, 16	
		Replace			5.0			1	

Table 1. MAC for Modular Causeway System. (MCS) (Continued)

(1) GROUP NO.	(2) COMPONENT/ASSEMBLY	(3) MAINTENANCE FUNCTION	(4) MAINTENANCE LEVEL					(5) TOOLS AND EQUIP REF CODE	(6) REMARKS CODE
			UNIT		DS	GS	DEPOT		
			C	O	F	H	D		
0405020507	CRANKSHAFT	Inspect					4.0		
		Repair					8.0		
		Replace					8.0		
0405020508	PISTON	Inspect					4.0		
		Repair					4.0		
		Replace					4.0		
04050206	RUNNING GEAR	Service		2.0				1	E
		Repair		2.0				1, 10	
		Replace		18.0				1	
0405020601	TIRES	Inspect	0.5						E
		Repair				1.0		10	
		Replace				1.0		10	
04050207	SUPPORT TOWER	Inspect	0.5						E
		Service	1.0						E
		Repair			2.0			10	
		Replace			6.0			10	
04050208	TOWER RAISING ASSEMBLY	Inspect	0.5						E
		Repair			1.0			10	
		Replace			3.0			10	
04050209	ENCLOSURE	Inspect	0.5						E
		Repair			2.0			10	
		Replace			6.0			10	
0406	OFFSHORE ANCHOR	Clean	1.0						E
		Inspect	1.0						E

Table 1. MAC for Modular Causeway System. (MCS) (Continued)

(1) GROUP NO.	(2) COMPONENT/ASSEMBLY	(3) MAINTENANCE FUNCTION	(4) MAINTENANCE LEVEL					(5) TOOLS AND EQUIP REF CODE	(6) REMARKS CODE
			UNIT		DS	GS	DEPOT		
			C	O	F	H	D		
0406	OFFSHORE ANCHOR (CONT'D)	Repair			4.0			7	
		Replace		2.0				1	
0407	ONSHORE ANCHOR	Clean	1.0						E
		Inspect	1.0						E
		Repair			4.0			7	
		Replace		2.0				1	
0408	CONTAINERS	Clean	1.0						E
		Inspect	2.0						E
		Repair			4.0			7	
		Replace					8.0		

Table 2. Remarks for Modular Causeway System. (MCS)

REMARKS CODE	REMARKS
A	See MAC Chart for Causeway Ferry Diesel Engine Group Number 0101010101.
B	See MAC Chart for Causeway Ferry Marine Gear Group Number 0101010102.
C	See MAC Chart for Causeway Ferry Marine Gear Group Number 0101010103.
D	All repairs to the pump-jet must be done at depot level due to lack of technical information provided by the manufacturer, Schottel of Germany.
E	Preventive Maintenance Checks and Services (PMCS).
F	Includes replacement of level sensors, pump and motor.
G	Most work needs to be done by an authorized manufacturer's technical representative.
H	Refer to Army Technical Manual TM 11-5820-890-10-8.
I	Refer to Army Technical Manual TM 11-5825-291-13.
J	Includes cylinder liner, crankcase, crankcase breather and engine mounts.
K	Includes valves, springs, rocker arm, push rods, etc.
L	Includes valves, main bearings, vibration damper and crankshaft pulley.

Table 2. Remarks for Modular Causeway System. (MCS) (Continued)

REMARKS CODE	REMARKS
M	Includes drive shaft flex coupling.
N	Includes rings, connecting rod and connecting rod bearings.
O	Includes gear train, camshaft, idler gear, idler gear bearing, crankshaft timing gear, blower drive gear, and front and rear accessory drive gears.
P	Includes fuel water separator, fuel lines, fuel filter/strainer, fuel cooler, fuel manifold, fuel injector, fuel injector tube and valves.
Q	Includes air shutdown housing and air box check valves.
R	Includes intercooler and after cooler.
S	Includes lube oil pump driving gear, lube oil pressure regulator, lube oil relief valves, lube oil filter by-pass valve, lube oil cooler by-pass valve, lube oil pan and lube oil ventilation system.
T	Includes fresh water manifold and thermostat.
U	Includes raw water duplex strainer.
V	Includes starting batteries.
W	Rebuild of the marine gear is a depot level function.
X	Includes oil filter screen, pressure gage, temperature gage, selector valve, oil pump drive, output seal and gear mounts.
Y	Rebuild of the transfer case is a depot level function.
Z	See MAC Chart for Modular Warping Tug Diesel Engine Group Number 0301010101.
AA	See MAC Chart for Modular Warping Tug Marine Gear Group Number 0301010102.
AB	See MAC Chart for Modular Warping Tug Transfer Case Group Number 0301010103.
AC	Refer to Army Technical Manual TM 55-3950-204-14 & P.
AD	Refer to Army Technical Manual TM 5-2815-258-24.
AE	Refer to Army Technical Manual TM 55-1925-257-14&P.

Table 3. Tools and Test Equipment for Modular Causeway System. (MCS)

TOOL OR TEST EQUIPMENT REF CODE	MAINTENANCE LEVEL	NOMENCLATURE	NATIONAL STOCK NUMBER	TOOL NUMBER
1	O	General Mechanics Rail and Marine Tool Kit	5180-00-629-9783	
2	O	Torque Wrench, 30-150 in. lbs 3/8 in. Drive	5120-00-230-6380	
3	O	Torque Wrench, 30-150 ft lbs 1/2 in. Drive	5120-00-247-2540	
4	D	Torque Wrench, 100-500 ft lbs	5120-00-542-5577	
5	D	Pinch Pry Bar 60	5120-00-224-1384	
6	D	Hammer, Hand, (sledge hammer) 10 lb	5120-00-251-4489	
7	D	General Mechanics Tool Kit	5180-00-177-7033	
8	O	Hammer, Hand, Scaling	5120-00-224-4111	
9	O	Wire Brush	7920-00-291-5815	
10	D	Automotive Tool Kit	5810-00-177-7033	
11	O	Wrench, Strap	5120-00-776-1840	
12	D	Wrench, Monkey	5120-00-277-3120	
13	D	Electrolyte Solution Battery Tester	6630-00-171-5126	
14	O	Fuse Puller and Tester	5120-00-319-3295	
15	O	Multimeter	6625-00-171-5126	
16	O	Welder Tool Kit	5180-00-754-0661	
17	D	Dial Indicator	5120-00-402-9619	
18	D	Thermometer, Test	6685-00-056-3109	
19	G	Wheel Puller		
20	D	Pliers, Snap Ring		
21	D	Tool Kit, Compressor	5180-01-188-5075	
22		Megger	6625-01-015-1451	
23	O	Power Washer		
24	O	Scraper, Long Handle		

Table 3. Tools and Test Equipment for Modular Causeway System. (MCS) (Continued)

TOOL OR TEST EQUIPMENT REF CODE	MAINTENANCE LEVEL	NOMENCLATURE	NATIONAL STOCK NUMBER	TOOL NUMBER
25	O	Air Tester		
26	O	Air Compressor		
27	D	Adaptor (1 5/8 in. Dia plugs) (Cylinder Block)		J21850
28	D	Aftercooler Adaptor Cup Plug Installer		J28711
29	D	Aftercooler Adaptor Plug Remover and Installer		J25275
30	D	Aftercooler Cup Plug Installer (2 1/2 in. Dia)		J24597
31	D	Alignment Tool		J21799
32	D	Block Assembly Wrench Set		J25451-B
33	D	Block Thread Repair Kit		J29513
34	D	Cup Plug Installer (1 in. Dia)		J33420
35	D	Cylinder Block Air Box Plugging Tool		J29571
36	D	Cylinder Block Line Boring Tool		J29005
37	D	Cylinder Block Tap		J25384
38	D	Cylinder Diameter Checking Gage		J5347-B
39	D	Cylinder Hone Set (2 1/2 in. to 5 3/4 in.)		J5902-01
40	D	Dial Bore Gage Master Setting Fixture		J23059-01
41	D	Dial Indicator Set		J22273-01
42	D	Diesel Engine Parts Dolly		J6387
43	D	Handle		J7079-02
44	D	Loctite "Chisel" Gasket Remover		PT7275
45	D	Master Ring Gage for Block Bore		J24564

Table 3. Tools and Test Equipment for Modular Causeway System. (MCS) (Continued)

TOOL OR TEST EQUIPMENT REF CODE	MAINTENANCE LEVEL	NOMENCLATURE	NATIONAL STOCK NUMBER	TOOL NUMBER
46	D	Overhaul Stand (6V and 8V engines)		J29109
47	D	Overhaul Stand (12V and 16V engines)		J9384-04
48	D	Overhaul Stand Adaptor (6V and 8V engines)		J33850
49	D	Overhaul Stand Adaptor (12V and 16V engines)		J8650
50	D	Pipe Plug Remover/Installer (1/8 in. Dia)		J34650
51	D	Special Plug Remover (dry cylinder block)		J21995-01
52	D	Special Plug Remover		J23019
53	D	Load Cell Kit, Cam Follower Roller Fixture (Cylinder Head)		J33421-25
54	D	Cam Follower Service Fixture		J33421-A
55	D	Cylinder Head Bolt Hole Cleanout Tap		J25384
56	D	Cylinder Head Guide Studs (set of two)		J24748
57	D	Cylinder Head Holding Plate Set		J3087-01
58	D	Cylinder Head Lifting Fixture		J22062-01
59	D	Engine Barring Tool		J22582
60	D	Feeler Gage Set (.0015 in. to .015 in.)		J3172
61	D	Feeler Stock (.0015 in.)		J23185
62	D	Fuel Line Nut Wrench		J8932B
63	D	Injector Fuel Hole Brush		J8152
64	D	Pressure Checking Tool		J28454
65	D	Push Rod Remover (set of three)		J3092-01
66	D	Slide Hammer		J2619-01

Table 3. Tools and Test Equipment for Modular Causeway System. (MCS) (Continued)

TOOL OR TEST EQUIPMENT REF CODE	MAINTENANCE LEVEL	NOMENCLATURE	NATIONAL STOCK NUMBER	TOOL NUMBER
67	D	Spring Tester		J22738-02
68	D	Valve Bridge Holding Fixture		J21772
69	D	Valve Bridge Gage Remover (broken)		J7453
70	D	Valve Bridge Guide Remover Set		J7091-01
71	D	Valve Bridge Guide Installer		J7482
72	D	Valve Guide Cleaner		J5437
73	D	Valve Guide Installer (machined)		J21520
74	D	Valve Guide Remover		J6569-A
75	D	Valve Seat Dial Gage		J8165-2
76	D	Valve Guide Oil Seal Installer		J35373
77	D	Valve Seat Grinder (Model VIP)		J7040-A
78	D	Valve Seat Grinder		J8165-1A
79	D	Valve Seat Grinder Adaptor Set		J24566
80	D	Valve Seat Insert Installer		J24357
81	D	Valve Seat Insert Remover Assembly		J23479-492
82	D	Valve Seat Insert Remover Collet		J23479-33
83	D	Valve Spring Checking Gage		J25076-B
84	D	Valve Spring Compressor		J7455-A
85	D	Water Nozzle Installer (intermediate)		J24857-A
86	D	Front Oil Seal Installer (6V and 8V) (Crankshaft)		J9783
87	D	Rear Oil Seal Installer (std and ovs seals)		J21112-B
88	D	Handle		J3154-A
89	D	Guide Studs (c/s with dowels)		J9727-2
90	D	Guide Studs (c/s without dowels)		J9727-5

Table 3. Tools and Test Equipment for Modular Causeway System. (MCS) (Continued)

TOOL OR TEST EQUIPMENT REF CODE	MAINTENANCE LEVEL	NOMENCLATURE	NATIONAL STOCK NUMBER	TOOL NUMBER
91	D	Expander (std seal)		J4239
92	D	Handle		J8092
93	D	Guide Studs		J25002
94	D	Expander (ovs seal, no handle or guide studs)		J8682
95	D	Sleeve Installer (ovs seal)		J21983
96	D	Installer		J9727-A
97	D	Handle		J3154-1A
98	D	Expander (std seal, no handle)		J22425-A
99	D	Expander (ovs seal, no handle or guide studs)		J4195-01
100	D	Installer (ovs seal)		J4194-01
101	D	Dial Indicator Set		J5959-01
102	D	Engine Barring Tool		J22582
103	D	Flywheel Housing Alignment Studs		J1927-01
104	D	Micrometer Ball Attachment		J4757
105	D	Torque Wrench Adaptor (12V and 16V engines)		J22898-A
106	D	Universal Bar Type Puller		J24420-B
107	D	Flywheel Lifting Fixture (Flywheel)		J25026
108	D	Flywheel Lifting Tool		J6361-01
109	D	Oil Seal Removing and Replacing Tool Set		J3154-04
110	D	Slide Hammer Set		J5901-01
111	D	Flywheel Housing Aligning Studs (set of four) (Flywheel Housing)		J1927-01
112	D	Flywheel Housing Concentricity Gage Set		J9734-C

Table 3. Tools and Test Equipment for Modular Causeway System. (MCS) (Continued)

TOOL OR TEST EQUIPMENT REF CODE	MAINTENANCE LEVEL	NOMENCLATURE	NATIONAL STOCK NUMBER	TOOL NUMBER
113	D	Connecting Rod Holding Fixture (Piston, Connecting Rod and Cylinder Liner)		J7632
114	D	Cylinder Liner Master Ring Gage		J24564
115	D	Cylinder Hone Set (2½ in. to 5¾ in. range)		J5902-01
116	D	Cylinder Liner Hold-Down Tool		J24565-02
117	D	Cylinder Liner Remover Set		J24563-A
118	D	Dial Bore Gage Setting Fixture		J23059-01
119	D	Dial Indicator Set		J24898
120	D	Feeler Gage Set		J3172
121	D	Micrometer Ball Attachment		J4757
122	D	Piston Crown Identification Gage		J25397-A
123	D	Piston Pin Alignment Tool		J24285
124	D	Piston Pin Retainer Installer		J23762-A
125	D	Piston Pin Retainer Leak Detector (plastic)		J23987-B
126	D	Piston Pin Retainer Leak Detector (all metal)		J35134
127	D	Piston Ring Compressor		J24227
128	D	Piston Ring Remover Installer		J8128
129	D	Piston to Liner Feeler Gage Set		J5438-01
130	D	Seal Ring Compressor		J24226
131	D	Accessory Drive Hub Oil Seal Aligning Tool (Camshaft)		J21166
132	D	Alternator Drive Step-Up Gear Aligning Gage		J29893
133	D	Balance Weight Cover Oil Seal Installer		J9791
134	D	Camshaft Gear Puller		J1902-B

Table 3. Tools and Test Equipment for Modular Causeway System. (MCS) (Continued)

TOOL OR TEST EQUIPMENT REF CODE	MAINTENANCE LEVEL	NOMENCLATURE	NATIONAL STOCK NUMBER	TOOL NUMBER
135	D	Camshaft Gear Puller Adaptor Plate Set		J6202-01
136	D	Camshaft and Oil Pump Gear Installer		J1903
137	D	Dial Indicator and Attachment Set		J5959-01
138	D	Puller Adaptor		J7932
139	D	Slide Hammer Set		J6471-02
140	D	Spring Scale		J8129
141	D	Universal Bar Type Puller		J24420-B
142	D	Pullers (Fuel & Governors)		J6270-1
143	D	Oil Seal Remover and Installer		J6270-3
144	D	Buffing Wheel (brass wire)		J7944
145	D	Fuel Pipe Socket		J8932-B
146	D	Fuel System Primer		J5956
147	D	Injector Auxiliary Tester		J22640-A
148	D	Injector Body Reamer		J21089
149	D	Injector Calibrator		J22410
150	D	Injector Carbon Remover Set		J9418
151	D	Injector Holding Fixture		J22396
152	D	Injector Nut Seal Ring Installer		J29197
153	D	Injector Service Tool Set		J23435-C
154	D	Body Brush		J8152
155	D	Nut Socket Wrench		J4983-01
156	D	Rack Hole Brush		J8150
157	D	Spray Hole Cleaner Vice		J4298-1
158	D	Spray Tip Carbon Remover (high sack)		J9464-01

Table 3. Tools and Test Equipment for Modular Causeway System. (MCS) (Continued)

TOOL OR TEST EQUIPMENT REF CODE	MAINTENANCE LEVEL	NOMENCLATURE	NATIONAL STOCK NUMBER	TOOL NUMBER
159	D	Spray Tip Carbon Remover (low sack)		J24838
160	D	Spray Tip Driver and Brushing Cleaner		J129101
161	D	Wire Sharpening Stone		J8170
162	D	Injector Tag Remover and Installer		J24767
163	D	Injector Test Oil (5, 10, 30 and 55 GAL)		J26400
164	D	Injector Tester		J23010-B
165	D	DDEC Injector Adaptor Kit		J23010-500
166	D	Lapping Block Set		J22090-A
167	D	Master Injector Calibrating Kit		J35369
168	D	Needle Valve Lift Gage		J9462-02
169	D	Polishing Compound		J23038
170	D	Polishing Stick Set		J22964
171	D	Spray Tip Cleaning Wire (.007 in. Dia holes)		J21462-01
172	D	Spray Tip Flow Gage		J25600-B
173	D	Field Modification Kit		J25600-103
174	D	Spring Tester		J29196
175	D	Tip Conical. Gage and Rack Freeness Tester		J29584
176	D	Cylinder Head Holding Plate Set		J3087-01
177	D	Cylinder Liner Depth Gage		J22273-01
178	D	Injector Protrusion Gage		J25521
179	D	Injector Tube Service Tool Set		J22525-B
180	D	Injector Tube Swaging Tool		J28611-A
181	D	Fuel Pump Tool Set		J1508-E

Table 3. Tools and Test Equipment for Modular Causeway System. (MCS) (Continued)

TOOL OR TEST EQUIPMENT REF CODE	MAINTENANCE LEVEL	NOMENCLATURE	NATIONAL STOCK NUMBER	TOOL NUMBER
182	D	Fuel Pump Wrench		J4242
183	D	Control Link Operating Lever Bearing Remover and Installer		J8985
184	D	Governor Cover Bearing Installer		J21068
185	D	Governor Cover Bearing Remover and Installer		J21967-01
186	D	High Speed Spring Retainer and Installer		J5345-12
187	D	Governor Weight Shaft Retaining Ring Installer		J36840
188	D	Blower Alignment Tool (Air System)		J33001
189	D	Blower Clearance Feeler Set		J1698-02
190	D	Blower Service Tool Set		J6270-G
191	D	Installer, Lip Type Oil Seal/Water Sleeve		J35787-A
192	D	Dial Indicator Set (magnetic base)		J7872
193	D	Turbocharger Inlet Shield		J26554-A
194	D	Adaptor Cup Plug Installer		J28711
195	D	Adaptor Plug Remover and Installer		J25275
196	D	Bar Type Gear Puller (Lubrication System)		J24420
197	D	Oil Pump Drive Gear Installer (16V)		J9380
198	D	Oil Pump Drive Shaft Gear Installer (6V and 8V)		J22397
199	D	Oil Pump Driven Gear Installer (16V)		J9381
200	D	Oil Pump Driven Shaft Gear Installer (6V and 8V)		J22398

Table 3. Tools and Test Equipment for Modular Causeway System. (MCS) (Continued)

TOOL OR TEST EQUIPMENT REF CODE	MAINTENANCE LEVEL	NOMENCLATURE	NATIONAL STOCK NUMBER	TOOL NUMBER
201	D	Oil Pump Driving Gear Installer (6V and 8V)		J22285
202	D	Spring Tester (1-125 lbs)		J29196
203	D	Strap Wrench (spin-on filter)		J24783
204	D	Cooling System Radiator Cap Pressure Tester (Cooling System)		J24460-01
205	D	Fingers, Fan Hub Nut Socket (16V)		J6534-8
206	D	Handle		J7079-2
207	D	Oil Seal Installer		J8501
208	D	Pliers		J4646
209	D	Puller		J24420-A
210	D	Socket, Fan Hub Nut (16V)		J22556-2
211	D	Thermostat Seal Installer		J8550
212	D	Water Pump Bearing and Gear Installer		J25257
213	D	Water Pump Impeller/Gear Slip Torque Tool		J33765
214	D	Water Pump Seal Remover Set		J22150-B
215	D	Water Pump Impeller Slip Checking Fixture		J34034
216	D	Slide Hammer (Electrical Equipment)		J23907-1
217	D	Tachometer Drive Alignment Tool Set		J23068
218	D	Tachometer Drive Shaft Remover		J5901-3
219	O	Coveralls, Eye Protection, Respirator, Gloves (Zodiac Boat Hull)		
220	O	Grease Pencil Or Chalk		

Table 3. Tools and Test Equipment for Modular Causeway System. (MCS) (Continued)

TOOL OR TEST EQUIPMENT REF CODE	MAINTENANCE LEVEL	NOMENCLATURE	NATIONAL STOCK NUMBER	TOOL NUMBER
221	O	Saber Saw With Metal Cutting Blades		
222	D	Grinder or Disc Sander w/ Coarse Medium Grit		
223	O	Measuring Tape		
224	D	Scissors, Shears		
225	O	Cardboard, Kraft Paper		
226	D	Disposable Containers, Mixing Sticks		
227	D	Disposable Brushes, Putty Knife		
228	D	Polyethylene Sheet		
229	D	Heavy Cardboard, Thin Plywood, Sheet Metal		
230	D	Acetone		

**UNIT, DIRECT SUPPORT AND GENERAL SUPPORT MAINTENANCE
CAUSEWAY FERRY
ENGINE
EXPENDABLE AND DURABLE ITEMS LIST (EDIL)**

INTRODUCTION

Scope

This work package lists expendable and durable items to help you will need to operate and maintain the Causeway Ferry. This list is for information only and is not authority to requisition the listed items. These items are authorized to you by CTA 50-970, Expendable/Durable Items (Except Medical, Class V Repair Parts, and Heraldic Items), or CTA 8-100, Army Medical Department Expendable/Durable Items.

Explanation of Columns in the Expendable/Durable Items List

Column (1) - Item Number. This number is assigned to the entry in the listing and is referenced in the narrative instructions to identify the item (e.g., Use antiseize compound (Item 3, WP 0187 00)).

Column (2) - Level. This column identifies the lowest level of maintenance that requires the listed item. (C = Operator/Crew, O = Unit./AVUM, F = Direct Support/AVIM, H = General Support, D = Depot)

Column (3) - National Stock Number (NSN). This is the NSN assigned to the item which you can use to requisition it.

Column (4) - Item Name, Description, Commercial and Government Entity Code (CAGEC), and Part Number (PN). This column provides the other information you need to identify the item.

Column (5) - Unit of Measure (U/M). This code shows the physical measurement or count of an item, such as gallon, dozen, gross, etc.

EXPENDABLE AND DURABLE ITEMS LIST

Table 1. Expendable and Durable Items List. (EDIL)

(1) ITEM NUMBER	(2) LEVEL	(3) NATIONAL STOCK NUMBER	(4) ITEM NAME, DESCRIPTION, CAGEC, PART NUMBER	(5) U/M
1	F	8040-01-147-6849	Adhesive, 3M super weather-strip and gasket rubber adhesive (34360) 08008	TU
2	H	8040-01-250-3969	Adhesive, general purpose, medium strength thread locker (05972) 242	BT
3	D	8040-00-995-0590	Adhesive, general purpose silicone rubber (71984) SILISTIC 732 RTV	TU
4	D	5850-01-141-5192	Adhesive, Spray, 16 oz can adhesive spray (82866) 411	CN
5	H	6850-00-181-7933	Antifreeze, blue green with boiling point of 300° F. (06946) MIL-A-46153	GL

Table 1. Expendable and Durable Items List. (EDIL) (Continued)

(1) ITEM NUMBER	(2) LEVEL	(3) NATIONAL STOCK NUMBER	(4) ITEM NAME, DESCRIPTION, CAGEC, PART NUMBER	(5) U/M
6	O	8030-00-251-3980	Antiseize Compound, 1 lb can thread compound (81349) MIL-A-907	LB
7	H	4240-01-436-8860	Boots, Disposable (1JA49) WPL346	PR
8	O	6850-01-431-9025	Cleaner, Type II, 50 lb container (81349) MIL-C-29602	LB
9	O	6850-00-598-7328	Cleaning Compound, Engine Cooling System, oxalic acid and aluminum chloride with conditioner (81349) MIL-C-10597	KT
10	H		Cleaning Compound, powdered detergent HA-777	LB
11	F	5350-00-192-5047	Cloth, Abrasive, aluminum oxide, 80 grit, 11 X 9 in (80204) ANSI B74.18	PG
12	H	5330-00-246-0330	Cloth, Abrasive, aluminum oxide, 320 grit, 11 X 9 in. (80204) ANSI B74.18	PG
13	O	7920-00-044-9281	Cloth, Cleaning, lint free cloth (58536) A-A-59323	BX
14	O	2815-01-454-2017	Cleaning Kit, Air Filter, 1 qt, 10 oz oil and cotton (69502) DDF9000	KT
15	O	4020-01-011-0665	Cord, Fibrous, nylon outer covering and polyester core (80256) 316705	RO
16	O	8030-00-062-6950	Corrosion Preventative Compound, Class 1, Grade 1 preservative (81349)MIL-C-16173	QT
17	H	5510-00-237-8254	Dowel, Wood, general purpose wood rod 0.125 in. X 3 ft (81348) NN-D-570	FT
18	H	9140-01-412-1311	Fuel, Diesel, winter grade DF1 low sulfur (81348) VV-F-800	GL
19	H	9140-01-413-7511	Fuel, Diesel, summer grade DF2 low sulfur (81348) VV-F-800	GL
20	F	9150-01-197-7689	Grease Automotive and Artillery, 6.5 lb can, conforms to PPP-C-96, Type V, Class 2 (81399) M-10924-A	CN

Table 1. Expendable and Durable Items List. (EDIL) (Continued)

(1) ITEM NUMBER	(2) LEVEL	(3) NATIONAL STOCK NUMBER	(4) ITEM NAME, DESCRIPTION, CAGEC, PART NUMBER	(5) U/M
21	F	9150-01-095-5512	Grease, Ball and Roller Bearing, lithium soap, temperature range -35° – 325° F (-54° – 163° C) (73219) L0189.001	CN
22	D	9150-00-235-5555	Grease, General Purpose, mineral oil and molybdenum disulfide, low evaporation, corrosive and salt water resistive (81349) MIL-G-23549	CN
23	O	5510-00-220-6146	Lumber, Softwood, Dimension, 2 in. X 4 in. X 6 ft min. (81348) MM-L-751	EA
24	O	5510-00-220-6178	Lumber, Softwood, Dimension, 4 in. X 4 in. X 8 ft min. (81348) MM-L-751	EA
25	O	9150-00-189-6727	Oil, Lubricating, Engine, 10W grade antiwear, antifoam, corrosion resistive (81349) M2104-1-10W	QT
26	O	9150-00-186-6681	Oil, Lubricating, Engine, 30W grade antiwear, antifoam, corrosion resistive (81349) M2104-1-30W	QT
27	H	9150-00-189-6730	Oil, Lubricating, Engine, 40W grade antiwear, antifoam, corrosion resistive (81349) MILL2104	QT
28	O	7920-00-205-1711	Rags, Wiping, mixed color, unbleached cotton (80244) 7920-00-205-1711	LB
29	F	8030-00-204-9149	Sealing Compound, white plastic paste tetrafluoroethylene pipe sealant (05972) 592-41	TU
30	O	8030-01-299-1762	Sealing Compound, superflex ultra-blue no leak silicone gasket (05972) 8730	TU
31	H	8030-00-252-3391	Sealing Compound, 11 oz tube, gasoline, grease, oil, water and hydrocarbon resistant (62377) FORMAGASKET2	TU
32	O	4235-01-416-8456	Spill Clean-up Kit, Hazardous Material, kit contains: two rolls 50 ft X 5 in. folded sorbent, 30 sorbent pads 17 in. X 19 in., three temporary disposal bags with ties, one 20 gal drum with lid and plastic closure ring. (50378) P-SKFL31	KT
33	F	5975-00-156-3253	Straps, Tiedown, plastic 13.350 in. Comp A, Type 1 (56501) TY-28M	HD

Table 1. Expendable and Durable Items List. (EDIL) (Continued)

(1) ITEM NUMBER	(2) LEVEL	(3) NATIONAL STOCK NUMBER	(4) ITEM NAME, DESCRIPTION, CAGEC, PART NUMBER	(5) U/M
34	O	8030-00-889-3535	Tape, Antiseizing, polytetrafluoroethylen unfused, white, 1/2 in. wide X 260 in. long, 0.0035 in. thick (58536) A-A-58092	RO
35	O	5970-01-290-1623	Tape, Electrical, black linerless rubber splicing tape (75037) 130C1INX30FT	RO
36	H	7510-00-266-6710	Tape, Pressure Sensitive Adhesive, 60 yard roll (81346) ASTM D-6123	RO
37	F	4020-00-926-1386	Twine, Fibrous, vegetable fiber MIL-T-73, Type N, Class 3 (80063) SCC30639-1	EA
38	O	6550-01-310-1677	Water, Reagent Distilled, four 1 gallon per package (07TA6) C4350-1A	PK
39	F	5510-00-268-3476	Wedge, Wood, butt thickness 1.5 in. tapered to feathered edge X 3 in. wide (80064) S8800-461043	EA
40	H	9505-00-770-8514	Wire, Nonelectrical, corrosion resisting steel, 0.032 in. diameter (96906) MS20995C32	RO

**UNIT, DIRECT SUPPORT AND GENERAL SUPPORT MAINTENANCE
CAUSEWAY FERRY
DIESEL ENGINE
TOOL IDENTIFICATION LIST**

INTRODUCTION**Scope**

This work package lists all common tools and supplements and special tool/fixtures needed to maintain the Causeway Ferry Diesel Engine.

Explanation of Columns in the Tool Identification List

Column (1) - Item Number. This number is assigned to the entry in the list and is referenced in the initial setup to identify the item (e.g., Respirator. (Item 4, WP 0107 00)).

Column (2) - Item Name. This column lists the item by noun nomenclature and descriptive features (e.g. Gage, belt tension).

Column (3) - National Stock Number. This is the National Stock Number (NSN) assigned to the item; use it to requisition the item.

Column (4) - Part Number/CAGEC. Indicates the primary number used by the manufacturer (individual, company, firm, corporation, or Government activity) which controls design and characteristics of the item by means of its engineering drawings, specifications, standards, and inspection requirements to identify an item or range of items. The manufacturer's Commercial and Government Entity Code (CAGEC) is also included.

Column (5) - Reference. This column identifies the authorizing supply catalog or RPSTL for items listed in this work package.

TOOL IDENTIFICATION LIST**Table 1. Tool Identification List. (TIL)**

(1) ITEM NO.	(2) ITEM NAME	(3) NATIONAL STOCK NUMBER	(4) PART NUMBER/ CAGEC	(5) REFERENCE
1	Adaptor kit, valve seat grinder	5120-01-232-0004	J24566 (33287)	
2	Adaptor, engine stand	4910-00-146-9624	J33850 (33287)	
3	Adaptor, mechanical puller	5120-00-733-8890	J7932 (33287)	
4	Adaptor, remover (seal ring carrier)	5120-01-048-1387	J6270-2 (33287)	
5	Alignment stud, flywheel housing	5120-00-629-9781	J1927-01 (33287)	
6	Alignment tool, blower drive	5120-01-158-3391	J33001(33287)	
7	Alignment tool, piston pin	5120-01-232-0007	J24285 (33287)	
8	Apron, utility	8415-00-082-6108	A-A-55063 (58536)	SC 4910-95-A68
9	Blaster, uneven surface (glass bead)	4940-00-103-6818	248802 (62555)	

Table 1. Tool Identification List. (TIL) (Continued)

(1) ITEM NO.	(2) ITEM NAME	(3) NATIONAL STOCK NUMBER	(4) PART NUMBER/ CAGEC	(5) REFERENCE
10	Body, cylinder hone	5130-01-227-1686	J5902-1 (33287)	
11	Body, puller	5120-01-188-2949	J1902-1 (33287)	
12	Bolt, eye	5306-01-372-9275	2BH944 (45152)	
13	Bolt, machine	5306-00-637-9344	11028A (1ML14)	
14	Bolt, machine	5306-01-365-1180	MBEU147255 (30003)	
15	Bolt, machine	5306-00-206-5351	NAS428K4-16 (80205)	
16	Bolt, machine	5306-00-028-4282	STD395 (80254)	
17	Bracket, mounting	5340-01-158-3984	J24565-02 (33287)	
18	Brush, bottle and buret	7920-01-091-1759	3-640 (19631)	
19	Brush, cleaning, valve guide	5120-00-766-2141	J-5437 (33287)	
20	Brush, stencil (soft bristle)	7520-00-223-8000	A-A-2903 (58536)	SC 4910-95-A72
21	Brush, wire, scratch	7920-00-291-5815	7920002915815 (83421)	SC 4910-95-A72
22	Caliper set, micrometer, outside	5120-00-554-7134	S436CRLZ (57163)	
23	Caliper, micrometer, inside	5120-00-221-1918	52-275-001 (1E258)	
24	Caps, vice jaw	5120-00-221-1506	A-A-2938 (58536)	SC 4910-95-A72
25	Checker, valve spring	5120-00-166-5169	J25076-B (33287)	
26	Collet, valve seat insert remover	5120-01-048-1379	J-23479-33 (33287)	
27	Compressor unit, reciprocating, power drive	4310-00-861-9820	MILC13874 (81349)	SC 4940-95-A64
28	Compressor, ring	4910-01-158-3974	J24227 (33287)	
29	Compressor, valve spring	5120-01-297-2397	J7455A (33287)	
30	Counter, electronic, digital readout	6625-01-376-9207	UC10A (0N6H2)	
31	Crowfoot attachment, socket wrench (3/8 in. sqdr)	5120-01-335-1150	FCO14A (55719)	
32	Degreaser (tank, cleaning)	4940-00-449-6689	MILD12491 (81349)	SC 4910-95-A72
33	Drill set, twist	5133-00-293-0983	DB129B (55719)	SC 4920-95-A72

Table 1. Tool Identification List. (TIL) (Continued)

(1) ITEM NO.	(2) ITEM NAME	(3) NATIONAL STOCK NUMBER	(4) PART NUMBER/ CAGEC	(5) REFERENCE
34	Drilling machine, upright	3413-00-294-9573	MILD13930 (81349)	
35	Elbow, pipe to tube	4730-00-842-3162	8924182 (72582)	
36	Evacuation unit (FLOCS)		E13053 (34712)	
37	Expander, oil seal	5120-00-336-0445	J4239 (33287)	
38	Fixture, lifting, cylinder	4910-00-456-7620	J22062-01 (33287)	
39	Fixture, test, head	4910-01-158-3985	J28454 (33287)	
40	Gage set, piston	5210-08-116-1631	J5438-01 (33287)	
41	Gage set, thickness	5210-01-245-9564	J1698-02 (33287)	
42	Gage, cylinder	5210-00-023-4798	J22273-01 (33287)	
43	Gage, cylinder	5210-01-174-4498	J24898 (33287)	
44	Gage, cylinder	5210-01-070-4543	J5347-B (33287)	
45	Gage, Dial, Valve Seat	4910-00-779-7103	9320 (00256)	
46	Gage, groove	5220-01-028-1109	J24599 (33287)	
47	Gage, injector rack	5210-00-538-8465	J23190 (33287)	
48	Gage, injector, timing	5210-01-160-2614	J26888 (33287)	
49	Gage, master ring	5210-01-232-0003	J24564 (33287)	
50	Gage, strain (indicator dial)		696 (57163)	
51	Generator, function, electronic, test	6625-01-467-5583	FG3B (0N6H2)	
52	Gloves, chemical	8415-00-266-8677	ZZ-G-381 (81348)	
53	Gloves, men's and women's (leather palm)	8415-00-634-4658	37G2940 (90142)	
54	Goggles, industrial (chipping, chemical)	4240-00-052-3776	ANSI Z87.1 (80204)	
55	Goggles, plate, welders	4240-01-016-6707	86550 (77852)	
56	Grinder, valve seat	4910-00-254-5048	J7040A (33287)	
57	Grinding machine, valve face	4910-00-540-4679	K403CM (35472)	SC 4910-95-A68
58	Guide stud set	5120-01-048-2155	J25002 (33287)	
59	Hammer, hand (dead blow)	5120-01-065-9037	57-533 (61711)	

Table 1. Tool Identification List. (TIL) (Continued)

(1) ITEM NO.	(2) ITEM NAME	(3) NATIONAL STOCK NUMBER	(4) PART NUMBER/ CAGEC	(5) REFERENCE
60	Hammer, hand (lead)	5120-00-241-3583	GGG-H-33 (81348)	
61	Hammer, hand, (plastic)	5120-00-357-6077	GGG-H-33 (81348)	
62	Handle, driver	5120-00-808-5082	J-3154-1A (33287)	
63	Handle, Driver	5120-00-677-2259	J8092 (33287)	
64	Heater	2825-00-240-6028	200005-1-REV- LATEST (60306)	
65	Hoist, chain	3950-00-965-0098	MILH904 (81349)	SC 4910-95-A68
66	Hose assembly, non-metallic (air hose)	4720-00-356-8577	V2130D (63986)	SC 4910-95-A72
67	Indicator, dial	5210-00-402-9619	J7872 (33287)	
68	Insert bearing and bushing	5120-01-165-6810	J6270-13 (33287)	
69	Insert, gear	5120-01-033-8902	J25257 (33287)	
70	Installer and remover, inlet adaptor	5120-01-048-2180	J25275 (33287)	
71	Installer and remover, plug	5120-01-130-8864	J-23019 (33287)	
72	Installer, piston pin retainer	5120-00-127-7757	J23762-A (33287)	
73	Installer, seal	4910-01-299-9289	J35787-2 (33287)	
74	Installer, valve guide	5120-00-999-8617	J-21520 (33287)	
75	Installer, water nozzle	5120-01-048-3119	J-24857-A (33287)	
76	Kit, diesel engine, diagnosis	4910-00-075-4889	J9531-C (33287)	
77	Lifting sling, flywheel	5120-01-132-5447	J-25026 (33287)	
78	Liner puller		LP 92 (55752)	
79	Magnetic clamp, indi	4910-01-158-3976	J7872-2 (33287)	
80	Magnifier	6650-00-256-9059	8635918 (19200)	
81	Mallet, rubber	5120-00-293-3399	69-490 (03914)	
82	Manometer, vertical tube	6685-01-128-5662	J-29021 (33287)	
83	Mittens, heat protective	8415-00-266-8840	HH-M-391 (81348)	
84	Multimeter	6625-01-265-6000	27/FM W/ACCE (89536)	

Table 1. Tool Identification List. (TIL) (Continued)

(1) ITEM NO.	(2) ITEM NAME	(3) NATIONAL STOCK NUMBER	(4) PART NUMBER/ CAGEC	(5) REFERENCE
85	Oiler, hand	4930-00-274-5713	A-A-50477B (58536)	SC 4910-95-A72
86	Pail, utility	7240-01-252-7075	4486T4 (39428)	
87	Pan, drain	4910-00-287-2944	MILP45819 (81349)	SC 4910-95-A68
88	Pilot set, oversize	5120-00-070-1021	J6270-28 (33287)	
89	Pilot, blower shaft	5120-00-070-1017	J6270-5 (33287)	
90	Pin, drift	5120-00-168-5251	N-TD2186A1 (82796)	
91	Pin, straight, headless	5315-01-162-3630	J24748 (33287)	
92	Plate kit, gear bear	5180-01-167-4285	2SK900 (45152)	
93	Pliers, retaining ring	5120-00-293-0049	B248360 (19207)	
94	Pliers, retaining ring	5120-00-288-9717	2104893 (19207)	
95	Pliers, retaining ring	5120-01-024-6182	J4646 (72582)	
96	Power supply assembly	6130-01-242-8813	WP-707 (41266)	
97	Press, arbor hand operated	3444-00-449-7295	A-A-51194 (80244)	
98	Protector, hearing	4240-00-759-3290	19A (71483)	
99	Puller kit, universal (crossbar)	5180-00-423-1596	GGG-P-781 (81348)	
100	Puller kit, universal (slide hammer)	5180-00-999-4053	J 24420-C (33287)	
101	Puller, blower gear	5120-00-070-1014	J6270-31 (33287)	
102	Reamer, hand	5110-00-294-4606	J5286-9C (33287)	
103	Reconditioning tool, piston ring groove	5110-00-554-7286	RC 500 (55719)	SC 4910-95-A68
104	Remover and replace (piston ring pliers)	5120-00-494-1846	J-8128 (33287)	
105	Remover, blower bearings and adaptor	5120-01-048-1388	J6270-3 (33287)	
106	Remover, valve guide	5120-00-733-8880	J-6569-A (33287)	
107	Remover, valve seat insert	5120-01-352-5531	J23479-492 (33287)	
108	Replacing tool, engine valve seat insert	5120-01-048-3118	J24357 (33287)	
109	Respirator, air filtering	4240-00-883-6519	85556 (55799)	
110	Rule, steel, machinist's	5210-00-273-1960	607R36IN (57163)	

Table 1. Tool Identification List. (TIL) (Continued)

(1) ITEM NO.	(2) ITEM NAME	(3) NATIONAL STOCK NUMBER	(4) PART NUMBER/ CAGEC	(5) REFERENCE
111	Scale, tension	4910-00-779-6832	J8129 (33287)	
112	Screwdriver attachment set, socket wrench (¼ in. sqdr and 3/8 in. sqdr)	5120-01-477-9873	208EFTABY (55719)	
113	Seal installer, FLYW	4910-01-176-4230	J21112-B (33287)	
114	Setting master, dial bore gage	5210-00-367-7378	J23059-01 (33287)	
115	Shackle, ½ in. 2 ton		1019472 (75535)	
116	Shackle, ¾ in. 4.75 ton		1019515 (75535)	
117	Sheet, Metal (Bar Stock)	9535-00-052-9659	QQA225-8 (81348)	
118	Sling, 5300 lbs, 6 ft (green)		ENG0X6FT (3AJ34)	
119	Spacer installer, to	4910-01-296-9936	J35787-A (72582)	
120	Stand, maintenance, automotive engine	4910-00-529-8387	MILS45004 (81349)	
121	Stone, abrasive, cylinder hone	5130-00-937-7280	J5902-14 (33287)	
122	Test kit, radiator-r	4910-00-728-8227	J24460-01 (33287)	
123	Tester, spring	4940-01-138-8259	J-22738-02 (50941)	
124	Tester, spring resiliency	6635-01-170-5001	J29196 (33287)	
125	Tester, vacuum gage	6685-01-061-4253	J-23987-B (33287)	
126	Testing kit, cylinder block pressure, service	5180-01-252-9800	2SK737 (45152)	
127	Thermometer, self-indicating	6685-00-174-6235	MILT12625 (81349)	
128	Tongs, blacksmiths	5120-00-223-8246	203 (79416)	
129	Tool kit, fuel pump	5180-00-219-8407	J-1508-E (33287)	
130	Tool Kit, general mechanic's	5180-00-177-7033	SC5180-90-CL-N26 (50980)	SC 5180-90-N26
131	Tool kit, general mechanic's (rail and marine)	5180-00-629-9783	SC5180-90-CL-N55 (50980)	
132	Torch set, cutting and welding	3433-00-294-6743	A-A-55826 (58536)	SC 4910-95-A72
133	Vise, machinist's	5120-00-293-1439	504M20 (79416)	
134	Wrench set, socket (¾ in. sqdr)	5120-00-204-1999	B107.1 (05047)	
135	Wrench set, socket (3/8 in. sqdr)	5120-00-322-6231	51200017510 (19207)	

Table 1. Tool Identification List. (TIL) (Continued)

(1) ITEM NO.	(2) ITEM NAME	(3) NATIONAL STOCK NUMBER	(4) PART NUMBER/ CAGEC	(5) REFERENCE
136	Wrench, pipe (10 in.)	5120-00-277-1485	5120002771485 (83421)	SC 4910-95-A72
137	Wrench, strap	5120-01-160-8863	3397929 (15434)	
138	Wrench, torque (0-175 ft lbs) (½ in. sqdr)	5120-01-396-5751	1753LDF (08194)	
139	Wrench, torque (100-600 ft lbs) (¾ in. sqdr)	5120-00-221-7983	SW130-301 (10001)	
140	Wrench, torque (0-75 in. lbs) (¼ in. sqdr)	5120-01-112-9532	B107.14M TY1CLCST1 (80204)	
141	Wrench, torque (10-250 in. lbs) (3/8 in. sqdr)	5120-01-356-0743	J24405 (33287)	
142	Wrench, torque (150-750 in. lbs) (3/8 in. sqdr)	5120-01-374-1931	GGG-W-2843 (81348)	

INDEX

Subject

WP Sequence No.– Page No.

A

Alphabetical Index.....INDEX - 1

Above Normal Reading On Engine Coolant Temperature Gage,
 Troubleshooting Procedures 0017 00 001

Aftercooler, Replacement 0155 00 001

Air Box

 Covers, Removal and Installation 0035 00 001

 Drain Hose, Replacement 0037 00 001

 Drains, Removal, Cleaning, Inspection and Installation 0036 00 001

 Testing 0034 00 001

Air Inlet Collector Assembly

 Removal and Installation 0104 00 001

 Repair 0105 00 001

Air Intake Housing, Removal, Cleaning, Inspection, Repair and Installation 0103 00 001

Alignment 0033 00 001

Auto Shutdown System

 Emergency Stop Solenoid, Replacement 0176 00 001

 Fuel Oil Pressure Switch, Replacement 0179 00 001

 High Water Temperature Switch, Replacement 0177 00 001

 Low Oil Pressure Switch, Replacement 0178 00 001

B

Below Normal Reading On Engine Coolant Temperature Gage,
 Troubleshooting Procedures 0018 00 001

Blower

 Assembly, Repair 0111 00 001

 Bypass Valve, Replacement 0108 00 001

 Drive Assembly, Removal and Installation 0112 00 001

 Drive Assembly, Repair 0113 00 001

 Drive Shaft and Spring Assembly, Replacement 0109 00 001

 Removal and Installation 0110 00 001

C

Camshaft

 Accessory Drive Pulley, Replacement 0066 00 001

 Balance Weight, Replacement 0065 00 001

 Bearings, Replacement 0062 00 001

 Gears, Replacement 0064 00 001

 Idle Gear, Repair 0068 00 001

 Idle Gears, Removal and Installation 0067 00 001

 Replacement 0062 00 001

 Vibration Damper, Replacement 0063 00 001

Cold Pac Starting Aid, Replacement 0171 00 001

Cold Start Temperature Switch, Replacement 0172 00 001

Crankcase Breather Limiter Assembly, Replacement 0106 00 001

Crankcase Ventilation Breather Pipe, Replacement 0107 00 001

Crankshaft and Stabilizer, Removal, Cleaning, Inspection, Repair and Installation 0060 00 001

INDEX (CONT'D)

Subject

WP Sequence No. – Page No.

C (CONT'D)

Crankshaft Rear Oil Seal, Replacement	0061 00 001
Cylinder Head	
Cam Follower, Replacement	0052 00 001
Crankcase Breather, Cleaning	0044 00 001
Exhaust Valves, Adjustment	0045 00 001
Fuel Manifold, Removal, Cleaning, Inspection and Installation	0050 00 001
Poppet Valve Rocker Arm, Removal, Cleaning, Inspection and Installation	0048 00 001
Poppet Valve Rocker Arm, Repair	0049 00 001
Poppet Valve Rocker Arm Covers, Replacement	0043 00 001
Push Rod, Replacement	0053 00 001
Removal and Installation	0046 00 001
Repair	0051 00 001
Valve Guide Bridge, Replacement	0057 00 001
Valve Guides and Seals, Replacement	0058 00 001
Cylinder Head Exhaust Valve	
Guides, Cleaning and Inspection	0059 00 001
Removal and Installation	0054 00 001
Repair	0055 00 001
Seat Inserts, Replacement	0056 00 001

D

Description and Data	
Equipment Characteristics, Capabilities and Features	0002 00 001
Equipment Data	0004 00 001
Location and Description of Major Components	0003 00 001

E

Electrical Generating System	
Fully Charged Battery and High Charging Rate, Troubleshooting Procedures	0022 00 001
Low Battery and Low or No Charging Rate, Troubleshooting Procedures	0021 00 001
Electrical System	
Hour Meter Mounting Bracket, Replacement	0168 00 001
Hour Meter, Replacement	0167 00 001
Normal Stop Push Button Mounting Bracket, Replacement	0166 00 001
Normal Stop Push Button, Replacement	0165 00 001
Electrical Wiring, Repair	0181 00 001
Electronic Governor	
Actuator Stays At Minimum Position When Power Is Applied, Troubleshooting Procedures	0023 00 001
Actuator, Replacement	0098 00 001
Controller, Replacement and Adjustment	0099 00 001
Drive Assembly, Removal and Installation	0101 00 001
Drive Assembly, Repair	0102 00 001
Goes To Full Stroke When DC Power Is Applied and Engine Is Not Operating, Troubleshooting Procedures	0024 00 001

INDEX (CONT'D)

Subject

WP Sequence No.– Page No.

E (CONT'D)

Electronic Governor (Cont'd)	
Magnetic Pick-Up, Replacement	0100 00 001
Rod Assembly, Replacement	0097 00 001
Engine	
Block, Repair	0042 00 001
Does Not Start In Cold Temperatures, Troubleshooting Procedures	0009 00 001
Fails To Stop When Emergency Stop Is Activated, Troubleshooting Procedures ..	0019 00 001
Lacks Power, Troubleshooting Procedures	0012 00 001
Starts With Difficulty and Run Rough, Troubleshooting Procedures	0010 00 001
Turns Over But Will Not Start, Troubleshooting Procedures	0008 00 001
Will Not Turn Over, Troubleshooting Procedures	0007 00 001
Equipment Characteristics, Capabilities and Features, Description and Data	0002 00 001
Equipment Data, Description and Data	0004 00 001
Excessive Reading On Oil Pressure Gage, Troubleshooting Procedures	0016 00 001
Exhaust Manifold, Replacement	0163 00 001
Expendable and Durable Items List (EDIL)	0187 00 001

F

Flywheel	
Housing, Replacement	0071 00 001
Removal and Installation	0069 00 001
Repair	0070 00 001
Forward Lifting Bracket, Replacement	0139 00 001
Fresh Water Cooling System	
Bypass Hoses, Replacement	0148 00 001
Coolant Hoses, Replacement	0149 00 001
Filter Element, Replacement	0140 00 001
Filter Head Cover Mounting Bracket, Replacement	0142 00 001
Filter Head Cover, Replacement	0141 00 001
Flush	0134 00 001
Heat Exchanger, Removal and Installation	0138 00 001
Heat Exchanger, Removal, Cleaning, Inspection and Installation	0137 00 001
Port Thermostat Housing, Replacement	0145 00 001
Port Water Outlet Manifold	
Replacement	0150 00 001
Pressure Testing	0136 00 001
Pump Drive Gear, Replacement	0153 00 001
Pump, Removal and Installation	0152 00 001
Pump, Repair	0154 00 001
Servicing	0133 00 001
Starboard Thermostat Housing, Replacement.....	0144 00 001
Starboard Water Outlet Manifold, Replacement	0151 00 001
Thermostat	
Replacement	0143 00 001
Thermostat, Testing	0146 00 001
Fresh Water Heat Exchanger, Cleaning	0135 00 001
Fresh Water Temperature Sending Unit, Replacement	0147 00 001

INDEX (CONT'D)

Subject

WP Sequence No. – Page No.

F (CONT'D)

Front Balance Weight Cover	
Removal and Installation	0076 00 001
Repair	0075 00 001
Front Cylinder Block Plate	
Removal and Installation	0040 00 001
Repair	0041 00 001
Fuel Adaptor (Block), Replacement	0085 00 001
Fuel Cooler	
Mounting Bracket, Replacement	0082 00 001
Replacement	0081 00 001
Zinc Anode Plug, Replacement	0156 00 001
Fuel Filter	
Adaptor, Replacement	0083 00 001
Cartridge, Replacement	0079 00 001
Mounting Bracket, Replacement	0084 00 001
Fuel Hoses and Tubes, Replacement	0080 00 001
Fuel Ignition Modulator Assembly	
Adjustment	0090 00 001
Removal and Installation	0088 00 001
Repair	0089 00 001
Fuel Injector	
Assembly, Removal, Cleaning, Inspection and Installation	0091 00 001
Control Tube and Lever Assembly, Removal and Installation	0086 00 001
Control Tube and Lever Assembly, Repair	0087 00 001
Rack Control Lever, Adjustment	0093 00 001
Timing, Adjustment	0092 00 001
Fuel Priming Pump, Replacement	0096 00 001
Fuel Pump	
Removal and Installation	0094 00 001
Repair	0095 00 001
Fuel System	
Priming	0077 00 001
Testing	0078 00 001

G

General Information	0001 00 001
---------------------------	-------------

H

Hazardous Material Warning Icons	c
Heat Exchanger Zinc Anode Plug, Replacement	0158 00 001
High Oil Consumption, Troubleshooting Procedures	0014 00 001
How To Use This Manual	vii

L

List of Effective Pages/Work Packages	A
Location and Description of Major Components, Description and Data	0003 00 001
Low Reading On Oil Pressure Gage, Troubleshooting Procedures	0015 00 001

INDEX (CONT'D)

Subject

WP Sequence No. – Page No.

L (CONT'D)

Lube Oil

Cooler Bypass Valve, Removal, Cleaning, Inspection and Installation	0129 00 001
Cooler, Removal, Cleaning, Inspection and Installation	0128 00 001
Level Dipstick Tube Assembly, Replacement	0130 00 001
Pan, Replacement	0127 00 001
Pressure Regulator Valve, Removal and Installation	0123 00 001
Pressure Regulator Valve, Repair	0124 00 001
Pressure Relief Valve, Removal and Installation	0125 00 001
Pressure Relief Valve, Repair	0126 00 001
Pressure Sending Unit, Replacement	0131 00 001
Pump Inlet Screen, Removal, Cleaning, Inspection and Installation	0121 00 001
Pump, Removal and Installation	0119 00 001
Pump, Repair	0120 00 001
System Crankcase, Pressure Testing	0116 00 001
System Crankcase, Servicing	0115 00 001
System Distribution Components, Removal, Cleaning, Inspection and Installation	0122 00 001
System Hoses, Replacement	0118 00 001
System Turbocharger Flanged Oil Tube To Engine Oil Hose, Replacement	0117 00 001
Temperature Switch, Replacement	0132 00 001

M

Maintenance Allocation Chart (MAC)	0186 00 001
Maintenance Allocation Chart (MAC), Introduction	0185 00 001
Maintenance Stand, Installation and Removal	0032 00 001
Marine Gear	
Cooler Zinc Anode Plug, Replacement	0157 00 001
Oil Cooler Mounting Bracket, Replacement	0164 00 001
Mounts, Inspection	0029 00 001

N

Noisy Operation or Vibration In Turbocharger, Troubleshooting Procedures	0020 00 001
Not Receiving Fuel From Tank, Troubleshooting Procedures	0013 00 001

O

Overspeed Governor, Replacement and Adjustment	0175 00 001
--	-------------

P

Pipe Nipples, Elbows, Tees, Adaptors and Plugs, Replacement	0180 00 001
Piston	
Assembly, Removal and Replacement	0072 00 001
Cylinder Liner, Rebuild	0073 00 001
Liner Assembly, Removal and Replacement	0072 00 001
Liner, Rebuild.....	0073 00 001
Preventive Maintenance Checks and Services (PMCS)	
Lubrication Procedures	0027 00 001
Procedures Introduction	0026 00 001

INDEX (CONT'D)

Subject

WP Sequence No. – Page No.

R

Raw Water Pump
 Removal and Installation 0160 00 001
 Repair 0161 00 001
 Seal, Replacement 0162 00 001
 Zinc Anode Plug, Replacement 0159 00 001

Rear Cylinder Block Plate
 Removal and Installation 0038 00 001
 Repair 0039 00 001

Rear Lifting Brackets, Replacement 0047 00 001

References 0184 00 001

Removal and Installation 0031 00 001

S

Safety Warning Icons b

Service Upon Receipt 0025 00 001

Starter Relay, Replacement 0169 00 001

Starting Motor, Replacement 0170 00 001

Sudden Loss of Power, Troubleshooting Procedures 0011 00 001

T

Table of Contents i

Tachometer Drive, Replacement 0174 00 001

Tachometer Sending Unit, Replacement 0173 00 001

Testing 0030 00 001

Theory of Operation 0005 00 001

Tool Identification List (TIL) 0188 00 001

Torque Limits Work Package 0182 00 001

Troubleshooting Procedures
 Above Normal Reading On Engine Coolant Temperature Gage 0017 00 001
 Below Normal Reading On Engine Coolant Temperature Gage 0018 00 001

Electrical Generating System
 Fully Charged Battery and High Charging Rate 0022 00 001
 Low Battery and Low or No Charging Rate 0021 00 001

Electronic Governor
 Actuator Stays At Minimum Position When Power Is Applied 0023 00 001
 Goes To Full Stroke When DC Power Is Applied and Engine Is
 Not Operating 0024 00 001

Engine Does Not Start In Cold Temperatures 0009 00 001

Engine Fails To Stop When Emergency Stop Is Activated 0019 00 001

Engine Lacks Power 0012 00 001

Engine Starts With Difficulty and Run Rough 0010 00 001

Engine Turns Over But Will Not Start 0008 00 001

Engine Will Not Turn Over 0007 00 001

Excessive Reading On Oil Pressure Gage 0016 00 001

High Oil Consumption 0014 00 001

Index 0006 00 001

INDEX (CONT'D)

Subject

WP Sequence No. – Page No.

T (CONT'D)

Troubleshooting Procedures (Cont'd)

Low Reading On Oil Pressure Gage	0015 00 001
Noisy Operation or Vibration In Turbocharger	0020 00 001
Not Receiving Fuel From Tank	0013 00 001
Sudden Loss of Power	0011 00 001
Tune-Up	0028 00 001
Turbocharger, Replacement	0114 00 001

V

Vibration Damper, Replacement	0074 00 001
-------------------------------------	-------------

W

Warning Summary	a
Wiring Diagrams	0183 00 001
Wire Diagram Fold Outs	FO-1

LEGEND:

- A1 ENGINE & COMPONENTS.
- A1B1 ENGINE STARTER
- A2 THRUSTER & COMPONENTS
- A2B1 THRUSTER STEERING POSITION SYNCHRO
- A2JB2 THRUSTER JUNCTION BOX
- A2JB1 HYDRAULIC CONTROL
- A2S2 THRUSTER GEAR BOX OIL LEVEL SW
- A3 PROPULSION MODULE JUNCTION BOX
- A4 ENGINE JUNCTION BOX & E STOP SW
- A5 BILGE PUMP CONTROL PANEL
- A6 CIRCUIT BREAKER PANEL
- A7 SINGLE BILGE PUMP CONTROL PANEL
- A8 VENT FAN RELAY ENCLOSURE
- A9 THRUSTER DIR/ AUX. BATT. JUNCTION BOX ASSY. ENCLOSURE

- B1 VENT FAN MOTOR (B1)
- BT BATTERY
- G1 ALTERNATOR
- JB1 JUNCTION BOX FOR #1 BILGE PUMP (B2)
- JB2 JUNCTION BOX FOR #3 BILGE PUMP (B4)
- JB3 NATO RECEPTACLE
- JB5 JUNCTION BOX FOR #5 BILGE PUMP (B6)
- JB6 JUNCTION BOX FOR #6 BILGE PUMP (B7)
- JB8 JUNCTION BOX FOR #4 BILGE PUMP (B5)
- L1 COLD START SOLENOID
- L2/L3 CLUTCH ENGAGE FORWARD/ENGAGE BACKFLUSH SOLENOIDS

- S2 CO2 PRESSURE SWITCH
- S8 FIRE THERMAL DETECTOR LOCATED AFT
- S9 FIRE THERMAL DETECTOR LOCATED MIDDLE
- VR1 REGULATOR FOR ALTERNATOR

LEGEND NOTES: 1. ENGINE COMPONENTS INCLUDE ACTUATOR FOR SPEED GOVERNOR, ELECTRONIC OVERSPEED SWITCH, PRESSURE SWITCHES, TEMP & PRESS SENDING UNITS ETC. SEE SCHEMATIC E26554. THESE ARE WIRED TO ENGINE IN HARNESS KMB-1
 2. HYD CONTROL BOX CONNECTS TO STEERING SOLENOIDS.
 3. THIS LEGEND LISTS ONLY THOSE COMPONENTS CONNECTED IN PROPULSION MODULE & DOES NOT ADDRESS COMPONENTS WIRED ON SUBASSEMBLIES.

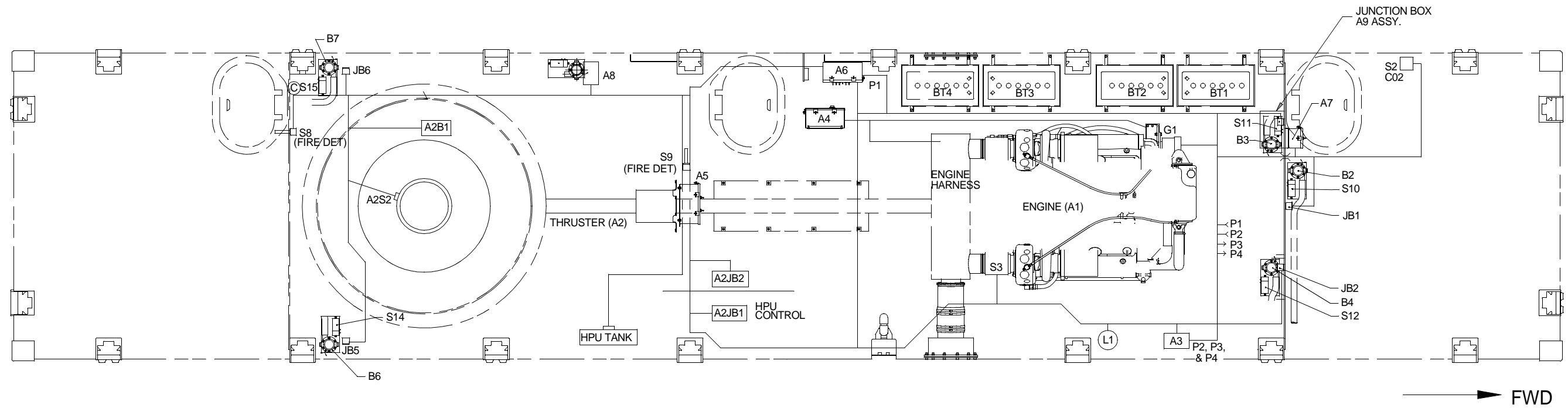

Figure 1. MCS Propulsion Module Electrical Assembly Wiring Diagram (Sheet 1).

CABLE LEGEND

CABLE ID.	DESCRIPTION
P24	24VDC DISTRIBUTION
KEH	CLUTCH CONTROL
KMB	ENGINE CONTROL
KL	STEERING CONTROL
CFR	FIRE CO2 RELEASE SWITCH
CBP	BILGE PUMP AND INDICATION CONTROL
CF	FIRE/FLOOD DETECTORS
CFD	BILGE PUMPS/SWITCHES
HPU	HYD. POWER UNIT
VF	VENT FAN
SWE	CABLE/HARNESS "SUPPLIED WITH EQUIP"
P1	24V PLUG/CABLE ASSEMBLY
P2	PLUG/CABLE ASSEMBLY
P3	PLUG/SHIELDED CABLE ASSEMBLY
P4	PLUG/CABLE ASSEMBLY
P5	PLUG/CABLE ASSEMBLY

DESIGNATION	TYPE	DESCRIPTION	O.D.
D3	LSDHOF-3	2/C 16 AWG	.425
D4	LSDHOF-4	2/C 14 AWG	.460
D9	LSDNW-9	2/C 10 AWG	.545
D30	LSDHOF-30	2/C 5 AWG	.960
D50	LSDNW-50	2/C 3 AWG	.910
T3	LSTHOF-3	3/C 16 AWG	.450
T4	LSTHOF-4	3/C 14 AWG	.480
T9	LSTNW-9	3/C 10 AWG	.625
F4	LSFNW-4	4/C 14 AWG	.513
F9	LSFNW-9	4/C 10 AWG	.630
4SJ20	LS4SJ-20	4/C 20 AWG	.320
2SJ18	LS2SJ-18	2/C 18 AWG	.310
I/O	I/O CABLE	1/C I/O AWG	.910

DESIGNATION	TYPE	DESCRIPTION	O.D.
-	-	-	-
M19	LSMHOF-19	19/C 16 AWG	.705
M14	LSMHOF-14	14/C 16 AWG	.635
M37	LSMHOF-37	37/C 16 AWG	.925
3SJ18	LS3SJ18	3/C SHLD 18 AWG	.325
3SU-7	LS3SU-7	7 SHLD TRIADS	.910
SWE	VARIOUS	SUPPLIED WITH EQUIP.	-
S06	2S0-6	2/C 6 AWG	.825
BATT	5JBX-1011-02P	1/C 1/O BK	.491
BATT	5JBX-1011-03P	1/C 1/O RED	.491

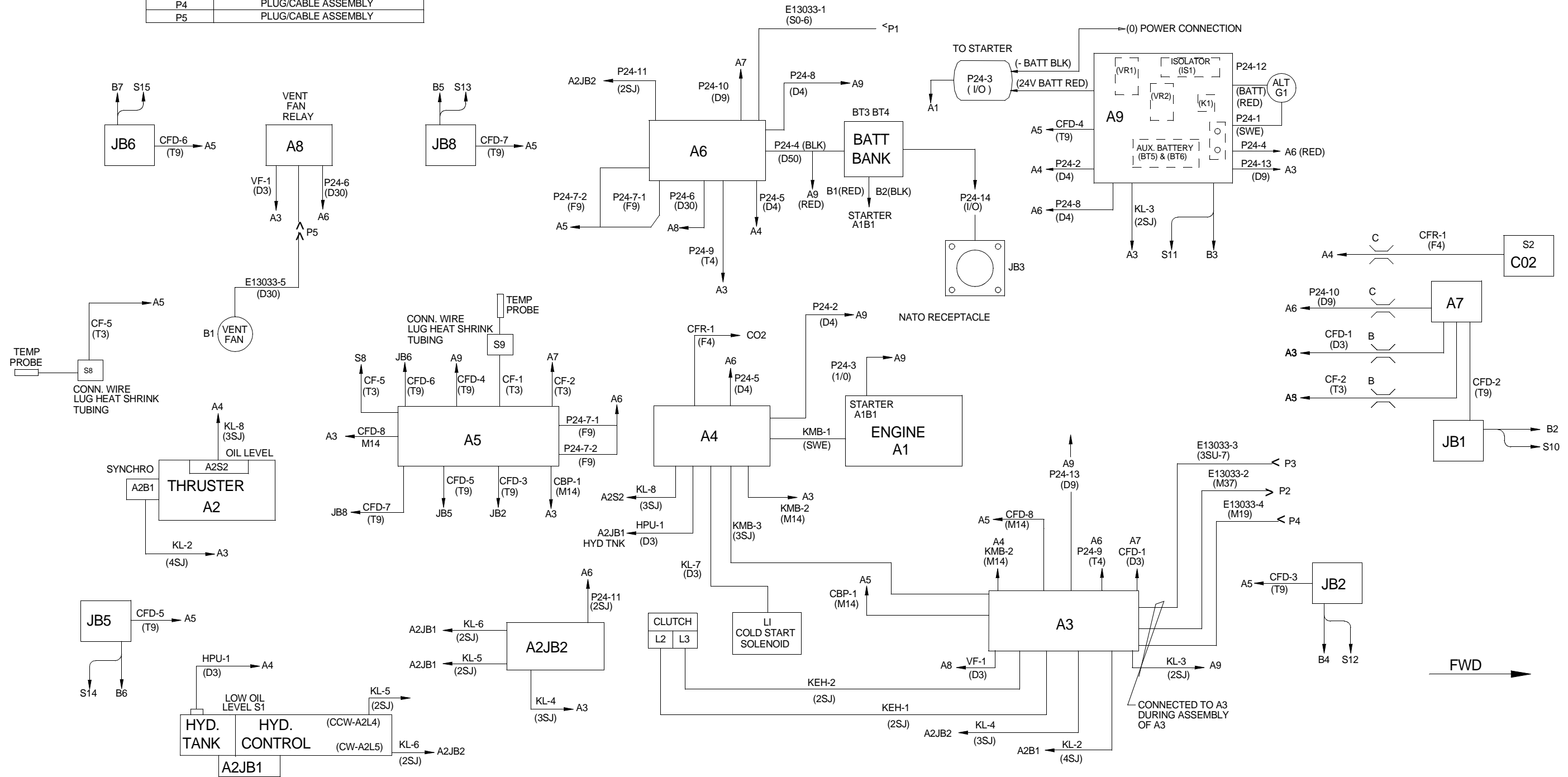

Figure 1. MCS Propulsion Module Electrical Assembly Wiring Diagram (Sheet 2).

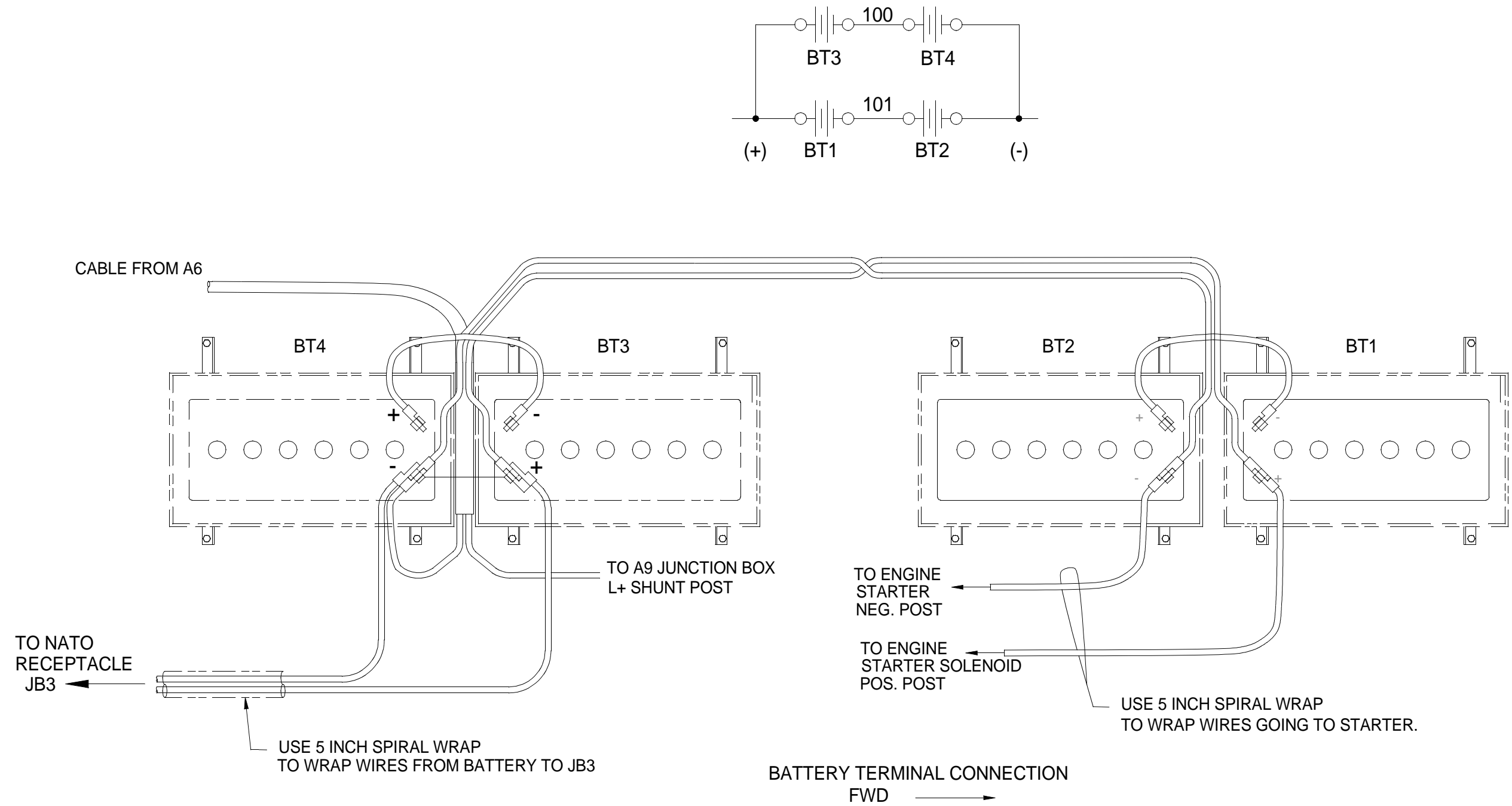

Figure 1. MCS Propulsion Module Electrical Assembly Wiring Diagram (Sheet 3).

PROPULSION MODULE
UNIT 1 IF LOCATED STBD
UNIT 2 IF LOCATED PORT

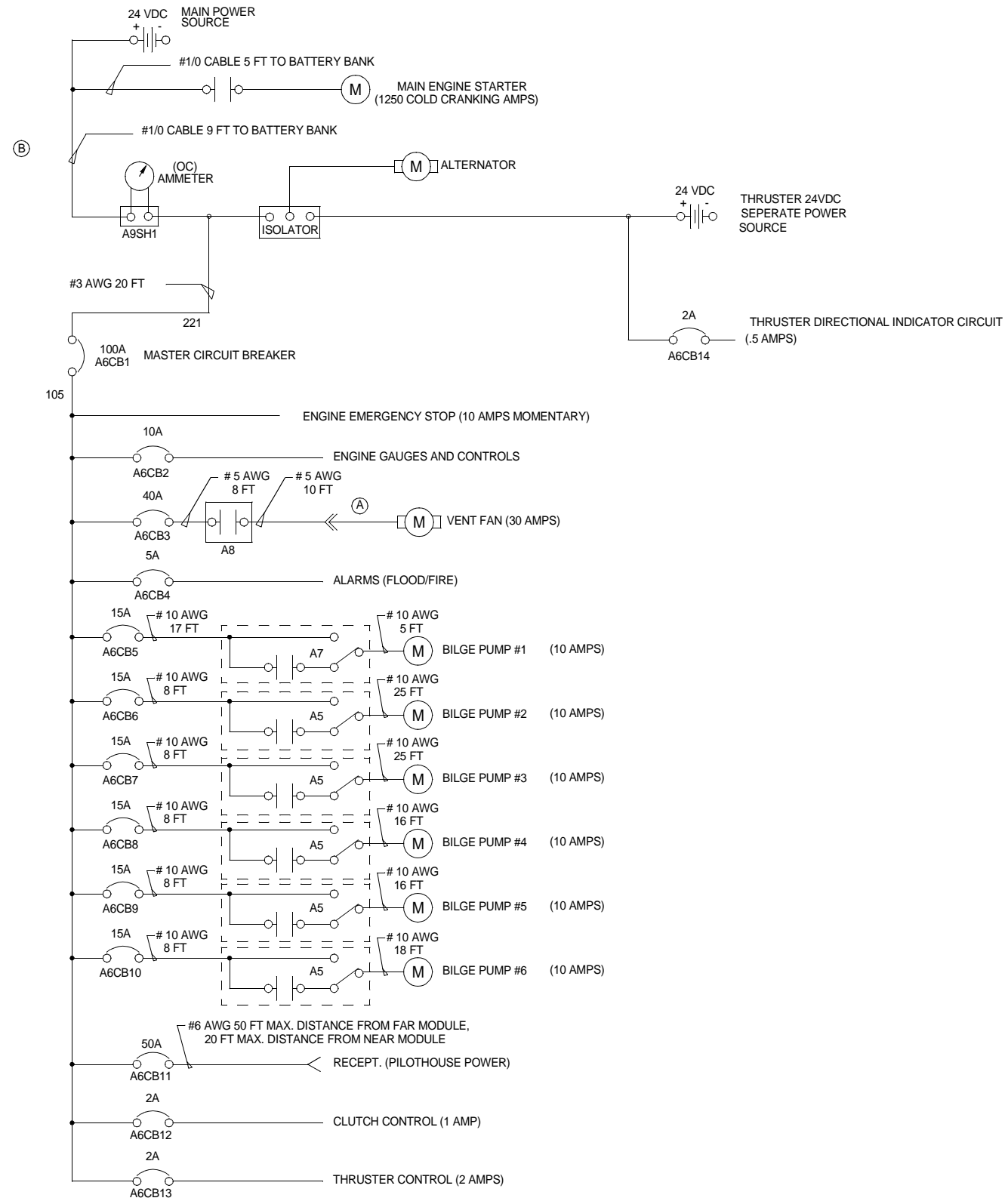

Figure 2. MCS Propulsion Module One Line Diagram.

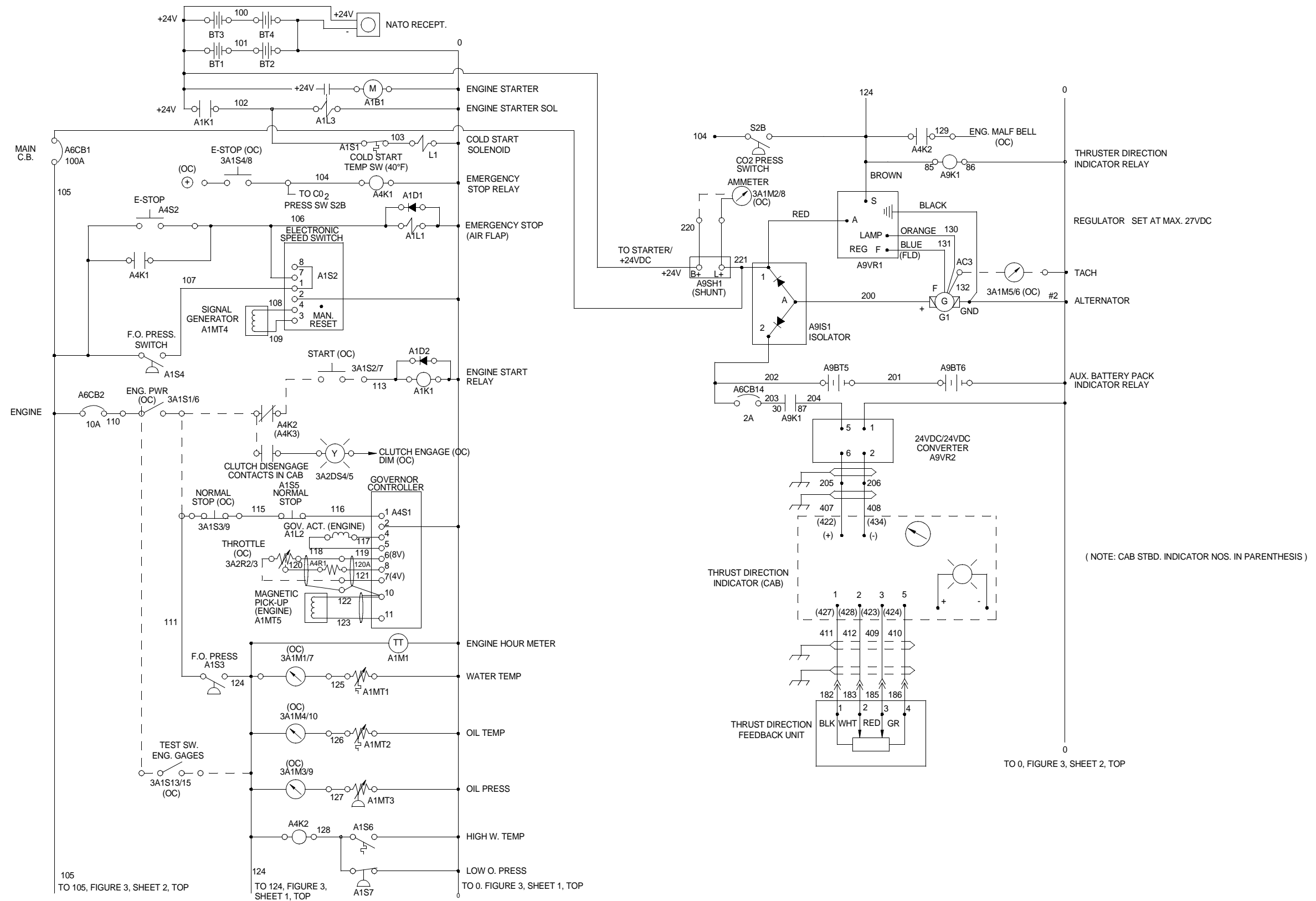

Figure 3. MCS Propulsion Module Schematic (Sheet 1).

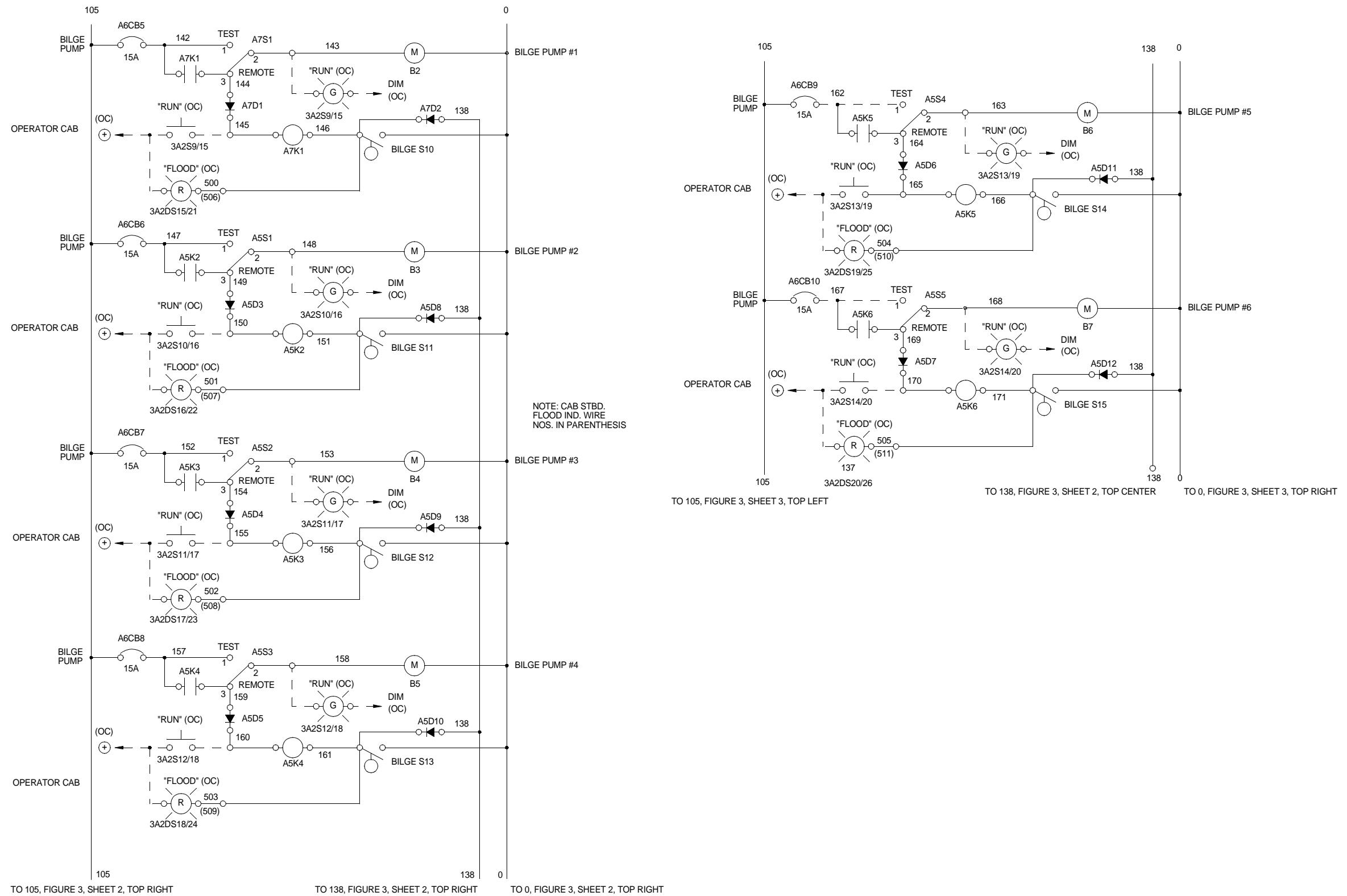

Figure 3. MCS Propulsion Module Schematic (Sheet 2).

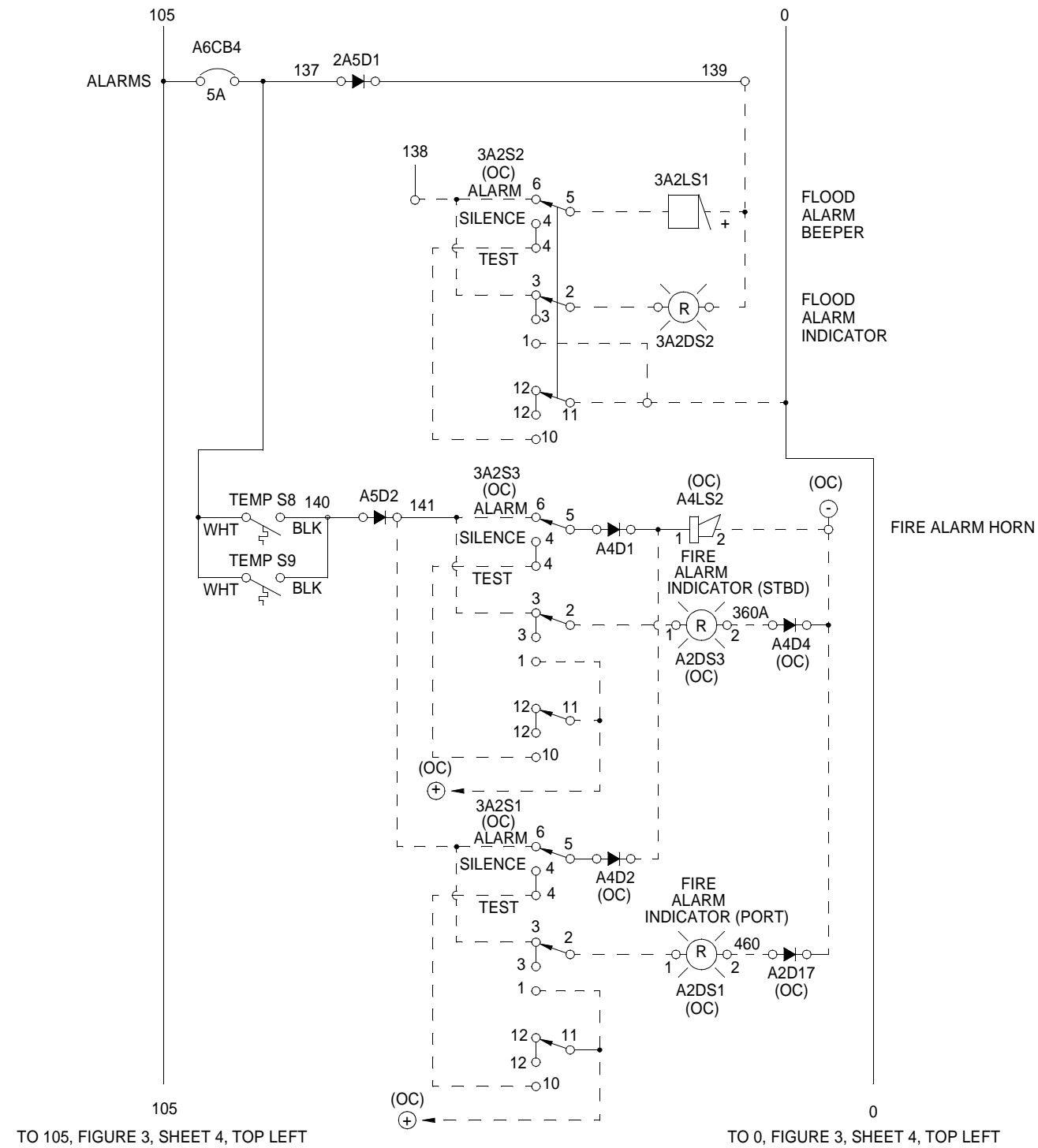
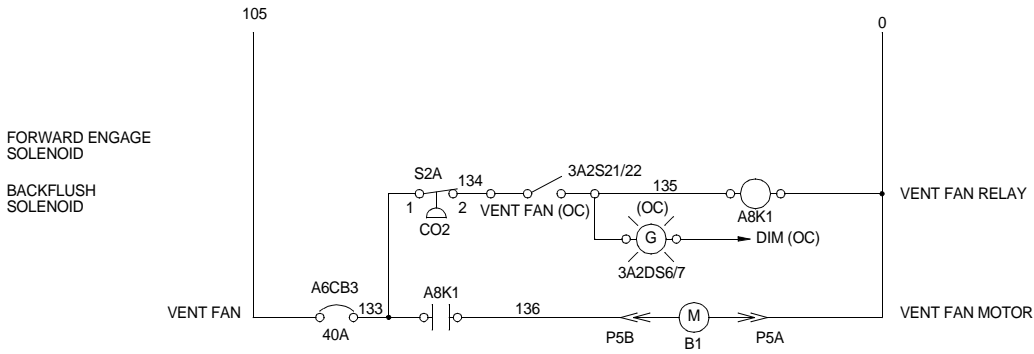
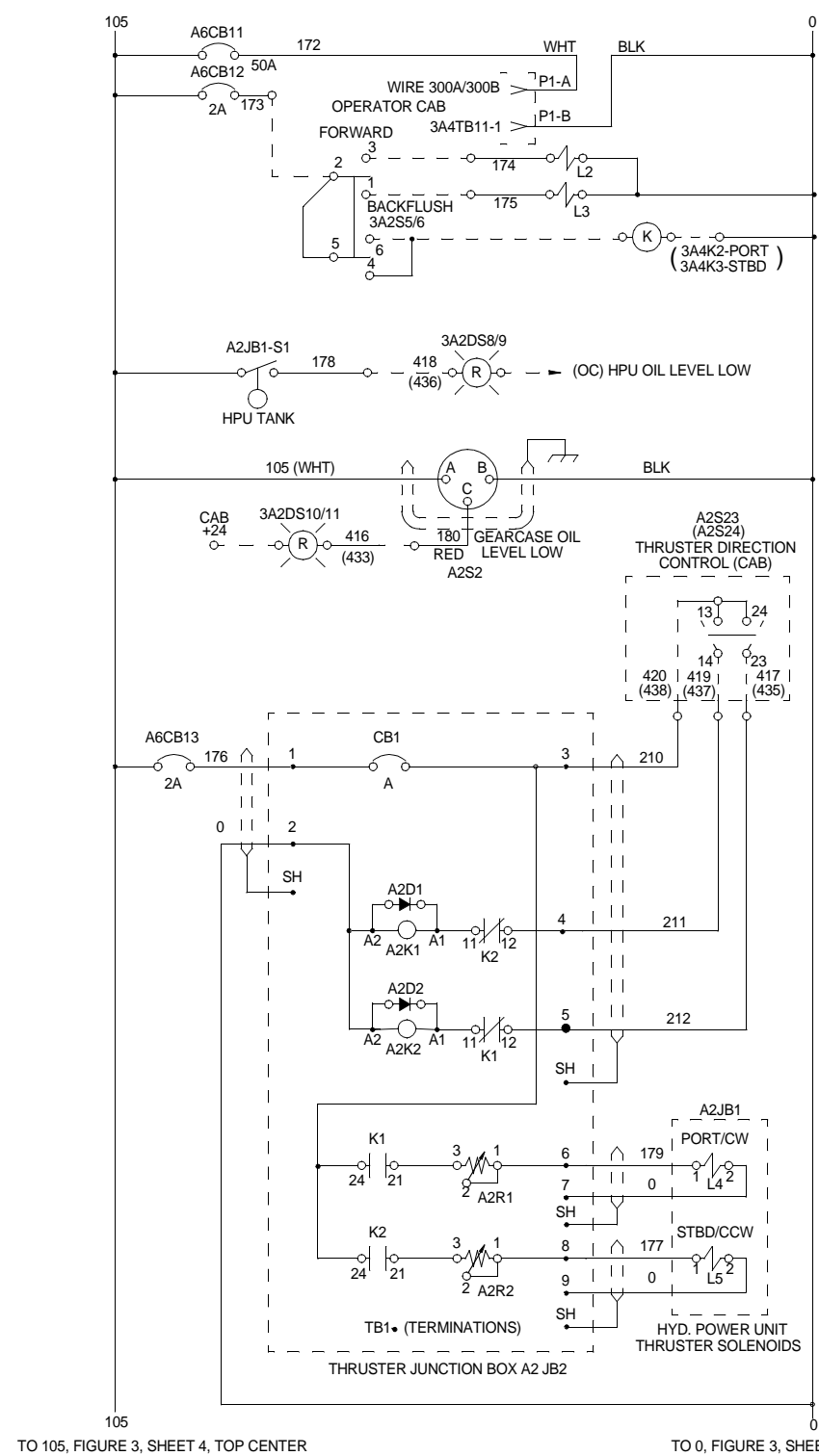

Figure 3. MCS Propulsion Module Schematic (Sheet 3).



LEGEND

ABBREVIATION	EXPLANATION
AC3	CONNECTION FOR ALTERNATOR STATOR WINDING USED FOR TACHOMETER
CO2	CARBON DIOXIDE/FIRE EXTINGUISHING SYSTEM
E-STOP	ENGINE EMERGENCY STOP/AIR SHUT-OFF
ENG PWR	ENGINE POWER
ENG MALF	ENGINE MALFUNCTION, INDICATES LOW OIL PRESSURE OR HIGH WATER (COOLANT) TEMPERATURE
FLD	ALTERNATOR FIELD
FO PRESS	FUEL OIL PRESSURE
HIGH W TEMP	HIGH ENGINE WATER (COOLANT) TEMPERATURE
LOW O PRESS	LOW ENGINE OIL PRESSURE
OC	OPERATOR CAB/ALSO DESIGNATED AS UNIT 3
TACH	TACHOMETER FOR ENGINE SPEED IN RPM

DESIGNATORS

NOTE: ALL DESIGNATORS ARE PREFIXED WITH UNIT OR ASSEMBLY NUMBERS AND FOLLOWED BY AN ASSIGNED NUMBER FOR IDENTIFICATION. SEE NOTE 4 FOR A DESCRIPTION OF UNIT DESIGNATORS.

DESIGNATOR	DEVICE
A1	DIESEL ENGINE & ELECTRICAL COMPONENTS INSTALLED ON ENGINE
A2	THRUSTER & ASSOCIATED ELECTRICAL COMPONENTS, E26929
A3	POWER MODULE JUNCTION BOX, E09683
A4	ENGINE JUNCTION BOX, E08913
A5	BILGE PUMP CONTROL PANEL, E08893
A6	POWER MODULE CIRCUIT BREAKER PANEL, E06783
A7	SINGLE BILGE PUMP CONTROL PANEL, E08903
A8	VENT FAN RELAY ENCLOSURE, E23703
A9	THRUSTER DIRECTION / AUX. BATT. JUNCTION BOX ASS'Y
B	MOTOR, STARTER or SYNCHRO
BT	BATTERY
CB	CIRCUIT BREAKER
D	DIODE, SEMICONDUCTOR
DS	INDICATING LAMP
K	RELAY
L	SOLENOID
LS	AUDIBLE DEVICE, BEEPER etc.
M	METER, GAGE or PICK-UP
MT	TRANSDUCER FOR METER/GAGE
S	SWITCH or GOVERNOR
VR	REGULATOR
SH	SHUNT
IS	ISOLATOR

EXAMPLES: 1) A1M1, THIS IS METER NUMBER 1 (ENGINE HOUR METER) INSTALLED ON DIESEL ENGINE (A1)
 2) S3, THIS IS SWITCH NUMBER 3 (NEUTRAL LIMIT SWITCH) IN POWER MODULE. THIS SWITCH IS THE ONLY ELECTRICAL COMPONENT INSTALLED ON THE POWER TAKE OFF CLUTCH ENGAGEMENT CYLINDER.
 3) 3A2DS13/19, THIS IS INDICATING LAMP (DS) NUMBER 13 FOR PORT AND NUMBER 19 FOR STBD LOCATED IN ASSEMBLY A2 IN THE OPERATOR CAB (UNIT 3). SEE OPERATOR CAB SCHEMATIC E26546 AND ASSEMBLY E02873 FOR DESCRIPTION OF THE A2 ASSEMBLY WHICH IS THE LOWER CONTROL PANEL ASSEMBLY "A2" DRAWING E06773.

- NOTES:
- CONDUCTORS GOING TO OPERATOR CAB ARE SHOWN AS DASHED. DEVICES IN OPERATOR CAB HAVE DESIGNATIONS THAT START WITH "3". LAST DIGIT OF OPERATOR CAB DEVICES IF SEPARATED FOR PORT/STBD ARE SHOWN WITH A SLASH BETWEEN THE PORT AND STBD DEVICE NUMBERS.
 - THIS SCHEMATIC DOES NOT SHOW ALL TERMINAL OR CONNECTOR PIN NUMBERS.
 - SYSTEM DESIGNATORS (ALL DESIGNATORS NOT USED ON THIS SCHEMATIC)
 UNIT 1 : STBD PROPULSION MODULE. THIS IS MODULE INSTALLED IN STBD LOCATION.
 UNIT 2 : PORT PROPULSION MODULE. THIS IS MODULE INSTALLED IN PORT LOCATION.
 UNIT 3 : OPERATOR CAB
 UNIT 4 : MAIN MAST
 UNIT 5 : STUB MAST
 - GOVERNOR A4S1 SETTINGS AS FOLLOWS:
 SWITCH S1=OFF
 SWITCH S2=ON
 GAIN = 40% OR 50% POSITION
 DROOP = FULL CCW
 I = 30% POSITION
 IDLE SPEED 800 RPM MINIMUM

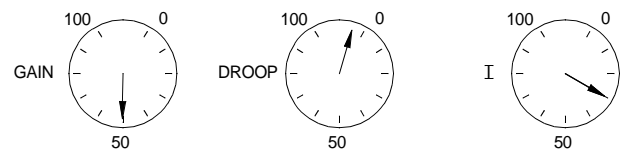

TO 105, FIGURE 3, SHEET 4, TOP CENTER

TO 0, FIGURE 3, SHEET 4, TOP RIGHT

Figure 3. MCS Propulsion Module Schematic (Sheet 4).

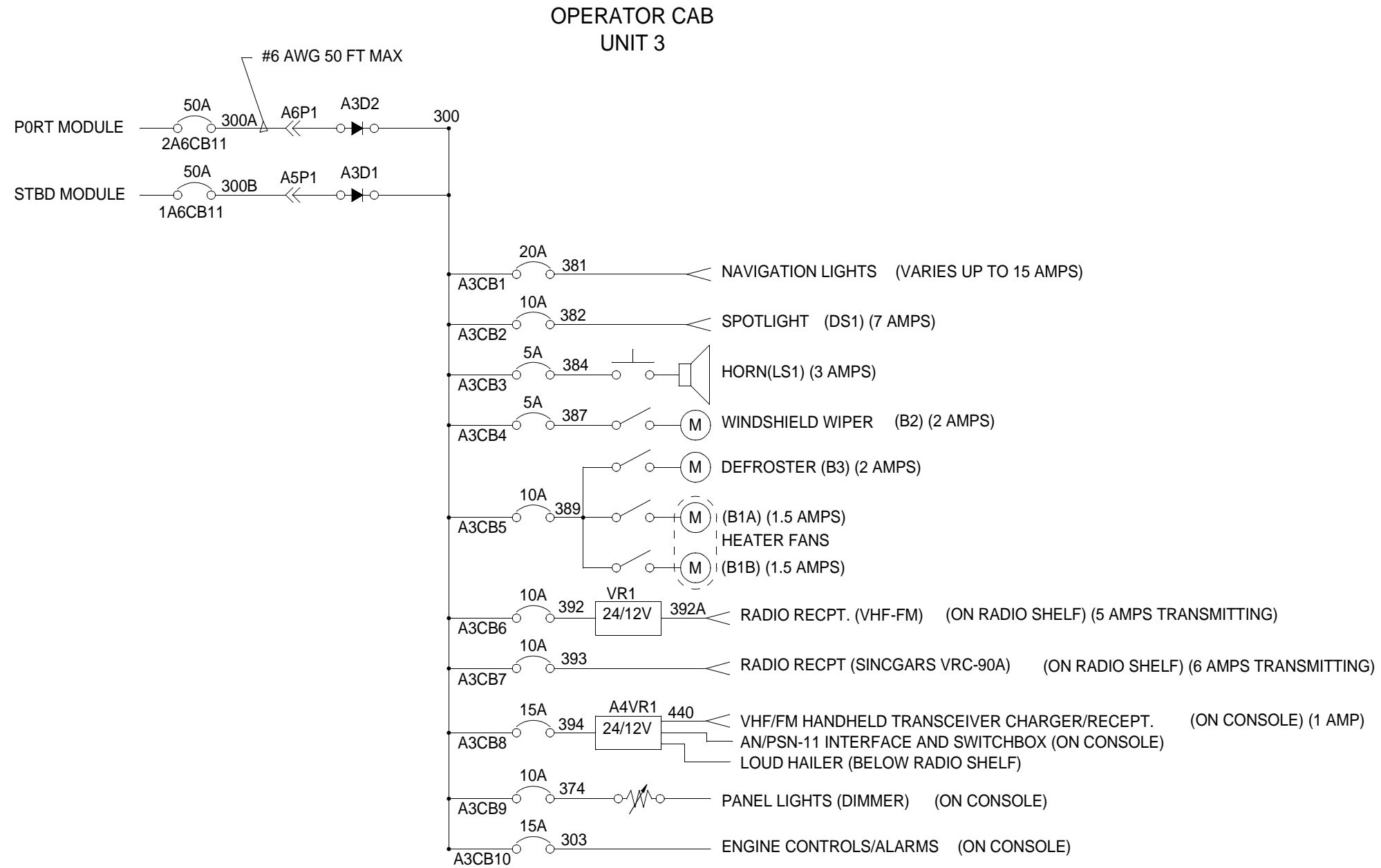

Figure 4. MCS Operator Cab One Line Diagram.

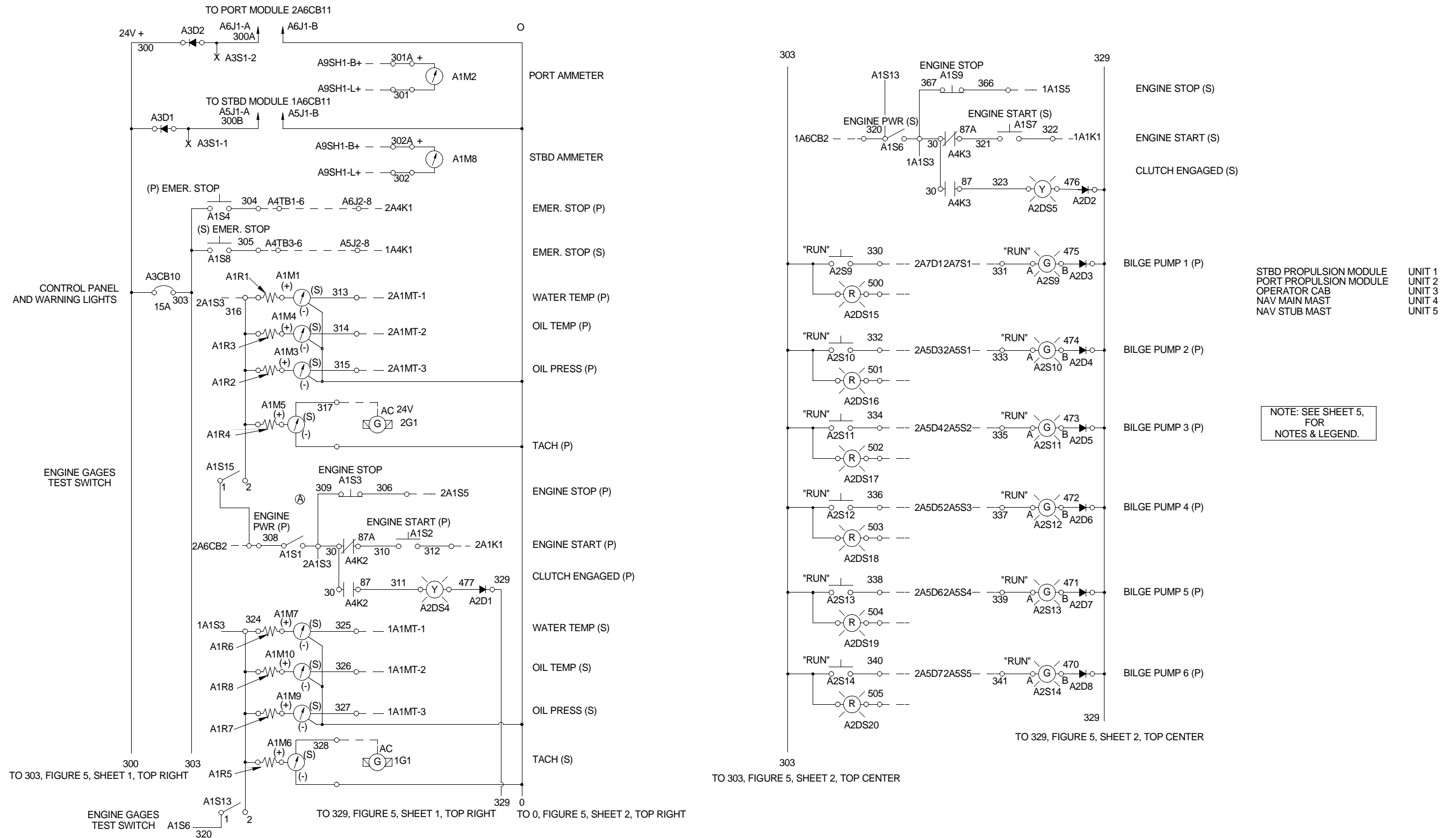

Figure 5. MCS Operator Cab Schematic (Sheet 1).

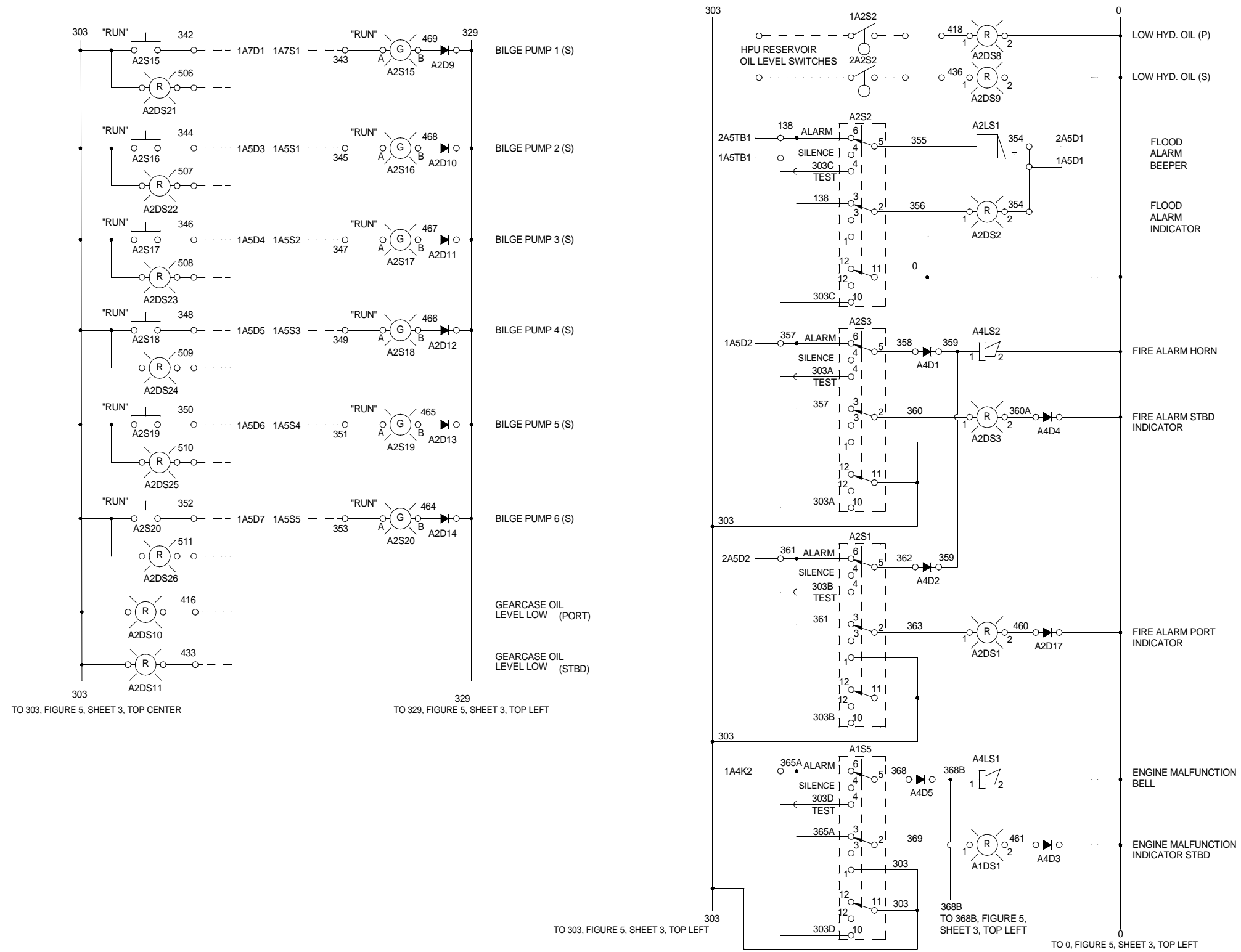

Figure 5. MCS Operator Cab Schematic (Sheet 2).

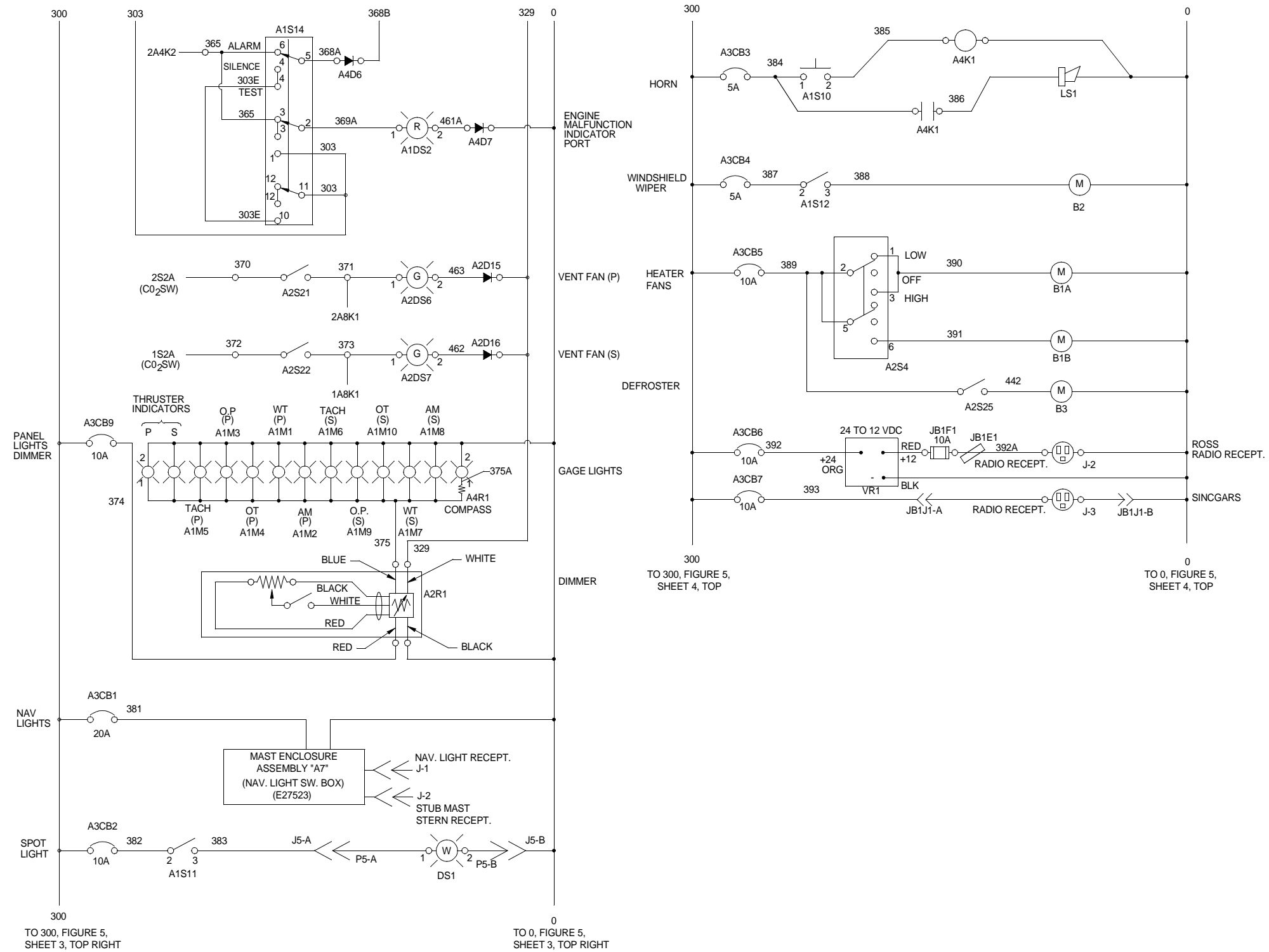
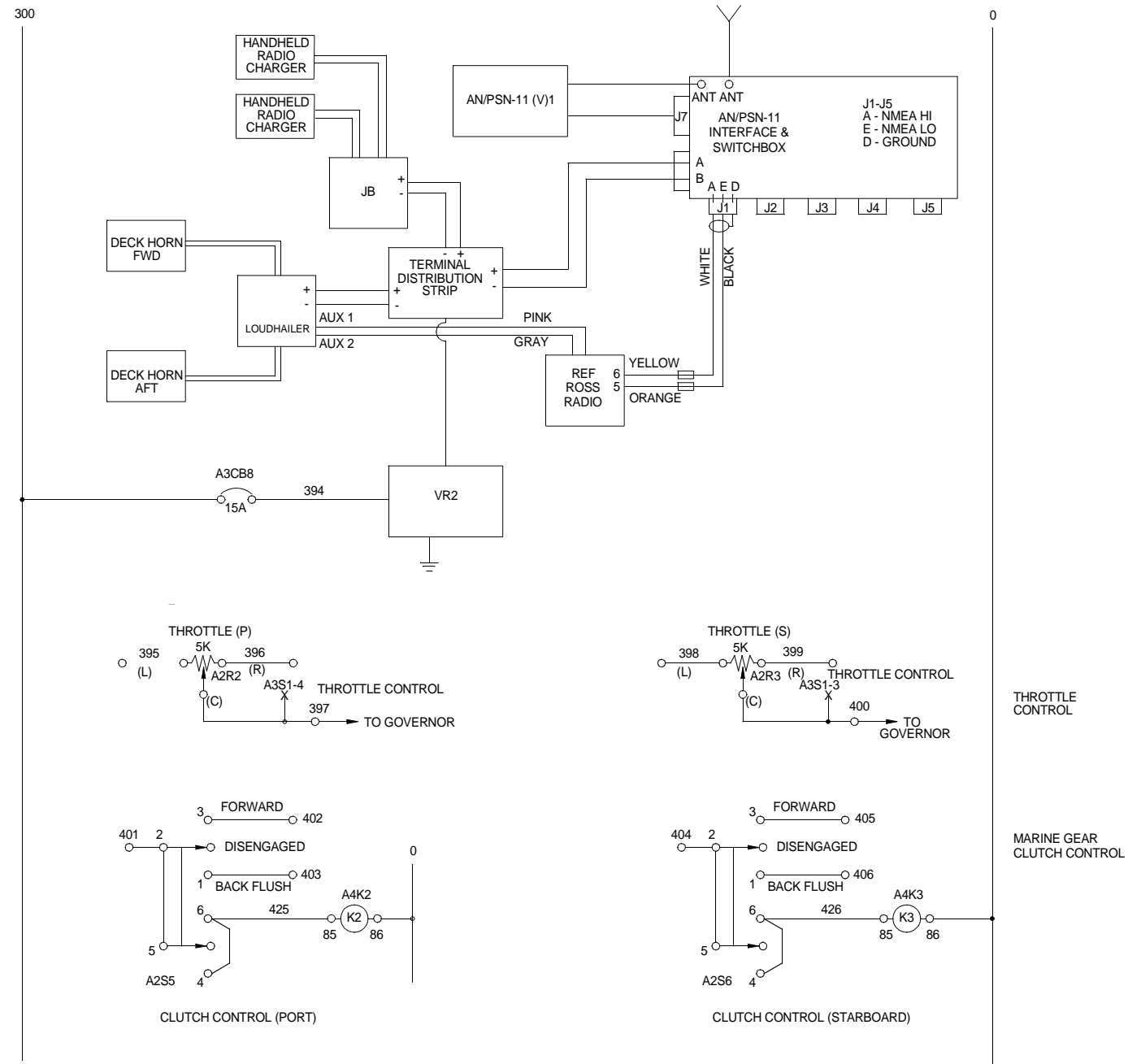

Figure 5. MCS Operator Cab Schematic (Sheet 3).



TO 300, FIGURE 5,
SHEET 5, TOP

Figure 5. MCS Operator Cab Schematic (Sheet 4).

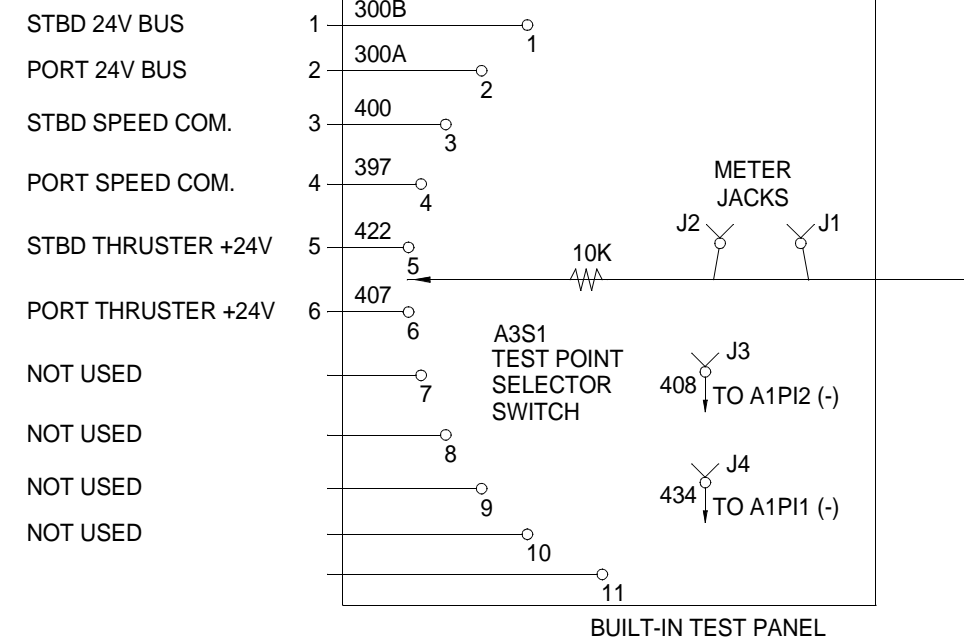
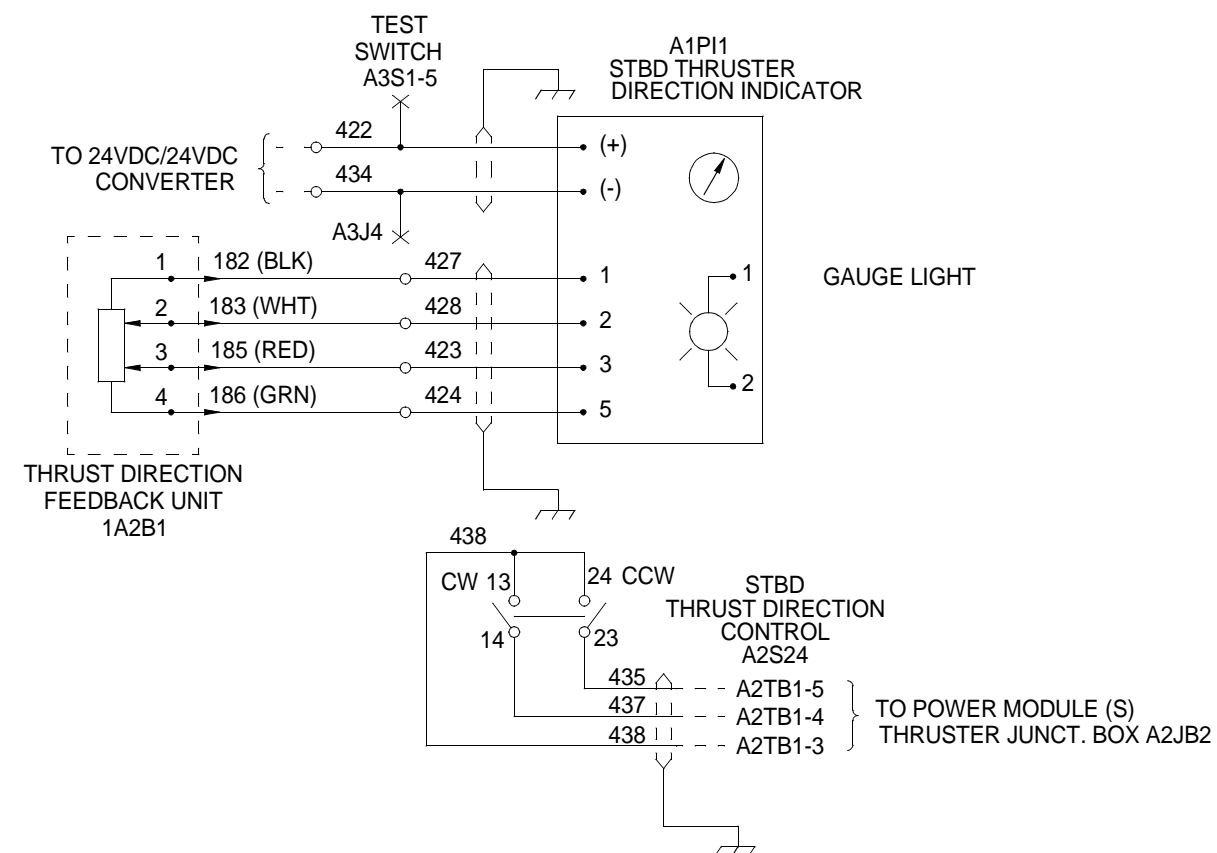
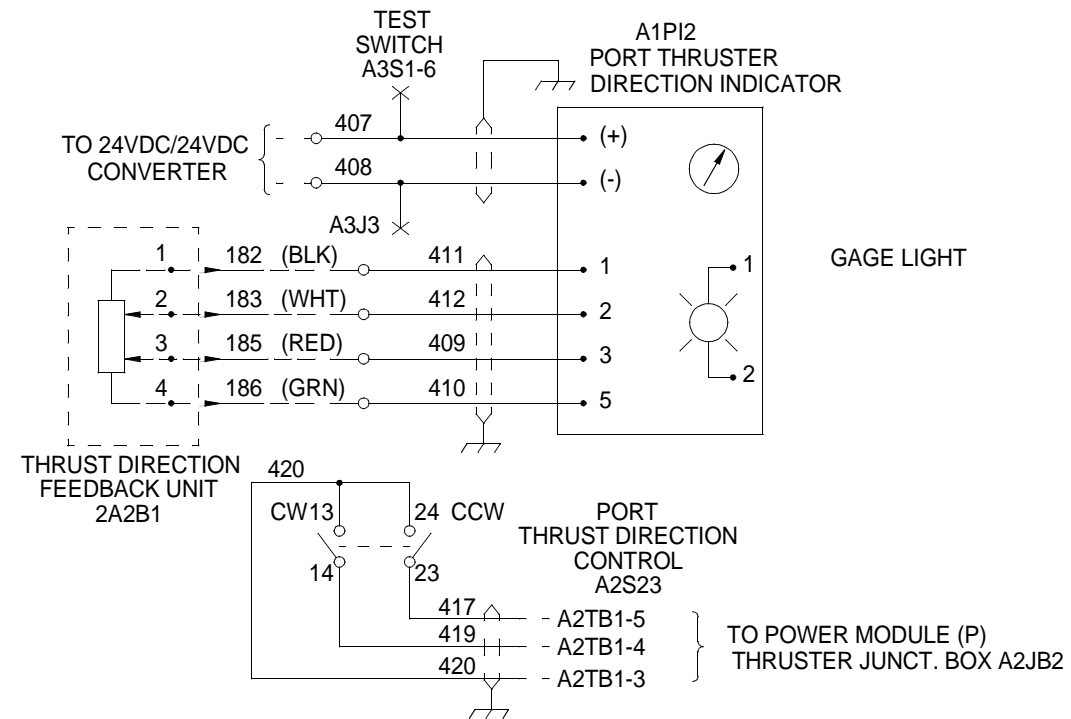

Figure 5. MCS Operator Cab Schematic (Sheet 5).

DESIGNATORS

NOTE: ALL DESIGNATORS ARE PREFIXED WITH UNIT OR ASSEMBLY NUMBERS AND FOLLOWED BY AN ASSIGNED NUMBER FOR IDENTIFICATION.

DESIGNATOR	DEVICE
A1	MIDDLE CONTROL PANEL ASSEMBLY, E06763
A2	LOWER CONTROL PANEL ASSEMBLY, E06773
A3	OPERATOR CAB CIRCUIT BREAKER PANEL, E06793
A4	TERMINAL STRIP ASSEMBLY, E08683
A5	STBD RECEPTACLE ASSEMBLY, E08873
A6	PORT RECEPTACLE ASSEMBLY, E08883
A7	MAST ENCLOSURE ASSEMBLY, E27523
B	MOTOR, STARTER or SYNCHRO
BT	BATTERY
CB	CIRCUIT BREAKER
D	DIODE, SEMICONDUCTOR
DS	INDICATING LAMP
E	EMI/RFI SUPPRESSOR
G	ALTERNATOR
JB	JUNCTION BOX
K	RELAY
LS	AUDIBLE DEVICE, BEEPER etc.
M	METER, GAGE or PICK-UP
MT	TRANSDUCER FOR METER/GAGE
PI	PANEL INDICATOR
R	RESISTOR OR POTENTIOMETER
S	SWITCH INCLUDING ILLUMINATED PUSHBUTTON SWITCHES
VR	VOLTAGE CONVERTER, 24VDC TO 12 VDC

- EXAMPLES: 1) A1M1, THIS IS METER NUMBER 1 (PORT ENGINE WATER TEMP METER) INSTALLED ON MIDDLE CONTROL PANEL ASSEMBLY "A1"
- 2) A1S6, THIS IS SWITCH NUMBER 6 (STBD ENGINE POWER SWITCH) INSTALLED ON MIDDLE CONTROL PANEL ASSEMBLY "A1"
- 3) A2S13, THIS IS SWITCH NUMBER 13 (ILLUMINATED PUSHBUTTON SWITCH FOR PORT BILGE PUMP NUMBER 5 INSTALLED ON LOWER CONTROL PANEL ASSEMBLY "A2"

NOTES:

1. CONDUCTORS SHOWN AS DASHED CONTINUE TO PROPULSION MODULES THROUGH CONNECTORS. DEVICES IN PROPULSION MODULES ARE DESIGNATED BY NUMERICAL PREFIX, TYPE DESIGNATION, AND PART NUMBER. PORT (2) OR STBD (1) MODULE DESIGNATIONS PREFIX PART DESIGNATOR.
2. THIS SCHEMATIC DOES NOT SHOW ALL TERMINALS OR CONNECTOR PIN NUMBERS.
3. TERMINAL MARKINGS ON GAGES OR OTHER DEVICES MAY DIFFER DUE TO ALTERNATE SOURCES.
4. "RUN" LIGHTS A2S9 THROUGH A2S20 (SHEET 1) ARE PART OF ILLUMINATED PUSHBUTTON SWITCHES A2S9 THROUGH A2S20. FOR SCHEMATIC PURPOSES THESE LIGHTS HAVE "S" DESIGNATIONS INSTEAD OF "DS" DESIGNATION FOR OTHER LIGHTS IN THE SYSTEM.

LEGEND

ABBREVIATION	EXPLANATION
AC	CONNECTION FOR ALTERNATOR STATOR WINDING USED FOR TACHOMETER
E-STOP	ENGINE EMERGENCY STOP/AIR SHUT-OFF
ENG PWR	ENGINE POWER
ENG MALF	ENGINE MALFUNCTION, INDICATES LOW OIL PRESSURE OR HIGH COOLANT TEMPERATURE
DISENGAGED	CLUTCH IN NEUTRAL POSITION
(P)	PORT
RECEPT	RECEPTACLE, CONNECTOR
(S)	STBD
SINGGARS	GOVERNMENT FURNISHED RADIO, SINGLE CHANNEL GROUND & AIRBORNE RADIO SYSTEM
SW	SWITCH
TACH	TACHOMETER FOR ENGINE SPEED IN RPM
TEMP	TEMPERATURE
AM	AMMETER

Figure 5. MCS Operator Cab Schematic (Sheet 6).

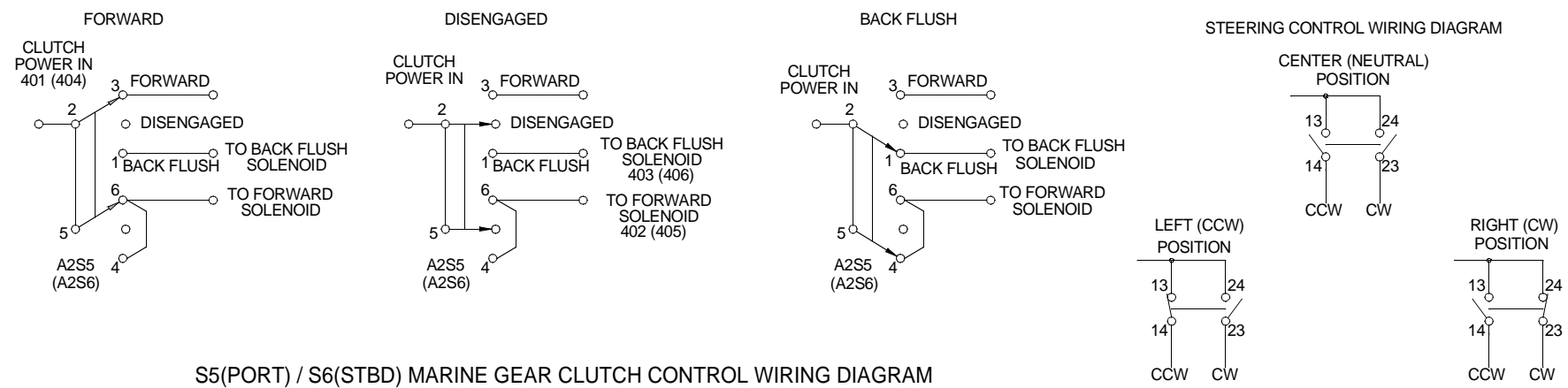
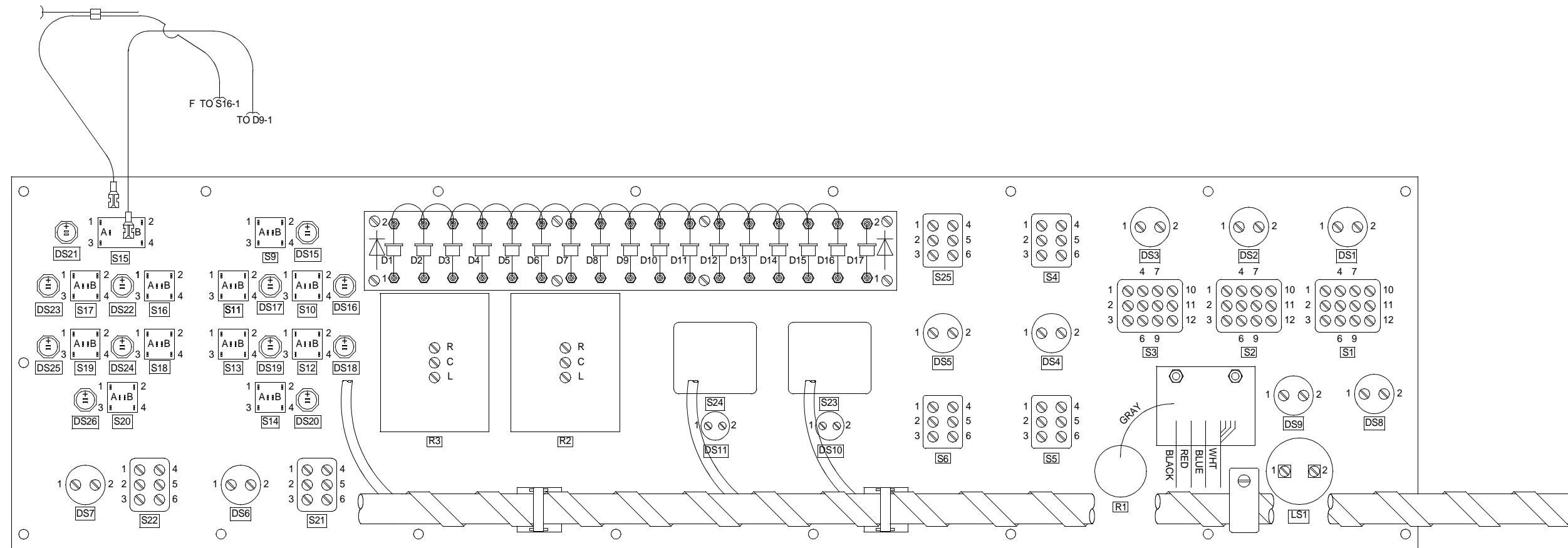

S5(PORT) / S6(STBD) MARINE GEAR CLUTCH CONTROL WIRING DIAGRAM

Figure 6. MCS Operator Cab Lower Control Panel Wiring.

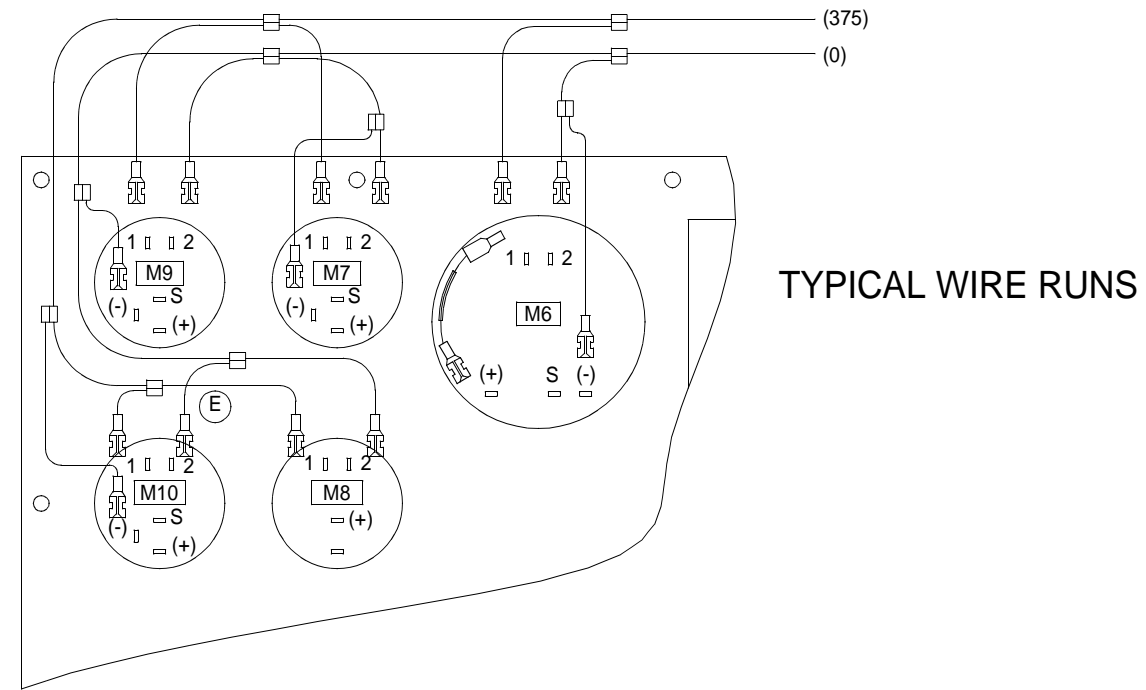

BACK SIDE OF PANEL

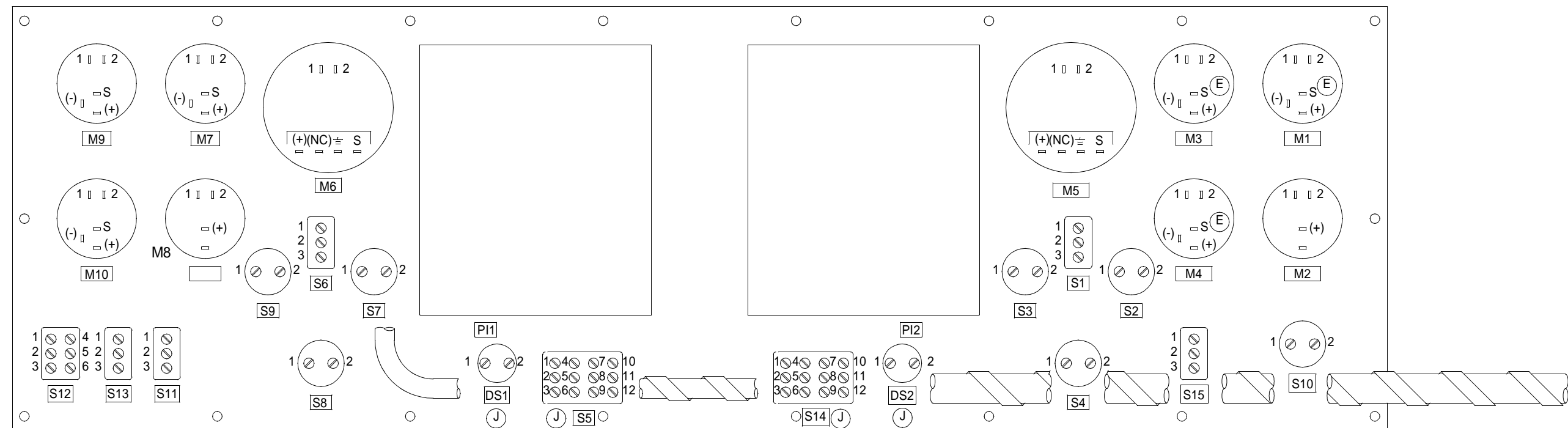

Figure 7. MCS Operator Cab Middle Control Panel Wiring.

These are the instructions for sending an electronic 2028.

The following format must be used if submitting an electronic 2028. The subject line must be exactly the same and all fields must be included; however, only the following fields are mandatory: 1, 3, 4, 5, 6, 7, 8, 9, 10, 13, 15, 16, 17 and 27.

From: "Whomever" whomever@avma27.army.mil
To: whomever@avma27.army.mil
To: TACOM-TECH-PUBS@ria.army.mil

Subject:DA Form 2028

1. **From:** Joe Smith
2. **Unit:** home
3. **Address:** 4300 Park
4. **City:** Hometown
5. **St:** MO
6. **Zip:** 77777
7. **Date Sent:** 19-OCT-93
8. **Pub no:** 55-1915-200-10
9. **Pub Title:** TM
10. **Publication Date:** 11-APR-88
11. **Change Number:** 12
12. **Submitter Rank:** MSG
13. **Submitter Fname:** Joe
14. **Submitter Mname:** T
15. **Submitter Lname:** Smith
16. **Submitter Phone:** 123-123-1234
17. **Problem:** 1
18. **Page:** 1
19. **Paragraph:** 3
20. **Line:** 4
21. **NSN:** 5
22. **Reference:** 6
23. **Figure:** 7
24. **Table:** 8
25. **Item:** 9
26. **Total:** 123
27. **Text:**

This is the text for the problem below line 27.

RECOMMENDED CHANGES TO PUBLICATIONS AND BLANK FORMS For use of this form, see AR 25-30; the proponent agency is OAASA						Use Part II (<i>reverse</i>) for Repair Parts and Special Tool Lists (RPSTL) and Supply Catalogs/Supply Manuals (SC/SM).	DATE
TO: (<i>Forward to proponent of publication or form</i>) (<i>Include ZIP Code</i>)						FROM: (<i>Activity and location</i>) (<i>Include ZIP Code</i>)	
PART I - ALL PUBLICATIONS (EXCEPT RPSTL AND SC/SM) AND BLANK FORMS							
PUBLICATION/FORM NUMBER						DATE	TITLE
ITEM	PAGE	PARA-GRAPH	LINE	FIGURE NO.	TABLE	RECOMMENDED CHANGES AND REASON	
<i>* Reference to line numbers within the paragraph or subparagraph.</i>							
TYPED NAME, GRADE OR TITLE					TELEPHONE EXCHANGE/AUTOVON, PLUS EXTENSION		SIGNATURE

TO: <i>(Forward direct to addressee listed in publication)</i>			FROM: <i>(Activity and location) (Include ZIP Code)</i>				DATE	
PART II - REPAIR PARTS AND SPECIAL TOOL LISTS AND SUPPLY CATALOGS/SUPPLY MANUALS								
PUBLICATION NUMBER				DATE		TITLE		
PAGE NO.	COLM NO.	LINE NO.	NATIONAL STOCK NUMBER	REFERENCE NO.	FIGURE NO.	ITEM NO.	TOTAL NO. OF MAJOR ITEMS SUPPORTED	RECOMMENDED ACTION
PART III - REMARKS <i>(Any general remarks or recommendations, or suggestions for improvement of publications and blank forms. Additional blank sheets may be used if more space is needed.)</i>								
TYPED NAME, GRADE OR TITLE			TELEPHONE EXCHANGE/AUTOVON, PLUS EXTENSION			SIGNATURE		

By Order of the Secretary of the Army:

PETER J. SCHOOMAKER
General, United States Army
Chief of Staff

Official:



JOEL B. HUDSON
Administrative Assistant to the
Secretary of the Army
0231376

To be distributed in accordance with the initial distribution number (IDN) 256760 requirements for
TM 55-1945-205-24-1-2.

The Metric System and Equivalents

Linear Measure

1 centimeter = 10 millimeters = .39 inch
 1 decimeter = 10 centimeters = 3.94 inches
 1 meter = 10 decimeters = 39.37 inches
 1 dekameter = 10 meters = 32.8 feet
 1 hectometer = 10 dekameters = 328.08 feet
 1 kilometer = 10 hectometers = 3,280.8 feet

Weights

1 centigram = 10 milligrams = .15 grain
 1 decigram = 10 centigrams = 1.54 grains
 1 gram = 10 decigram = .035 ounce
 1 dekagram = 10 grams = .35 ounce
 1 hectogram = 10 dekagrams = 3.52 ounces
 1 kilogram = 10 hectograms = 2.2 pounds
 1 quintal = 100 kilograms = 220.46 pounds
 1 metric ton = 10 quintals = 1.1 short tons

Liquid Measure

1 centiliter = 10 milliliters = .34 fl. ounce
 1 deciliter = 10 centiliters = 3.38 fl. ounces
 1 liter = 10 deciliters = 33.81 fl. ounces
 1 dekaliter = 10 liters = 2.64 gallons
 1 hectoliter = 10 dekaliters = 26.42 gallons
 1 kiloliter = 10 hectoliters = 264.18 gallons

Square Measure

1 sq. centimeter = 100 sq. millimeters = .155 sq. inch
 1 sq. decimeter = 100 sq. centimeters = 15.5 sq. inches
 1 sq. meter (centare) = 100 sq. decimeters = 10.76 sq. feet
 1 sq. dekameter (are) = 100 sq. meters = 1,076.4 sq. feet
 1 sq. hectometer (hectare) = 100 sq. dekameters = 2.47 acres
 1 sq. kilometer = 100 sq. hectometers = .386 sq. mile

Cubic Measure

1 cu. centimeter = 1000 cu. millimeters = .06 cu. inch
 1 cu. decimeter = 1000 cu. centimeters = 61.02 cu. inches
 1 cu. meter = 1000 cu. decimeters = 35.31 cu. feet

Approximate Conversion Factors

<i>To change</i>	<i>To</i>	<i>Multiply by</i>	<i>To change</i>	<i>To</i>	<i>Multiply by</i>
inches	centimeters	2.540	ounce-inches	newton-meters	.007062
feet	meters	.305	centimeters	inches	.394
yards	meters	.914	meters	feet	3.280
miles	kilometers	1.609	meters	yards	1.094
square inches	square centimeters	6.451	kilometers	miles	.621
square feet	square meters	.093	square centimeters	square inches	.155
square yards	square meters	.836	square meters	square feet	10.764
square miles	square kilometers	2.590	square meters	square yards	1.196
acres	square hectometers	.405	square kilometers	square miles	.386
cubic feet	cubic meters	.028	square hectometers	acres	2.471
cubic yards	cubic meters	.765	cubic meters	cubic feet	35.315
fluid ounces	milliliters	29.573	cubic meters	cubic yards	1.308
pints	liters	.473	milliliters	fluid ounces	.034
quarts	liters	.946	liters	pints	2.113
gallons	liters	3.785	liters	quarts	1.057
ounces	grams	28.349	liters	gallons	.264
pounds	kilograms	.454	grams	ounces	.035
short tons	metric tons	.907	kilograms	pounds	2.205
pound-feet	newton-meters	1.356	kilograms	short tons	1.102
pound-inches	newton-meters	.11296	metric tons		

Temperature (Exact)

°F	Fahrenheit	5/9 (after	Celsius	°C
	temperature	subtracting 32)	temperature	

